

STRAIGHT SQUARE FLANGE JACK

R143.254.000

CLAMP TYPE - CABLE 2.6/50+75

Series : TNC

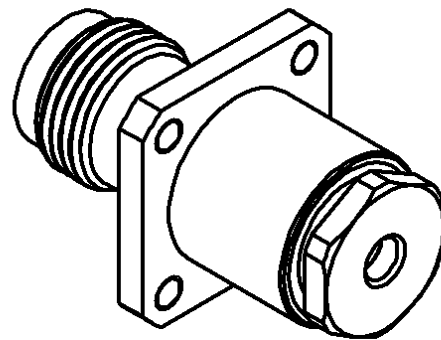
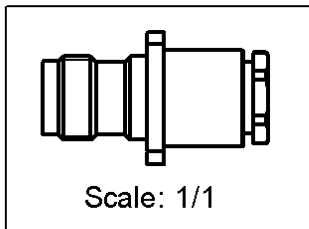
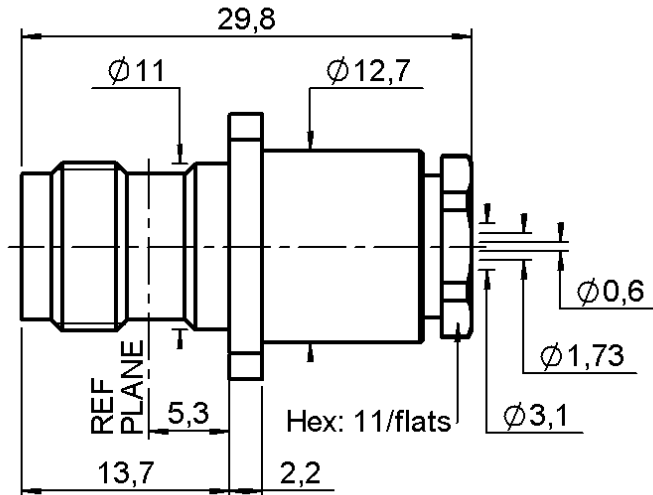
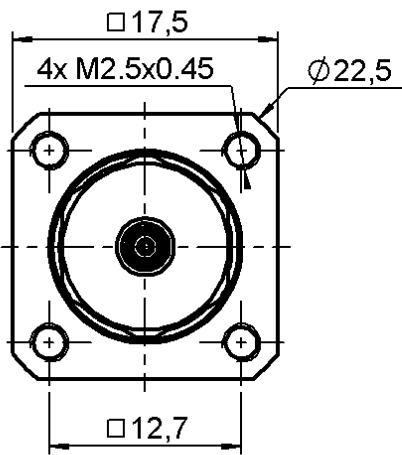

PANEL CUT OUT

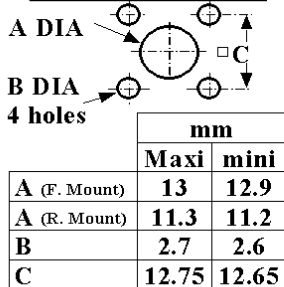

All dimensions are in mm.



COMPONENTS	MATERIALS	PLATINGS (µm)
BODY	BRASS	NICKEL 2
CENTER CONTACT	BERYLLIUM COPPER	GOLD 0.5 OVER NICKEL 2
OUTER CONTACT	-	-
INSULATOR	PTFE	-
GASKET	SILICONE RUBBER	-
OTHERS PARTS	BRASS	NICKEL 2
-	-	-
-	-	-

Issue : 0225 K

In the effort to improve our products, we reserve the right to make changes judged to be necessary.



STRAIGHT SQUARE FLANGE JACK

R143.254.000

CLAMP TYPE - CABLE 2.6/50+75

Series : TNC

PACKAGING

Standard	Unit	Other
1	-	Contact us

SPECIFICATION

ELECTRICAL CHARACTERISTICS

Impedance		50 Ω
Frequency		0-11 GHz
VSWR	1.30 +	0.000 x F(GHz) Maxi
Insertion loss		0.06 √F(GHz) dB Maxi
RF leakage	- (57 - F(GHz)) dB Maxi
Voltage rating		335 Veff Maxi
Dielectric withstanding voltage		1000 Veff mini
Insulation resistance		5000 MΩ mini

CABLE ASSEMBLY

Stripping	a	b	c	d	e	f
mm	4.00	2.00	9.00	0.00	5.00	0.00

Assembly instruction : **Clamp 01**

Recommended cable(s)
 KX 22A
 RG 188
 RG 179
 RG 187
 RG 316

Cable retention
 - pull off **110** N mini
 - torque **NA** N.cm

MECHANICAL CHARACTERISTICS

Center contact retention		
Axial force – Mating end	27	N mini
Axial force – Opposite end	27	N mini
Torque	NA	N.cm mini

TOOLING

Part Number	Description	Hexagon
.	.	.

Recommended torque		
Mating	NA	N.cm
Panel nut	NA	N.cm
Clamp nut	450	N.cm
A/F clamp nut	11.000	mm

OTHERS CHARACTERISTICS

Mating life	500	Cycles mini
Weight	21.698	g

ENVIRONMENTAL

Operating temperature	-65/+165	° C
Hermetic seal	NA	Atm.cm3/s
Panel leakage	NA	

Issue : 0225 K

In the effort to improve our products, we reserve the right to make changes judged to be necessary.

