

MAX20463A Evaluation Kit

Evaluates: MAX20463A

General Description

The MAX20463A evaluation kit (EV kit) demonstrates the MAX20463A; a small, integrated USB Type-C™ solution for automotive radio, navigation, connectivity, and USB head units and infotainment applications. The device provides a one-chip solution to convert an existing downstream-facing port from supporting the USB-A connector to supporting the USB Type-C connector.

The device features an integrated USB Type-C interface to control the new configuration channel (CC) pins found in the USB Type-C connector. It supports the downstream-facing port (DFP) role and supports V_{BUS} current limits including 1.5A and 3.0A. The MAX20463A can coexist with BC1.2 and Apple charging technologies, as these are controlled by the host emulator in the upstream module.

An integrated high-side power switch protects the device against faults and allows most fault conditions to be detected and handled by the upstream 5V power supply. This avoids possible contention, in which both the upstream 5V power supply and the MAX20463A detect the same fault and simultaneously try to resolve it.

The BIAS circuitry provides a solution to the transient conditions seen in automotive USB charging applications. The device is designed to stay powered on during the CC attach process even if V_{BUS} droops due to an overcurrent, or other low voltage condition, for a short period of time. The period of time that the part can stay powered on can be configured by the module design engineer to provide the time required for the upstream 5V power supply to detect and handle the fault. The device stay-on time is determined by the amount of capacitance on BIAS, which must be at least 22 μ F, but can be increased above this value. The device and its solution circuit are designed to conform to the USB-IF specification for short-to-ground response.

Ordering Information appears at end of data sheet.

MAX20463A is an automotive USB protector that integrates USB shield short-to-battery protection. A short circuit from the USB shield to the car battery can occur when a customer's portable device cable is connected to the vehicle Type-C receptacle, and the far end of this cable falls into the 12V cigarette lighter (accessory port) contacting the 12V center terminal. This situation can result in a damaging amount of current flow through the USB cable, and can cause cable combustion if the cigarette-lighter fuse response time is insufficient. MAX20463A is designed to sense this condition (shield shorted to battery) with the SENSE pin and control an N-channel MOSFET with the GDRV pin to stop the flow of current.

The device and EV kit operate from a V_{BUS} voltage of 4.75V to 7V.

The EV Kit enables testing and configuration of the MAX20463A's CC current advertisement behavior. The device provides a CC_SEL pin for this purpose. Connecting the CC_SEL pin to BIAS or GND through jumper J6 selects between the two different current levels (refer to [Table 1](#)).

The EV kit is configured for 3A output operation and the included three-meter USB cable allows for demonstration of use with an upstream-voltage-compensated power supply such as MAX16984, MAX16987, MAX20037, or MAX20038.

Features and Benefits

- Configurable Charge Detection Modes: USB-C 3.0A, 1.5A
- High-Side USB Power-Protection Switch
- Proven PCB Layout
- Fully Assembled and Tested

Quick Start

The following procedure demonstrates the MAX20463A's capability and EV Kit in use with a MAX20037 EV kit.

Required Equipment

- MAX20463A EV Kit
- MAX20037 or MAX20038 EV Kit
- Included 3m USB Captive Cable
- 2Ω, 20W Resistor or Electronic Load Connected to a USB Type-C Connector (Plug)
- 12.5V, 4A DC Power Supply (PS1)
- 3.3V/1A DC Power Supply (PS2)
- Variable 9V to 18V, 4A DC Power Supply or 12V Car Battery (PS3)
- 2 Digital Voltmeters (DVM) or 1 Oscilloscope
- MINIQUSB and MAX20037 GUI
- 4x 0.1"-Header Jumper Leads
- USB Type-A to Type-B Cable

Note: In the following sections, software-related items are identified by **bolding**. Text in **bold** refers to items from the EV kit software. Text in **bold and underlined** refers to items from the Windows operating system.

Initial Setup

The EV kit is fully assembled and tested. Perform the following steps to verify board operation:

- 1) Verify that MAX20037 GUI is installed.
- 2) Verify SW1 switch is set to HVEN = 1, ENBUCK = 1, SYNC = 0, CDP/DCP = 0.
- 3) Using the jumper wires, connect the MINIQUSB to the MAX20037 EV kit as follows:
 - V_{DD} to 3V3
 - SCL to SCL
 - SDA to SDA
 - GND to GND
- 4) Connect the MINIQUSB+ to the computer.
- 5) Verify the MINIQUSB+ is recognized in the **Windows Device Manager** as **USB Serial Converter**.
- 6) Connect PS1 (turned off) between the V_{BAT} and GND test points on MAX20037.
- 7) Connect 3m USB captive cable from MAX20037 to MAX20463A.
- 8) Connect DVM 1 (or oscilloscope channel 1) between the USB_5V and GND test points of the MAX20037 EV kit (this is the output of the buck).
- 9) Connect DVM 2 (or oscilloscope channel 2) to HVBUS and GND on the MAX20463A EV kit (this is the voltage that a portable device will see).
- 10) Power on PS1 at 12.5V with a 2A current limit.
- 11) Both DVM 1 and DVM 2 should measure approximately 5V.
- 12) Establish I²C communication to the GUI.
 - a. Click **Auto Read**. The output voltage and current should begin to update periodically.
 - b. Open the MAX20037 GUI; look at the message bar at the bottom of the GUI to verify that both the MINIQUSB and the EV kit are connected.
- 13) Connect the load to the USB Type-C connector on the MAX20463A EV kit.
 - If the load is connected to HVBUS/GND rather than the Type-C connection, HVBUS will not be enabled. To enable HVBUS, set SW1 #1 -or- #3 to ON, and all other positions off.
- 14) With the voltage adjustment disabled in the GUI (**Gain** = 0; default setting), measure the voltage. The voltage at the buck output should still be approximately 5V. There will be a slight drop due to the current through the SENSE resistor, output filter, and PCB trace. The voltage at the SENSP pin should be constant, regardless of current.
- 15) Click the **+** button or type directly into the **Gain** box in the GUI to set the gain to 533.
- 16) The voltage at the buck output should increase to 6.3V, and the voltage at the end of the USB Type-C connector should now be about 5.2V.



Short-to-Battery on USB Shield.

- 17) Connect an oscilloscope, additional power supply (PS3), and inductor to the EV kit as shown below:
 The inductor, if used, should be chosen based on the expected vehicle wiring harness inductance.
 PS2 is only required if 3V3 is not provided by the MINIUSB+.

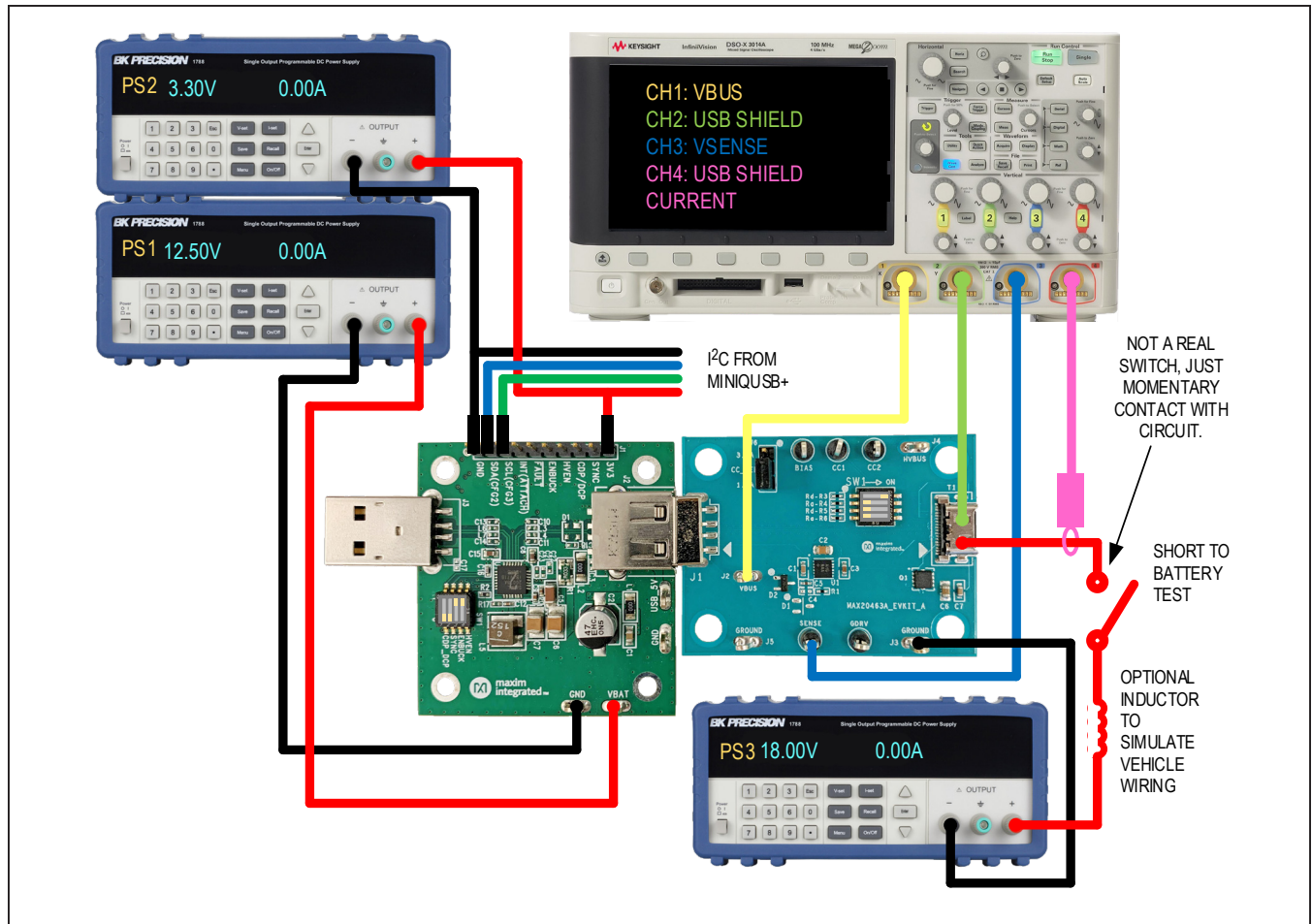

- 18) Configure the oscilloscope to trigger on rising edge of USB SHIELD (CH2).
- 19) Power supply PS3 is recommended to be set anywhere from 9.0 - 18V.
- At PS3 ≤ 16V, the series inductor is optional.
 - At PS3 > 16V, the series inductor is required.
 - A 12V lead-acid/AGM battery may also be substituted for PS3.
- 20) Manually apply brief or continuous short circuits between PS3 and USB SHIELD.
- Observe the waveforms on USB SHIELD/SENSE resulting from the short-to-battery event.
- 21) The MAX20463A will open-circuit the USB SHIELD in response to a short-to-battery event.
- USB SHIELD will remain open-circuit for as long as USB SHIELD > 150mV.
- 22) Once the short-to-battery has been removed, USB SHIELD will remain open-circuit for an additional 2.7s.
- This period allows MOSFET M1 to cool and prevent repetitive triggering of the protection circuit.
 - USB SHIELD will be reconnected to system GND after this time has elapsed.

Detailed Description

The MAX20463A EV kit comes fully assembled, tested, and installed with a MAX20463AGTCA/V+.

EV Kit Interface

The header J6 selects the default advertised current on CC1 and CC2 by controlling the CC_SEL pin. Tie this pin to ground or to BIAS to select between the two specified charge currents. [Table 1](#) lists the options for selecting the charge current.

DIP switch SW1 provides pulldown resistors (Ra and Rd) on CC1 and CC2, respectively, that are necessary for USB Type-C detection without a Type-C device attached. Switch one Rd (5.1k) to ON for Type-C detection to occur. Without one of these pulldowns present on CC1 or CC2, the 5V output will be disconnected from the USB connector. The switch positions are described in [Table 2](#).

Table 1. External Header

JUMPER POSITION	DESCRIPTION
1-2	3A current setting
2-3	1.5A current setting

Refer to the *MAX20037 EV Kit datasheet* for information on the MAX20037 EV kit interface.

PCB Layout Guidelines

A good PCB layout is critical for proper system performance. A low-impedance ground connection between the input and output capacitors is necessary (route through the ground pour on the exposed pad). Connect the exposed pad to ground. Place multiple vias in the pad to connect to all other ground layers for proper heat dissipation. Do not use separate power and analog grounds; use a single common ground, as high-frequency return currents will flow directly under the corresponding traces.

Table 2. SW1 Switch Positions

SWITCH	DESCRIPTION
1 = ON	CC1 pulled down to ground through a 5.1kΩ resistor (R3 - Rd)
2 = ON	CC1 pulled down to ground through a 1.2kΩ resistor (R4 - Ra)
3 = ON	CC2 pulled down to ground through a 5.1kΩ resistor (R5 - Rd)
4 = ON	CC2 pulled down to ground through a 1.2kΩ resistor (R6 - Ra)

Ordering Information

PART	TYPE
MAX20463AEVKIT#	EV Kit

#Denotes RoHS compliant.

MAX20463A EV Kit Bill of Materials

QTY	REFERENCE	DESCRIPTION	MANUFACTURER	MANUFACTURER PART NUMBER
5	BIAS, CC1, CC2, GDRV, SENSE	TEST POINT	KEystone	5011
2	C1, C7	CERAMIC CAPACITOR (0603) 0.1 μ F 50V 10% X7R	MURATA	GCM188R71H104K
1	C2	CERAMIC CAPACITOR (0805) 47 μ F 10V 20% X5R	MURATA	GRM21BR61A476ME15
1	C3	CERAMIC CAPACITOR (0603) 2.2 μ F 25V 10% X5R	MURATA	GRM188R61E225KA12
1	C4	DNI		
1	C5	CERAMIC CAPACITOR (0402) 0.015 μ F 50V 10% X7R	MURATA	GRM155R71H153KA12
1	C6	CERAMIC CAPACITOR (0805) 1 μ F 50V 10% X7R	MURATA	GRM21BR71H105KA12
1	D1	DNI		
1	D2	ZENER DIODE (SOT-23); VZ = 2.4V; IZ = 0.005A	DIODES INCORPORATED	BZX84C2V4-7-F
1	J1	MALE USB 2.0 TYPE A CONNECTOR	TE CONNECTIVITY	1734028-1
4	J2-J5	TEST POINT	KEystone	5024
1	J6	HEADER 3PINS	SAMTEC	TSW-103-23-G-S
1	Q1	N-CH POWER MOSFET 22A 30V	ON SEMICONDUCTOR	NVTF54C25NTAG
1	R1	RESISTOR (0402) 4.7K Ω 1% 0.10W	PANASONIC	ERJ-2RK4701
2	R3, R5	RESISTOR (0402) 5.1K Ω 5% 0.063W	VISHAY DALE	CRCW04025K10JN
2	R4, R6	RESISTOR (0402) 1.2K 1% 0.063W	VISHAY DALE	CRCW04021K20FK
1	SU1	JUMPER	SULLINS ELECTRONICS CORP.	QPC02SXGN-RC
1	SW1	QUAD SWITCH SPST 24V 0.025A	C&K COMPONENTS	TDA04H0SB1
1	T1	FEMALE USB 2.0 TYPE-C CONNECTOR 16 PINS	HIROSE	CX90M-16P
1	U1	USB TYPE-A TO TYPE-C PORT CONVERTER WITH PROTECTION	MAXIM	MAX20463AGTCAV+
1	PCB	MAX20463A revA	MAXIM	MAX20463A

MAX20463A EV Kit Schematic Diagram

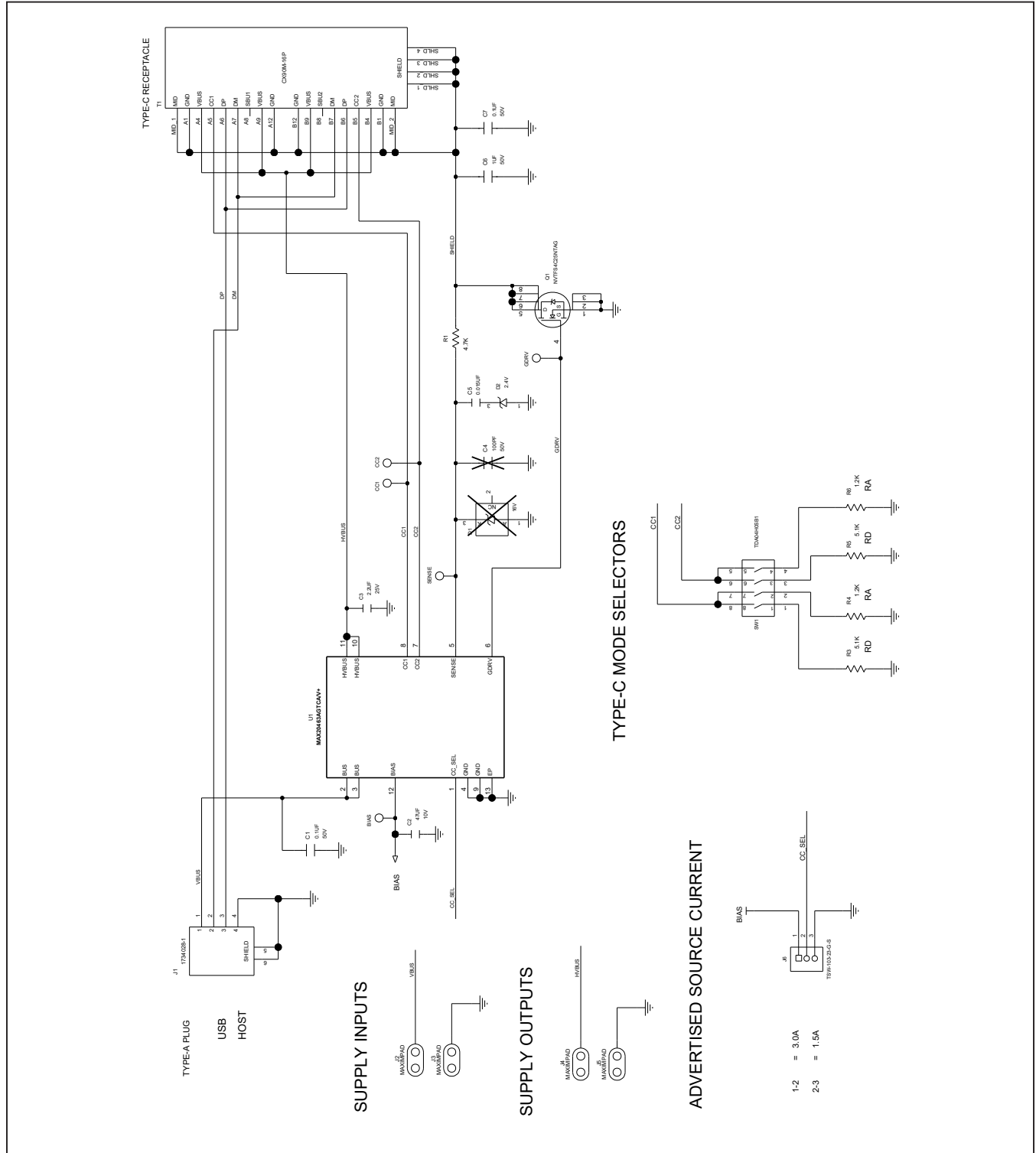

MAX20463A EV Kit PCB Layout Diagrams

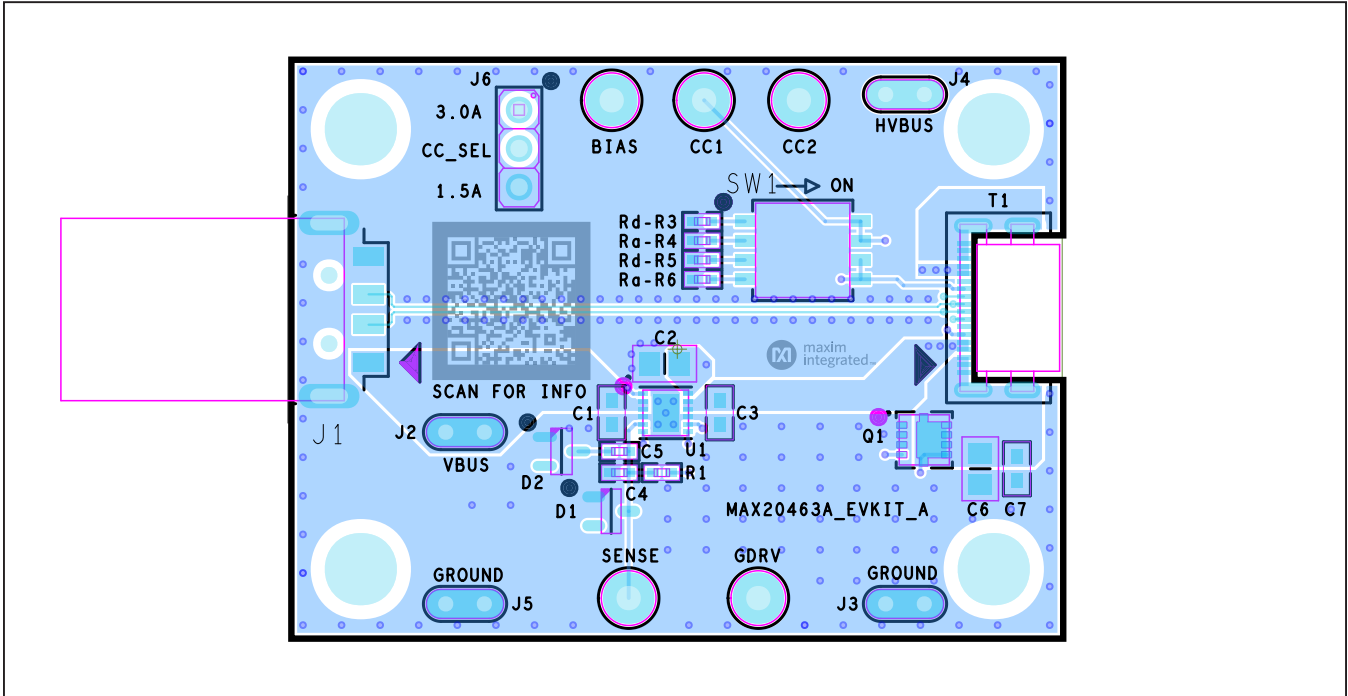

MAX20463A EV Kit PCB Layout — Top View

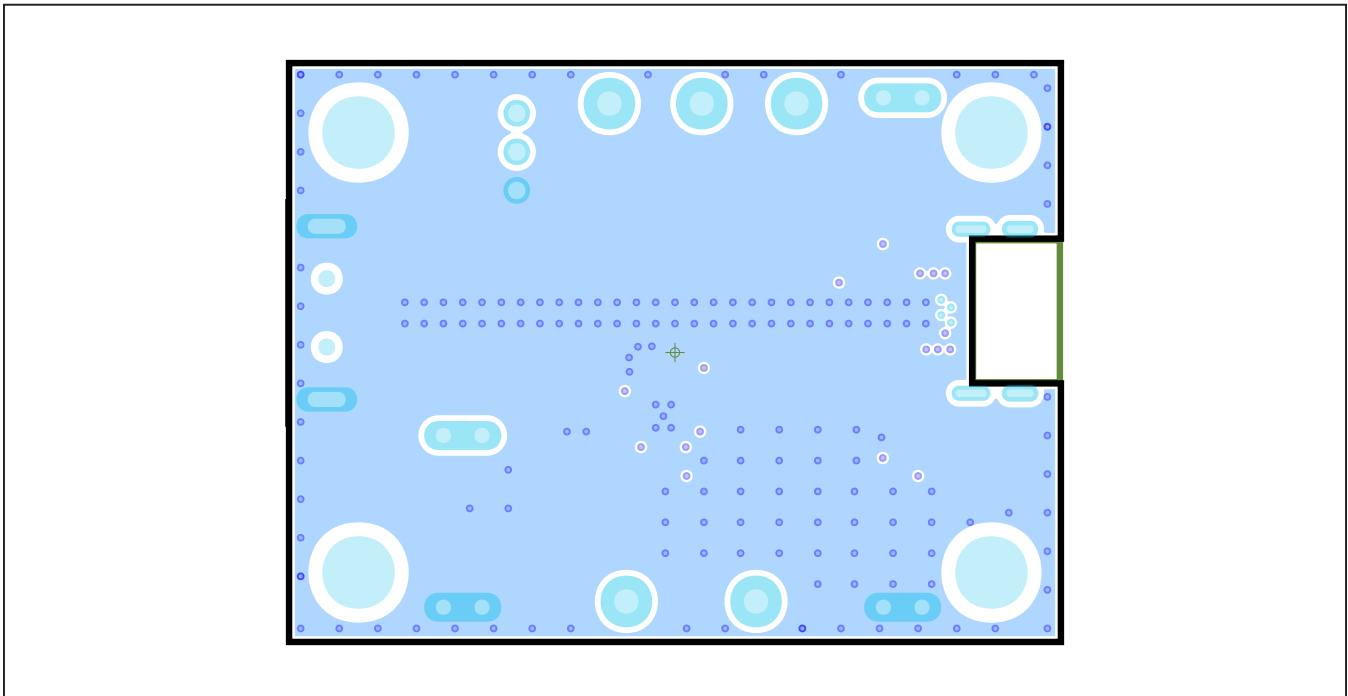

MAX20463A EV Kit PCB Layout — Layer 2

MAX20463A EV Kit PCB Layout Diagrams (continued)

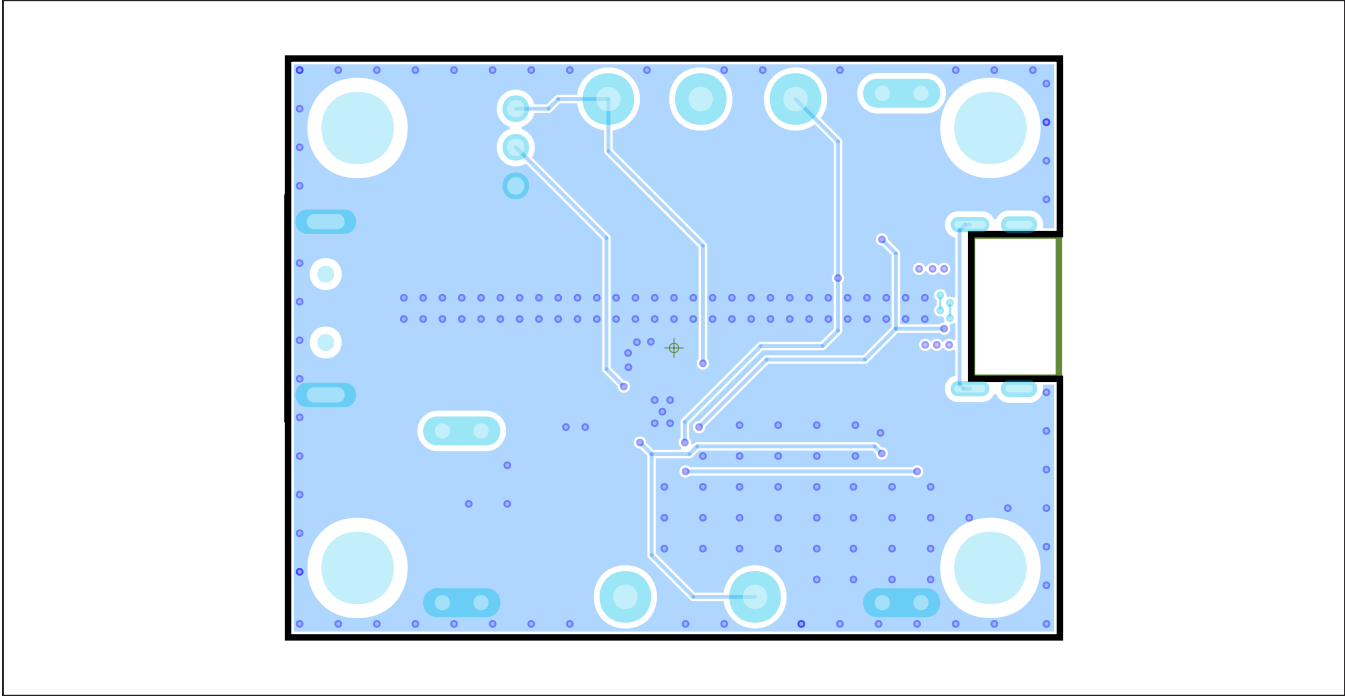

MAX20463A EV Kit PCB Layout — Layer 3

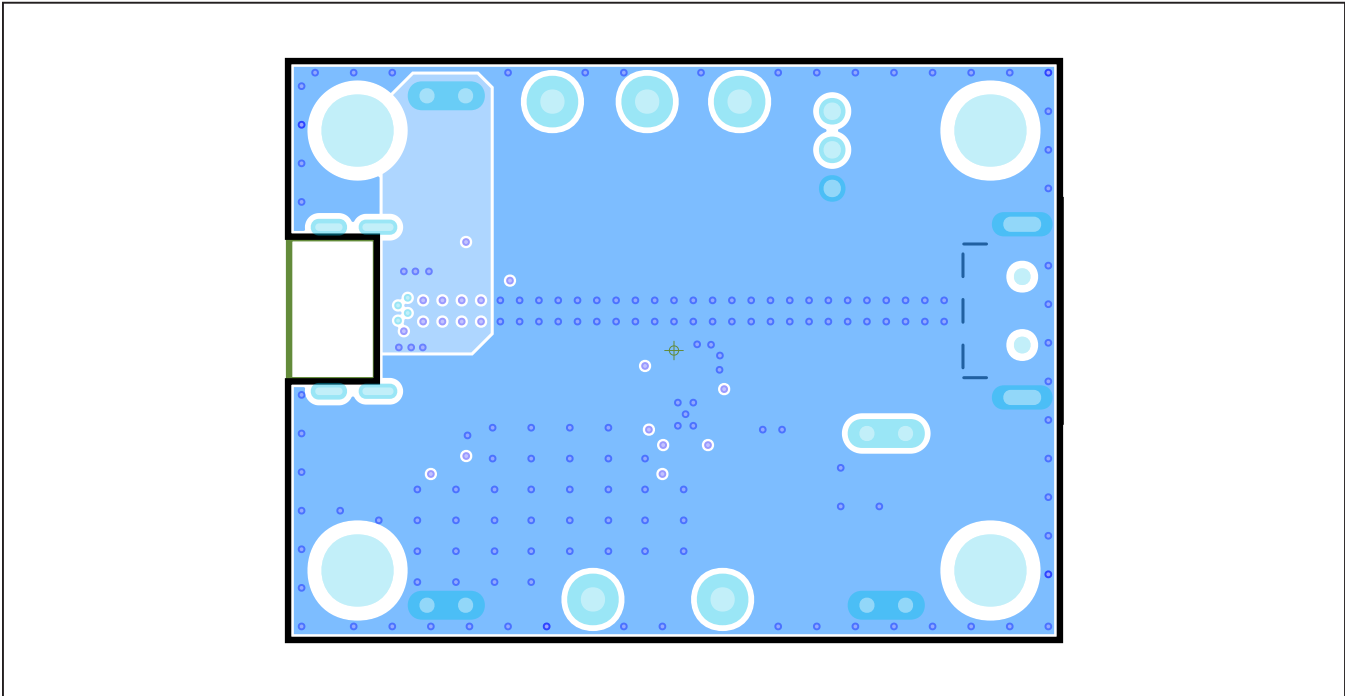

MAX20463A EV Kit PCB Layout — Bottom View

Revision History

REVISION NUMBER	REVISION DATE	DESCRIPTION	PAGES CHANGED
0	3/20	Initial release	—

For pricing, delivery, and ordering information, please visit Maxim Integrated's online storefront at <https://www.maximintegrated.com/en/storefront/storefront.html>.

Maxim Integrated cannot assume responsibility for use of any circuitry other than circuitry entirely embodied in a Maxim Integrated product. No circuit patent licenses are implied. Maxim Integrated reserves the right to change the circuitry and specifications without notice at any time.