

DM74ALS652/74ALS652-1 Octal 3-STATE Bus Transceiver and Register

General Description

This device incorporates an octal transceiver and an octal D-type register configured to enable transmission of data from bus to bus or internal register to bus.

This bus transceiver features totem-pole 3-STATE outputs designed specifically for driving highly-capacitive or relatively low-impedance loads. The high-impedance state and increased high level logic drive provide this device with the capability of being connected directly to and driving the bus lines in a bus organized system without need for interface or pull-up components. They are particularly attractive for implementing buffer registers, I/O ports, bidirectional bus drivers, and working registers.

The 'ALS652-1 version features the same performance as the standard versions, with the addition of increased current drive capability to meet the current requirements of various bus architectures. For all ALS-1 products, the recommended maximum I_{OL} is increased to 48 mA.

The registers in the 'ALS652 are edge-triggered D-type flip-flops. On the positive transition of the clock (CAB or CBA), the input data is stored into the appropriate register. The CAB input controls the transfer of data into the A register and the CBA input controls the B register.

The SAB and SBA control pins are provided to select whether real-time data or stored data is transferred. A low in-

put level selects real-time data and a high level selects stored data. The select controls have a "make before break" configuration to eliminate a glitch which would normally occur in a typical multiplexer during the transition between stored and real-time data.

The enable (GAB and $\overline{G}BA$) control pins provide four modes of operation: real-time data transfer from bus A to B, real-time data transfer from bus B to A, real-time bus A and/or B data transfer to internal storage, or internal stored data transfer to bus A and/or B.

Features

- Maximum I_{OL} increased to 48 mA for 'ALS652-1 product
- Switching specifications at 50 pF
- Switching specifications guaranteed over full temperature and V_{CC} range
- Advanced oxide-isolated, ion-implanted Schottky TTL process
- 3-STATE buffer-type outputs drive bus lines directly
- Independent registers and enables for A and B buses
- Multiplexed real-time and stored data

Connection Diagram

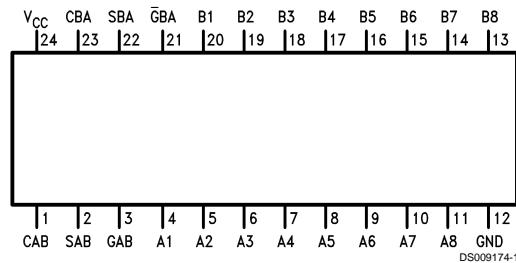

Order Number DM74ALS652NT, 74ALS652-1NT,
DM74ALS652WM or 74ALS652-1WM
See Package Number M24B or N24C

DM74ALS652/74ALS652-1 Octal 3-STATE Bus Transceiver and Register

Absolute Maximum Ratings (Note 2)

| | | | |
|--------------------------------|------|---------------------------|-----------------|
| Supply Voltage | 7V | Range | 0°C to +70°C |
| Input Voltage | | Storage Temperature Range | -65°C to +150°C |
| Control Inputs | 7V | Typical θ_{JA} | |
| I/O Ports | 5.5V | N Package | 44.5°C/W |
| Operating Free-Air Temperature | | M Package | 80.5°C/W |

Recommended Operating Conditions

| Symbol | Parameter | DM74ALS652/74ALS652-1 | | | Units |
|-----------|------------------------------------|-----------------------|-----|-----|-------|
| | | Min | Nom | Max | |
| V_{CC} | Supply Voltage | 4.5 | 5 | 5.5 | V |
| V_{IH} | High Level Input Voltage | 2 | | | V |
| V_{IL} | Low Level Input Voltage | | | 0.8 | V |
| I_{OH} | High Level Output Current | | | -15 | mA |
| I_{OL} | Low Level Output Current | ALS652 | | 24 | mA |
| | | ALS652-1 | | 48 | |
| f_{CLK} | Clock Frequency | 0 | | 40 | MHz |
| t_W | Pulse Duration, Clocks Low or High | 12.5 | | | ns |
| t_{SU} | Data Setup Time, A before CAB or | 10 \uparrow | | | ns |
| | B before CBA (Note 3) | | | | |
| t_H | Data Hold Time, A after CAB or | 0 \uparrow | | | ns |
| | B after CBA (Note 3) | | | | |
| T_A | Free Air Operating Temperature | 0 | | 70 | °C |

Note 1: This product meets application requirements of 500 temperature cycles from -65°C to +150°C.

Note 2: The "Absolute Maximum Ratings" are those values beyond which the safety of the device cannot be guaranteed. The device should not be operated at these limits. The parametric values defined in the "Electrical Characteristics" table are not guaranteed at the absolute maximum ratings. The "Recommended Operating Conditions" table will define the conditions for actual device operation.

Note 3: \uparrow = with reference to the low to high transition of the respective clock.

Electrical Characteristics

over recommended free air temperature range

| Symbol | Parameter | Test Conditions | Min | Typ | Max | Units | |
|----------|------------------------------------|---|-----------------------------------|--------------|------|-------|---------------|
| V_{IK} | Input Clamp Voltage | $V_{CC} = \text{Min}, I_I = -18 \text{ mA}$ | | | -1.2 | V | |
| V_{OH} | High Level Output Voltage | $V_{CC} = 4.5\text{V to } 5.5\text{V}$ | $I_{OH} = -0.4 \text{ mA}$ | $V_{CC} - 2$ | | V | |
| | | $V_{CC} = \text{Min}$ | $I_{OH} = -3 \text{ mA}$ | 2.4 | 3.2 | | |
| | | | $I_{OH} = \text{Max}$ | 2 | | | |
| V_{OL} | Low Level Output Voltage | $V_{CC} = \text{Min}$ | $I_{OL} = 12 \text{ mA}$ | | 0.25 | 0.4 | V |
| | | | $I_{OL} = 24 \text{ mA}$ | | 0.35 | 0.5 | |
| | | | $I_{OL} = 48 \text{ mA}$ | | 0.35 | 0.5 | |
| I_I | Input Current at Max Input Voltage | $V_{CC} = \text{Max}$ | I/O Ports, $V_I = 5.5\text{V}$ | | | 100 | μA |
| | | | Control Inputs, $V_I = 7\text{V}$ | | | 100 | |
| I_{IH} | High Level Input Current | $V_{CC} = \text{Max}, V_I = 2.7\text{V}$, (Note 4) | | | | 20 | μA |
| I_{IL} | Low Level Input Current | $V_{CC} = \text{Max}, V_I = 0.4\text{V}$ (Note 4) | Control Inputs | | | -200 | μA |
| | | | I/O Ports | | | -200 | |
| I_O | Output Drive Current | $V_{CC} = \text{Max}, V_O = 2.25\text{V}$ | -30 | | | -112 | mA |
| I_{CC} | Supply Current | $V_{CC} = \text{Max}$ | Outputs High | | 47 | 76 | mA |
| | | | Outputs Low | | 55 | 88 | |
| | | | Outputs Disabled | | 55 | 88 | |

Note 4: For I/O ports the 3-STATE output currents (I_{OZH} and I_{OZL}) are included in the I_{IH} and I_{IL} parameters.

Switching Characteristics

over recommended operating free air temperature range (Notes 5, 6)

| Symbol | Parameter | Conditions | From (Input) To (Output) | DM74ALS652/ 74ALS652-1 | | Units |
|------------------|--|--|---------------------------------|---------------------------|-----|-------|
| | | | | Min | Max | |
| t _{PLH} | Propagation Delay Time Low to High Level Output | V _{CC} = 4.5V to 5.5V, C _L = 50 pF, R ₁ = R ₂ = 500Ω, T _A = Min to Max | CBA or CAB to A or B | 10 | 30 | ns |
| t _{PHL} | Propagation Delay Time High to Low Level Output | | CBA or CAB to A or B | 5 | 17 | ns |
| t _{PLH} | Propagation Delay Time Low to High Level Output | | A or B to B or A | 5 | 18 | ns |
| t _{PHL} | Propagation Delay Time High to Low Level Output | | A or B to B or A | 3 | 12 | ns |
| t _{PLH} | Propagation Delay Time Low to High Level Output (with A or B Low) (Note 6) | | SBA or SAB to A or B | 12 | 35 | ns |
| t _{PHL} | Propagation Delay Time High to Low Level Output (with A or B Low) (Note 6) | | SBA or SAB to A or B | 6 | 20 | ns |
| t _{PLH} | Propagation Delay Time Low to High Level Output (with A or B High) (Note 6) | | SBA or SAB to A or B | 6 | 25 | ns |
| t _{PHL} | Propagation Delay Time High to Low Level Output (with A or B High) (Note 6) | | SBA or SAB to A or B | 5 | 20 | ns |
| t _{PZH} | Output Enable Time to High Level Output | | $\overline{\text{GBA}}$ to A | 3 | 17 | ns |
| t _{PZL} | Output Enable Time to Low Level Output | | $\overline{\text{GBA}}$ to A | 5 | 18 | ns |
| t _{PHZ} | Output Disable Time from High Level Output | | $\overline{\text{GBA}}$ to A | 1 | 10 | ns |
| t _{PLZ} | Output Disable Time from Low Level Output | | $\overline{\text{GBA}}$ to A | 2 | 16 | ns |
| t _{PZH} | Output Enable Time to High Level Output | | GAB to B | 6 | 22 | ns |
| t _{PZL} | Output Enable Time to Low Level Output | | GAB to B | 6 | 18 | ns |
| t _{PHZ} | Output Disable Time from High Level Output | | GAB to B | 1 | 10 | ns |
| t _{PLZ} | Output Disable Time from Low Level Output | | GAB to B | 2 | 16 | ns |

Note 5: See Section 1 for test waveforms and output load.

Note 6: These parameters are measured with the internal output state of the storage register opposite to that of the bus input.

Function Table

| Inputs | | | | | | Data I/O (Note 7) | | Operation or Function |
|--------|-------------|------------|------------|------------|------------|-------------------|---------------|---------------------------|
| GAB | $\bar{G}BA$ | CAB | CBA | SAB | SBA | A1 thru A8 | B1 thru B8 | |
| X | H | \uparrow | H/L | X | X | Input | Not Specified | Store A, Hold B |
| L | X | H/L | \uparrow | X | X | Not Specified | Input | Store B, Hold A |
| L | H | \uparrow | \uparrow | X | X | Input | Input | Store A and B Data |
| L | H | H/L | H/L | X | X | Input | Input | Isolation, Hold Storage |
| L | L | X | X | X | L | Output | Input | Real-Time B Data to A Bus |
| L | L | X | H/L | X | H | Output | Input | Stored B Data to A Bus |
| H | H | X | X | L | X | Input | Output | Real-Time A Data to B Bus |
| H | H | \uparrow | \uparrow | X | X | Input | Output | Stored A Data to B Bus |
| H | H | \uparrow | \uparrow | X (Note 8) | X | Input | Output | Store A in both Registers |
| L | L | \uparrow | \uparrow | X | X (Note 8) | Output | Input | Store B in both Registers |

Note 7: The data output functions may be enabled or disabled by various signals at the \bar{G} and DIR inputs. Data input functions are always enabled, i.e., data at the bus pins will be stored on every low-to-high transition on the clock inputs.

Note 8: Select control = L; clocks can occur simultaneously

Select control = H; clocks must be staggered in order to load both registers.

H = High Logic Level, L = Low Logic Level, X = Don't Care (Either Low or High Logic Levels, including transitions), H/L = Either Low or High Logic Level excluding transitions, \uparrow = Positive-going edge of pulse.

Logic Diagram

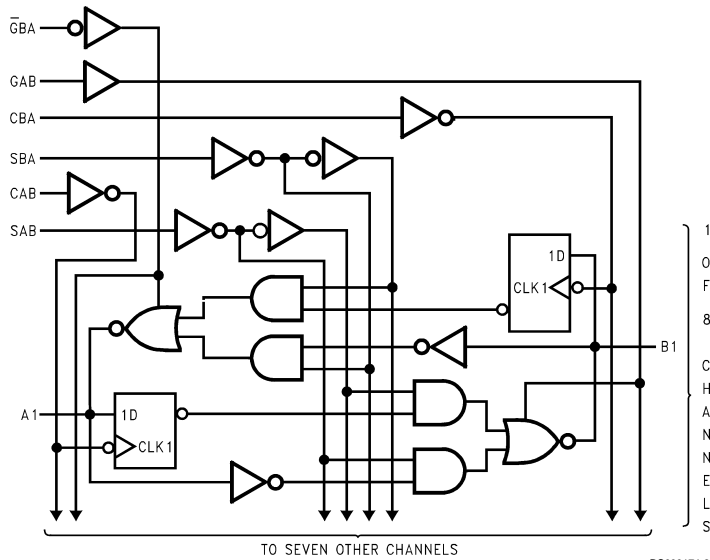

Physical Dimensions inches (millimeters) unless otherwise noted

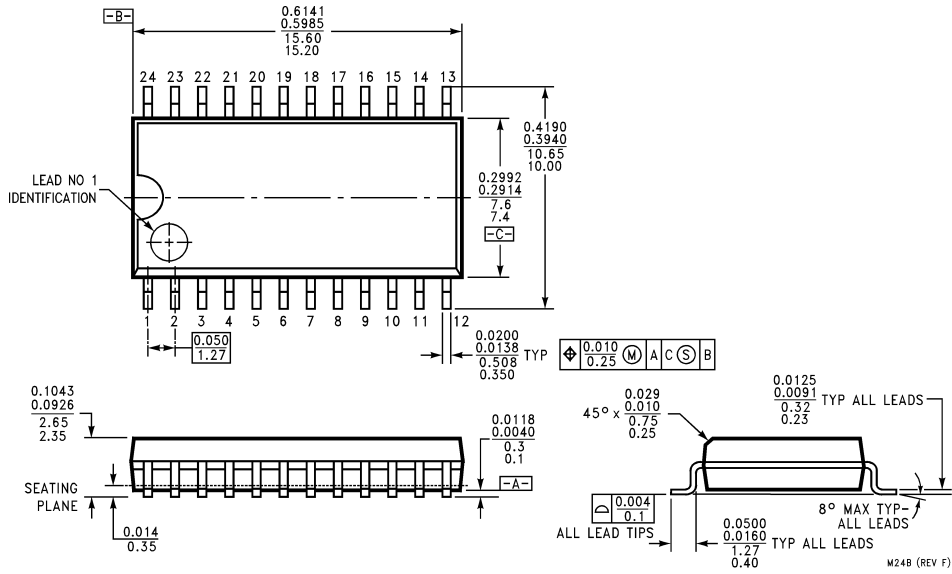

S.O. Package (WM)
Order Number DM74ALS652WM or 74ALS652-1WM
Package Number M24B

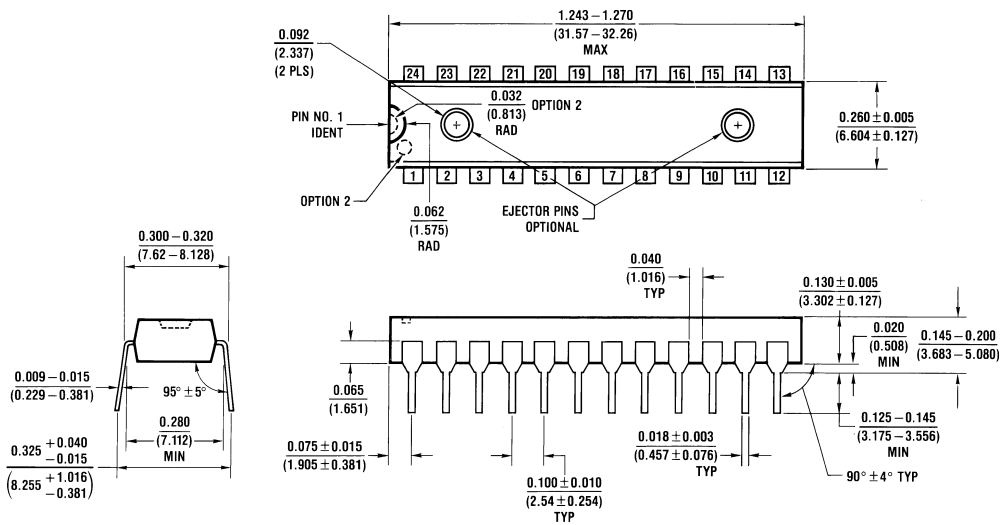

Molded Dual-In-Line Package (NT)
Order Number DM74ALS652NT or 74ALS652-1NT
Package Number N24C

LIFE SUPPORT POLICY

FAIRCHILD'S PRODUCTS ARE NOT AUTHORIZED FOR USE AS CRITICAL COMPONENTS IN LIFE SUPPORT DEVICES OR SYSTEMS WITHOUT THE EXPRESS WRITTEN APPROVAL OF THE PRESIDENT OF FAIRCHILD SEMICONDUCTOR CORPORATION. As used herein:

1. Life support devices or systems are devices or systems which, (a) are intended for surgical implant into the body, or (b) support or sustain life, and (c) whose failure to perform when properly used in accordance with instructions for use provided in the labeling, can be reasonably expected to result in a significant injury to the user.
2. A critical component in any component of a life support device or system whose failure to perform can be reasonably expected to cause the failure of the life support device or system, or to affect its safety or effectiveness.

Fairchild Semiconductor Corporation Americas
Customer Response Center
Tel: 1-888-522-5372

Fairchild Semiconductor Europe
Fax: +49 (0) 1 80-530 85 86
Email: europe.support@nsc.com
Deutsch Tel: +49 (0) 8 141-35-0
English Tel: +44 (0) 1 793-85-68-56
Italy Tel: +39 (0) 2 57 5631

Fairchild Semiconductor Hong Kong Ltd.
13th Floor, Straight Block,
Ocean Centre, 5 Canton Rd.
Tsimshatsui, Kowloon
Hong Kong
Tel: +852 2737-7200
Fax: +852 2314-0061

National Semiconductor Japan Ltd.
Tel: 81-3-5620-6175
Fax: 81-3-5620-6179

www.fairchildsemi.com