

ECN/PCN No.: M1148

For Manufacturer

Product Description: Wireless Charging Coil Assembly		Abracon Part Number / Part Series: AWCCA-38R32 Series	<input checked="" type="checkbox"/> Series
Affected Revision: C	New Revision: D	Application	<input type="checkbox"/> Part Number
			<input type="checkbox"/> Safety
			<input checked="" type="checkbox"/> Non-Safety

Prior to Change:

Section 5.0 Markings

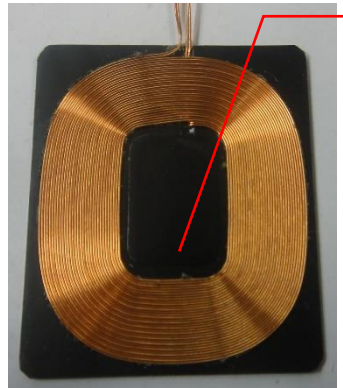

**AWCCA-
38R32H09-C01-B
YYWW**

← Part Number

← Date Code
YY: Year: E.G. 19 for 2019
WW: Week: E.g. 05 for the 5th week of the year

Section 6.0 Outline Dimensions (unit mm)

1. Dimension I: 38.5 mm +/- 1.0
2. Dimension J: 32.5 mm +/- 1.0
3. Dimension K: 1.0 mm MAX

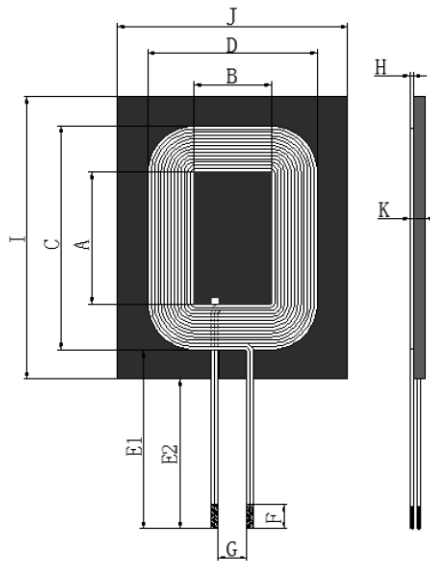

A	B	C	D	E1	E2	F	G	H	I	J	K
17.5	12.6	35.3	30.2	53.0	50.0	5.0	5.0	0.38	38.0	32.5	1.0
±0.5	±0.5	±1.5	±1.5	Ref.	±3.0	Ref.	Ref.	±0.10	±1.0	±1.0	Max.

Section 6.1 Winding Specifications

Number of Coils	Wire	Number of Turns	Inductance
1	φ 0.25×2	14 REF	11.1μH ±10%

After Change:

Section 5.0 Markings: None

Section 6.0 Outline Dimensions (unit mm)

1. Dimension I: 39.0 mm MAX
2. Dimension J: 33.0 mm MAX
3. Dimension K: 1.3 mm MAX

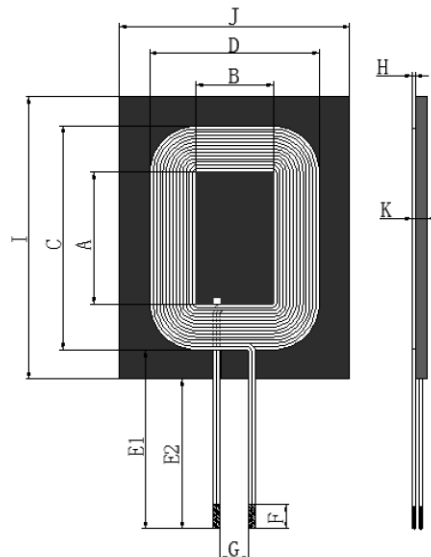

A	B	C	D	E1	E2	F	G	H	I	J	K
17.5	12.6	35.3	30.2	53.0	50.0	5.0	5.0	0.38	39.0	33.0	1.30
±0.5	±0.5	±1.5	±1.5	Ref.	±3.0	Ref.	Ref.	±0.10	Max.	Max.	Max.

Section 6.1 Winding Specifications

Number of Coils	Wire	Number of Turns	Inductance
1	φ 0.25×2	16 REF	11.1μH ±10%

Cause/Reason for Change:

Minor dimension change to align production to standard ferrite sheet size.

Change Plan	Effective Date: 2/13/2020	Additional Remarks: N/A
--------------------	-------------------------------------	-----------------------------------

Change Declaration:

The changes attached do not negatively impact electrical or mechanical performance of this series. The change in dimension is smaller than original while keeping the same recommended landing pattern.

Issued Date: 2/13/2020	Issued By: Gerald Capwell	Issued Department: Engineering
Approval: Syed Raza Engineering VP	Approval: Reuben Quintanilla Quality Manager	Approval: Ying Huang Purchasing Director

For Abracon EOL only

Last Time Buy (if applicable): N/A	Alternate Part Number / Part Series: N/A	
Additional Approval: N/A	Additional Approval: N/A	Additional Approval: N/A

Customer Approval (If Applicable)

Qualification Status: <input type="checkbox"/> Approved <input type="checkbox"/> Not accepted Note: It is considered approved if there is no feedback from customer 1 month after ECN/PCN is released		
Customer Part Number:	Customer Project:	
Company Name:	Company Representative:	Representative Signature:
Customer Remarks:		