



Overview

KEMET's U2J KONNEKT surface mount capacitors are designed for high-efficiency and high-density power applications. KONNEKT utilizes an innovative Transient Liquid Phase Sintering (TLPS) material to create a leadless multi-chip solution. When combined with KEMET's ultra-stable U2J dielectric, KONNEKT enables a low-loss, low-inductance package capable of handling extremely high ripple currents in the hundreds of kilohertz.

U2J is an extremely stable Class I dielectric material that exhibits a negligible shift in capacitance with respect to

voltage and a predictable and linear change in capacitance with reference to ambient temperature, with minimal aging effect. Capacitance change is limited to -750 ± 120 ppm/°C from -55°C to $+125^{\circ}\text{C}$.

U2J KONNEKT can also be mounted in a low-loss orientation to further increasing its power handling capability. The low-loss orientation lowers ESR (Effective Series Resistance) and ESL (Effective Series Inductance) which increases ripple current handling capability.

Benefits

- Extremely high-power density and ripple current capability
- Extremely low equivalent series resistance (ESR)
- Extremely low equivalent series inductance (ESL)
- Operating temperature range of -55°C to $+125^{\circ}\text{C}$
- Retains over 99% of nominal capacitance at full rated voltage
- Low noise
- Surface mountable using standard MLCC reflow profiles
- Low-loss orientation option for higher current handling capability
- RoHS compliant and Pb-free

Applications

- Wide bandgap (WBG), silicon carbide (SiC) and gallium nitride (GaN) systems
- Data centers
- LLC resonant converters
- Switched tank converters
- Wireless charging systems
- Photovoltaic systems
- Power converters
- Inverters
- DC link
- Snubber

Standard



Low Loss

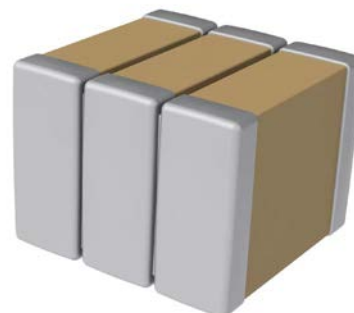

Typical Performance

Part Type	Mounting Configuration	Typical ESR at 25°C, 100 kHz	Typical ESL at 25°C	Typical Ripple Current (A_{rms}) ¹		
				100 kHz	200 kHz	300 kHz
1812 940 nF	Standard	1.15 mΩ	1.1 nH	12.0	12.0	11.5
	Low Loss	0.77 mΩ	0.45 nH	18.0	18.0	16.0
1812 1.4 μF	Standard	1.3 mΩ	1.6 nH	11.0	10.0	10.0
	Low Loss	0.35 mΩ	0.4 nH	20.0	34.0	31.0

¹ Ripple current measurements performed at 85°C with a peak capacitor temperature of 95°C. Samples mounted to heat sink with no forced air cooling. Maximum ambient and self heating cannot exceed 125°C.

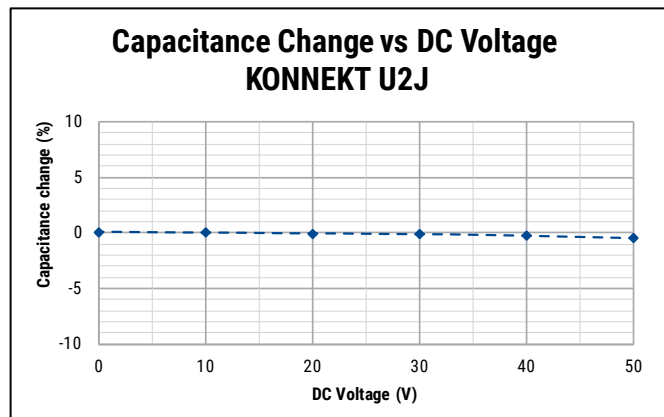
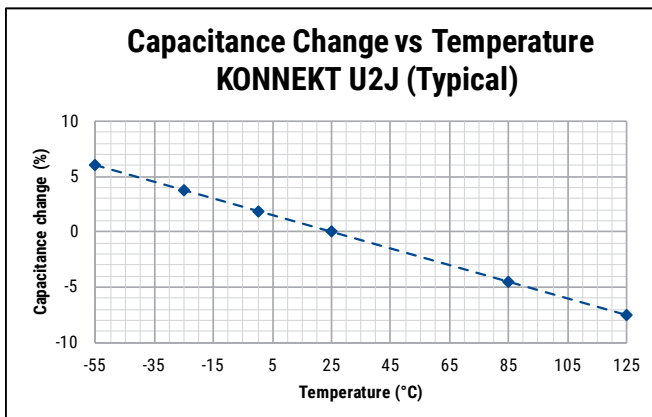
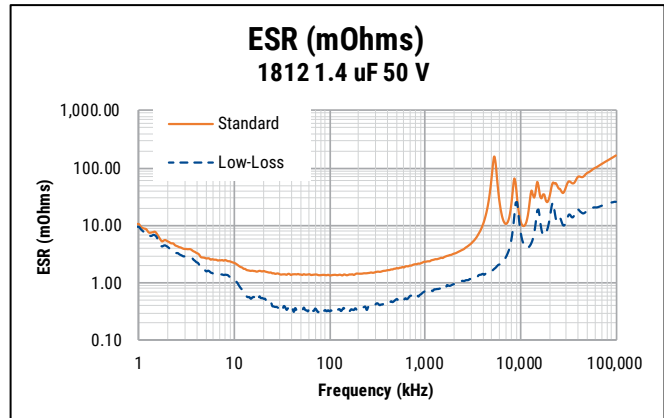
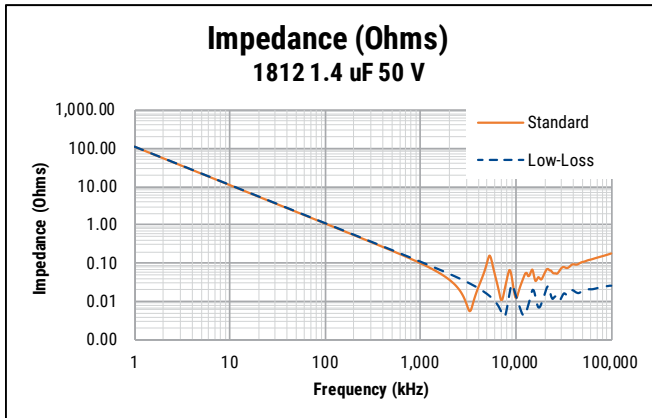
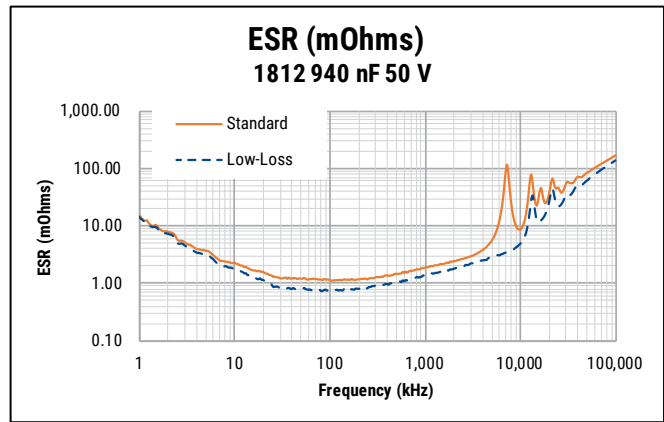
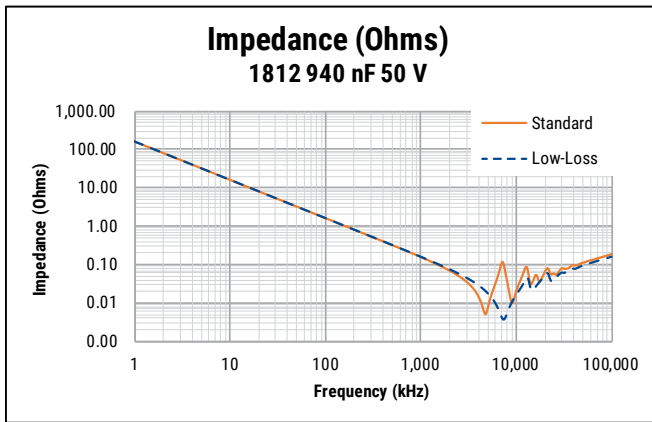

Typical Performance cont.

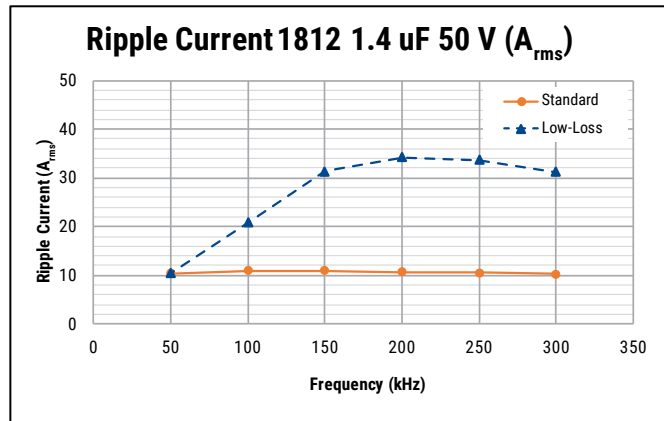
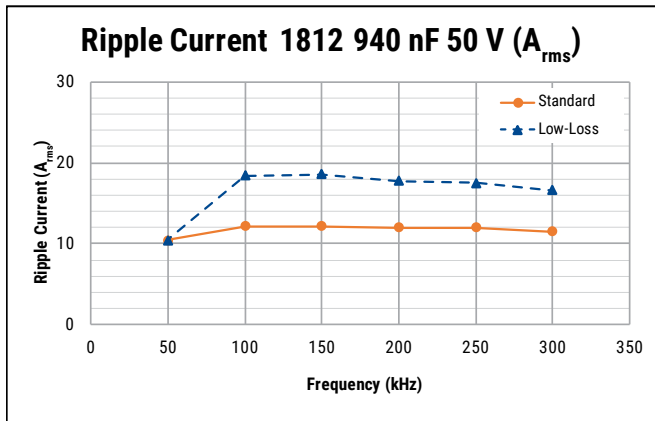

Electrical Parameters/Characteristics

Item	Parameters/Characteristics
Operating temperature range	-55°C to +125°C
Capacitance change with reference to +25°C and 0 VDC applied (TCC)	-750 \pm 120 ppm/°C
Aging rate (maximum % capacitance loss/decade hour)	0.1%
¹ Dielectric withstanding voltage (DWV)	250% of rated voltage (5 \pm 1 seconds and charge/discharge not exceeding 50 mA)
² Dissipation factor (DF) maximum limit at 25°C	0.1%
³ Insulation resistance (IR) minimum limit at 25°C	1,000 M Ω - μ F or 100 G Ω (Rated voltage applied for 120 \pm 5 seconds at 25°C)

¹ DWV is the voltage a capacitor can withstand (survive) for a short period of time. It exceeds the nominal and continuous working voltage of the capacitor.

² Capacitance and dissipation factor (DF) measured under the following conditions:
 1 kHz \pm 50 Hz and 1.0 \pm 0.2 V_{rms}

³ To obtain IR limit, divide M Ω - μ F value by the capacitance and compare to G Ω limit. Select the lower of the two limits.



Note: When measuring capacitance it is important to ensure the set voltage level is held constant. The HP4284 and Agilent E4980 have a feature known as Automatic Level Control (ALC). The ALC feature should be switched to "ON."

Ordering Information

C	1812	C	145	J	5	J	L	C	7XXX
Series	Case Size (L" x W")	Specification/ Series	Capacitance Code (pF)	Capacitance Tolerance	Rated Voltage (V)	Dielectric	Subclass Designation	Termination Finish	Packaging (Suffix/C-Spec)
C = Ceramic	1812	C = Standard	Two single digits and number of zeros.	J = \pm 5% K = \pm 10%	5 = 50 V	J = U2J	L = KONNEKT	C = 100% matte Sn	See "Packaging C-Spec Ordering Options Table"

See Table 1A for available capacitance and voltage ratings.

Packaging C-Spec Ordering Options Table

Mounting Orientation		Packaging Type	Packaging/Grade Ordering Code (C-Spec)
Standard		7" Reel/Unmarked	TU (7800)
		13" Reel/Unmarked	7210
Low Loss		7" Reel/Unmarked	7805
		13" Reel/Unmarked	7810

Dimensions – Millimeters (Inches)

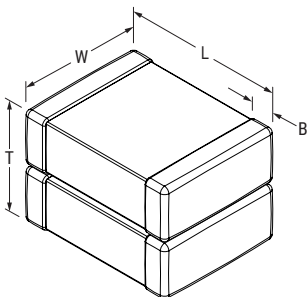
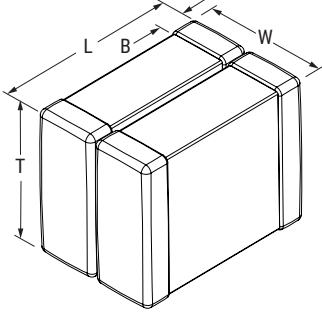
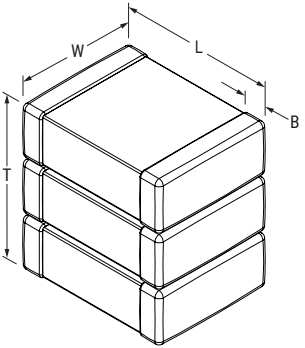
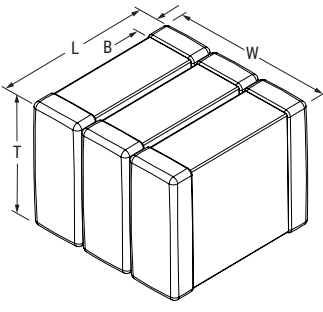
Standard Mounting 2 Chips	Low Loss Mounting 2 Chips	Standard Mounting 3 Chips	Low Loss Mounting 3 Chips
			

Number of Chips	Mounting	EIA SIZE CODE	METRIC SIZE CODE	L LENGTH	W WIDTH	T THICKNESS	B BANDWIDTH	Mounting Technique
2	Standard	1812	4532	4.50 (0.177) ±0.30 (0.012)	3.2 (0.126) ±0.3 (0.012)	3.5 (0.137) ±0.4 (0.016)	0.6 (0.024) ±0.35 (0.014)	Solder Reflow Only
	Low Loss				3.5 (0.137) ±0.4 (0.016)	3.2 (0.126) ±0.3 (0.012)		
3	Standard				3.2 (0.126) ±0.3 (0.012)	5.3 (0.208) ±0.6 (0.024)		
	Low Loss				5.3 (0.208) ±0.6 (0.024)	3.2 (0.126) ±0.3 (0.012)		

Table 1A – Product Ordering Codes & Ratings

Capacitance	Capacitance Code	Chip Number	Case Size		1812
			Voltage Code		5
			Rated Voltage (VDC)		50
			Capacitance Tolerance		
940 nF	944	2	J	K	•
1.4 uF	145	3	J	K	•

Table 1B – Chip Thickness/Tape & Reel Packaging Quantities

Case Size	Chip Number	Orientation	Thickness ± Range (mm)	Plastic Quantity	
				7" Reel	13" Reel
1812	2	Standard	3.5±0.40	500	2,000
		Low Loss	3.2±0.30	500	2,200
	3	Standard	5.3±0.60	200	900
		Low Loss	3.2±0.30	500	2,200

Table 2 – Performance & Reliability: Test Methods and Conditions (Commercial Only)

Stress	Reference	Test or Inspection Method
Terminal Strength	JIS-C-6429	Appendix 1, Note: Force of 1.8 kg for 60 seconds
Board Flex	JIS-C-6429	Appendix 2, Note: 3.0 mm (minimum)
Solderability	KEMET Custom Test	1. Board shear – SAC305 solder. Shear force of 1.8 kg (minimum)
		2. Wetting balance – IEC 60068-2-69
Temperature Cycling	JESD22 Method JA-104	1,000 cycles (-55°C to +125°C), measurement at 24 hours ±4 hours after test conclusion.
Biased Humidity	MIL-STD-202 Method 103	Load humidity: 1,000 hours 85°C/85% RH and rated voltage. Add 100 K ohm resistor. Measurement at 24 hours ±4 hours after test conclusion.
		Low volt humidity: 1,000 hours 85°C/85% RH and 1.5 V. Add 100 K ohm resistor. Measurement at 24 hours ±4 hours after test conclusion.
High Temperature Life	MIL-STD-202 Method 108/EIA-198	1,000 hours at 125°C with 1.0 X rated voltage applied.
Storage Life	MIL-STD-202 Method 108	125°C, 0 VDC, for 1,000 hours.
Vibration	MIL-STD-202 Method 204	5 g for 20 minutes, 12 cycles each of 3 orientations. Note: Use 8" X 5" PCB 0.031" thick 7 secure points on one long side and 2 secure points at corners of opposite sides. Parts mounted within 2" from any secure point. Test from 10 – 2,000 Hz.
Mechanical Shock	MIL-STD-202 Method 213	Figure 1 of Method 213, condition F.
Resistance to Solvents	MIL-STD-202 Method 215	Add aqueous wash chemical, OKEM Clean or equivalent.

Environmental Compliance

Lead (Pb)-free, RoHS, and REACH compliant without exemptions.

Table 3 – KONNEKT Land Pattern Design Recommendations per IPC-7351 (mm)

Chip Number	Orientation	EIA SIZE CODE	METRIC SIZE CODE	Median (Nominal) Land Protrusion				
				C	Y	X	V1	V2
2	Standard and Low Loss	1812	4532	2.05	1.40	3.50	6.00	4.00
3	Standard			2.05	1.40	3.50	6.00	4.00
	Low loss			2.05	1.40	5.90	6.00	6.40

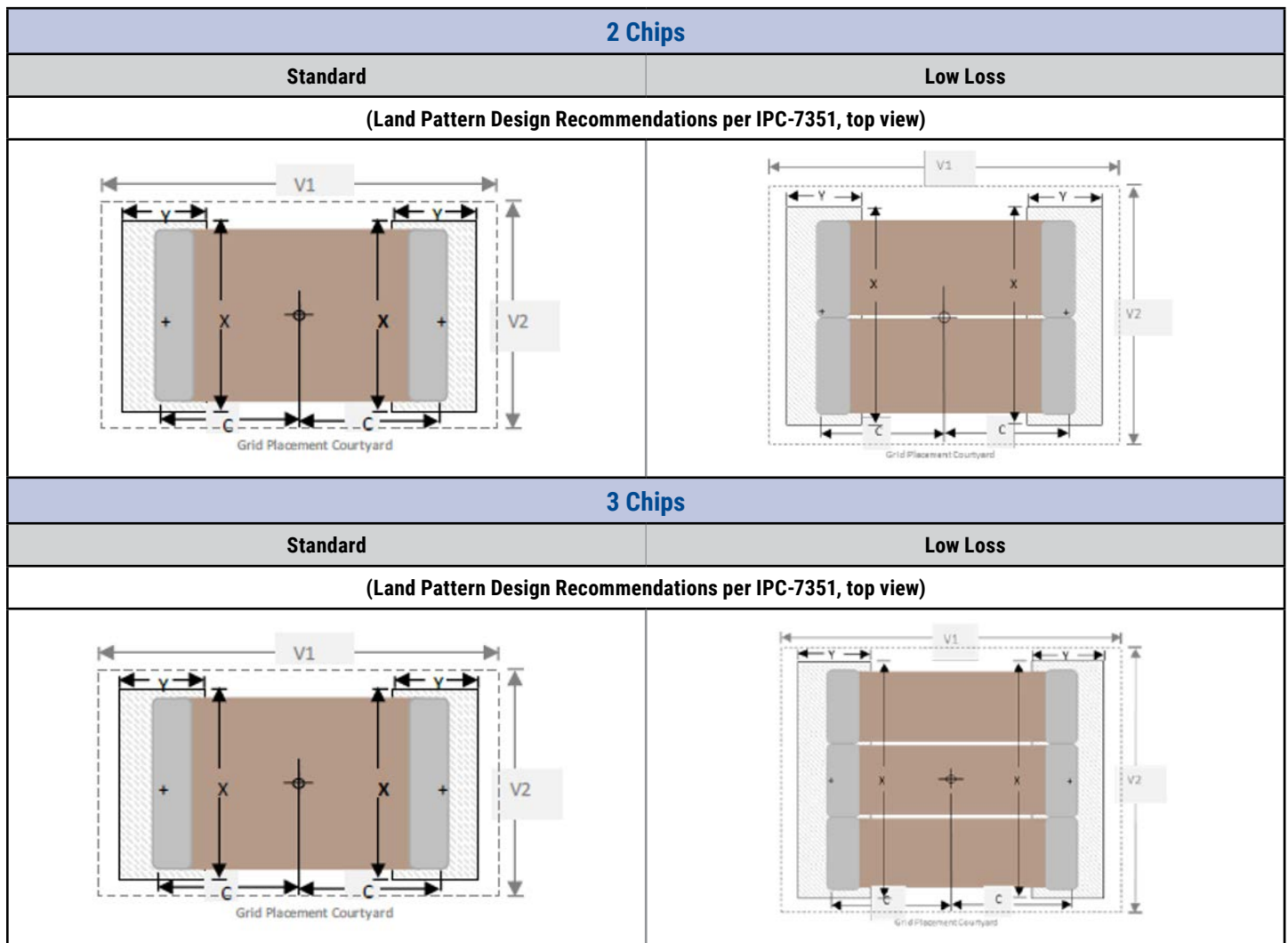

Soldering Process

Recommended Reflow Soldering Profile

KEMET's KONNEKT family of high density surface mount multilayer ceramic capacitors (SMD MLCCs) are compatible with convection and IR reflow techniques. Preheating of these components is recommended to avoid extreme thermal stress. KEMET's recommended profile conditions for convection and IR reflow reflect the profile conditions of the IPC/J-STD-020 standard for moisture sensitivity testing. These devices can safely withstand a maximum of three reflow passes at these conditions.

Profile Feature	Termination Finish
	100% matte Sn
Preheat/Soak	
Temperature Minimum (T_{smin})	150°C
Temperature Maximum (T_{smax})	200°C
Time (t_s) from T_{smin} to T_{smax}	60 – 120 seconds
Ramp-Up Rate (T_L to T_p)	3°C/second maximum
Liquidous Temperature (T_L)	217°C
Time Above Liquidous (t_L)	60 – 150 seconds
Peak Temperature (T_p)	260°C
Time Within 5°C of Maximum Peak Temperature (t_p)	30 seconds maximum
Ramp-Down Rate (T_p to T_L)	6°C/second maximum
Time 25°C to Peak Temperature	8 minutes maximum

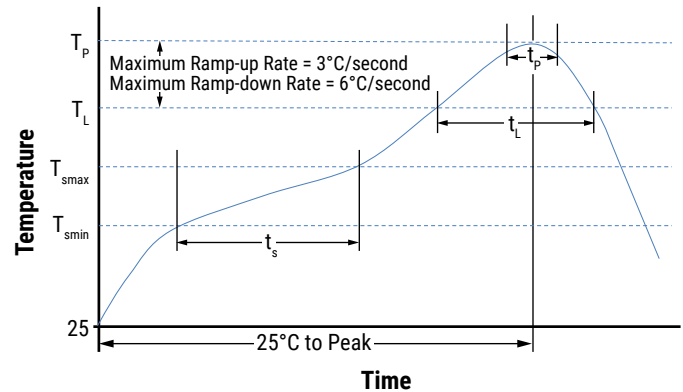

Note: All temperatures refer to the center of the package, measured on the capacitor body surface that is facing up during assembly reflow.

Storage & Handling

Ceramic chip capacitors should be stored in normal working environments. While the chips themselves are quite robust in other environments, solderability will be degraded by exposure to high temperatures, high humidity, corrosive atmospheres, and long term storage. In addition, packaging materials will be degraded by high temperature – reels may soften or warp and tape peel force may increase. KEMET recommends that maximum storage temperature not exceed 40°C and maximum storage humidity not exceed 70% relative humidity. In addition, temperature fluctuations should be minimized to avoid condensation on the parts and atmospheres should be free of chlorine and sulfur bearing compounds. For optimized solderability chip stock should be used promptly, preferably within 1.5 years upon receipt.

Construction

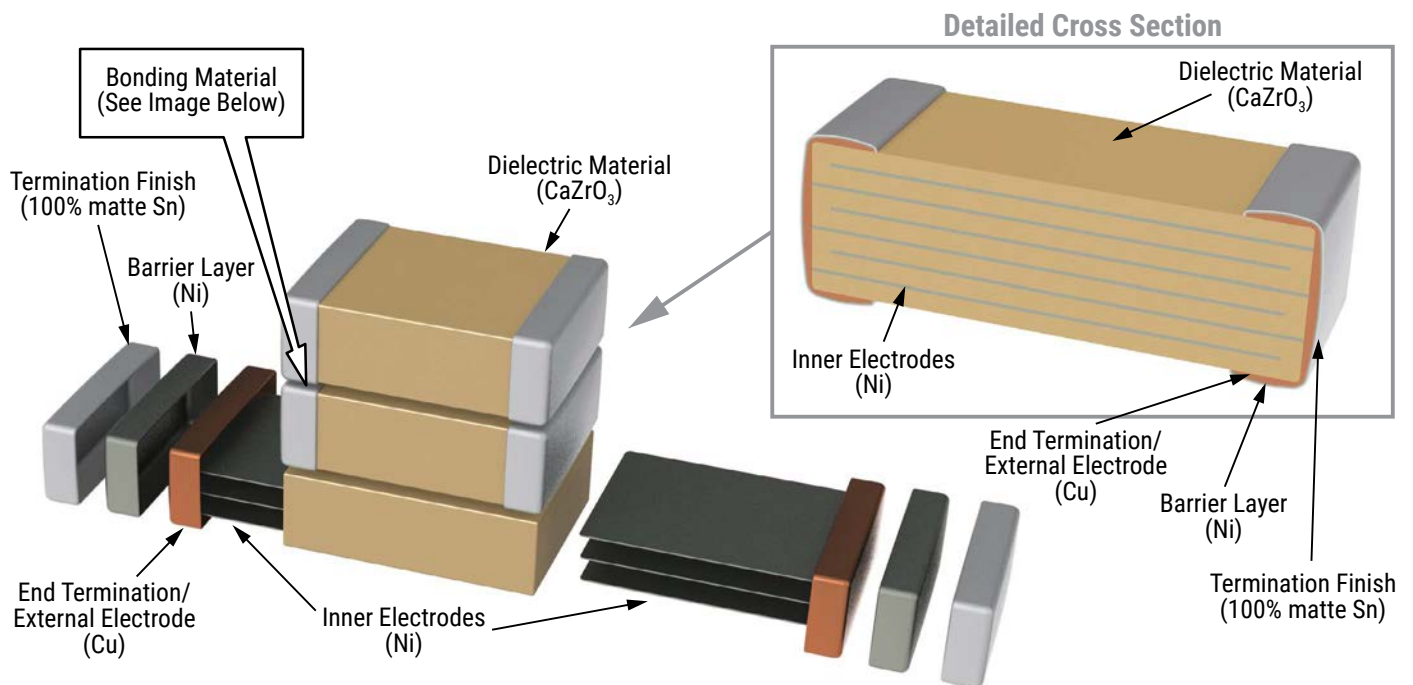

Bonding Material

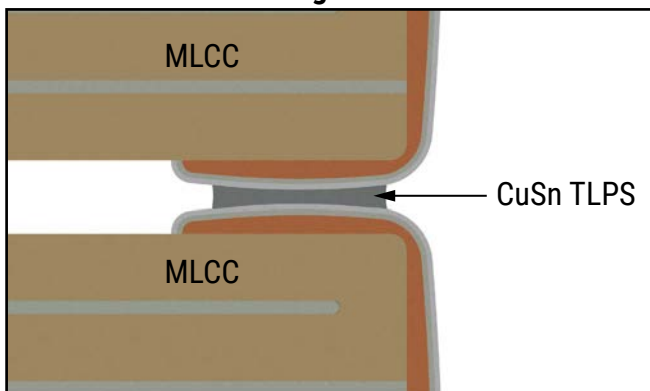

Tape & Reel Packaging Information

KEMET offers multilayer ceramic chip capacitors packaged in 8, 12, 16 and 24 mm tape on 7" and 13" reels in accordance with EIA Standard 481. This packaging system is compatible with all tape-fed automatic pick and place systems. See Table 1B for details on reeling quantities for commercial chips.

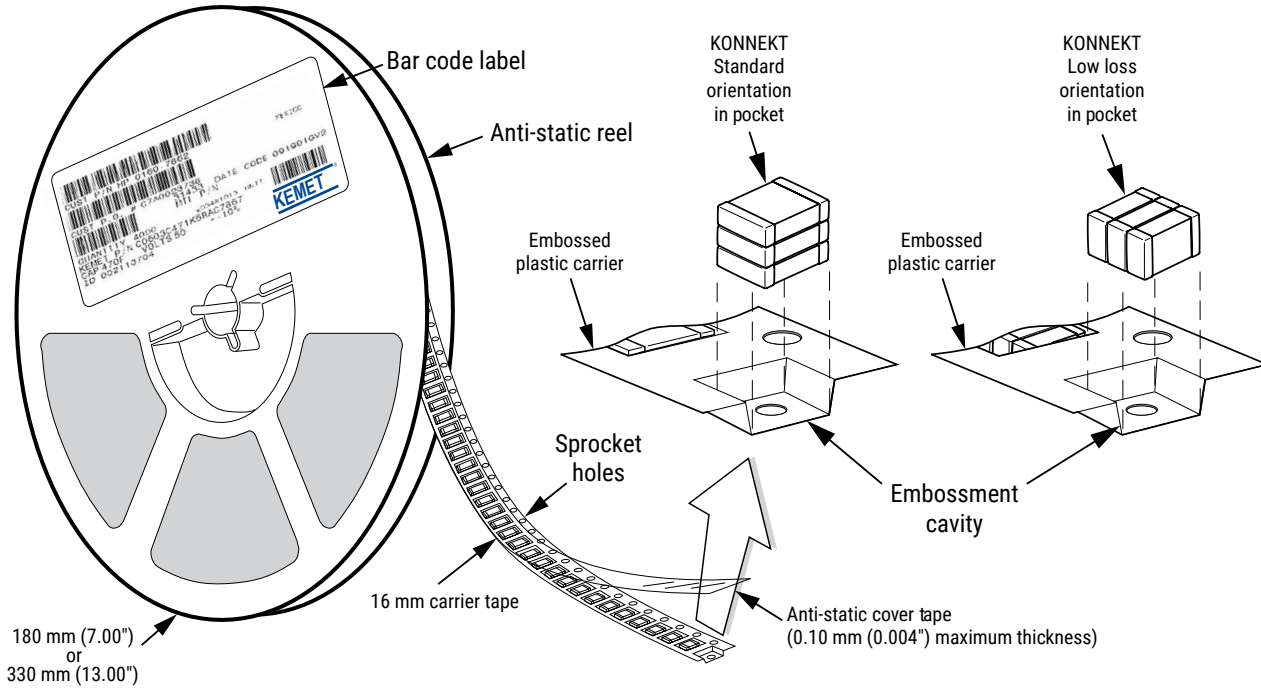

Table 4 – Carrier Tape Configuration, Embossed Plastic (mm)

EIA Case Size	Chip Number	Tape Size (W)*	Embossed Plastic	
			7" Reel	13" Reel
			Pitch (P ₁) ²	
KONNEKT 1812	2	16	8	8
	3	16	12	12

1. Refer to Figures 1 and 2 for W and P₁ carrier tape reference locations.
2. Refer to Tables 4 and 5 for tolerance specifications.

Figure 1 – Embossed (Plastic) Carrier Tape Dimensions

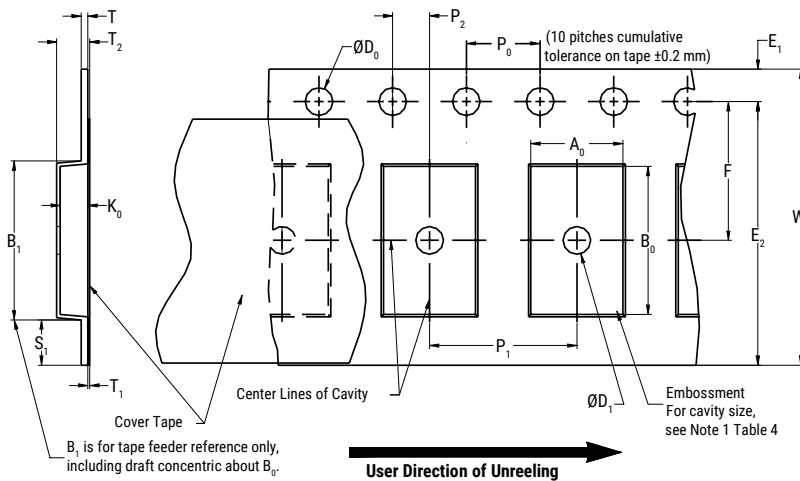

Table 5 – Embossed (Plastic) Carrier Tape Dimensions

Metric will govern

Constant Dimensions – Millimeters (Inches)									
Tape Size	D ₀	D ₁ Minimum Note 1	E ₁	P ₀	P ₂	R Reference Note 2	S ₁ Minimum Note 3	T Maximum	T ₁ Maximum
16 mm	1.5 +0.10/-0.0 (0.059 +0.004/-0.0)	1.5 (0.059)	1.75±0.10 (0.069±0.004)	4.0±0.10 (0.157±0.004)	2.0±0.05 (0.079±0.002)	30 (1.181)	0.600 (0.024)	0.600 (0.024)	0.100 (0.004)
Variable Dimensions – Millimeters (Inches)									
Tape Size	Pitch	B ₁ Maximum Note 4	E ₂ Minimum	F	P ₁	T ₂ Maximum	W Maximum	A ₀ , B ₀ & K ₀	
16 mm	Triple (12mm)	12.1 (0.476)	14.25 (0.561)	7.5±0.05 (0.138±0.002)	12.0±0.10 (0.157±0.004)	4.6 (0.181)	16.3 (0.642)	Note 5	

1. The embossment hole location shall be measured from the sprocket hole controlling the location of the embossment. Dimensions of embossment location and hole location shall be applied independent of each other.
2. The tape with or without components shall pass around R without damage (see Figure 6).
3. If S₁ < 1.0 mm, there may not be enough area for cover tape to be properly applied (see EIA Document 481 paragraph 4.3 (b)).
4. B₁ dimension is a reference dimension for tape feeder clearance only.
5. The cavity defined by A₀, B₀ and K₀ shall surround the component with sufficient clearance that:
 - (a) the component does not protrude above the top surface of the carrier tape.
 - (b) the component can be removed from the cavity in a vertical direction without mechanical restriction, after the top cover tape has been removed.
 - (c) rotation of the component is limited to 20° maximum for 8 and 12 mm tapes and 10° maximum for 16 mm tapes (see Figure 3).
 - (d) lateral movement of the component is restricted to 0.5 mm maximum for 8 mm and 12 mm wide tape and to 1.0 mm maximum for 16 mm tape (see Figure 4)
 - (e) For KPS Series product, A₀ and B₀ are measured on a plane 0.3 mm above the bottom of the pocket.
 - (f) see Addendum in EIA Document 481 for standards relating to more precise taping requirements.

Packaging Information Performance Notes

- 1. Cover Tape Break Force:** 1.0 kg minimum.
- 2. Cover Tape Peel Strength:** The total peel strength of the cover tape from the carrier tape shall be:

Tape Width	Peel Strength
16 mm	0.1 to 1.3 Newton (10 to 130 gf)

The direction of the pull shall be opposite the direction of the carrier tape travel. The pull angle of the carrier tape shall be 165° to 180° from the plane of the carrier tape. During peeling, the carrier and/or cover tape shall be pulled at a velocity of 300±10 mm/minute.

- 3. Labeling:** Bar code labeling (standard or custom) shall be on the side of the reel opposite the sprocket holes. Refer to EIA Standards 556 and 624.

Figure 2 – Maximum Component Rotation

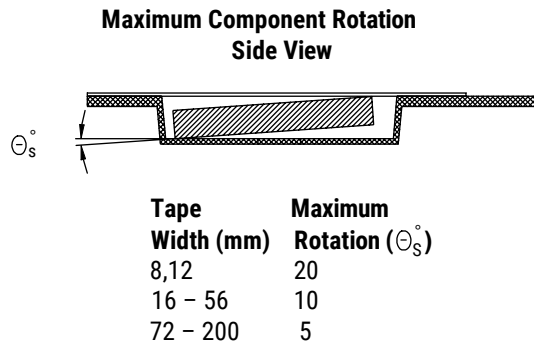
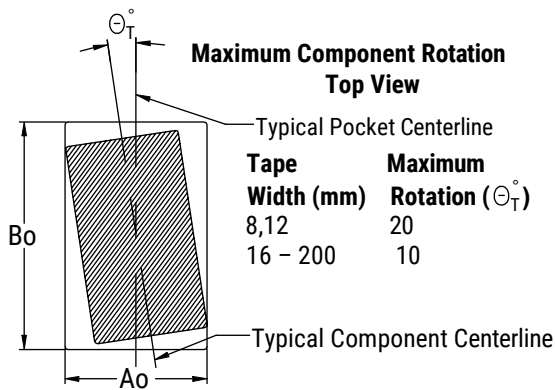

Figure 3 – Maximum Lateral Movement

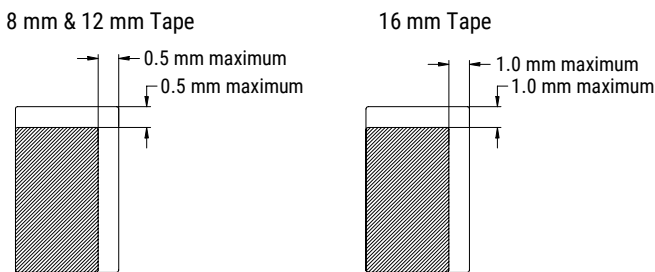

Figure 4 – Bending Radius

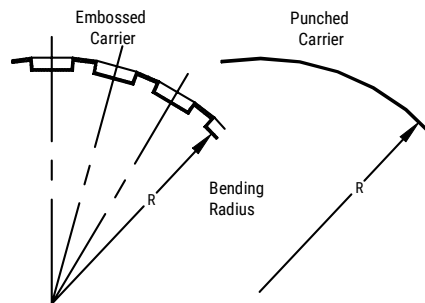
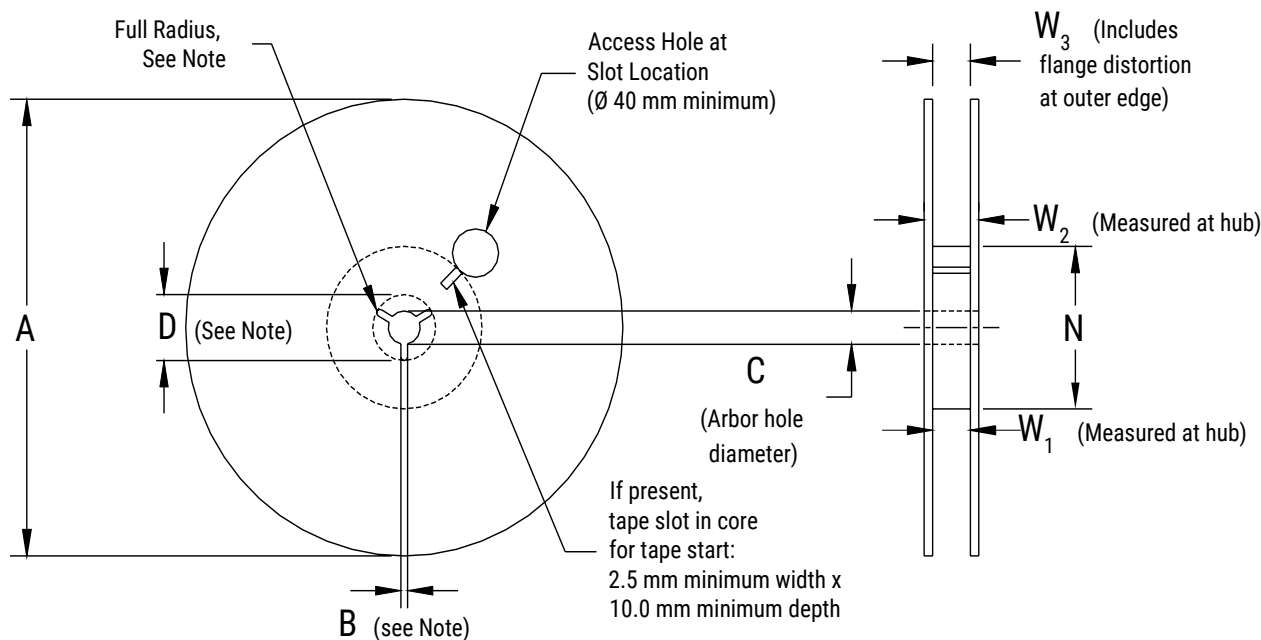

Figure 5 – Reel Dimensions



Note: Drive spokes optional; if used, dimensions B and D shall apply.

Table 6 – Reel Dimensions

Metric will govern

Constant Dimensions – Millimeters (Inches)				
Tape Size	A	B Minimum	C	D Minimum
16 mm	178±0.20 (7.008±0.008) or 330±0.20 (13.000±0.008)	1.5 (0.059)	13.0 +0.5/-0.2 (0.521 +0.02/-0.008)	20.2 (0.795)
Variable Dimensions – Millimeters (Inches)				
Tape Size	N Minimum See Note 2, Tables 2-3	W ₁	W ₂ Maximum	W ₃
16 mm	50 (1.969)	16.4 +2.0/-0.0 (0.646 +0.078/-0.0)	22.4 (0.882)	Shall accommodate tape width without interference

Figure 6 – Tape Leader & Trailer Dimensions

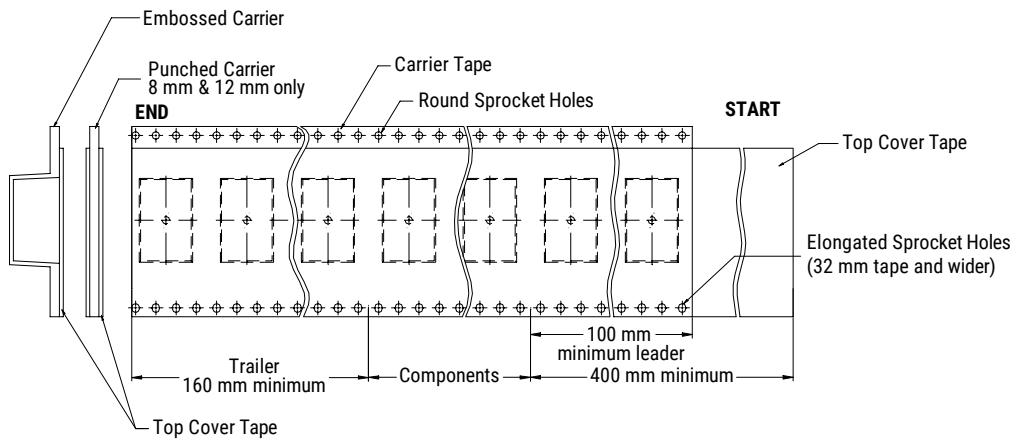
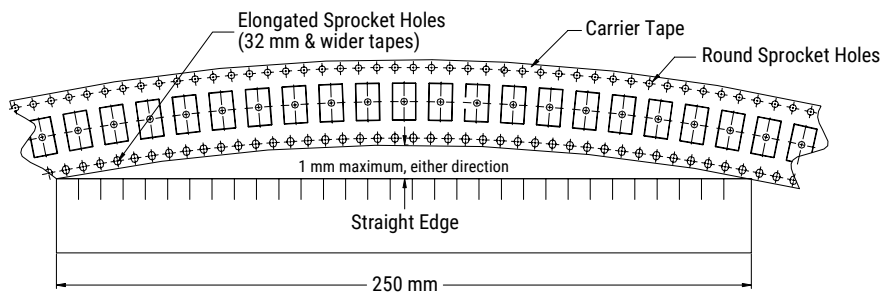

Figure 7 – Maximum Camber



KEMET Electronics Corporation Sales Offices

For a complete list of our global sales offices, please visit www.kemet.com/sales.

Disclaimer

All product specifications, statements, information and data (collectively, the "Information") in this datasheet are subject to change. The customer is responsible for checking and verifying the extent to which the Information contained in this publication is applicable to an order at the time the order is placed. All Information given herein is believed to be accurate and reliable, but it is presented without guarantee, warranty, or responsibility of any kind, expressed or implied.

Statements of suitability for certain applications are based on KEMET Electronics Corporation's ("KEMET") knowledge of typical operating conditions for such applications, but are not intended to constitute – and KEMET specifically disclaims – any warranty concerning suitability for a specific customer application or use. The Information is intended for use only by customers who have the requisite experience and capability to determine the correct products for their application. Any technical advice inferred from this Information or otherwise provided by KEMET with reference to the use of KEMET's products is given gratis, and KEMET assumes no obligation or liability for the advice given or results obtained.

Although KEMET designs and manufactures its products to the most stringent quality and safety standards, given the current state of the art, isolated component failures may still occur. Accordingly, customer applications which require a high degree of reliability or safety should employ suitable designs or other safeguards (such as installation of protective circuitry or redundancies) in order to ensure that the failure of an electrical component does not result in a risk of personal injury or property damage.

Although all product-related warnings, cautions and notes must be observed, the customer should not assume that all safety measures are indicated or that other measures may not be required.

KEMET is a registered trademark of KEMET Electronics Corporation.