



ABCIRH Connectors

Catalogue Index

General Information	Page 2
Electrical Data	3
Part Number Explanation	4
F80 Contact Arrangements.....	5
F80 Contact Arrangement Selection Chart	18
Alternative Insert Orientations.....	20
F80 Crimp Contacts - Pin	22
F80 Crimp Contacts - Socket.....	23
F80 Crimp Contacts - Low Insertion Force Socket	24
F80 Coaxial Contacts	25
F80 Twinaxial Contacts	26
Front Mounting Receptacle - ABCIRH00	27
Cable Mounted Receptacle - ABCIRH01	31
Rear Mounting Receptacle - ABCIRH03	34
Size 49 Front Mounting Receptacle - ABCIRH04	38
Size 49 Rear Mounting Receptacle - ABCIRH05	39
Plug - ABCIRH06/SE06	40
Plug, Rubber Covered Coupling Nut - ABCIRHP06.....	43
Size 49 Plug - ABCIRHP06	46
Through Bulkhead Receptacle - ABCIRH07	47
Rear Mounting Single Hole Receptacle - ABCIRH09	48
Panel Mounted Plug - ABCIRH12A	52
Conduit Adaptor With Braid Screen Trap - Type RM (CRA)	53
Non-Locking Cable Clamp - Type D (OCN)	54
Non-Locking Grommet Nut - Type EV	55
Locking 90° Outlet With Cable Clamp & Bushing - Type F.....	56
Locking 90° Outlet With Sealed Cable Clamp - Type FC.....	57
Locking 90° Outlet - Type FT	58
Locking 90° Outlet, RFI - Type FM	59
Locking Heatshrink Adaptor - Type G (HSA)	60
Locking RFI Shielded Adaptor - Type GM (LHSA)	61
Non-Locking Heatshrink Adaptor - Type GS (HSAS)	62
Locking Armoured Conduit Adaptor - Type H (ACA)	63
Locking Cable Clamp With Bushing - Type HC	64
Locking Sealed Cable Clamp - Type HD	65
Non-Locking Cable Clamp With Bushing - Type JE	66
Locking Screened Cable Adaptor - Type M (SCA)	67
Non-Locking Conduit Adaptor - Type R (CCA)	68
Non-Locking Sealed Cable Clamp - Type RC	69
Long Backshell With Cable Clamp & Bushing - Type XLA.....	70
Long Backshell With Sealed Cable Clamp - Type XLC	71
Long Backshell With Grommet - Type SHE	72
PG Threaded Adaptors (DIN 40430)	73
Cable Clamp - Type MS3057A	74
Cable Clamp - Type MS3057C	75
Telescopic Bushing	76
Panel Sealing Gaskets	77
Protective Caps	78
Wire Sealing Grommets	79
Dummy Pins, Sockets & Grommet Filler Plugs	79
Stowage Receptacles	80
Square Flange Receptacle Nut Plates	81
Square Flange Receptacles, Panel Mounting Details	82
Single Hole Mounting Receptacles, Panel Mounting Details.....	83
Contact Insertion & Extraction Tools	84
Socket Guide Pins	84
F80 Contacts, Crimp & Tooling Data	85
F80 Coax & Twinax Contacts, Crimp & Tooling Data	87



ABCIRH Connectors

General Information

Standard Data

Materials:

Connector metalwork:	Aluminium alloy
Insulator, grommet & bushing:	Low Fire Hazard, Halogen free rubber
Contacts:	Copper alloy
Accessory hardware:	Aluminium alloy

Standard Plating Finishes:

Aluminium parts:	Olive drab chromate over zinc cobalt or Olive drab chromate over cadmium plate.*
Contacts:	Silver or Gold.

* Consult factory for alternative finishes.

Operating Temperature Range:

-55°C to + 200°C

Environmental Ratings:

Shock severity:	75g
Vibration:	5-500 Hz long endurance. 30 hour test at 10g.
Acceleration:	50g.

Mechanical Features:

Coupling:	3 pin bayonet.
Number of contacts:	2 to 85
Contact termination:	Crimp.
Sealing:	Dynamic sealing ring & individual wire seal grommet. When mated and used with appropriate sealed backshell, IP67 rated.
Matings:	500 minimum

ABCIRH Connectors:

ABCIRH connectors feature stainless steel pins at critical wear points of the cam tracks of all receptacle shells, to protect from wear inflicted by continuous mating / de-mating and vibration.

Stainless Steel
Wear Pin

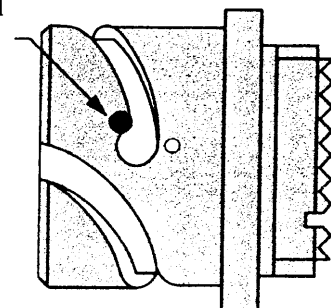

Note.

The company reserves the right and may change or vary specification without prior written notice.



ABCIRH Connectors

Electrical Data

Contact Current Ratings

Contact Size		*Maximum Current	*Rated Current	**De-rated Current
AWG	Metric	@ 20° C (68° F)	@ 85° C (185° F)	@ 85° C (185° F)
16/16S	15/15S	22A	13A	10A
12	25	41A	23A	20A
8	100	73A	46A	42A
4	160	135A	80A	75A
0	500	245A	150A	135A

* Single contact in isolation

** Grouped contacts

Contact Current De-rating Curve.

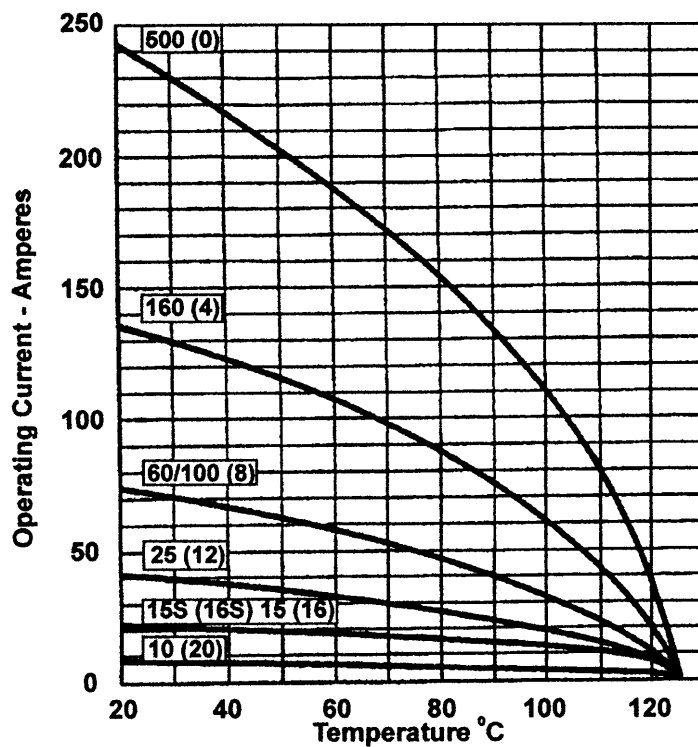

Contact Arrangement Service Ratings

Service Rating	Inst.	Sea Level		
		A	D	E
Working Voltage DC or AC Peak	350 V	700 V	1,250 V	1,750 V
Voltage Proof AC RMS	1,000 V	2,000 V	2,800 V	3,500 V
Minimum Flashover AC RMS	1,400 V	2,800 V	3,600 V	4,500 V



ABCIRH Connectors

Part Number Explanation

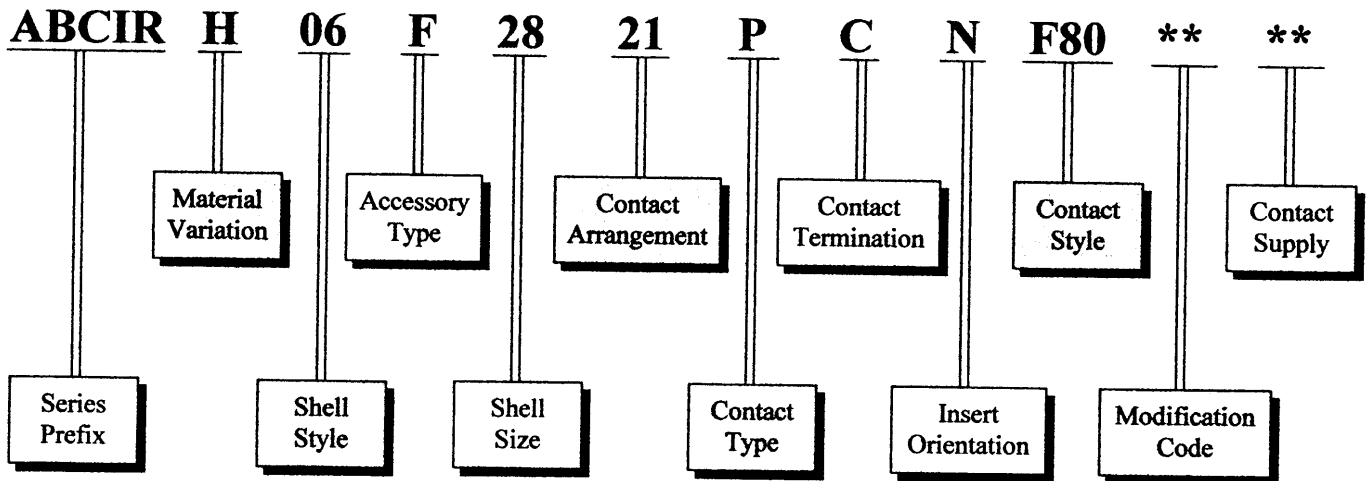

Series prefix: ABCIR

Material variation: H - Halogen Free

- Shell style:**
- 00 - Square flange receptacle, front panel mounted.
 - 01 - Cable mounted receptacle.
 - 03 - Square flange receptacle, rear panel mounted.
 - 06 - Plug. No RFI grounding.
 - P06 - Plug, rubberised coupling nut No RFI grounding.
 - SE06 - Plug with RFI grounding.
 - 07 - Through bulkhead receptacle.
 - 08 - Plug with 90° angled outlet. No RFI grounding
 - SE08 - Plug with 90° angled outlet. RFI grounding.
 - 09 - Single hole mounted receptacle.

Accessory type: See relevant catalogue pages.

Shell size: 10SL to 49 (in sixteenth of an inch).

Contact arrangement: See pages 5 to 17.

Contact type: P pin, S socket, H pin/socket assembly for bulkhead connector style 07.

Contact termination: C crimp removeable, (except bulkhead which are bonded, non-removeable, no designation).

Insert orientation: N normal. WXYZ alternative insert positions. See pages 20 & 21.

Contact style: F80

Modification code: Please consult factory.

Contact supply: Leave blank for connector supplied with silver plated contacts. Add P3 for connector supplied with standard gold plated contacts. Add V0 for connector supplied without contacts.



F80 Contact Arrangements

2 Contacts

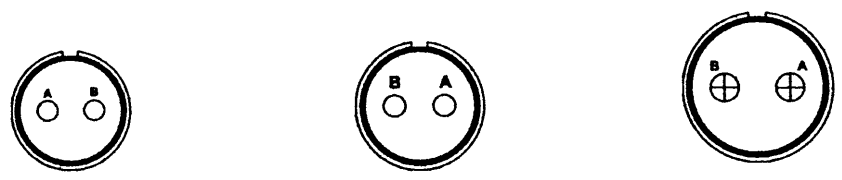

Contact Arrangement	10SL-4	14S-9	18-3
No. Contacts x Size AWG (Metric)	2 # 16S (15S)	2 # 16S (15S)	2 # 12 (25)
Service Rating	A	A	D

3 Contacts

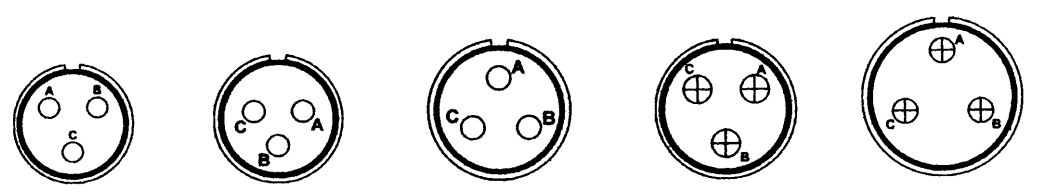

Contact Arrangement	10SL-3	14S-7	16S-5	16-10	20-3
No. Contacts x Size AWG (Metric)	3 # 16S (15S)	3 # 16S (15S)	3 # 16S (15S)	3 # 12 (25)	3 # 12 (25)
Service Rating	A	A	A	A	D

3 Contacts cont.

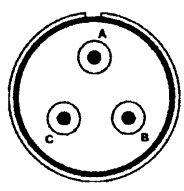

Contact Arrangement	22-2
No. Contacts x Size AWG (Metric)	3 # 8 (100)
Service Rating	D

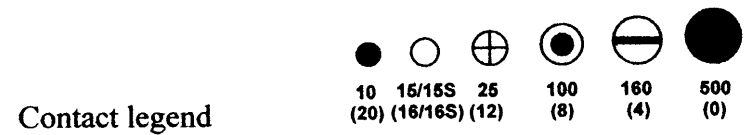

F80 Contact Arrangements

4 Contacts

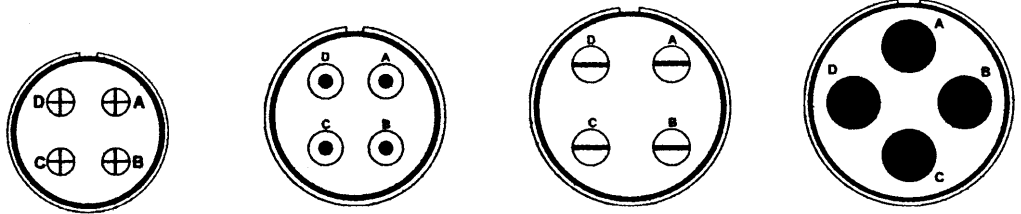

Contact Arrangement	20-4	24-22	32-17	36-5
No. Contacts x Size AWG (Metric)	4 # 12 (25)	4 # 8 (100)	4 # 4 (160)	4 # 0 (500)
Service Rating	D	D	D	A

4 Contacts cont.

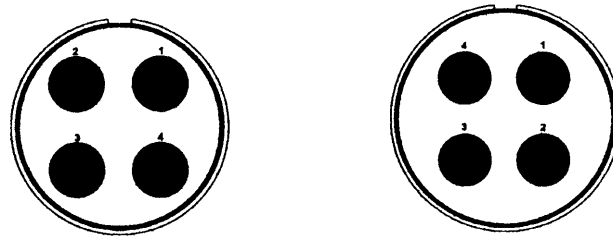

Contact Arrangement	40-E4	49-A4
No. Contacts x Size AWG (Metric)	4 # 0 (500)	4 # 0 (500)
Service Rating	E	D

5 Contacts

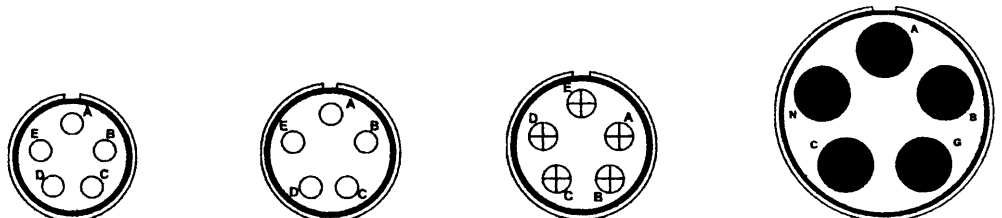

Contact Arrangement	14S-5	16S-8	18-11	40-A5
No. Contacts x Size AWG (Metric)	5 # 16S (15S)	5 # 16S (15S)	5 # 12 (25)	5 # 0 (500)
Service Rating	Inst.	A	A	A

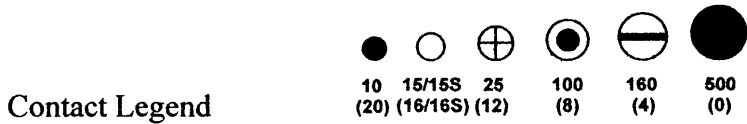

F80 Contact Arrangements

6 Contacts

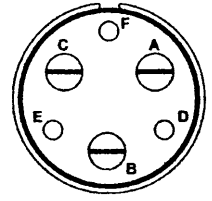
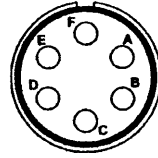
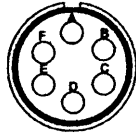

Contact Arrangement	14S-6	18-12	28-22
No. Contacts x Size AWG (Metric)	6 # 16S (15S)	6 # 16 (15)	3 # 16 (15), 3 # 4 (160)
Service Rating	Inst.	A	D

7 Contacts

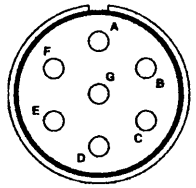
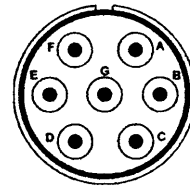
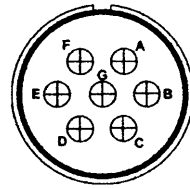
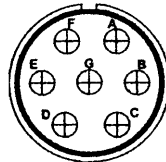
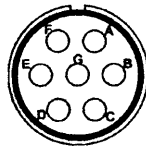

Contact Arrangement	16S-1	20-15	24-2	24-10	24-27
No. Contacts x Size AWG (Metric)	7 # 16S (15S)	7 # 12 (25)	7 # 12 (25)	7 # 8 (100)	7 # 16 (15)
Service Rating	A	A	D	A	E

8 Contacts

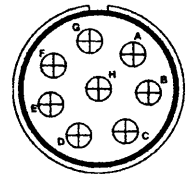
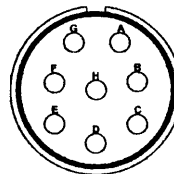
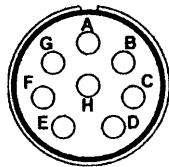

Contact Arrangement	20-7	22-18	22-23
No. Contacts x Size AWG (Metric)	8 # 16 (15)	8 # 16 (15)	8 # 12 (25)
Service Rating	A,B,H,G = D, Balance = A	A,B,F,G,H = D, Balance = A	H = D, Balance = A

Contact Legend

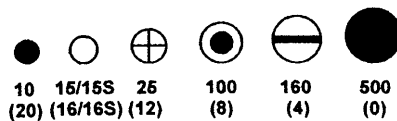

F80 Contact Arrangements

9 Contacts

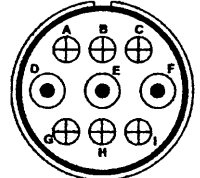
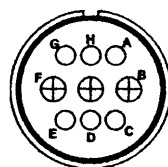
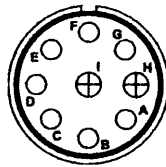
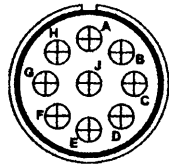

Contact Arrangement	20-A9	20-16	20-18	24-11
No. Contacts x		7 # 16 (15)	6 # 16 (15)	6 # 12 (25)
Size AWG (Metric)	9 # 12 (25)	2 # 12 (25)	3 # 12 (25)	3 # 8 (100)
Service Rating	J = D. Balance = Inst.	A	A	A

9 Contacts cont.

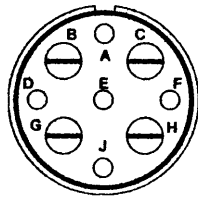

Contact Arrangement	28-A9
No. Contacts x	4 # 4 (160)
Size AWG (Metric)	5 # 16 (15)
Service Rating	A

10 Contacts

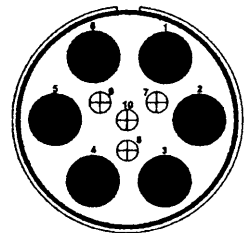
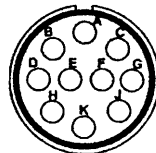
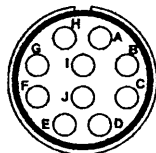

Contact Arrangement	18-1	18-19	49-A10
No. Contacts x			4 # 12 (25)
Size AWG (Metric)	10 # 16 (15)	10 # 16 (15)	6 # 0 (500)
Service Rating	B,C,F,G = A. Balance = Inst.	A	D

Contact Legend

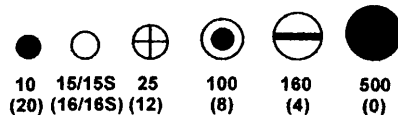



F80 Contact Arrangements

11 Contacts

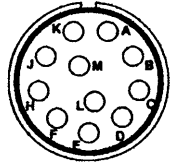

Contact Arrangement	20-33
No. Contacts x	
Size AWG (Metric)	11 # 16 (15)
Service Rating	A

12 Contacts

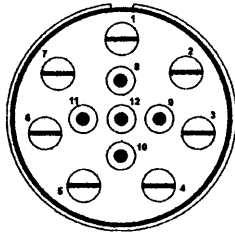

Contact Arrangement	49-A12
No. Contacts x	5 # 8 (100)
Size AWG (Metric)	7 # 4 (160)
Service Rating	D

13 Contacts

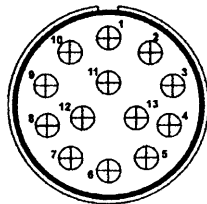

Contact Arrangement	32-A13
No. Contacts x	
Size AWG (Metric)	13 # 12 (25)
Service Rating	D

Contact Legend

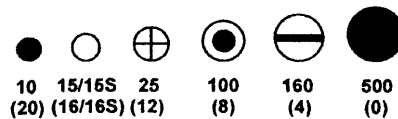

F80 Contact Arrangements

14 Contacts

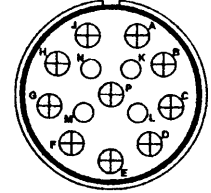
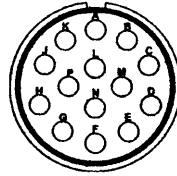
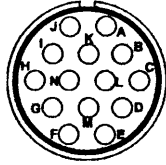

Contact Arrangement	20-27	22-19	28-20
No. Contacts x			4 # 16 (15)
Size AWG (Metric)	14 # 16 (15)	14 # 16 (15)	10 # 12 (25)
Service Rating	A	A	A

16 Contacts

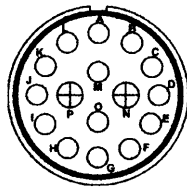

Contact Arrangement	24-7
No. Contacts x	14 # 16 (15)
Size AWG (Metric)	2 # 12 (25)
Service Rating	A

17 Contacts

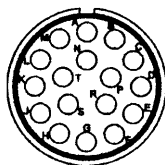

Contact Arrangement	20-29
No. Contacts x	
Size AWG (Metric)	17 # 16 (15)
Service Rating	A

Contact Legend

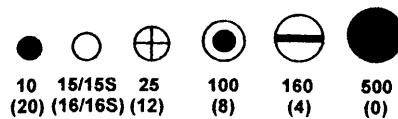

F80 Contact Arrangements

19 Contacts

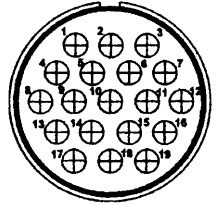
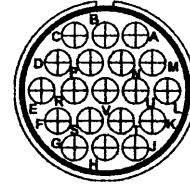
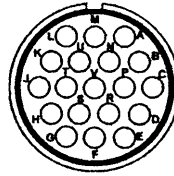
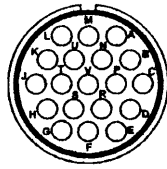

Contact Arrangement	20-A48	22-14	24-67	32-76
No. Contacts x				
Size AWG (Metric)	19 # 16 (15)	19 # 16 (15)	19 # 12 (25)	19 # 12 (25)
Service Rating	Inst.	A	A	A

20 Contacts

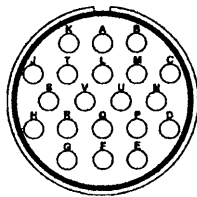

Contact Arrangement	28-16
No. Contacts x	
Size AWG (Metric)	20 # 16 (15)
Service Rating	A

21 Contacts

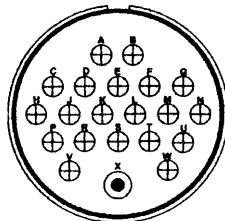

Contact Arrangement	40-D21
No. Contacts x	20 # 12 (25)
Size AWG (Metric)	1 # 8 (100)
Service Rating	D

Contact Legend

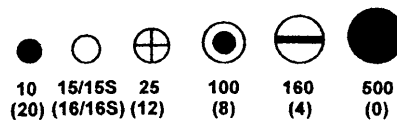

F80 Contact Arrangements

22 Contacts

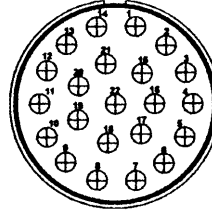
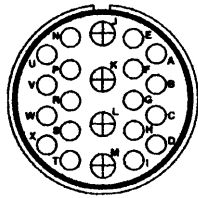

Contact Arrangement	28-11	36-A22
No. Contacts x	18 # 16 (15)	
Size AWG (Metric)	4 # 12 (25)	22 # 12 (25)
Service Rating	A	D

24 Contacts

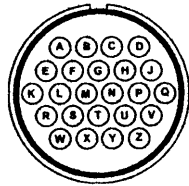

Contact Arrangement	24-28
No. Contacts x	
Size AWG (Metric)	24 # 16 (15)
Service Rating	Inst.

25 Contacts



Contact Arrangement	24-A25
No. Contacts x	
Size AWG (Metric)	25 # 16 (15)
Service Rating	A

Contact Legend

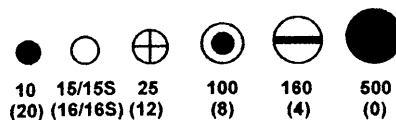

F80 Contact Arrangements

26 Contacts

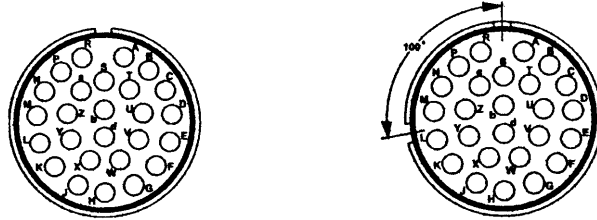

Contact Arrangement	28-12	28-13
No. Contacts x Size AWG (Metric)	26 # 16 (15)	28-12 Rotated by 100° 26 # 16 (15)
Service Rating	A	A

31 Contacts

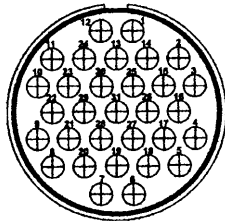

Contact Arrangement	40-A31
No. Contacts x Size AWG (Metric)	31 # 12 (25)
Service Rating	D

32 Contacts

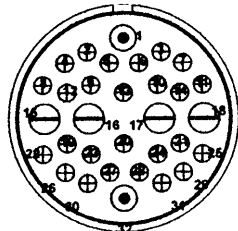

Contact Arrangement	49-D32
No. Contacts x Size AWG (Metric)	26 # 12 (25), 2 # 8 (100) 4 # 4 Coax
Service Rating	D

Contact Legend

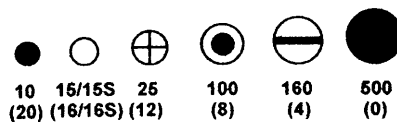

F80 Contact Arrangements

35 Contacts

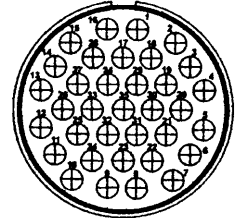
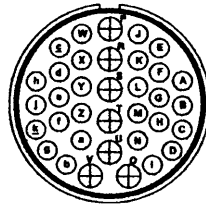
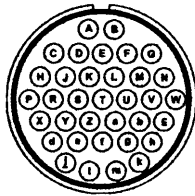

Contact Arrangement	28-15	32-7	40-A35
No. Contacts x			
Size AWG (Metric)	35 # 16 (15)	28 # 16 (15), 7 # 12 (25)	35 # 12 (25)
Service Rating	A	A,B,h & j = Inst. Balance = A	D

37 Contacts

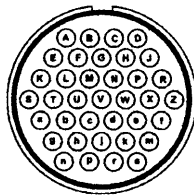

Contact Arrangement	28-21
No. Contacts x	
Size AWG (Metric)	37 # 16 (15)
Service Rating	A

38 Contacts

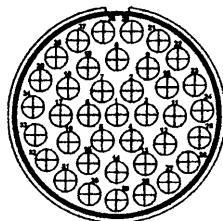

Contact Arrangement	40-A38
No. Contacts x	
Size AWG (Metric)	38 # 12 (25)
Service Rating	A

Contact Legend

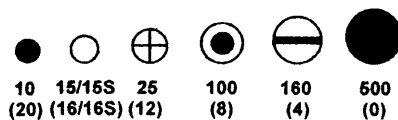

F80 Contact Arrangements

39 Contacts

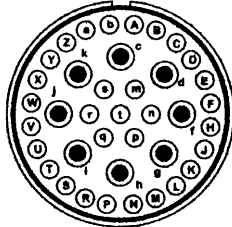

Contact Arrangement	36-54
No. Contacts x	
Size AWG (Metric)	31 # 16 (15), 8 # 8 (100)
Service Rating	A

47 Contacts

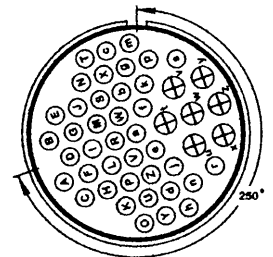
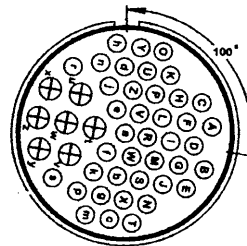
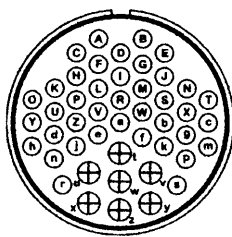

Contact Arrangement	36-7	36-16	36-17
No. Contacts x			
Size AWG (Metric)	40 # 16 (15), 7 # 12 (25)	36-7 Rotated by 100°	36-7 Rotated by 250°
Service Rating	A	A	A

48 Contacts

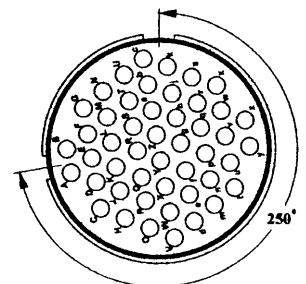
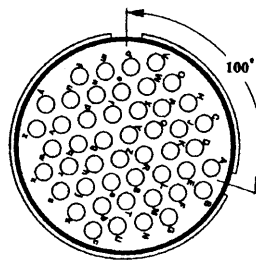
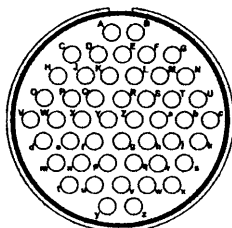

Contact Arrangement	36-10	36-11	36-12
No. Contacts x			
Size AWG (Metric)	48 # 16 (15)	36-10 Rotated by 100°	36-10 Rotated by 250°
Service Rating	A	A	A

Contact Legend

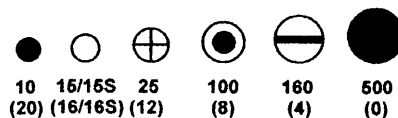

F80 Contact Arrangements

48 Contacts cont.

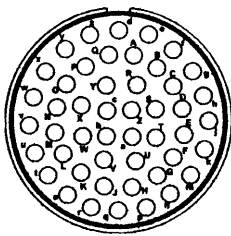

Contact Arrangement	36-A48
No. Contacts x	48 # 16 (15)
Size AWG (Metric)	48 # 16 (15)
Service Rating	Inst.

49 Contacts

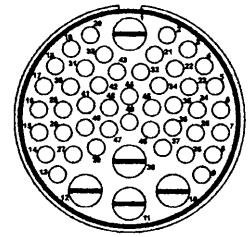
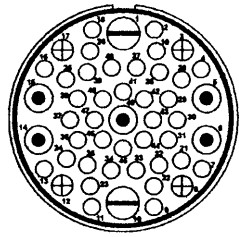

Contact Arrangement	49-A49	49-D1
No. Contacts x	38 # 16 (15), 4 # 12 (25)	44 # 16 (15)
Size AWG (Metric)	5 # 8 (100), 2 # 4 (160)	5 # 4 (160)
Service Rating	D	D

54 Contacts

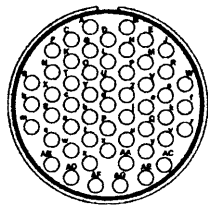

Contact Arrangement	32-22
No. Contacts x	54 # 16 (15)
Size AWG (Metric)	54 # 16 (15)
Service Rating	A

Contact Legend

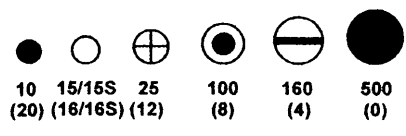



F80 Contact Arrangements

55 Contacts

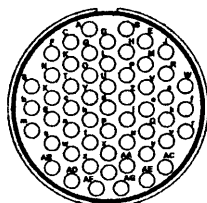

Contact Arrangement	32-A55
No. Contacts x Size AWG (Metric)	55 # 16 (15)
Service Rating	A

60 Contacts

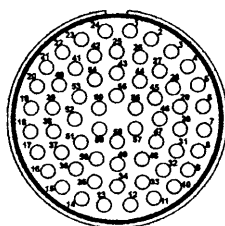

Contact Arrangement	40-A60
No. Contacts x Size AWG (Metric)	60 # 16 (15)
Service Rating	A

85 Contacts

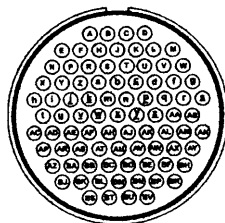

Contact Arrangement	40-56
No. Contacts x Size AWG (Metric)	85 # 16 (15)
Service Rating	A

Contact Legend

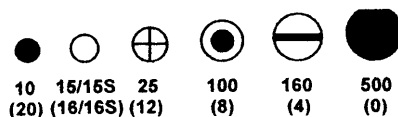



F80 Contact Arrangements

Selection Chart

Contact Size AWG(Metric) & Current Rating (Derated)											
Amps at 85° C											
Shell Size	Cont. Arr.	No. of Cts.	20 (10)	16/16S (15/15S)	12 (25)	8 (100)	4 (160)	0 (500)	0000	Shell Orient	Serv. Rating
10SL	3	3		3x10A						N	A
10SL	4	2		2x10A						N	A
14S	5	5		5x10A						NX	Inst.
14S	6	6		6x10A						NW	Inst.
14S	7	3		3x10A						NWXY	A
14S	9	2		2x10A						NWXYZ	A
16S	1	7		7x10A						NWZ	A
16S	5	3		3x10A						NWXYZ	A
16S	8	5		5x10A						NXY	A
16	10	3			3x20A					NWXY	A
18	1	10		10x10A						NWXYZ	*A&Inst
18	3	2			2x20A					NWXYZ	D
18	11	5			5x20A					NXY	A
18	12	6		6x10A						NWZ	A
18	19	10		10x10A						NXY	A
20	3	3			3x20A					NWXYZ	D
20	4	4			4x20A					NWXY	D
20	7	8		8x10A						NWXYZ	*A&D
20	A9	9			9x20A					NXY	*D&Inst
20	15	7			7x20A					NWZ	A
20	16	9		7x10A	2x20A					NWXYZ	A
20	18	9		6x10A	3x20A					NWXYZ	A
20	27	14		14x10A						NWXYZ	A
20	29	17		17x10A						NWZ	A
20	33	11		11x10A						NZ	A
20	A48	19		19x10A						NXY	Inst
22	2	3				3x42A				NWXYZ	D
22	14	19		19x10A						NWZ	A
22	18	8		8x10A						NWXYZ	*A&D
22	19	14		14x10A						NWXYZ	A
22	23	8			8x20A					NWY	*A&D
24	2	7			7x20A					NWZ	D
24	7	16		14x10A	2x20A					NWXYZ	A
24	10	7				7x42A				NWZ	A
24	11	9			6x20A	3x42A				NWXYZ	A
24	22	4				4x42A				NWXY	D
24	27	7		7x10A						NWZ	E
24	28	24		24x10A						NWXYZ	Inst.
24	67	19			19x20A					NWZ	A
24	A25	25		25x10A						NWXYZ	A

*Contact Arrangements/Service Ratings

18-1 Contacts B,C,F,G = A.

Balance = Inst.

20-A9 Contact J = D

Balance = Inst.

20-7 Contacts C,D,E,F = A

Balance = D

22-18 Contacts A,B,F,G,H = D

Balance = A

22-23 Contact H = D

Balance = A



F80 Contact Arrangements Selection Chart cont.

Contact Size AWG(Metric) & Current Rating (Derated) Amps at 85° C											
Shell Size	Cont. Arr.	No. of Cts.	20 (10)	16/16S (15/15S)	12 (25)	8 (60/100)	4 (160)	0 (500)	0000	Shell Orient	Serv. Rating
28	11	22		18x10A	4x20A					NWXYZ	A
28	12	26		26x10A						NWXY	A
28	13	26		26x10A						-	A
28	15	35		35x10A						NWXYZ	A
28	16	20		20x10A						NWXYZ	A
28	20	14		4x10A	10x20A					NWXYZ	A
28	21	37		37x10A						NWXYZ	A
28	22	6		3x10A			3x75A			NWXYZ	D
28	A9	9		5X10A			4X75A			NWXYZ	A
32	7	35		28x10A	7x20A					NWXYZ	*A&Inst
32	17	4					4x75A			NWXY	D
32	22	54		54x10A						NWXYZ	A
32	76	19			19x20A					NWXYZ	A
32	A13	13			13x20A					NWXYZ	D
32	A55	55		55x10A						NWXYZ	A
36	5	4						4x135A		NXY	A
36	7	47		40x10A	7x20A					NWXYZ	A
36	10	48		48x10A						NWXYZ	A
36	11	48		48x10A						-	A
36	12	48		48x10A						-	A
36	16	47		40x10A	7x20A					-	A
36	17	47		40x10A	7x20A					-	A
36	A22	22			22x20A					NWXYZ	D
36	A48	48		48x10A						NW	Inst
36	54	39		31x10A		8x42A				NW	A
40	56	85		85x10A						NWXYZ	A
40	A5	5						5x135A		NWZ	A
40	A31	31			31x20A					NWXYZ	D
40	A35	35			35x20A					NWXYZ	D
40	A38	38			38x20A					NWXYZ	A
40	A60	60		60x10A						NWXYZ	A
40	E4	4						4x135A		NWX	E
40	D21	21			20x20A	1x42A				NW	D
49	A4	4						4x135 A		N	D
49	A10	10			4x20A			6x135A		N	D
49	A12	12				5x42A	7x75A			N	D
49	D32	32			26x20A	2x42A	4xCoax			N	D
49	A49	49		38x10A	4x20A	5x42A	2x75A			N	D
49	D1	49		44x10A			5x75A			N	D

*Contact Arrangements/Service Ratings
32-7 Contacts A,B,H,J = Inst Balance = A

Alternative Insert Orientations

View on Mating Face of Pin Inserts

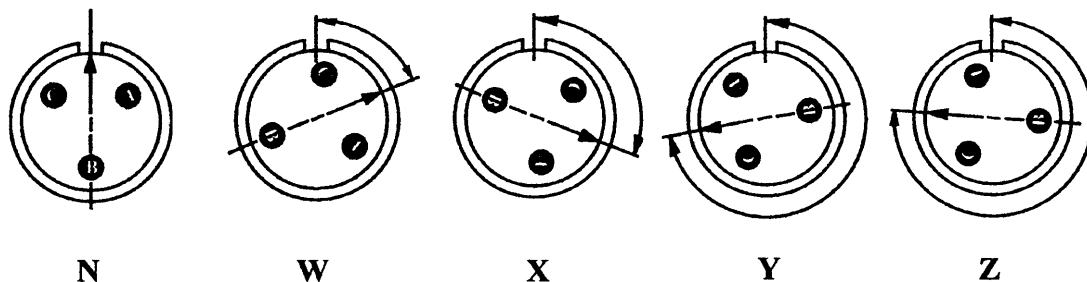

Contact Arrangement	Angular Displacement Of Insert				
	N Yellow	W Blue	X Green	Y Purple	Z White
10SL-3	0	-	-	-	-
10SL-4	0	-	-	-	-
14S-5	0	-	110	-	-
14S-6	0	90	-	-	-
14S-7	0	90	180	270	-
14S-9	0	70	145	215	290
16S-1	0	80	-	-	280
16S-5	0	70	145	215	290
16S-8	0	-	170	265	-
16-10	0	90	180	270	-
18-1	0	70	145	215	290
18-3	0	35	110	250	325
18-11	0	-	170	265	-
18-12	0	80	-	-	280
18-19	0	-	120	240	-
20-3	0	70	145	215	290
20-4	0	45	110	250	-
20-7	0	80	110	250	280
20-A9	0	-	110	250	-
20-15	0	80	-	-	280
20-16	0	80	110	250	280
20-18	0	35	110	250	325
20-27	0	35	110	250	325
20-29	0	80	-	-	280
20-33	0	-	-	-	280
20-A48	0	-	80	280	-
22-2	0	70	145	215	290
22-14	0	80	-	-	280
22-18	0	80	110	250	280
22-19	0	80	110	250	280
22-23	0	35	-	250	-
24-2	0	80	-	-	280
24-7	0	80	110	250	280
24-10	0	80	-	-	280
24-11	0	35	110	250	325
24-22	0	45	110	250	-
24-27	0	80	-	-	280
24-28	0	80	110	250	280
24-67	0	80	-	-	335
24-A25	0	80	110	250	280

Alternative Insert Orientations

View on Mating Face of Pin Inserts

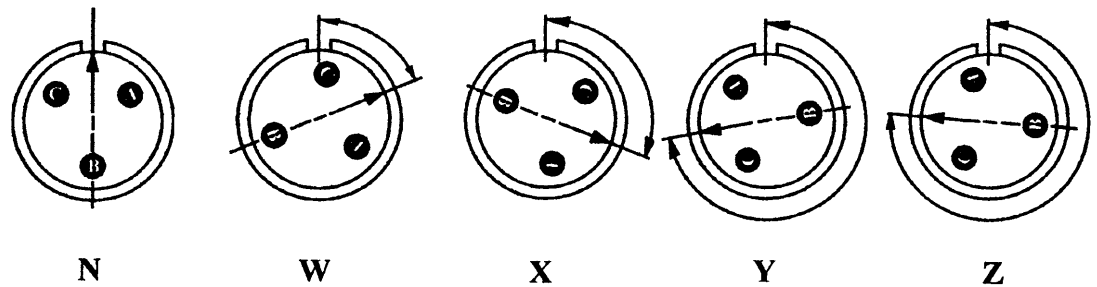

Contact Arrangement	Angular Displacement Of Insert				
	N Yellow	W Blue	X Green	Y Purple	Z White
28-11	0	80	110	250	280
28-12	0	90	180	270	-
28-13	0	-	-	-	-
28-15	0	80	110	250	280
28-16	0	80	110	250	280
28-20	0	80	110	250	280
28-21	0	80	110	250	280
28-22	0	70	145	215	290
28-A9	0	110	250	260	280
32-7	0	80	125	235	280
32-17	0	45	110	250	-
32-22	0	80	110	250	280
32-76	0	80	110	250	280
32-A13	0	65	130	230	295
32-A55	0	80	110	250	280
36-5	0	-	120	240	-
36-7	0	80	110	250	280
36-10	0	80	125	235	280
36-11	0	-	-	-	-
36-12	0	-	-	-	-
36-16	0	-	-	-	-
36-17	0	-	-	-	-
36-A22	0	80	110	250	280
36A48	0	65	-	-	-
36-54	0	67	-	-	-
40-56	0	72	144	216	288
40-A5	0	33	-	-	270
40-A31	0	80	110	250	280
40-A35	0	70	130	230	290
40-A38	0	37	74	285	322
40-A60	0	80	110	250	280
40-E4	0	45	110	-	-
40-D21	0	80	-	-	-
49-A4	0	-	-	-	-
49-A10	0	-	-	-	-
49-A12	0	-	-	-	-
49-D32	0	-	-	-	-
49-A49	0	-	-	-	-
49-D1	0	-	-	-	-

F80 Crimp Contacts

Pin

Metric
Imperial

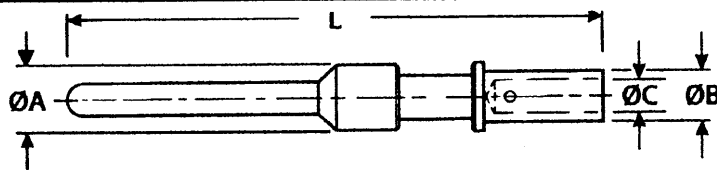

Contact Size AWG (Metric)	Part Number	A	B	C	Conductor CSA mm ²	L
16S/20	ABB16S/20KPKF80	3,20 0.126	2,65 0.104	1,10 0.043	0,50/0,75	26,60 1.047
16S/18	ABB16S/18KPKF80	3,20 0.126	2,30 0.091	1,25 0.049	0,75/0,93	26,60 1.047
16S (15S)	ABB16SKPKF80	3,20 0.126	2,75 0.108	1,75 0.069	0,93/1,50	26,60 1.047
16S/14	ABB16S/14KPKF80	3,20 0.126	2,90 0.114	1,80 0.071	1,94/2,08	26,60 1.047
16/22	ABB16/22KPKF80	3,20 0.126	2,30 0.091	0,90 0.035	0,22/0,34	31,75 1.250
16/20	ABB16/20KPKF80	3,20 0.126	2,65 0.104	1,10 0.043	0,50/0,75	31,75 1.250
16/18	ABB16/18KPKF80	3,20 0.126	2,30 0.091	1,25 0.049	0,75/0,93	31,75 1.250
16 (15)	ABB16KPKF80	3,20 0.126	2,75 0.108	1,75 0.069	0,93/1,50	31,75 1.250
16/14	ABB16/14KPKF80	3,20 0.126	2,90 0.114	1,80 0.071	1,94/2,08	31,75 1.250
16/12	ABB16/12KPKF80	3,20 0.126	3,80 0.150	2,50 0.098	2,50/3,00	31,75 1.250
12/20	ABB12/20KPKF80	4,80 0.189	2,65 0.104	1,10 0.043	0,50/0,75	37,50 1.476
12/18	ABB12/18KPKF80	4,80 0.189	2,30 0.091	1,25 0.049	0,75/0,93	37,50 1.476
12/16 (25/15)	ABB12/16KPKF80	4,80 0.189	2,75 0.108	1,75 0.069	0,93/1,50	37,50 1.476
12/14	ABB12/14KPKF80	4,80 0.189	2,90 0.114	1,80 0.071	1,94/2,08	37,50 1.476
12 (25)	ABB12KPKF80	4,80 0.189	3,80 0.150	2,50 0.098	2,50/3,00	37,50 1.476
12/10	ABB12/10KPKF80	4,80 0.189	4,40 0.173	3,00 0.118	5,53	37,50 1.476
12/40 (25/40)	ABB12/40KPKF80	4,80 0.189	4,00 0.157	2,70 0.106	4,00	37,50 1.476
8/40 (100/40)	ABB8/40KPKF80	7,80 0.307	5,20 0.205	2,90 0.114	4,00	40,70 1.602
8/12	ABB8/12KPKF80	7,80 0.307	3,80 0.150	2,50 0.098	2,50	40,70 1.602
8/10	ABB8/10KPKF80	7,80 0.307	5,20 0.205	3,30 0.130	5,53	40,70 1.602
8	ABB8KPKF80	7,80 0.307	6,80 0.268	4,55 0.179	9,00	40,70 1.602
(100/60)	ABB100/60KPKF80	7,80 0.307	5,50 0.217	3,40 0.134	6,00	40,70 1.602
(100)	ABB100KPKF80	7,80 0.307	7,00 0.276	4,40 0.173	10,00	40,70 1.602
4/10	ABB4/10KPKF80	11,00 0.433	5,20 0.205	3,30 0.130	553	41,25 1.624
4	ABB4KPKF80	11,00 0.433	9,55 0.376	7,10 0.280	22,00	41,25 1.624
(160)	ABB160KPKF80	11,00 0.433	9,45 0.372	5,70 0.224	16,00	41,25 1.624
0	ABB0KPKF80	15,00 0.591	14,35 0.565	11,50 0.453	53,0	44,50 1.752
(500/160)	ABB500/160KPKF80	15,00 0.591	9,45 0.372	5,70 0.224	16,00	44,50 1.752
(500/250)	ABB500/250KPKF80	15,00 0.591	10,00 0.394	7,00 0.276	25,00	44,50 1.752
(500/350)	ABB500/350KPKF80	15,00 0.591	11,90 0.468	8,00 0.315	35,00	44,50 1.752
(500)	ABB500KPKF80	15,00 0.591	14,35 0.565	9,80 0.386	50,00	44,50 1.752

For standard gold plating, add P3 to the end of the part number.

F80 Crimp Contacts

Socket

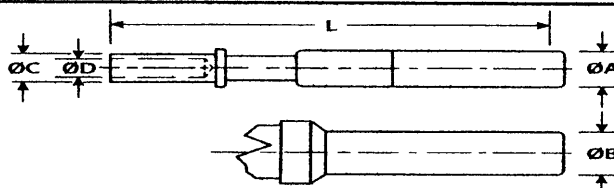

Metric
Imperial

Contact Size AWG (Metric)	Part Number	A	B	C	D	Conductor CSA mm ²	L
16S/20	ABB16S/20KSKF80	3,20	-	2,65	1,10	0,50/0,75	26,60
		0.126		0.104	0.049		1.047
16S/18	ABB16S/18KSKF80	3,20	-	2,30	1,25	0,75/0,93	26,60
		0.126		0.091	0.069		1.047
16S (15S)	ABB16SKSKF80	3,20	-	2,75	1,75	0,93/1,50	26,60
		0.126		0.108	0.069		1.047
16S/14	ABB16S/14KSKF80	3,20	-	3,90	1,80	1,94/2,08	26,60
		0.126		0.114	0.071		1.047
16/22	ABB16/22KSKF80	3,20	-	2,30	0,90	0,22/0,34	36,50
		0.126		0.091	0.035		1.437
16/20	ABB16/20KSKF80	3,20	-	2,65	1,10	0,50/0,75	36,50
		0.126		0.104	0.049		1.437
16/18	ABB16/18KSKF80	3,20	-	2,30	1,25	0,75/0,93	36,50
		0.126		0.091	0.049		1.437
16 (15)	ABB16KSKF80	3,20	-	2,75	1,75	0,93/1,50	36,50
		0.126		0.108	0.07		1.437
16/14	ABB16/14KSKF80	3,20	-	2,90	1,80	1,94/2,08	36,50
		0.126		0.114	0.071		1.437
16/12	ABB16/12KSKF80	3,20	-	3,80	2,50	2,50/3,00	36,50
		0.126		0.150	0.098		1.476
12/20	ABB12/20KSKF80	4,80	-	2,65	1,10	0,50/0,75	37,50
		0.189		0.104	0.049		1.476
12/18	ABB12/18KSKF80	4,80	-	2,30	1,25	0,75/0,93	37,50
		0.189		0.091	0.049		1.476
12/16 (25/15)	ABB12/16KSKF80	4,80	-	2,75	1,75	0,93/1,50	37,50
		0.189		0.108	0.069		1.476
12/14	ABB12/14KSKF80	4,80	-	2,90	1,80	1,94/2,08	37,50
		0.189		0.114	0.071		1.476
12 (25)	ABB12KSKF80	4,80	-	3,80	2,50	2,50/3,00	37,50
		0.189		0.150	0.098		1.476
12/10	ABB12/10KSKF80	480	-	4,40	3,00	5,53	37,50
		0.189		0.173	0.118		1.476
12/40 (25/40)	ABB12/40KSKF80	4,80	-	4,00	2,70	4,00	37,50
		0.189		0.157	0.106		1.476
8/40	ABB8/40KSKF80	7,80	6,50	5,20	2,90	4,00	40,70
		0.307	0.256	0.204	0.114		1.602
8/12	ABB8/12KSKF80	7,80	4,80	3,80	2,50	2,50/3,00	40,70
		0.307	0.189	0.150	0.098		1.602
8/10	ABB8/10KSKF80	7,80	6,50	4,40	3,00	5,53	40,70
		0.307	0.256	0.173	0.118		1.602
8	ABB8KSKF80	7,80	6,50	6,80	4,55	9,00	40,70
		0.307	0.256	0.268	0.179		1.602
(100/60)	ABB100/60KSKF80	7,80	6,50	5,50	3,40	6,00	40,70
		0.307	0.256	0.217	0.134		1.602
(100)	ABB100KSKF80	7,80	6,50	7,00	4,40	10,00	40,70
		0.307	0.256	0.276	0.173		1.602
4/10	ABB4/10KSKF80	11,10	6,50	5,20	3,30	5,53	41,25
		0.437	0.256	0.205	0.130		1.624
4	ABB4KSKF80	11,10	8,60	9,55	7,10	22,00	41,25
		0.437	0.339	0.376	0.280		1.624
(160)	ABB160KSKF80	11,10	8,60	9,45	5,70	16,00	41,25
		0.437	0.339	0.372	0.224		1.624
0	ABB0KSKF80	15,10	13,20	14,35	11,50	53,00	44,50
		0.594	0.520	0.565	0.453		1.752
(500/160)	ABB500/160KSKF80	15,10	13,20	9,45	5,70	16,00	44,50
		0.594	0.520	0.372	0.224		1.752
(500/250)	ABB500/250KSKF80	15,10	13,20	10,00	7,00	25,00	44,50
		0.594	0.520	0.394	0.276		1.752
(500/350)	ABB500/350KPKF80	15,10	13,20	11,90	8,00	35,00	44,50
		0.594	0.520	0.469	0.315		1.752
(500)	ABB500KPKF80	15,10	13,20	14,35	9,80	50,00	44,50
		0.594	0.520	0.565	0.386		1.752

For standard gold plating, add P3 to the end of the part number.

F80 Crimp Contacts

Low Insertion Force Socket

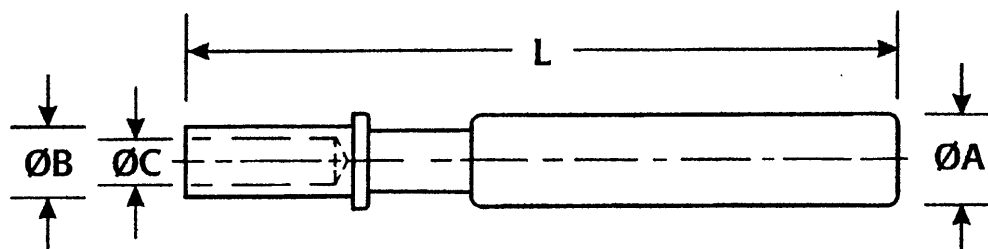

Metric
Imperial

Contact Size AWG (Metric)	Part Number	A	B	C	Conductor CSA mm ²	L
16S (15S)	ABB16SKLKF80P3	3,20 0.126	2,75 0.108	1,75 0.069	1,00/1,50	26,60 1.047
16/20	ABB16/20KLKF80P3	3,20 0.126	2,65 0.104	1,10 0.043	0,50/0,75	36,50 1.437
16 (15)	ABB16KLKF80P3	3,20 0.126	2,75 0.108	1,75 0.069	1,00/1,50	36,50 1.437
12/20	ABB12/20KLKF80P3	4,80 0.189	2,65 0.104	1,10 0.043	0,50/0,75	37,50 1.476
12/16 (25/15)	ABB12/16KLKF80P3	4,80 0.189	2,75 0.108	1,75 0.069	1,00/1,50	37,50 1.476
12 (25)	ABB12KLKF80P3	4,80 0.189	3,80 0.150	2,50 0.098	2,50/3,00	37,50 1.476

Standard gold plated contacts.



F80 Crimp Contacts

Coaxial Pin & Socket

Pin Contact

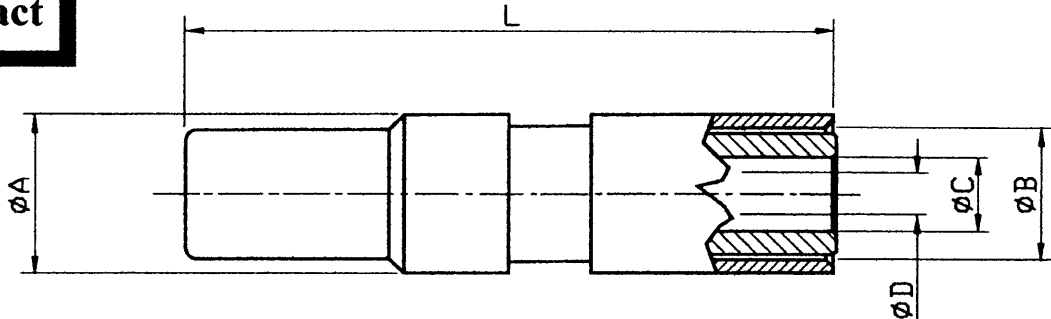

Metric
Imperial

Contact Size AWG	Part Number	A	B	C	D	L	Use With Conductors
4	ABB 4 CKPK F80 P1 001	11,10 0.437	9,80 0.386	5,20 0.205	1,07 0.042	44,70 1.760	0.5 mm ²
4	ABB 4 CKPK F80 P1 002	11,10 0.437	9,80 0.386	7,50 0.295	1,75 0.069	44,70 1.760	1.0 mm ²

Socket Contact

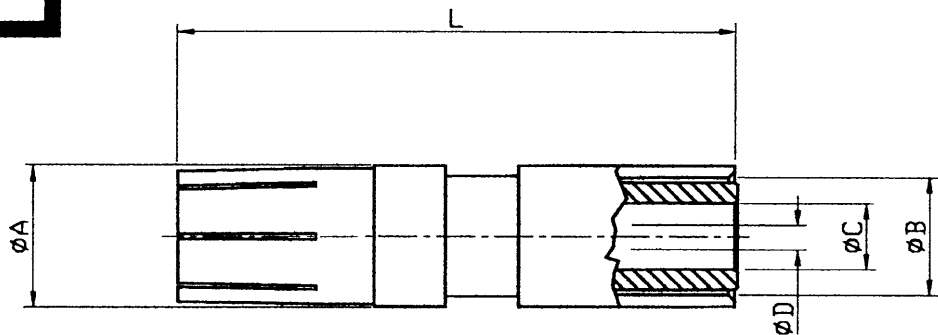

Metric
Imperial

Contact Size AWG*	Part Number	A	B	C	D	L	Use With Conductors
4	ABB 4 CKSK F80 P1 001	11,10 0.437	9,80 0.386	5,20 0.205	1,07 0.042	43,05 1.695	0.5 mm ²
4	ABB 4 CKSK F80 P1 002	11,10 0.437	9,80 0.386	7,50 0.295	1,75 0.069	43,05 1.695	1.0 mm ²

* Consult factory for contact arrangement details

F80 Crimp Contacts

Twinaxial Pin & Socket

Pin Contact

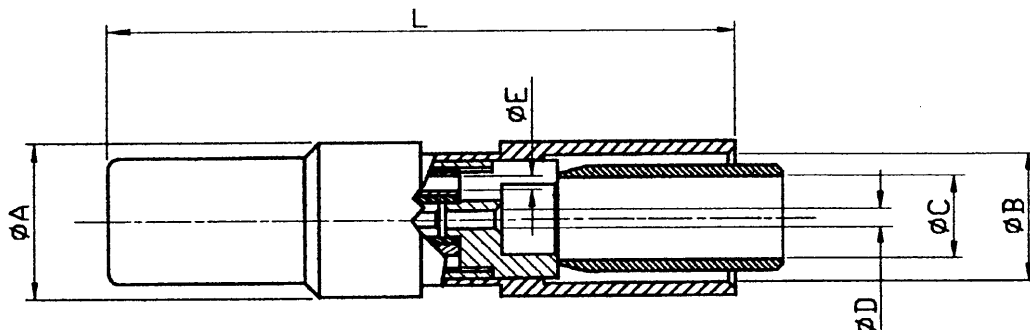

Metric
Imperial

Contact Size AWG	Part Number	A	B	C	D	E	L	Use With Conductors
4	ABB 4 TKPK F80 P1	11,10	9,80	6,00	1,07	1,05	44,70	0.5 mm ²
		0.437	0.386	0.236	0.042	0.041	1.760	0.6 mm ²
4	ABB 4 TKPK F80 P1 001	11,10	9,80	6,50	1,30	1,30	44,70	0.75 mm ²
		0.437	0.386	0.256	0.051	0.051	1.760	1.0 mm ²

Socket Contact

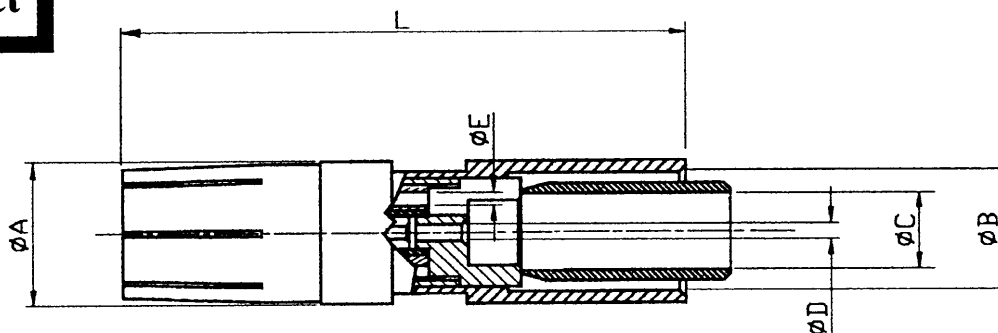

Metric
Imperial

Contact Size AWG*	Part Number	A	B	C	D	E	L	Use With Conductors
4	ABB 4 TKSK F80 P1	11,10	9,80	6,00	1,07	1,05	43,05	0.5 mm ²
		0.437	0.386	0.236	0.042	0.041	1.695	0.6 mm ²
4	ABB 4 TKSK F80 P1 001	11,10	9,80	6,50	1,30	1,30	43,05	0.75 mm ²
		0.437	0.386	0.256	0.051	0.051	1.695	1.0 mm ²

* Consult factory for contact arrangement details

Square Flange Receptacle

Front Mounting (No Accessory Thread)

Style: ABCIRH00A/ABCIRH00A...M6

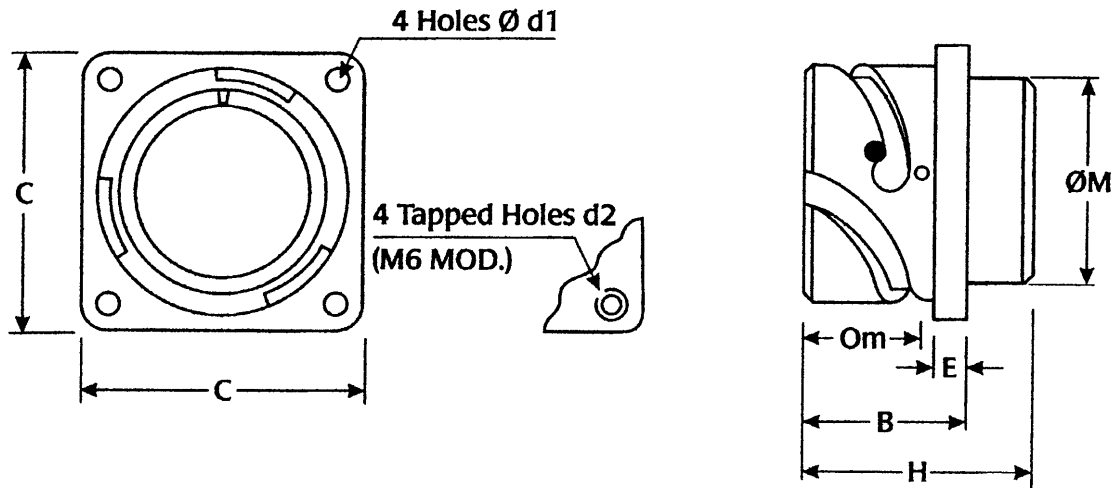

Metric
Imperial

See page 82 for panel mounting details

Shell Size	B Max	C Max	d1 +0,2 -0 +0.008-0	d2 Thread	E Max	M Max	H Max	Om Min Overlap Mated
10SL	17,60 0.693	25,70 1.012	3,20 0.126	M4	3,00 0.118	16,10 0.634	25,08 0.987	11,10 0.437
14S	18,00 0.709	30,30 1.193	3,20 0.126	M4	3,40 0.134	19,20 0.756	25,08 0.987	11,10 0.437
16S	18,00 0.709	32,80 1.291	3,20 0.126	M4	3,40 0.134	22,40 0.882	25,08 0.987	11,10 0.437
16	22,80 0.898	32,80 1.291	3,20 0.126	M4	3,40 0.134	22,40 0.882	32,85 1.293	15,85 0.624
18	23,60 0.929	35,30 1.390	3,20 0.126	M4	4,20 0.165	25,60 1.008	32,85 1.293	15,85 0.624
20	23,60 0.929	38,30 1.508	3,20 0.126	M4	4,20 0.165	29,00 1.142	32,85 1.293	15,85 0.624
22	23,60 0.929	41,30 1.626	3,20 0.126	M4	4,20 0.165	31,92 1.257	32,85 1.293	15,75 0.620
24	25,20 0.992	44,80 1.764	3,70 0.146	M4	4,20 0.165	35,30 1.390	32,85 1.293	15,75 0.620
28	25,20 0.992	51,10 2.012	3,70 0.146	M5	4,20 0.165	41,40 1.630	32,85 1.293	15,75 0.620
32	26,80 1.055	57,30 2.256	4,30 0.169	M5	4,20 0.165	47,80 1.882	32,85 1.293	15,75 0.620
36	26,80 1.055	63,80 2.512	4,30 0.169	M5	4,20 0.165	52,60 2.071	32,85 1.293	15,75 0.620
40	26,80 1.055	70,20 2.764	4,30 0.169	M5	4,20 0.165	59,00 2.323	32,85 1.293	15,75 0.620



Square Flange Receptacle

Front Mounting (With Accessory Thread)

Style: ABCIRH00T/ABCIRH00T...M6

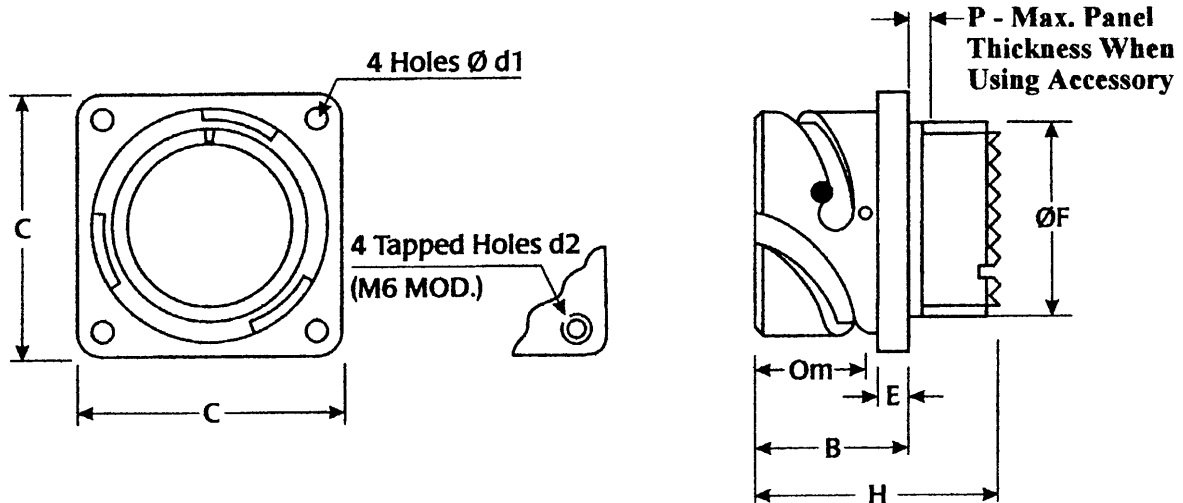

Metric
Imperial

See page 82 for panel mounting details

Shell Size	B Max	C Max	d1 +0,2 -0 +0.008-0	d2 Thread	E Max	F Thread Dia. Class 2A	H Max	P	Om Min Overlap Mated
10SL	17,60 0.693	25,70 1.012	3,20 0.126	M4	3,00 0.118	5/8" x 24 UNEF	28,78 1.133	3,30 0.130	11,10 0.437
14S	18,00 0.709	30,30 1.193	3,20 0.126	M4	3,40 0.134	3/4" x 20 UNEF	28,78 1.133	3,30 0.130	11,10 0.437
16S	18,00 0.709	32,80 1.291	3,20 0.126	M4	3,40 0.134	7/8" x 20 UNEF	28,78 1.133	3,30 0.130	11,10 0.437
16	22,80 0.898	32,80 1.291	3,20 0.126	M4	3,40 0.134	7/8" x 20 UNEF	36,30 1.429	3,30 0.130	15,85 0.624
18	23,60 0.929	35,30 1.390	3,20 0.126	M4	4,20 0.165	1" x 20 UNEF	36,30 1.429	3,30 0.130	15,85 0.624
20	23,60 0.929	38,30 1.508	3,20 0.126	M4	4,20 0.165	1 1/8" x 18 UNEF	36,30 1.429	3,30 0.130	15,85 0.624
22	23,60 0.929	41,30 1.626	3,20 0.126	M4	4,20 0.165	1 1/4" x 18 UNEF	36,30 1.429	3,30 0.130	15,75 0.620
24	25,20 0.992	44,80 1.764	3,70 0.146	M4	4,20 0.165	1 3/8" x 18 UNEF	36,30 1.429	3,30 0.130	15,75 0.620
28	25,20 0.992	51,10 2.012	3,70 0.146	M5	4,20 0.165	1 5/8" x 18 UNEF	36,30 1.429	3,30 0.130	15,75 0.620
32	26,80 1.055	57,30 2.256	4,30 0.169	M5	4,20 0.165	1 7/8" x 16 UN	36,30 1.429	3,30 0.130	15,75 0.620
36	26,80 1.055	63,80 2.512	4,30 0.169	M5	4,20 0.165	2 1/16" x 16 UNS	36,30 1.429	3,30 0.130	15,75 0.620
40	26,80 1.055	70,20 2.764	4,30 0.169	M5	4,20 0.165	2 5/16" x 16 UN	36,30 1.429	3,30 0.130	15,75 0.620

ABCIRH '00' Style Connector & Accessory

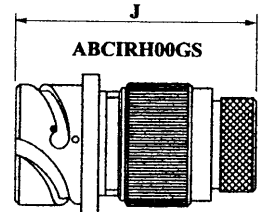
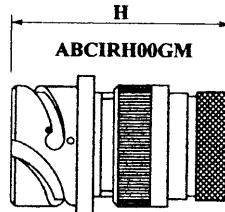
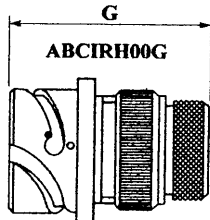
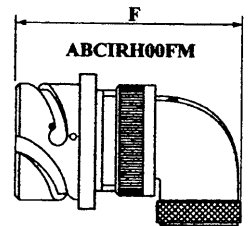
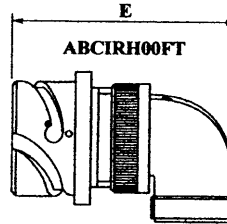
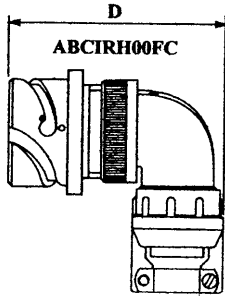
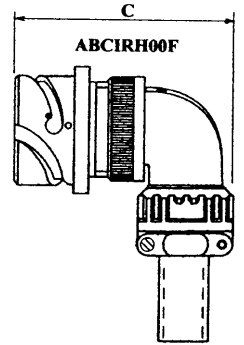
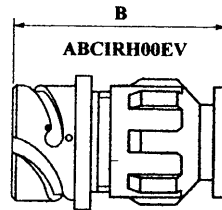
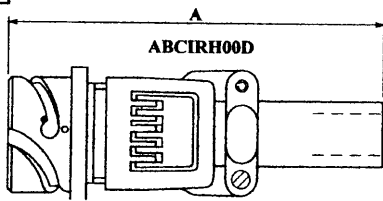

Metric
Imperial

Shell Size	A	B	C	D	E	F	G	H	J
10SL	109,00 4.291	44,00 1.732	57,00 2.244	58,00 2.283	54,00 2.126	54,00 2.126	49,00 1.929	53,00 2.087	*
14S	107,00 4.213	44,00 1.732	61,00 2.402	60,00 2.362	56,00 2.205	56,00 2.205	49,00 1.929	53,00 2.087	*
16S	104,00 4.094	44,00 1.732	64,00 2.520	64,00 2.520	60,00 2.362	60,00 2.362	49,00 1.929	53,00 2.087	*
16	111,00 4.370	54,00 2.126	71,00 2.795	71,00 2.795	67,00 2.638	67,00 2.638	57,00 2.244	65,00 2.559	*
18	115,00 4.528	54,00 2.126	76,00 2.992	76,00 2.992	72,00 2.835	72,00 2.835	59,00 2.323	65,00 2.559	74,00 2.913
20	114,00 4.488	54,00 2.126	81,00 3.189	82,00 3.228	77,00 3.031	77,00 3.031	60,00 2.362	68,00 2.677	80,00 3.150
22	114,00 4.488	54,00 2.126	81,00 2.189	82,00 3.228	77,00 3.031	77,00 3.031	63,00 2.480	68,00 2.677	80,00 3.150
24	109,00 4.291	54,00 2.126	89,00 3.504	89,00 3.504	85,00 3.346	85,00 3.346	60,00 2.362	68,00 2.677	80,00 3.150
28	119,00 4.685	54,00 2.126	88,00 3.465	89,00 3.504	85,00 3.346	85,00 3.346	63,00 2.480	67,00 2.638	81,00 3.189
32	115,00 4.528	54,00 2.126	98,00 3.858	101,00 3.976	95,00 3.740	95,00 3.740	61,00 2.402	67,00 2.638	80,00 3.189
36	112,00 4.409	54,00 2.126	104,00 4.094	105,00 4.134	101,00 3.976	101,00 3.976	67,00 2.638	68,00 2.677	80,00 3.189
40	N/A	54,00 2.126	111,00 4.370	112,00 4.409	107,00 4.213	107,00 4.213	68,00 2.677	68,00 2.677	80,00 3.189

* Please consult factory for availability.

ABCIRH '00' Style Connector & Accessory cont.

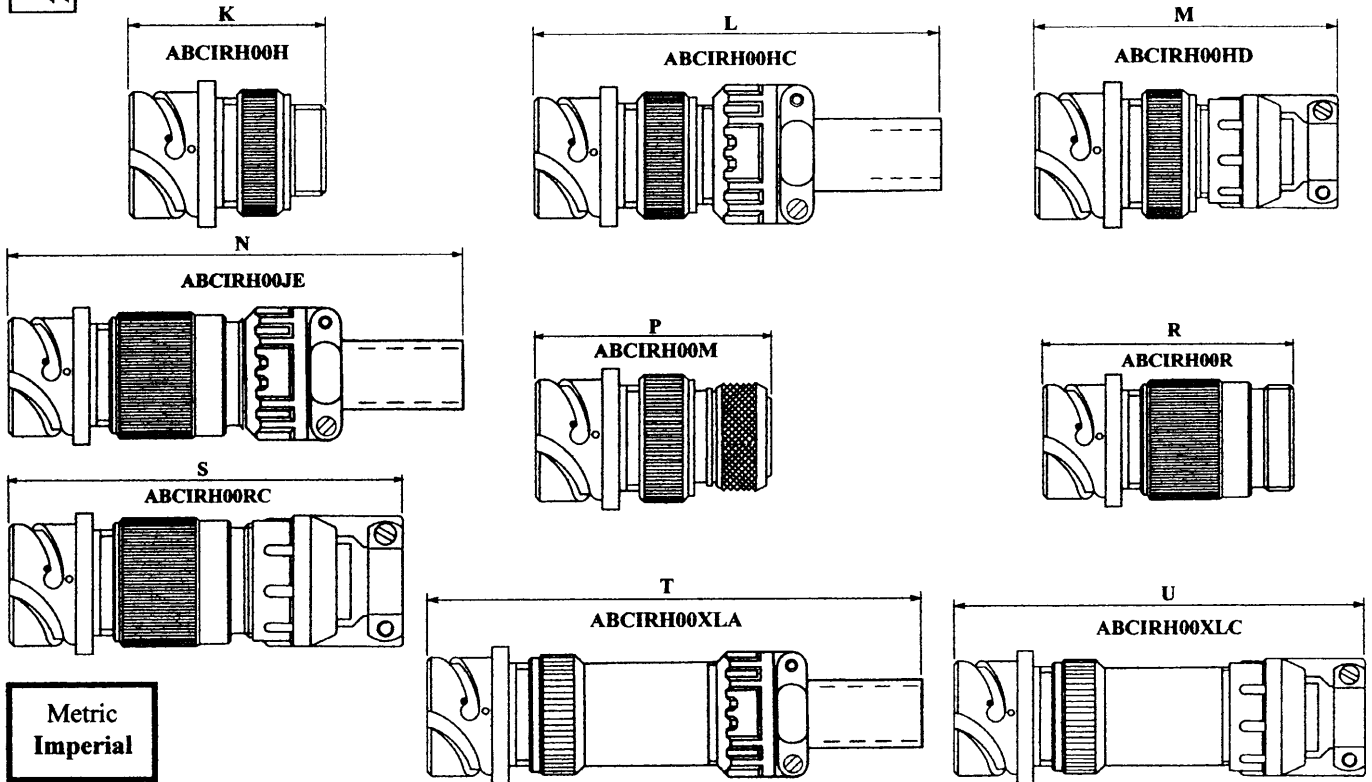

Shell Size	K	L	M	N	P	R	S	T	U
10SL	50,00 1.696	122,00 4.803	81,00 3.189	121,00 4.764	53,00 2.087	51,00 2.008	82,00 3.228	140,00 5.512	101,00 3.976
14S	50,00 1.969	118,00 4.646	81,00 3.189	118,00 4.646	56,00 2.205	51,00 2.008	82,00 3.228	137,00 5.394	101,00 3.976
16S	50,00 1.969	120,00 4.724	81,00 3.189	115,00 4.528	56,00 2.205	51,00 2.008	82,00 3.228	134,00 5.276	101,00 3.976
16	57,00 2.244	123,00 4.843	88,00 3.465	124,00 4.882	63,00 2.480	60,00 2.362	91,00 3.583	152,00 5.984	121,00 4.764
18	59,00 2.323	124,00 4.882	92,00 3.622	126,00 4.961	66,00 2.598	66,00 2.598	99,00 3.898	148,00 5.827	121,00 4.764
20	59,00 2.323	120,00 4.724	92,00 3.622	123,00 4.843	66,00 2.598	66,00 2.598	99,00 3.898	145,00 5.709	121,00 4.764
22	59,00 2.323	120,00 4.724	92,00 3.622	123,00 4.843	66,00 2.598	66,00 2.598	99,00 3.898	145,00 5.709	121,00 4.764
24	59,00 2.323	107,00 4.213	95,00 3.740	123,00 4.843	66,00 2.598	69,00 2.716	105,00 4.134	142,00 5.591	124,00 4.882
28	59,00 2.323	107,00 4.213	95,00 3.740	124,00 4.882	65,00 2.559	70,00 2.756	106,00 4.173	149,00 5.866	131,00 5.157
32	58,00 2.283	106,00 4.173	100,00 3.937	120,00 4.724	65,00 2.559	69,00 2.716	111,00 4.370	146,00 5.748	137,00 5.394
36	58,00 2.283	106,00 4.173	107,00 4.213	117,00 4.606	65,00 2.559	69,00 2.716	117,00 4.606	143,00 5.630	144,00 5.669
40	58,00 2.283	103,00 4.055	107,00 4.213	114,00 4.488	65,00 2.559	70,00 2.756	112,00 4.409	140,00 5.512	144,00 5.669

Cable Mounted Receptacle

Style: ABCIRH01T

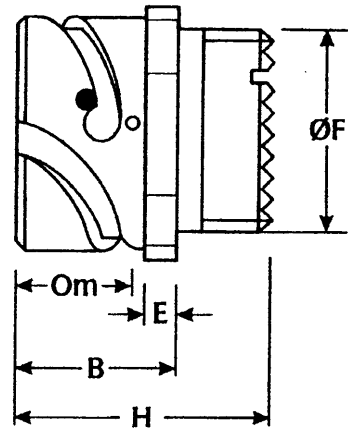
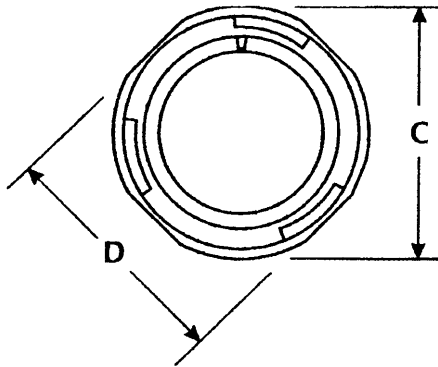

Metric
Imperial

Shell Size	B Max	C Max	D Max	E Max	F Thread Dia. Class 2A	H Max	Om Min Overlap Mated
10SL	17,60 0.693	25,20 0.992	20,80 0.819	3,00 0.118	5/8" x 24 UNEF	28,78 1.133	11,10 0.437
14S	18,00 0.709	29,80 1.173	25,60 1.008	3,40 0.134	3/4" x 20 UNEF	28,78 1.133	11,10 0.437
16S	18,00 0.709	32,30 1.272	28,80 1.134	3,40 0.134	7/8" x 20 UNEF	28,78 1.133	11,10 0.437
16	22,80 0.898	32,30 1.272	28,80 1.134	3,40 0.134	7/8" x 20 UNEF	36,30 1.429	15,85 0.624
18	23,60 0.929	34,80 1.370	31,90 1.256	4,20 0.165	1" x 20 UNEF	36,30 1.429	15,85 0.624
20	23,60 0.929	37,80 1.488	35,10 1.382	4,20 0.165	1 1/8" x 18 UNEF	36,30 1.429	15,85 0.624
22	23,60 0.929	41,10 1.618	38,30 1.508	4,20 0.165	1 1/4" x 18 UNEF	36,30 1.429	15,75 0.620
24	25,20 0.992	44,60 1.756	41,50 1.634	4,20 0.165	1 3/8" x 18 UNEF	36,30 1.429	15,75 0.620
28	25,20 0.992	50,90 2.004	47,80 1.882	4,20 0.165	1 5/8" x 18 UNEF	36,30 1.429	15,75 0.620
32	26,80 1.055	57,10 2.248	54,20 2.134	4,20 0.165	1 7/8" x 16 UN	36,30 1.429	15,75 0.620
36	26,80 1.055	63,80 2.512	60,80 2.394	4,20 0.165	2 1/16" x 16 UNS	36,30 1.429	15,75 0.620
40	26,80 1.055	70,00 2.756	66,70 2.626	4,20 0.165	2 5/16" x 16 UN	36,30 1.429	15,75 0.620

ABCIRH '01' Style Connector & Accessory

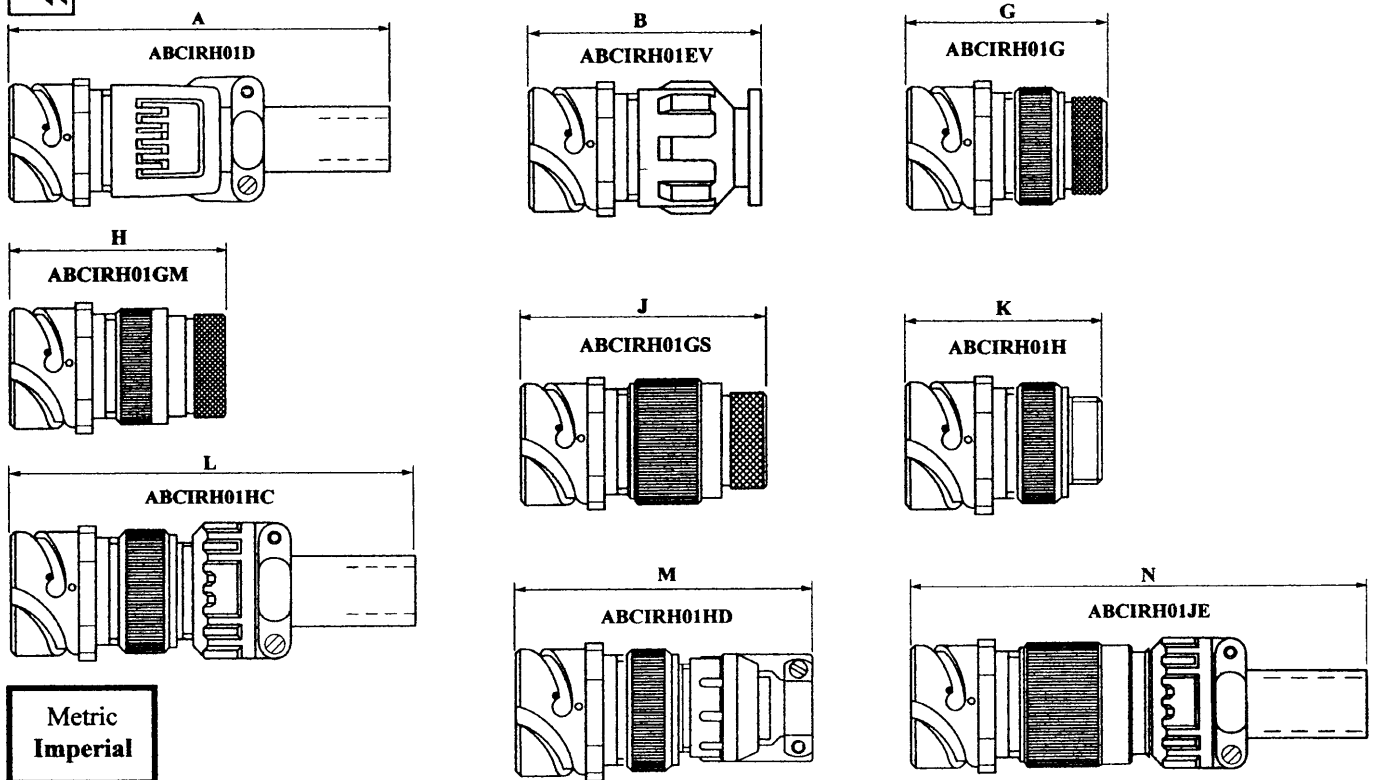

Metric
Imperial

Shell Size	A	B	G	H	J	K	L	M	N
10SL	109,00 4.291	44,00 1.732	49,00 1.929	53,00 2.087	*	50,00 1.696	122,00 4.803	81,00 3.189	121,00 4.764
14S	107,00 4.213	44,00 1.732	49,00 1.929	53,00 2.087	*	50,00 1.969	118,00 4.646	81,00 3.189	118,00 4.646
16S	104,00 4.094	44,00 1.732	49,00 1.929	53,00 2.087	*	50,00 1.969	120,00 4.724	81,00 3.189	115,00 4.528
16	111,00 4.370	54,00 2.126	57,00 2.244	65,00 2.559	*	57,00 2.244	123,00 4.843	88,00 3.465	124,00 4.882
18	115,00 4.528	54,00 2.126	59,00 2.323	65,00 2.559	74,00 2.913	59,00 2.323	124,00 4.882	92,00 3.622	126,00 4.961
20	114,00 4.488	54,00 2.126	60,00 2.362	68,00 2.677	80,00 3.150	59,00 2.323	120,00 4.724	92,00 3.622	123,00 4.843
22	114,00 4.488	54,00 2.126	63,00 2.480	68,00 2.677	80,00 3.150	59,00 2.323	120,00 4.724	92,00 3.622	123,00 4.843
24	109,00 4.291	54,00 2.126	60,00 2.362	68,00 2.677	80,00 3.150	59,00 2.323	107,00 4.213	95,00 3.740	123,00 4.843
28	119,00 4.685	54,00 2.126	63,00 2.480	67,00 2.638	81,00 3.189	59,00 2.323	107,00 4.213	95,00 3.740	124,00 4.882
32	115,00 4.528	54,00 2.126	61,00 2.402	67,00 2.638	80,00 3.189	58,00 2.283	106,00 4.173	100,00 3.937	120,00 4.724
36	112,00 4.409	54,00 2.126	67,00 2.638	68,00 2.677	80,00 3.189	58,00 2.283	106,00 4.173	107,00 4.213	117,00 4.606
40	N/A	54,00 2.126	68,00 2.677	68,00 2.677	80,00 3.189	58,00 2.283	103,00 4.055	107,00 4.213	114,00 4.488

* Please consult factory for availability.

ABCIRH '01' Style Connector & Accessory cont.

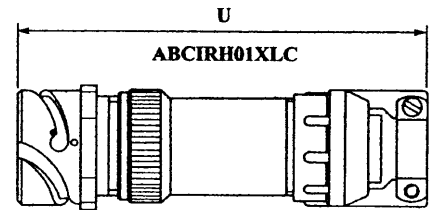
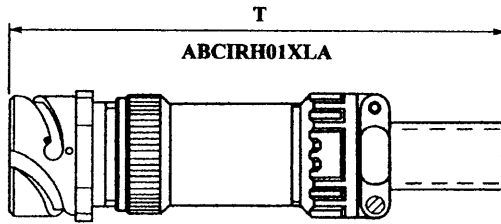
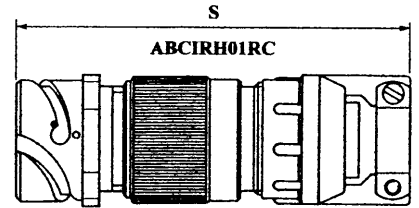
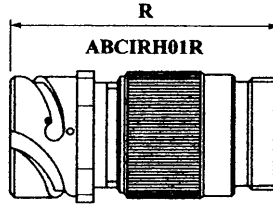
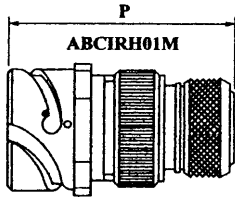

Metric
Imperial

Shell Size	P	R	S	T	U
10SL	53,00	51,00	82,00	140,00	101,00
	2.087	2.008	3.228	5.512	3.976
14S	56,00	51,00	82,00	137,00	101,00
	2.205	2.008	3.228	5.394	3.976
16S	56,00	51,00	82,00	134,00	101,00
	2.205	2.008	3.228	5.276	3.976
16	63,00	60,00	91,00	152,00	121,00
	2.480	2.362	3.583	5.984	4.764
18	66,00	66,00	99,00	148,00	121,00
	2.598	2.598	3.898	5.827	4.764
20	66,00	66,00	99,00	145,00	121,00
	2.598	2.598	3.898	5.709	4.764
22	66,00	66,00	99,00	145,00	121,00
	2.598	2.598	3.898	5.709	4.764
24	66,00	69,00	105,00	142,00	124,00
	2.598	2.716	4.134	5.591	4.882
28	65,00	70,00	106,00	149,00	131,00
	2.559	2.756	4.173	5.866	5.157
32	65,00	69,00	111,00	146,00	137,00
	2.559	2.716	4.370	5.748	5.394
36	65,00	69,00	117,00	143,00	144,00
	2.559	2.716	4.606	5.630	5.669
40	65,00	70,00	112,00	140,00	144,00
	2.559	2.756	4.409	5.512	5.669

Square Flange Receptacle

Rear Mounting (No Accessory Thread)

Style: ABCIRH03A/ABCIRH03A...M6

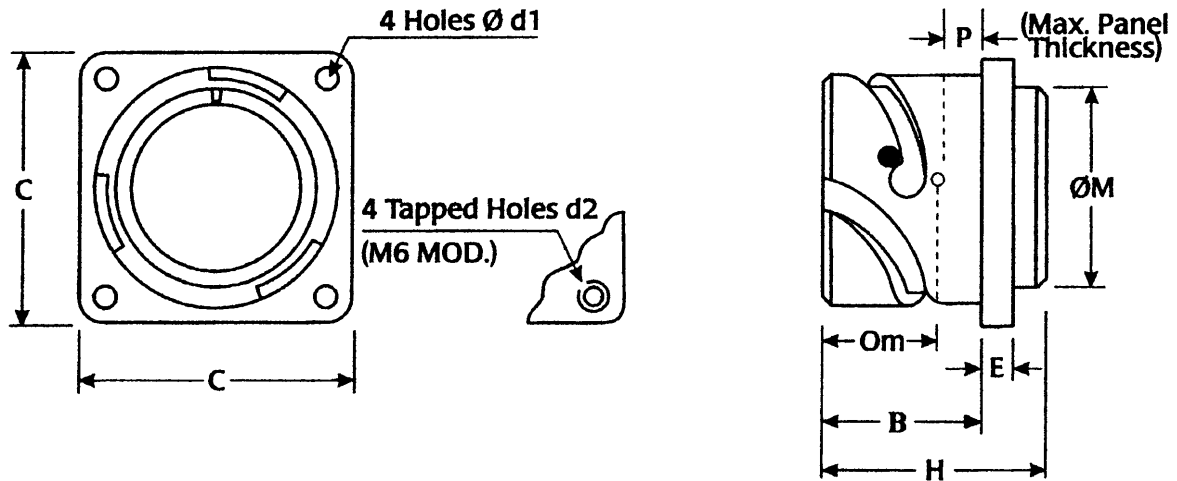

Metric
Imperial

See page 82 for panel mounting details

Note. Maximum panel thickness when using cap head screws.
When using countersunk screws, maximum panel thickness = 7.5 mm.

Shell Size	B Max	C Max	d1 +0,2 -0 +0.008-0	d2 Thread	E Max	M Max	H Max	P See Note	Om Min Overlap Mated
10SL	18,60 0.732	25,70 1.012	3,20 0.126	M4	3,00 0.118	16,10 0.634	25,08 0.987	3,30 0.130	11,10 0.437
14S	18,60 0.732	30,30 1.193	3,20 0.126	M4	3,40 0.134	19,20 0.756	25,08 0.987	3,30 0.130	11,10 0.437
16S	18,60 0.732	32,80 1.291	3,20 0.126	M4	3,40 0.134	22,40 0.882	25,08 0.987	3,30 0.130	11,10 0.437
16	21,90 0.862	32,80 1.291	3,20 0.126	M4	3,40 0.134	22,40 0.882	32,72 1.288	3,30 0.130	15,85 0.624
18	23,45 0.923	35,30 1.390	3,20 0.126	M4	4,20 0.165	25,60 1.008	32,72 1.288	3,30 0.130	15,85 0.624
20	23,45 0.923	38,30 1.508	3,20 0.126	M4	4,20 0.165	29,00 1.142	32,72 1.288	3,30 0.130	15,85 0.624
22	23,45 0.923	41,30 1.626	3,20 0.126	M4	4,20 0.165	31,92 1.257	32,72 1.288	3,30 0.130	15,75 0.620
24	23,45 0.923	44,80 1.764	3,70 0.146	M4	4,20 0.165	35,30 1.390	32,72 1.288	3,30 0.130	15,75 0.620
28	24,45 0.963	51,10 2.012	3,70 0.146	M5	4,20 0.165	41,40 1.630	35,80 1.409	3,30 0.130	15,75 0.620
32	24,45 0.963	57,30 2.256	4,30 0.169	M5	4,20 0.165	47,80 1.882	36,80 1.449	3,30 0.130	15,75 0.620
36	24,45 0.963	63,80 2.512	4,30 0.169	M5	4,20 0.165	52,60 2.071	36,80 1.449	3,30 0.130	15,75 0.620
40	24,45 0.963	70,20 2.764	4,30 0.169	M5	4,20 0.165	59,00 2.323	36,80 1.449	3,30 0.130	15,75 0.620

Square Flange Receptacle

Rear Mounting (With Accessory Thread)

AB Style: ABCIRH03T/ABCIRH03T...M6

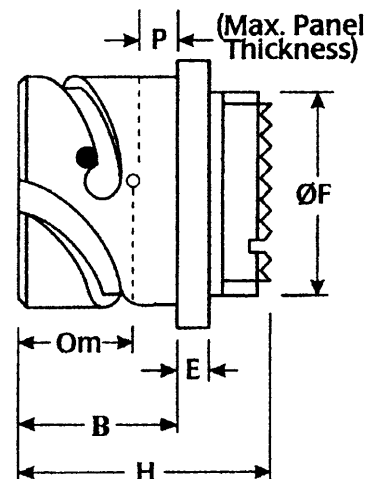
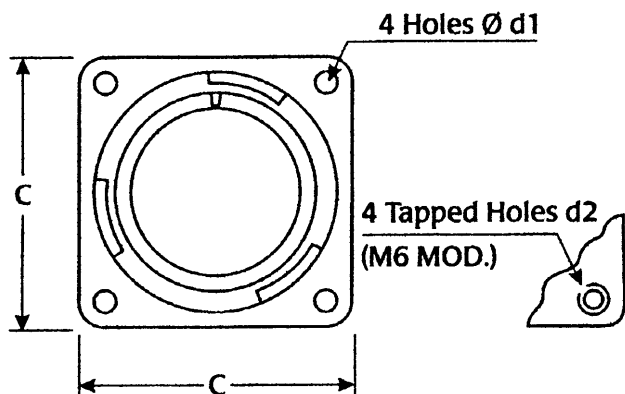

Metric
Imperial

See page 82 for panel mounting details

Note. Maximum panel thickness when using cap head screws.
When using countersunk screws, maximum panel thickness = 7.5 mm.

Shell Size	B Max	C Max	d1 +0,2 -0 +0.008-0	d2 Thread	E Max	F Thread Dia. Class 2A	H Max	P See Note	Om Min Overlap Mated
10SL	18,60 0.732	25,70 1.012	3,20 0.126	M4	3,00 0.118	5/8" x 24 UNEF	29,50 1.161	3,30 0.130	11,10 0.437
14S	18,60 0.732	30,30 1.193	3,20 0.126	M4	3,40 0.134	3/4" x 20 UNEF	29,50 1.161	3,30 0.130	11,10 0.437
16S	18,60 0.732	32,80 1.291	3,20 0.126	M4	3,40 0.134	7/8" x 20 UNEF	29,50 1.161	3,30 0.130	11,10 0.437
16	21,90 0.862	32,80 1.291	3,20 0.126	M4	3,40 0.134	7/8" x 20 UNEF	42,00 1.654	3,30 0.130	15,85 0.624
18	23,45 0.923	35,30 1.390	3,20 0.126	M4	4,20 0.165	1" x 20 UNEF	42,00 1.654	3,30 0.130	15,85 0.624
20	23,45 0.923	38,30 1.508	3,20 0.126	M4	4,20 0.165	1 1/8" x 18 UNEF	42,00 1.654	3,30 0.130	15,85 0.624
22	23,45 0.923	41,30 1.626	3,20 0.126	M4	4,20 0.165	1 1/4" x 18 UNEF	42,00 1.654	3,30 0.130	15,75 0.620
24	23,45 0.923	44,80 1.764	3,70 0.146	M4	4,20 0.165	1 3/8" x 18 UNEF	42,00 1.654	3,30 0.130	15,75 0.620
28	24,45 0.963	51,10 2.012	3,70 0.146	M5	4,20 0.165	1 5/8" x 18 UNEF	42,00 1.654	3,30 0.130	15,75 0.620
32	24,45 0.963	57,30 2.256	4,30 0.169	M5	4,20 0.165	1 7/8" x 16 UN	42,00 1.654	3,30 0.130	15,75 0.620
36	24,45 0.963	63,80 2.512	4,30 0.169	M5	4,20 0.165	2 1/16" x 16 UNS	42,00 1.654	3,30 0.130	15,75 0.620
40	24,45 0.963	70,20 2.764	4,30 0.169	M5	4,20 0.165	2 5/16" x 16 UN	42,00 1.654	3,30 0.130	15,75 0.620

ABCIRH '03' Style Connector & Accessory

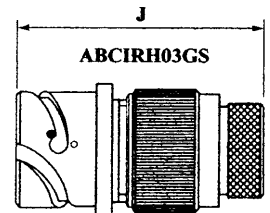
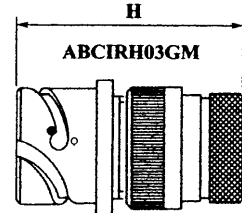
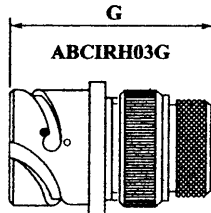
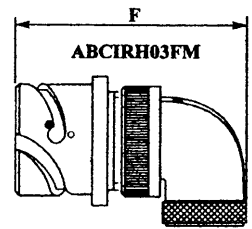
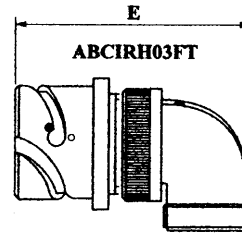
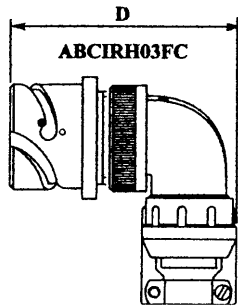
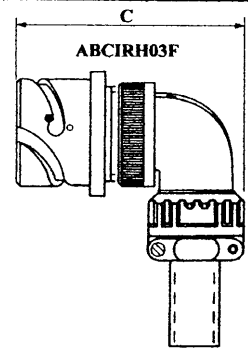
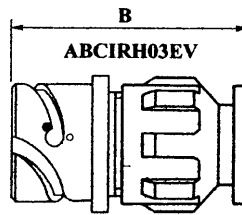
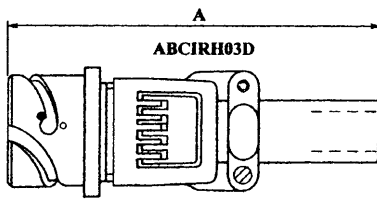

Metric
Imperial

Shell Size	A	B	C	D	E	F	G	H	J
10SL	109,00 4.291	44,00 1.732	58,00 2.283	58,00 2.283	55,00 2.165	55,00 2.165	50,00 1.968	54,00 2.126	*
14S	108,00 4.252	44,00 1.732	61,00 2.402	61,00 2.402	57,00 2.244	57,00 2.244	50,00 1.968	54,00 2.126	*
16S	105,00 4.134	44,00 1.732	65,00 2.559	65,00 2.559	61,00 2.402	61,00 2.402	50,00 1.968	54,00 2.126	*
16	117,00 4.606	60,00 2.362	77,00 3.031	77,00 3.031	73,00 2.874	73,00 2.874	63,00 2.480	70,00 2.756	*
18	121,00 4.764	60,00 2.362	82,00 3.228	82,00 3.228	78,00 3.071	78,00 3.071	65,00 2.559	70,00 2.756	80,00 3.150
20	120,00 4.724	60,00 2.362	87,00 3.425	88,00 3.465	83,00 3.268	83,00 3.268	66,00 2.598	74,00 2.913	86,00 3.386
22	120,00 4.724	60,00 2.362	87,00 3.425	88,00 3.465	83,00 3.268	83,00 3.268	68,00 2.677	74,00 2.913	86,00 3.386
24	114,00 4.488	60,00 2.362	95,00 3.740	95,00 3.740	91,00 3.583	91,00 3.583	66,00 2.598	74,00 2.913	86,00 3.386
28	124,00 4.882	60,00 2.362	94,00 3.700	94,00 3.700	90,00 3.543	90,00 3.543	68,00 2.677	73,00 2.874	87,00 3.425
32	121,00 4.764	60,00 2.362	104,00 4.094	107,00 4.213	100,00 3.937	100,00 3.937	67,00 2.638	73,00 2.874	86,00 3.386
36	118,00 4.646	60,00 2.362	110,00 4.331	111,00 4.370	106,00 4.173	106,00 4.173	72,00 2.835	74,00 2.913	88,00 3.465
40	NA	60,00 2.362	117,00 4.606	117,00 4.606	113,00 4.449	113,00 4.449	74,00 2.913	74,00 2.913	88,00 3.465

* Please consult factory for availability.

ABCIRH '03' Style Connector & Accessory cont.

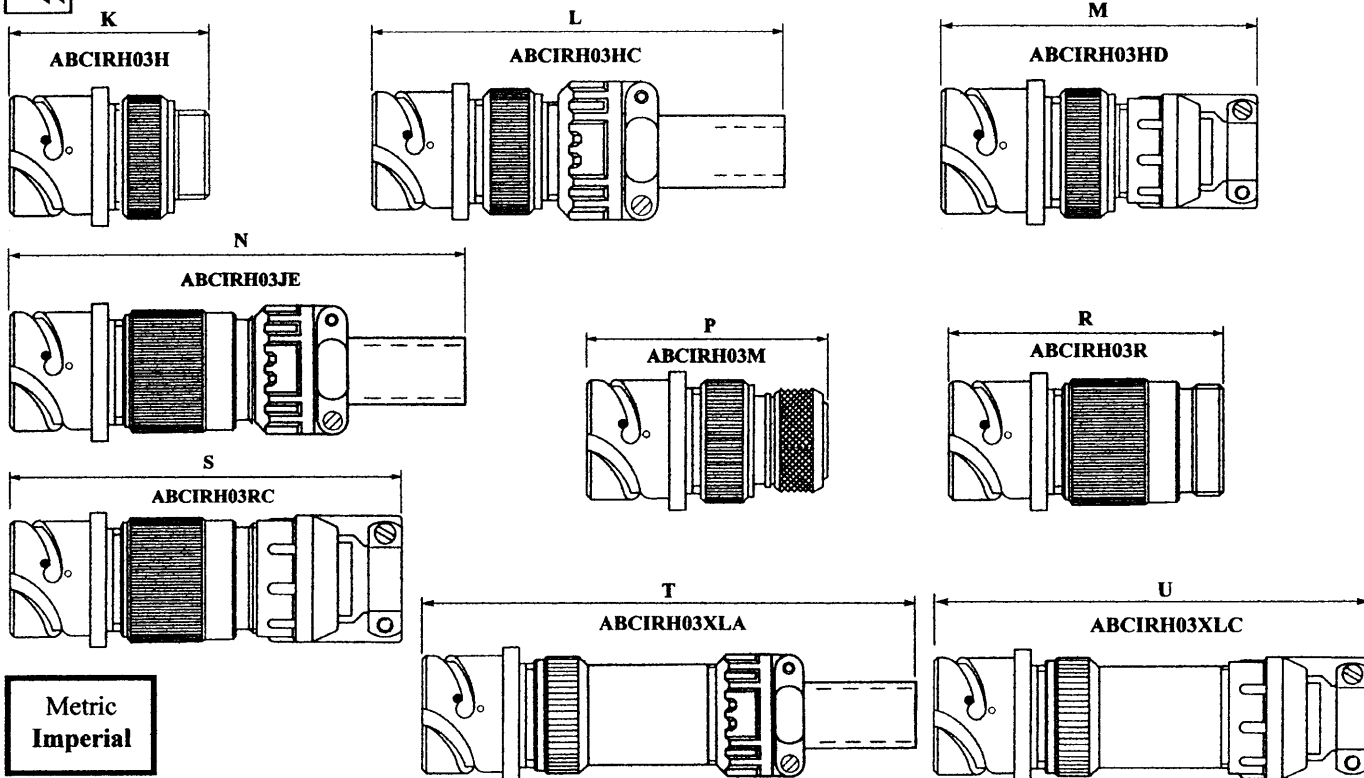

Shell Size	K	L	M	N	P	R	S	T	U
10SL	50,00 1.969	123,00 4.843	81,00 3.189	122,00 4.803	54,00 2.126	52,00 2.047	83,00 3.268	141,00 5.551	102,00 4.016
14S	50,00 1.969	119,00 4.685	81,00 3.189	118,00 4.646	56,00 2.205	52,00 2.047	83,00 3.268	138,00 5.433	102,00 4.016
16S	50,00 1.969	121,00 4.764	81,00 3.189	115,00 4.528	56,00 2.205	52,00 2.047	83,00 3.268	135,00 5.315	102,00 4.016
16	63,00 2.480	129,00 5.079	94,00 3.700	129,00 5.079	69,00 2.716	66,00 2.598	97,00 3.819	157,00 6.181	126,00 4.961
18	65,00 2.559	130,00 5.118	97,00 3.819	132,00 5.197	72,00 2.835	72,00 2.835	104,00 4.094	154,00 6.063	126,00 4.961
20	65,00 2.559	126,00 4.961	97,00 3.819	129,00 5.079	72,00 2.835	72,00 2.835	104,00 4.094	151,00 5.945	126,00 4.961
22	65,00 2.559	126,00 4.961	97,00 3.819	129,00 5.079	72,00 2.835	72,00 2.835	104,00 4.094	151,00 5.945	126,00 4.961
24	65,00 2.559	113,00 4.449	101,00 3.976	129,00 5.079	72,00 2.835	75,00 2.593	110,00 4.331	148,00 5.827	130,00 5.118
28	65,00 2.559	113,00 4.449	101,00 3.976	130,00 5.118	71,00 2.795	76,00 2.992	111,00 4.370	155,00 6.102	137,00 5.394
32	64,00 2.520	112,00 4.409	106,00 4.173	125,00 4.921	71,00 2.795	75,00 2.593	117,00 4.606	152,00 5.984	143,00 5.630
36	64,00 2.520	112,00 4.409	112,00 4.409	122,00 4.803	71,00 2.795	75,00 2.593	123,00 4.842	148,00 5.827	149,00 5.866
40	64,00 2.520	109,00 4.291	112,00 4.409	120,00 4.724	71,00 2.795	76,00 2.992	118,00 4.646	145,00 5.709	149,00 5.866

Size 49 Square Flange Front Mounting Receptacle

With Accessory Thread & With Grommet & Grommet Nut

AB Styles: ABCIRH04T & ABCIRH04EV

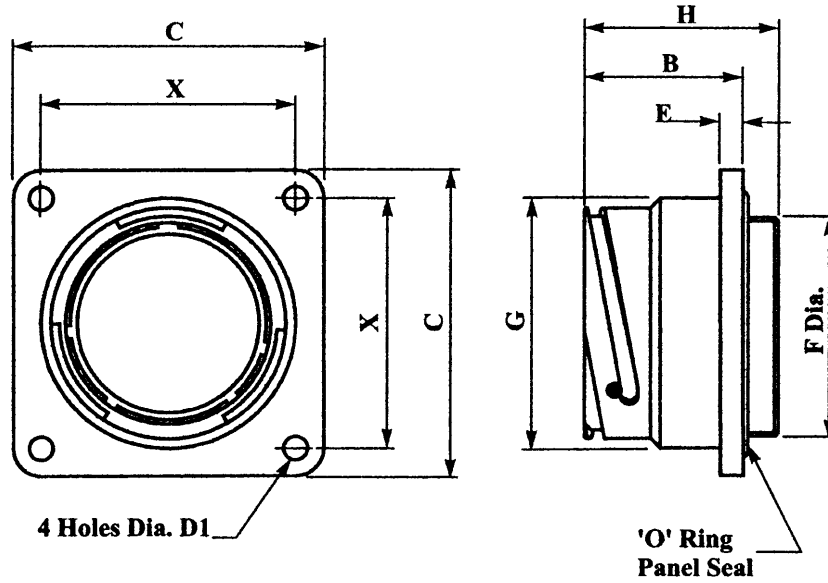

Metric
Imperial

ABCIRH04T

See page 82 for panel mounting details

Shell Size	B	C	D1 +0,2 -0 +0.008-0	E	F Thread Dia. Class 2A	G Dia.	H	X
49	56,50 2.224	110,00 4.330	8,50 0.335	8,00 0.315	2 ⁷ / ₈ " x 16 UN	90,00 3.543	62,50 2.460	90,00 3.543

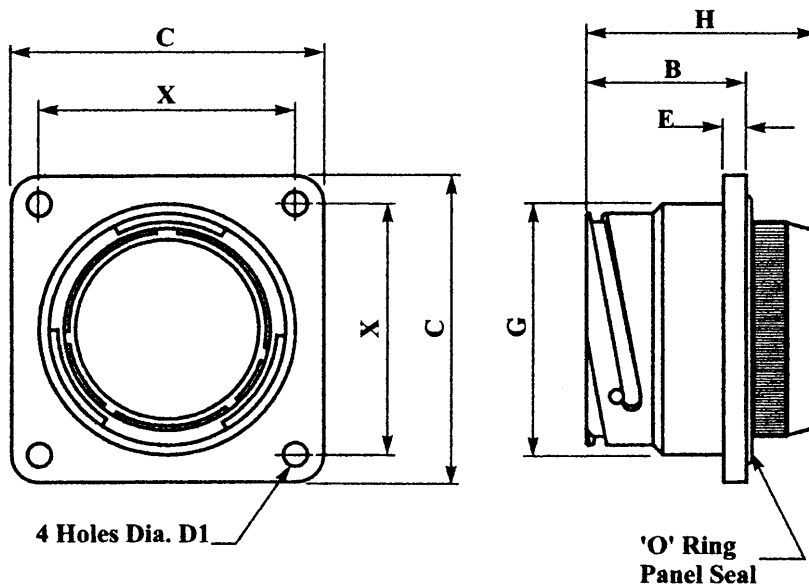

Metric
Imperial

ABCIRH04EV

See page 82 for panel mounting details

Shell Size	B	C	D1 +0,2 -0 +0.008-0	E	G Dia.	H	X
49	56,50 2.224	110,00 4.330	8,50 0.335	8,00 0.315	90,00 3.543	81,50 3.209	90,00 3.543

Size 49 Square Flange Rear Mounting Receptacle

With Accessory Thread & With Grommet & Grommet Nut

AB Styles: ABCIRH05T & ABCIRH05EV

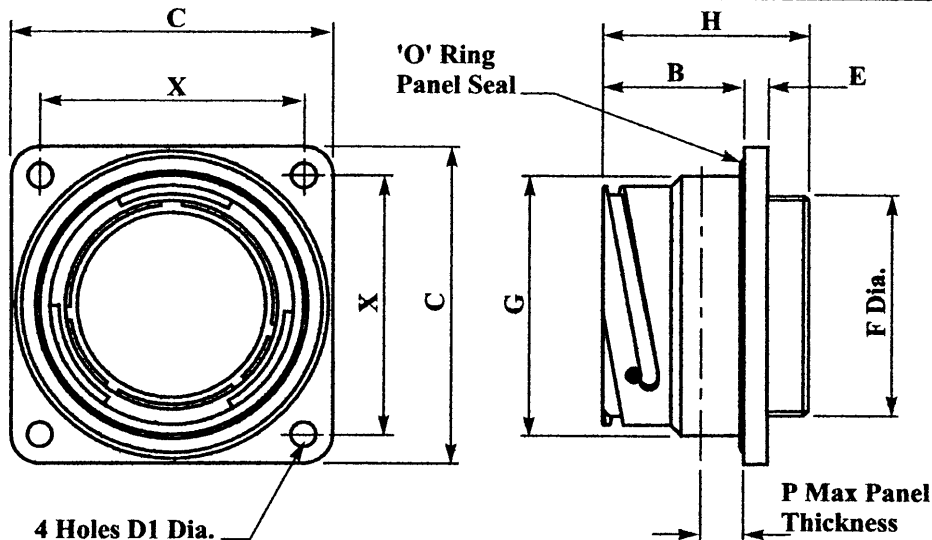

Metric
Imperial

ABCIRH05T

See page 82 for panel mounting details

Shell Size	B	C	D1 +0,2 -0 +0.008-0	E	F Thread Dia. Class 2A	G Dia.	H	P	X
49	56,50 2.224	110,00 4.330	8,50 0.335	8,00 0.315	2 7/8" x 16 UN	90,00 3.543	62,50 2.460	15,00 0.590	90,00 3.543

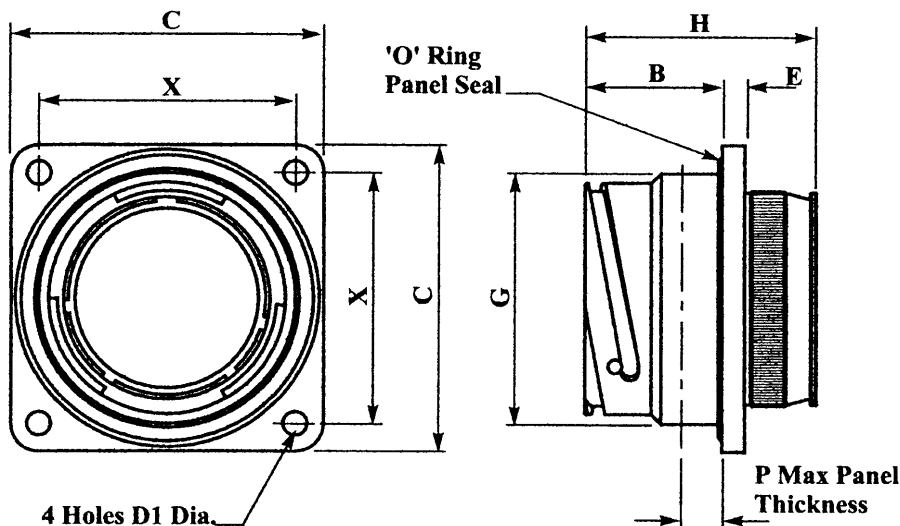

Metric
Imperial

ABCIRH05EV

See page 82 for panel mounting details

Shell Size	B	C	D1 +0,2 -0 +0.008-0	E	G Dia.	H	P	X
49	56,50 2.224	110,00 4.330	8,50 0.335	8,00 0.315	90,00 3.543	81,50 3.209	15,00 0.590	90,00 3.543

Plug - Fine Knurl Coupling Nut

Style: ABCIRH06T/ABCIRHSE06T

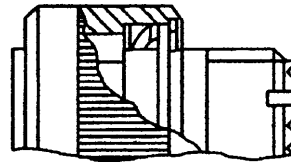
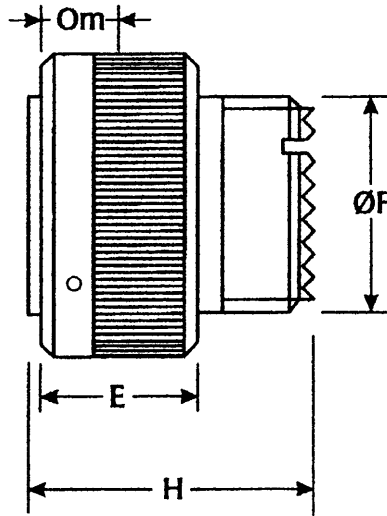
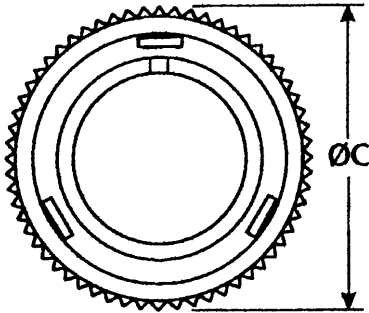

**ABCIRHSE06T
 With RFI
 Grounding**

Metric
 Imperial

Shell Size	C Max	E Max	F Thread Dia. Class 2A	H Max	Om Min Overlap Mated
10SL	24,20 0.953	17,50 0.689	5/8" x 24 UNEF	28,95 1.140	11,10 0.437
14S	30,60 1.205	17,50 0.689	3/4" x 20 UNEF	28,95 1.140	11,10 0.437
16S	33,40 1.315	17,50 0.689	7/8" x 20 UNEF	28,95 1.140	11,10 0.437
16	33,40 1.315	24,00 0.945	7/8" x 20 UNEF	36,40 1.433	15,85 0.624
18	37,30 1.468	24,00 0.945	1" x 20 UNEF	36,40 1.433	15,85 0.624
20	40,70 1.602	24,00 0.945	1 1/8" x 18 UNEF	36,40 1.433	15,85 0.624
22	44,20 1.740	24,00 0.945	1 1/4" x 18 UNEF	36,40 1.433	15,85 0.624
24	47,70 1.878	24,00 0.945	1 3/8" x 18 UNEF	36,40 1.433	15,75 0.620
28	54,50 2.146	24,00 0.945	1 5/8" x 18 UNEF	36,40 1.433	15,75 0.620
32	61,40 2.417	27,00 1.063	1 7/8" x 16 UN	36,40 1.433	15,75 0.620
36	68,00 2.677	27,00 1.063	2 1/16" x 16 UNS	36,40 1.433	15,75 0.620
40	74,00 2.913	27,00 1.063	2 5/16" x 16 UN	36,40 1.433	15,75 0.620



ABCIRH '06' Style Connector & Accessory

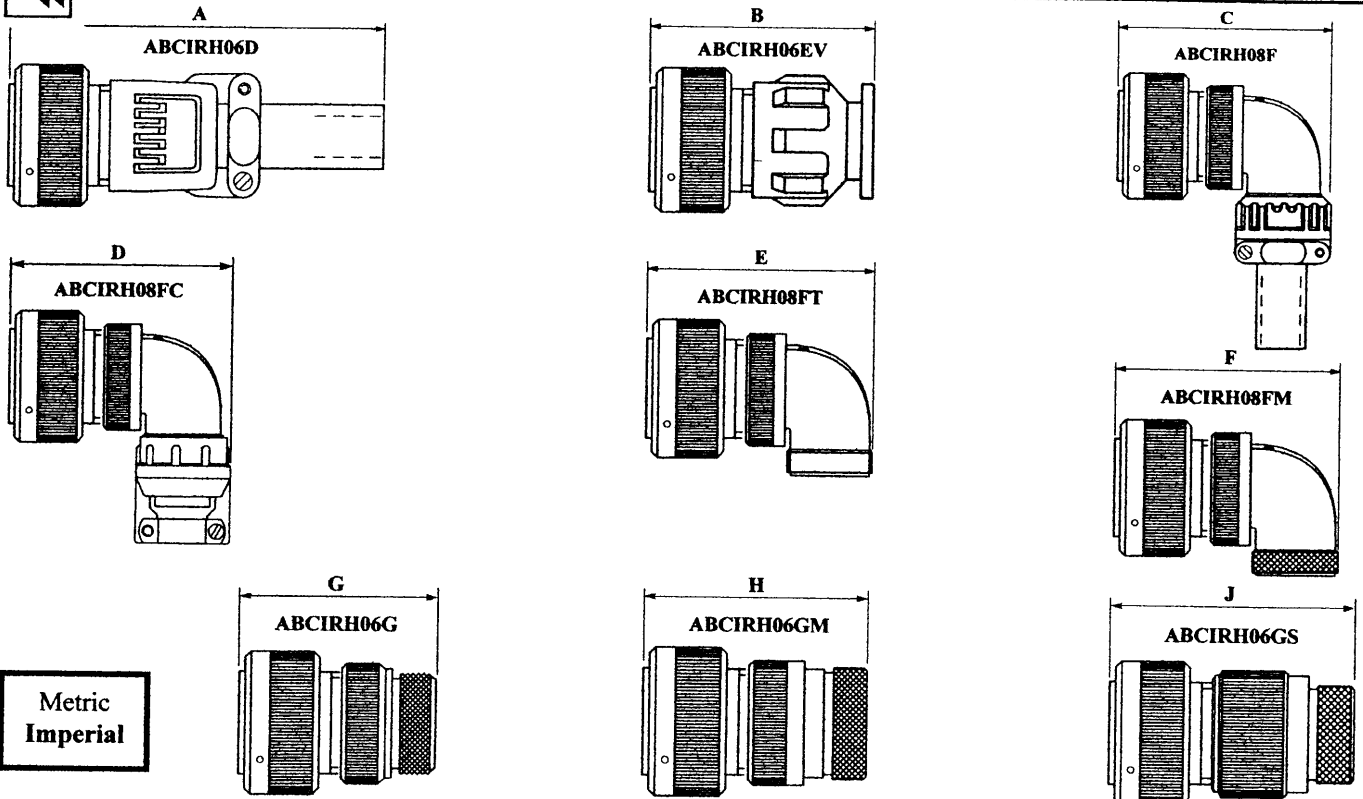

Shell Size	A	B	C	D	E	F	G	H	J
10SL	109,00 4.291	44,00 1.732	57,00 2.244	58,00 2.283	54,00 2.126	54,00 2.126	50,00 1.969	54,00 2.126	*
14S	107,00 4.213	44,00 1.732	61,00 2.402	60,00 2.362	56,00 2.205	57,00 2.244	50,00 1.969	54,00 2.126	*
16S	104,00 4.094	44,00 1.732	64,00 2.520	64,00 2.520	60,00 2.362	60,00 2.362	50,00 1.969	54,00 2.126	*
16	111,00 4.370	54,00 2.126	71,00 2.795	71,00 2.795	68,00 2.677	68,00 2.677	57,00 2.244	65,00 2.559	*
18	115,00 4.528	54,00 2.126	76,00 2.992	76,00 2.992	72,00 2.835	72,00 2.835	59,00 2.323	65,00 2.559	74,00 2.913
20	114,00 4.488	54,00 2.126	81,00 3.190	82,00 3.228	77,00 3.031	78,00 3.071	60,00 2.362	68,00 2.677	80,00 3.150
22	114,00 4.488	54,00 2.126	81,00 3.190	119,00 4.685	78,00 3.071	78,00 3.071	63,00 2.480	68,00 2.677	80,00 3.150
24	109,00 4.291	54,00 2.126	89,00 3.504	90,00 3.543	86,00 3.386	86,00 3.386	60,00 2.362	68,00 2.677	80,00 3.150
28	119,00 4.685	54,00 2.126	88,00 3.465	89,00 3.504	85,00 3.346	85,00 3.346	63,00 2.480	67,00 2.638	81,00 3.189
32	116,00 4.567	54,00 2.126	98,00 3.858	101,00 3.976	95,00 3.740	95,00 3.740	62,00 2.441	67,00 2.638	80,00 3.150
36	112,00 4.409	54,00 2.126	104,00 4.094	105,00 4.134	101,00 3.976	101,00 3.976	67,00 2.638	68,00 2.677	80,00 3.150
40	N/A	54,00 2.126	111,00 4.370	112,00 4.409	107,00 4.213	107,00 4.213	68,00 2.677	68,00 2.677	80,00 3.150

* Please consult factory for availability.

ABCIRH '06' Style Connector & Accessory cont.

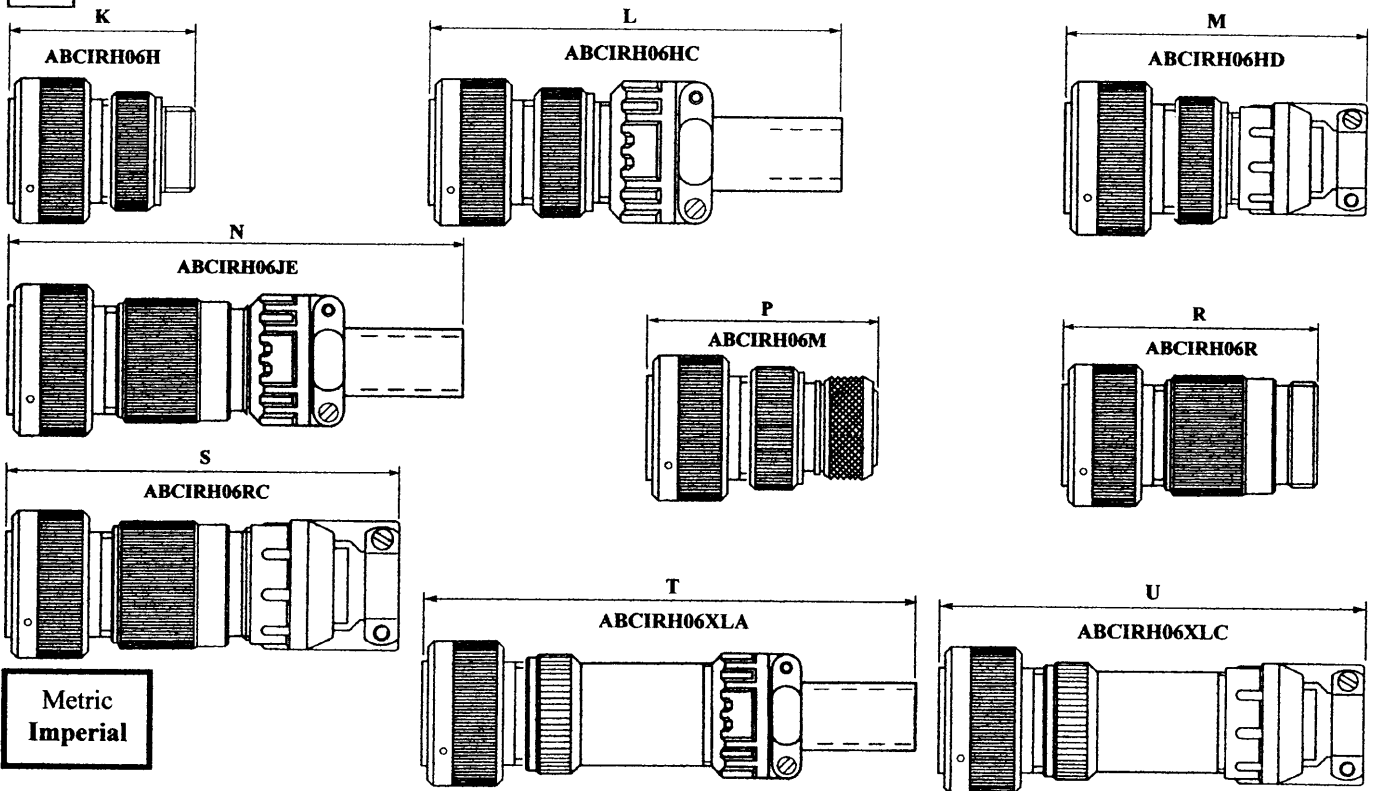

Metric
Imperial

Shell Size	K	L	M	N	P	R	S	T	U
10SL	50,00 1.969	122,00 4.803	81,00 3.189	121,00 4.764	53,00 2.087	51,00 2.008	82,00 3.228	140,00 5.512	101,00 3.976
14S	50,00 1.969	119,00 4.685	81,00 3.189	118,00 4.646	56,00 2.205	51,00 2.008	82,00 3.228	137,00 5.394	101,00 3.976
16S	50,00 1.969	120,00 4.724	81,00 3.189	115,00 4.528	56,00 2.205	51,00 2.008	82,00 3.228	134,00 5.276	101,00 3.976
16	57,00 2.244	123,00 4.843	88,00 3.465	124,00 4.882	63,00 2.480	60,00 2.362	91,00 3.583	152,00 5.984	121,00 4.764
18	59,00 2.323	124,00 4.882	92,00 3.622	127,00 5.000	66,00 2.598	66,00 2.598	99,00 3.898	149,00 5.866	121,00 4.764
20	59,00 2.323	120,00 4.724	92,00 3.622	123,00 4.843	66,00 2.598	66,00 2.598	99,00 3.898	145,00 5.709	121,00 4.764
22	59,00 2.323	120,00 4.724	92,00 3.622	123,00 4.843	66,00 2.598	66,00 2.598	99,00 3.898	145,00 5.709	121,00 4.764
24	59,00 2.323	107,00 4.213	95,00 3.740	123,00 4.843	66,00 2.598	69,00 2.717	105,00 4.134	142,00 5.591	124,00 4.882
28	59,00 2.323	107,00 4.213	95,00 3.740	124,00 4.882	65,00 2.559	70,00 2.756	106,00 4.173	149,00 5.866	131,00 5.157
32	58,00 2.283	106,00 4.173	100,00 3.937	120,00 4.724	65,00 2.559	69,00 2.717	111,00 4.370	146,00 5.748	137,00 5.394
36	58,00 2.283	106,00 4.173	107,00 4.213	117,00 4.606	65,00 2.559	69,00 2.717	117,00 4.606	143,00 5.630	144,00 5.669
40	58,00 2.283	103,00 4.055	107,00 4.213	114,00 4.488	65,00 2.559	70,00 2.756	112,00 4.409	140,00 5.512	144,00 5.669

Plug

Rubber Covered Coupling Nut

Style: ABCIRHP06T

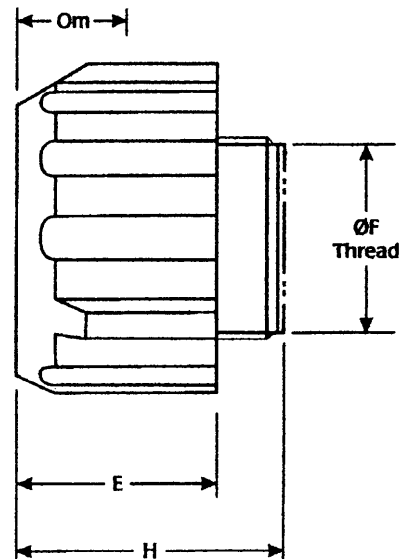
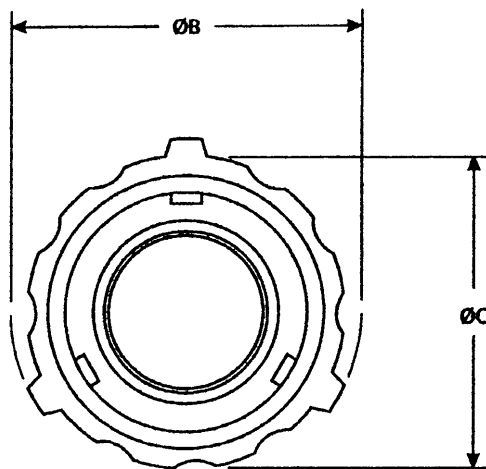

Metric
 Imperial

Shell Size	B Max	C Max	E Max	F Thread Dia. Class 2A	H Max	Om Min Overlap Mated
*10SL	33,50 1.319	28,50 1.122	19,40 0.764	5/8" x 24 UNEF	29,55 1.163	13,10 0.516
*14S	40,20 1.583	35,20 1.386	19,40 0.764	3/4" x 20 UNEF	29,55 1.163	13,10 0.516
*16S	43,88 1.726	38,90 1.531	19,40 0.764	7/8" x 20 UNEF	29,55 1.163	13,10 0.516
*16	43,88 1.726	38,90 1.531	27,10 1.067	7/8" x 20 UNEF	37,07 1.459	17,85 0.703
18	49,00 1.929	43,50 1.713	27,10 1.067	1" x 20 UNEF	37,07 1.459	17,85 0.703
20	51,50 2.026	46,00 1.811	27,10 1.067	1 1/8" x 18 UNEF	37,07 1.459	17,85 0.703
22	56,00 2.205	50,50 1.988	27,10 1.067	1 1/4" x 18 UNEF	37,07 1.459	17,85 0.703
24	60,00 2.362	54,00 2.126	27,10 1.067	1 3/8" x 18 UNEF	37,07 1.459	17,75 0.669
*28	67,00 2.638	61,00 2.402	27,10 1.067	1 5/8" x 18 UNEF	37,07 1.459	17,75 0.669
*32	76,00 2.992	67,60 2.661	27,10 1.067	1 7/8" x 16 UN	37,07 1.459	17,75 0.669
36	82,30 3.240	74,30 2.925	27,10 1.067	2 1/16" x 16 UNS	37,07 1.459	17,75 0.669
40	88,00 3.465	80,00 3.150	27,10 1.067	2 5/16" x 16 UN	37,07 1.459	17,75 0.669

* Please consult factory for availability.

ABCIRH 'P06' Style Connector & Accessory

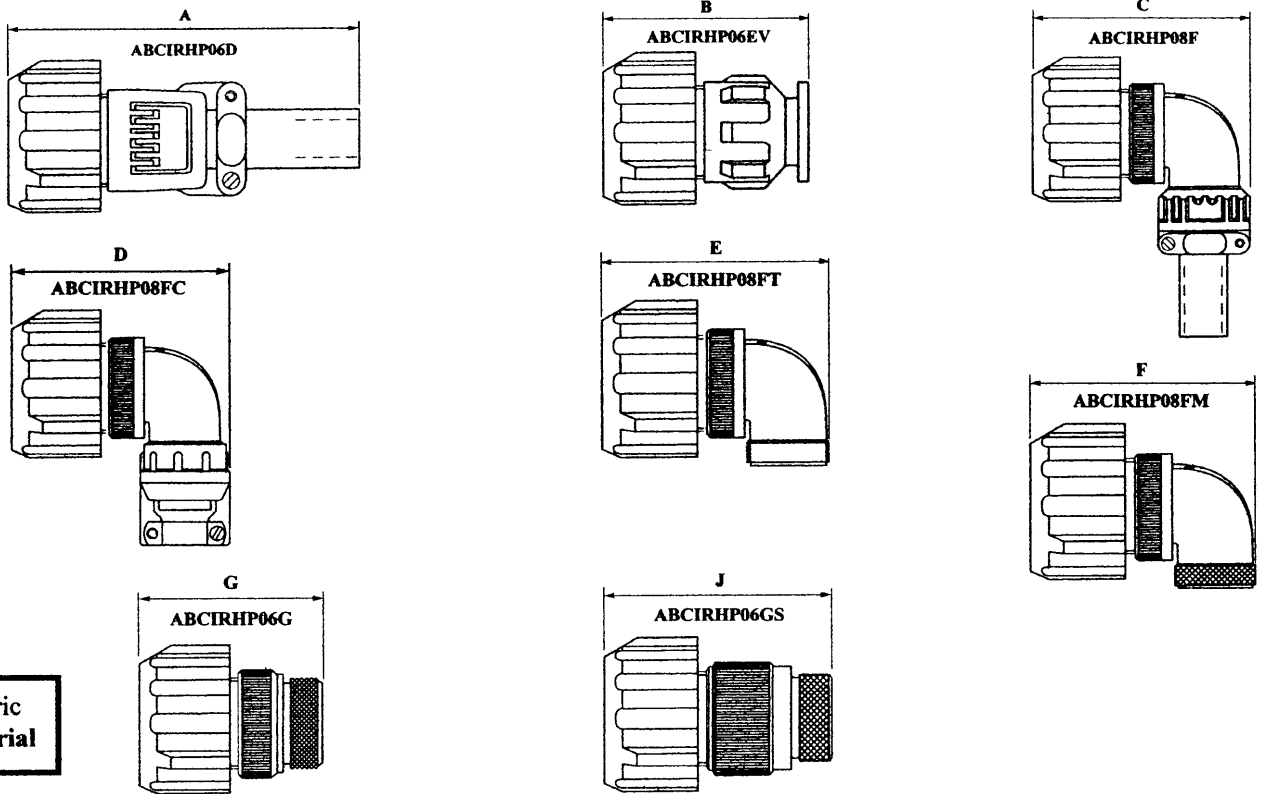

Shell Size	A	B	C	D	E	F	G	J
*10SL	109,00 4.291	44,00 1.732	58,00 2.283	58,00 2.283	55,00 2.165	55,00 2.165	50,00 1.969	*
*14S	108,00 4.252	44,00 1.732	61,00 2.402	61,00 2.402	57,00 2.244	57,00 2.244	50,00 1.969	*
*16S	105,00 4.134	44,00 1.732	65,00 2.559	65,00 2.559	61,00 2.402	61,00 2.402	50,00 1.969	*
*16	112,00 4.409	55,00 2.165	72,00 2.835	72,00 2.835	68,00 2.677	68,00 2.677	58,00 2.283	*
18	116,00 4.567	55,00 2.165	77,00 3.031	77,00 3.031	73,00 2.874	73,00 2.874	60,00 2.362	75,00 2.953
20	115,00 4.528	55,00 2.165	82,00 3.228	83,00 3.268	78,00 3.071	78,00 3.071	61,00 2.402	81,00 3.189
22	115,00 4.528	55,00 2.165	82,00 3.228	83,00 3.268	78,00 3.071	78,00 3.071	64,00 2.520	81,00 3.189
24	109,00 4.291	55,00 2.165	90,00 3.543	90,00 3.543	86,00 3.386	86,00 3.386	61,00 2.402	81,00 3.189
*28	119,00 4.685	55,00 2.165	89,00 3.504	89,00 3.504	85,00 3.346	85,00 3.346	64,00 2.520	82,00 3.228
*32	116,00 4.567	55,00 2.165	99,00 3.898	102,00 4.016	95,00 3.740	95,00 3.740	62,00 2.441	81,00 3.189
36	113,00 4.449	55,00 2.165	105,00 4.134	106,00 4.173	101,00 3.976	101,00 3.976	67,00 2.638	81,00 3.189
40	NA	55,00 2.165	112,00 4.409	112,00 4.409	108,00 4.252	108,00 4.252	69,00 2.717	81,00 3.189

* Please consult factory for availability.

ABCIRH 'P06' Style Connector & Accessory cont.

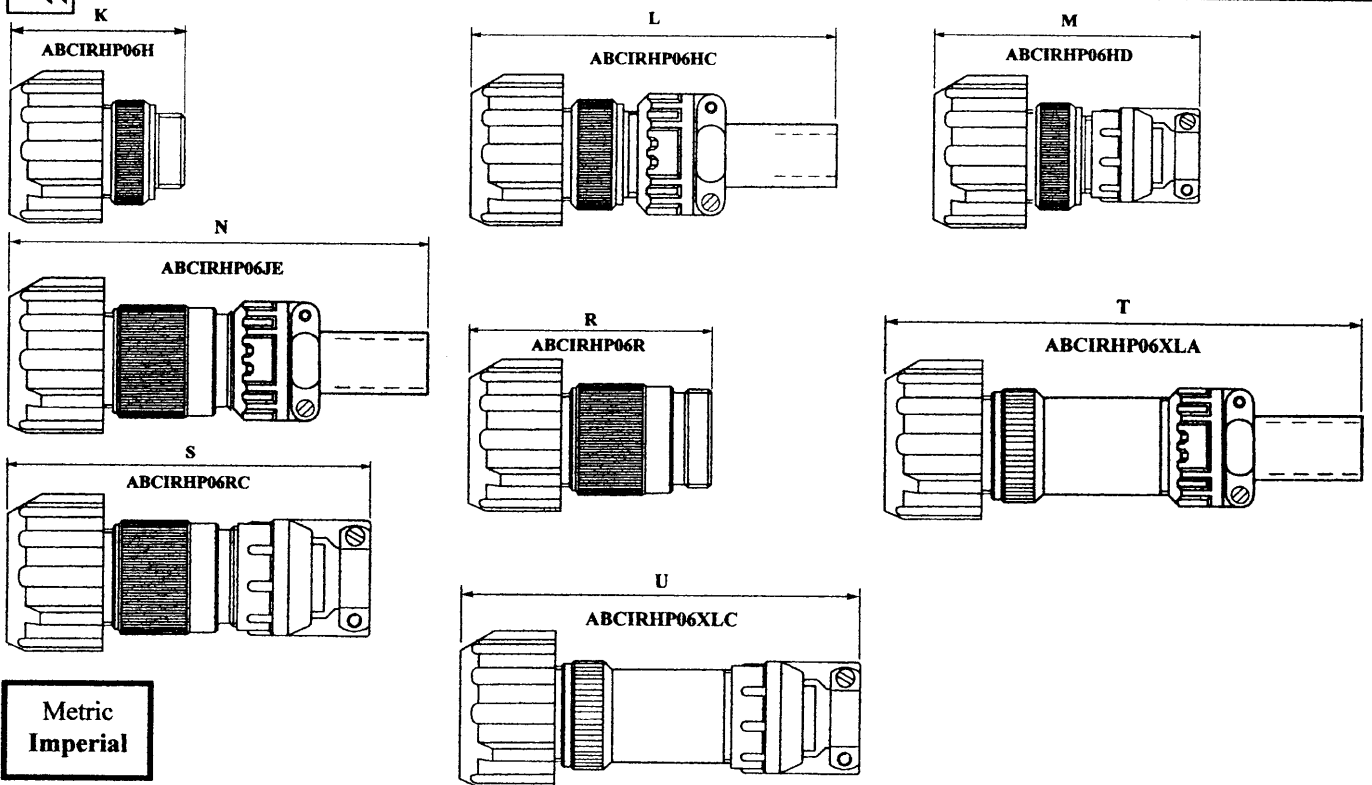

Metric
Imperial

Shell Size	K	L	M	N	R	S	T	U
*10SL	51,00 2.008	123,00 4.843	81,00 3.189	122,00 4.803	52,00 2.047	83,00 3.268	140,00 5.512	102,00 4.016
*14S	51,00 2.008	119,00 4.685	81,00 3.189	119,00 4.685	52,00 2.047	83,00 3.268	138,00 5.433	102,00 4.016
*16S	51,00 2.008	121,00 4.764	81,00 3.189	115,00 4.528	52,00 2.047	83,00 3.268	135,00 5.315	102,00 4.016
*16	58,00 2.283	124,00 4.882	89,00 3.504	124,00 4.882	61,00 2.402	92,00 3.622	152,00 5.984	121,00 4.764
18	60,00 2.362	125,00 4.921	93,00 3.661	127,00 5.000	67,00 2.638	99,00 3.898	149,00 5.866	121,00 4.764
20	60,00 2.362	121,00 4.764	93,00 3.661	124,00 4.882	67,00 2.638	99,00 3.898	146,00 5.748	121,00 4.764
22	60,00 2.362	121,00 4.764	93,00 3.661	124,00 4.882	67,00 2.638	99,00 3.898	146,00 5.748	121,00 4.764
24	60,00 2.362	108,00 4.252	96,00 3.780	124,00 4.882	70,00 2.756	106,00 4.173	143,00 5.630	125,00 4.921
*28	60,00 2.362	108,00 4.252	96,00 3.780	125,00 4.921	71,00 2.795	106,00 4.173	150,00 5.906	132,00 5.197
*32	59,00 2.323	107,00 4.213	101,00 3.976	121,00 4.764	70,00 2.756	112,00 4.409	147,00 5.787	138,00 5.433
36	59,00 2.323	107,00 4.213	107,00 4.213	117,00 4.606	70,00 2.756	118,00 4.646	144,00 5.669	144,00 5.669
40	59,00 2.323	104,00 4.094	107,00 4.213	116,00 4.567	71,00 2.795	113,00 4.449	140,00 5.512	144,00 5.669

* Please consult factory for availability.



ABCIRH Shell Size 49. Plug With Conduit Adaptor
Rubber Covered Coupling Nut
Style: ABCIRHP06GGL or GGS.....

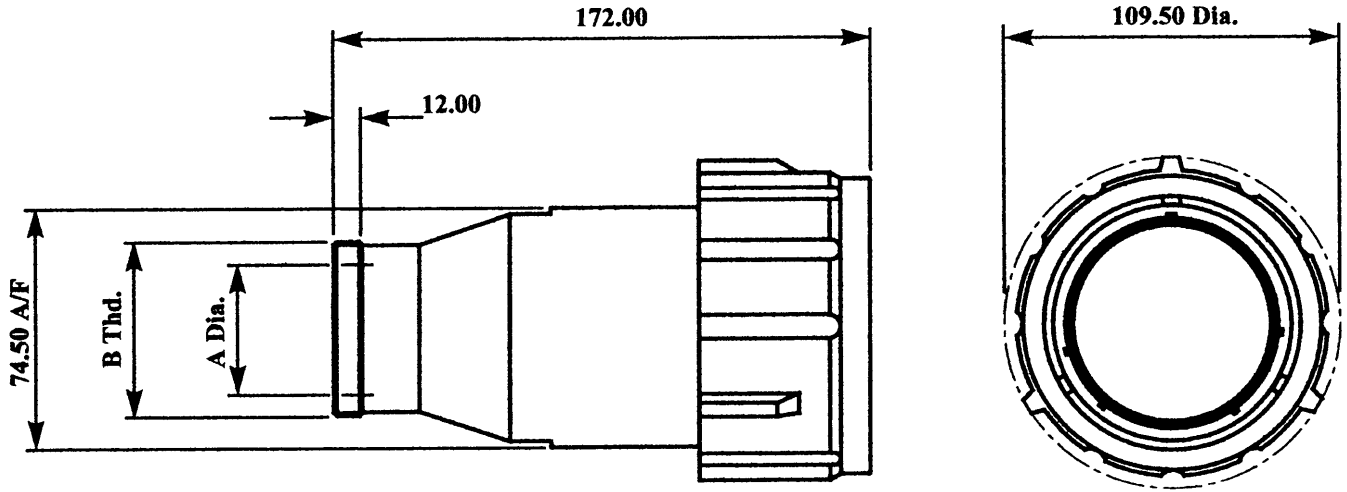

Metric
 Imperial

Connector Style	A Dia. Max.	B Thread
ABCIRHP06GGL.....	43,50 1.713	2 1/4" x 16 UN-2A
ABCIRHP06GGS.....	29,00 1.142	1 3/4" x 18 UNEF-2A

ABCIRH 'P06' Style Connector & Accessory cont.

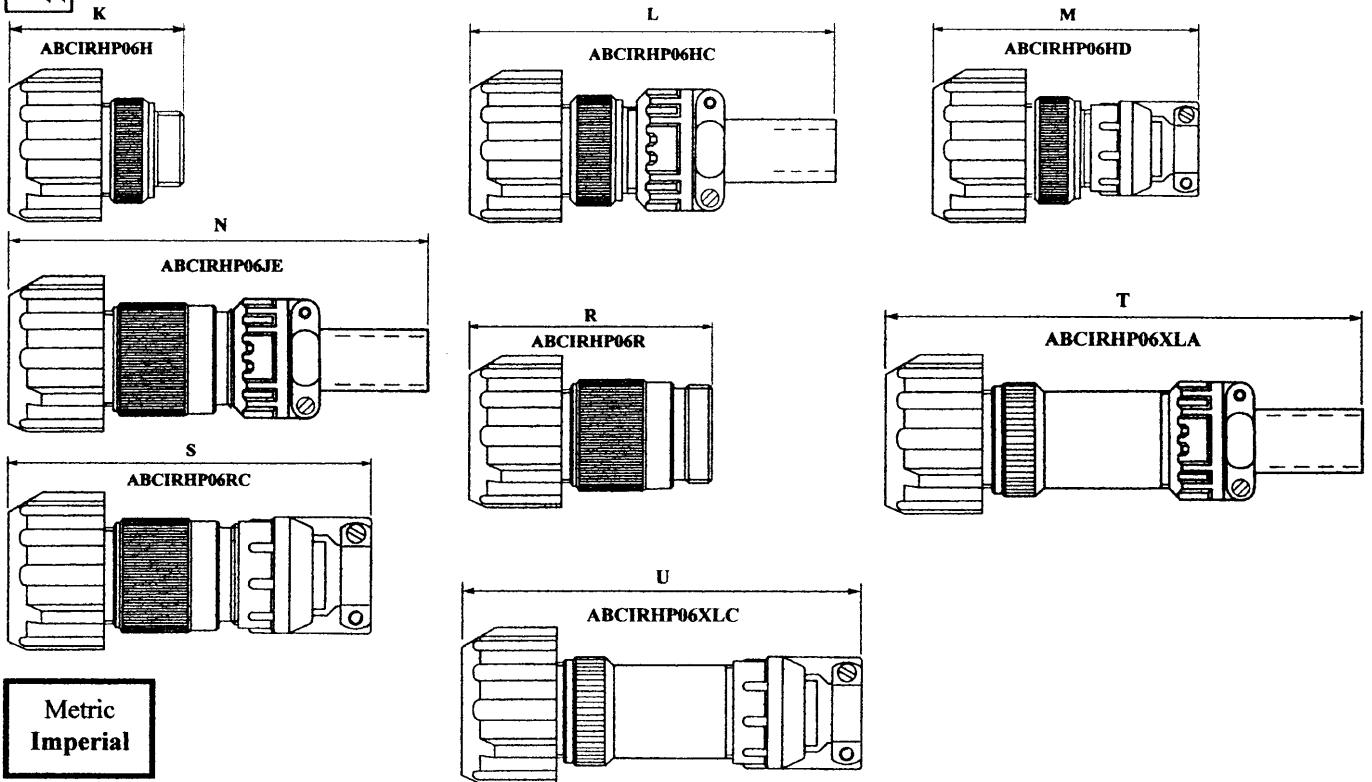

Metric
Imperial

Shell Size	K	L	M	N	R	S	T	U
*10SL	51,00 2.008	123,00 4.843	81,00 3.189	122,00 4.803	52,00 2.047	83,00 3.268	140,00 5.512	102,00 4.016
*14S	51,00 2.008	119,00 4.685	81,00 3.189	119,00 4.685	52,00 2.047	83,00 3.268	138,00 5.433	102,00 4.016
*16S	51,00 2.008	121,00 4.764	81,00 3.189	115,00 4.528	52,00 2.047	83,00 3.268	135,00 5.315	102,00 4.016
*16	58,00 2.283	124,00 4.882	89,00 3.504	124,00 4.882	61,00 2.402	92,00 3.622	152,00 5.984	121,00 4.764
18	60,00 2.362	125,00 4.921	93,00 3.661	127,00 5.000	67,00 2.638	99,00 3.898	149,00 5.866	121,00 4.764
20	60,00 2.362	121,00 4.764	93,00 3.661	124,00 4.882	67,00 2.638	99,00 3.898	146,00 5.748	121,00 4.764
22	60,00 2.362	121,00 4.764	93,00 3.661	124,00 4.882	67,00 2.638	99,00 3.898	146,00 5.748	121,00 4.764
24	60,00 2.362	108,00 4.252	96,00 3.780	124,00 4.882	70,00 2.756	106,00 4.173	143,00 5.630	125,00 4.921
*28	60,00 2.362	108,00 4.252	96,00 3.780	125,00 4.921	71,00 2.795	106,00 4.173	150,00 5.906	132,00 5.197
*32	59,00 2.323	107,00 4.213	101,00 3.976	121,00 4.764	70,00 2.756	112,00 4.409	147,00 5.787	138,00 5.433
36	59,00 2.323	107,00 4.213	107,00 4.213	117,00 4.606	70,00 2.756	118,00 4.646	144,00 5.669	144,00 5.669
40	59,00 2.323	104,00 4.094	107,00 4.213	116,00 4.567	71,00 2.795	113,00 4.449	140,00 5.512	144,00 5.669

* Please consult factory for availability.

Through Bulkhead Receptacle

Style: ABCIRH07/ABCIRH07...M6

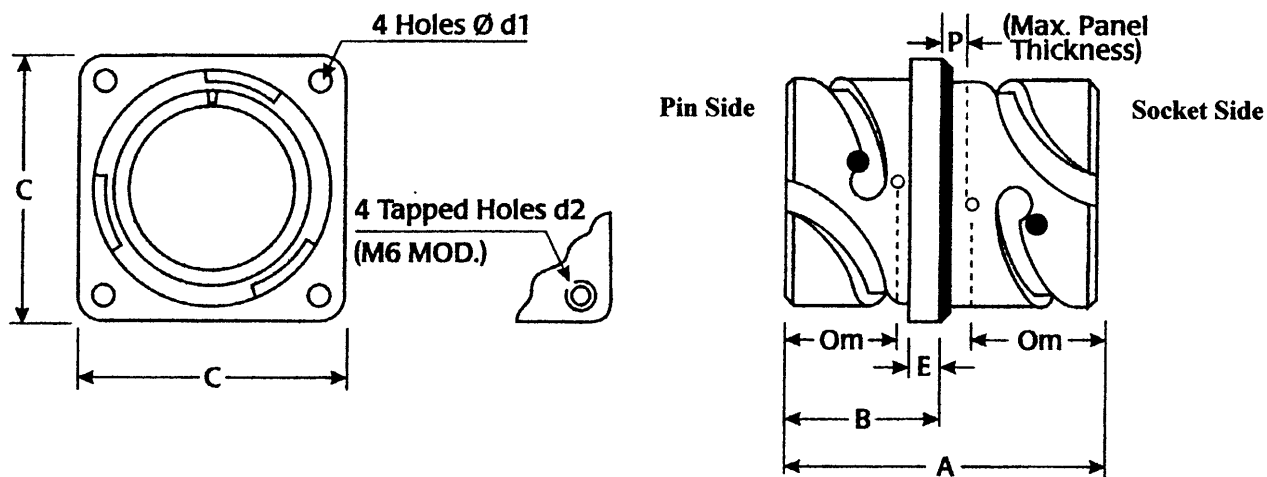

Metric
Imperial

See page 82 for panel mounting details

Note. Maximum panel thickness when using cap head screws.
When using countersunk screws, maximum panel thickness = 7.5 mm

Shell Size	A Max	B Max	C Max	d1 +0,2 -0 +0.008-0	d2 Thread	E Max	P See Note	Om Min Overlap Mated
10SL	38,20 1.504	17,60 0.693	25,70 1.012	3,20 0.126	M4	3,00 0.118	3,30 0.130	11,10 0.437
14S	38,20 1.504	18,00 0.709	30,30 1.193	3,20 0.126	M4	3,40 0.134	3,30 0.130	11,10 0.437
16S	38,20 1.504	18,00 0.709	32,80 1.291	3,20 0.123	M4	3,40 0.134	3,30 0.130	11,10 0.437
16	52,10 2.051	22,80 0.898	32,80 1.291	3,20 0.126	M4	3,40 0.134	3,30 0.130	15,85 0.624
18	52,10 2.051	23,60 0.929	35,30 1.390	3,20 0.126	M4	4,20 0.165	3,30 0.130	15,85 0.624
20	52,10 2.051	23,60 0.929	38,30 1.508	3,20 0.126	M4	4,20 0.165	3,30 0.130	15,85 0.624
22	52,10 2.051	23,60 0.929	41,30 1.626	3,20 0.126	M4	4,20 0.165	3,30 0.130	15,75 0.620
24	52,10 2.051	25,20 0.992	44,80 1.764	3,70 0.146	M4	4,20 0.165	3,30 0.130	15,75 0.620
28	52,10 2.051	25,20 0.992	51,10 2.012	3,70 0.146	M5	4,20 0.165	3,30 0.130	15,75 0.620
32	52,10 2.051	26,80 1.055	57,30 2.256	4,30 0.169	M5	4,20 0.165	3,30 0.130	15,75 0.620
36	52,10 2.051	26,80 1.055	63,80 2.512	4,30 0.169	M5	4,20 0.165	3,30 0.130	15,75 0.620
40	52,10 2.051	26,80 1.055	70,20 2.764	4,30 0.169	M5	4,20 0.165	3,30 0.130	15,75 0.620



Single Hole Mounting Receptacle
Rear Mounted (No Accessory Thread)
Style: ABCIRH09A

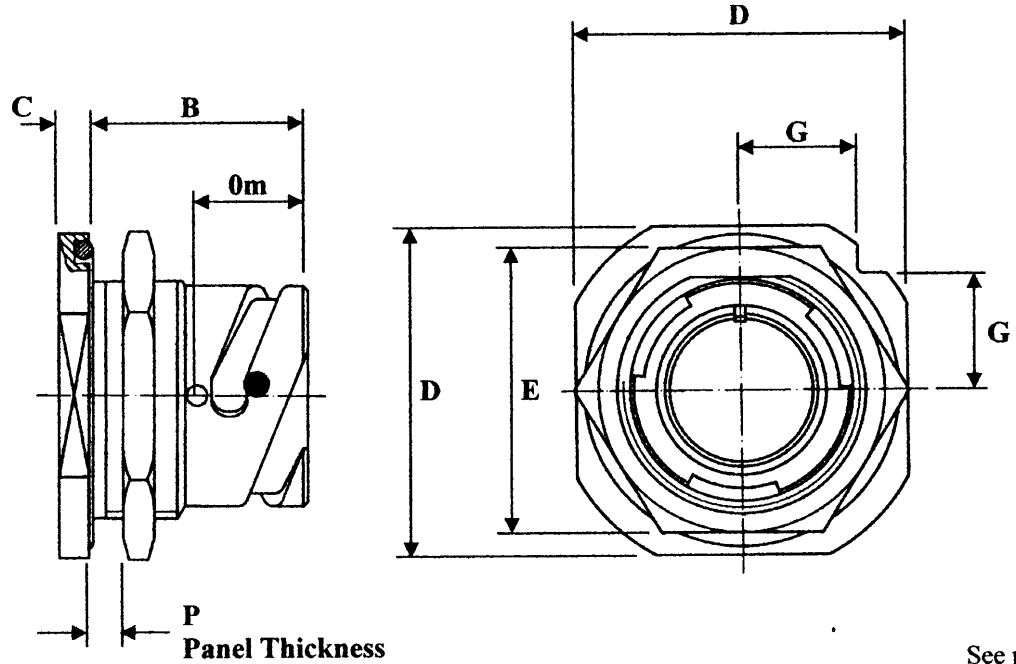

Metric
Imperial

See page 83 for panel mounting details

Shell Size	B	C	D Max	E	G	P		Om Min Overlap Mated
						Min	Max	
10SL	24,50 0.965	4,00 0.157	32,05 1.262	27,00 1.063	11,20 0.441	2,40 0.094	5,20 0.205	11,10 0.437
14S	26,80 1.055	4,80 0.189	41,55 1.636	33,00 1.299	14,60 0.575	2,40 0.094	7,50 0.295	11,10 0.437
16S	26,80 1.055	4,80 0.189	44,65 1.758	38,10 1.500	15,70 0.618	2,40 0.094	7,50 0.295	11,10 0.437
16	32,10 1.264	4,80 0.189	44,65 1.758	38,10 1.500	15,70 0.618	2,40 0.094	7,50 0.295	15,85 0.624
18	33,70 1.327	4,80 0.189	47,85 1.884	39,70 1.563	16,80 0.661	2,40 0.094	9,00 0.354	15,85 0.624
20	33,70 1.327	4,80 0.189	51,05 2.034	44,00 1.732	18,00 0.709	2,40 0.094	9,00 0.354	15,85 0.624
22	33,70 1.327	4,80 0.189	54,45 2.144	46,00 1.811	20,20 0.795	2,40 0.094	9,10 0.358	15,75 0.620
24	33,70 1.327	4,80 0.189	57,45 2.262	50,80 2.000	20,20 0.795	2,40 0.094	9,10 0.358	15,75 0.620
28	35,20 1.386	5,60 0.220	63,75 2.510	55,00 2.165	22,50 0.886	2,40 0.094	8,50 0.335	15,75 0.620
32	35,20 1.386	5,60 0.220	70,05 2.758	62,00 2.441	24,70 0.972	2,40 0.094	8,50 0.335	15,75 0.620
36	35,20 1.386	5,60 0.220	76,45 3.010	71,00 2.795	26,90 1.059	2,40 0.094	8,30 0.327	15,75 0.620
40	35,20 1.386	5,60 0.220	83,75 3.297	75,00 2.953	29,60 1.165	2,40 0.094	8,30 0.327	15,75 0.620



Single Hole Mounting Receptacle
Rear Mounted (With Accessory Thread)
Style: ABCIRH09T

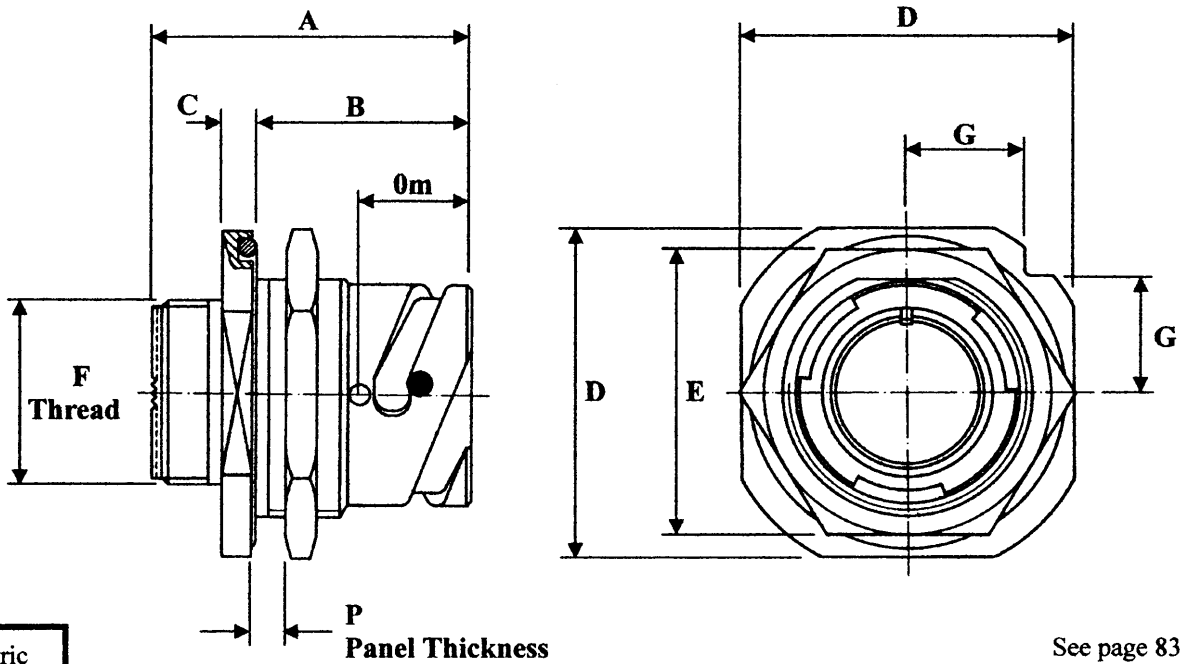

Metric
Imperial

See page 83 for panel mounting details

Shell Size	A Max	B	C	D Max	E	F Thread Dia. Class 2A	G	P		Om Min Overlap Mated
								Min	Max	
10SL	36,45 1.435	24,50 0.965	4,00 0.157	32,05 1.262	27,00 1.063	5/8" x 24 UNEF	11,20 0.441	2,40 0.094	5,20 0.205	11,10 0.437
14S	39,15 1.541	26,80 1.055	4,80 0.189	41,55 1.636	33,00 1.299	3/4" x 20 UNEF	14,60 0.575	2,40 0.094	7,50 0.295	11,10 0.437
16S	39,15 1.541	26,80 1.055	4,80 0.189	44,65 1.758	38,10 1.500	7/8" x 20 UNEF	15,70 0.618	2,40 0.094	7,50 0.295	11,10 0.437
16	48,75 1.919	32,10 1.264	4,80 0.189	44,65 1.758	38,10 1.500	7/8" x 20 UNEF	15,70 0.618	2,40 0.094	7,50 0.295	15,85 0.624
18	49,55 1.951	33,70 1.327	4,80 0.189	47,85 1.884	39,70 1.563	1" x 20 UNEF	16,80 0.661	2,40 0.094	9,00 0.354	15,85 0.624
20	49,55 1.951	33,70 1.327	4,80 0.189	51,05 2.034	44,00 1.732	1 1/8" x 18 UNEF	18,00 0.709	2,40 0.094	9,00 0.354	15,85 0.624
22	49,55 1.951	33,70 1.327	4,80 0.189	54,45 2.144	46,00 1.811	1 1/4" x 18 UNEF	20,20 0.795	2,40 0.094	9,10 0.358	15,75 0.620
24	49,55 1.951	33,70 1.327	4,80 0.189	57,45 2.262	50,80 2.000	1 3/8" x 18 UNEF	20,20 0.795	2,40 0.094	9,10 0.358	15,75 0.620
28	52,15 2.053	35,20 1.386	5,60 0.220	63,75 2.510	55,00 2.165	1 5/8" x 18 UNEF	22,50 0.886	2,40 0.094	8,50 0.335	15,75 0.620
32	52,15 2.053	35,20 1.386	5,60 0.220	70,05 2.758	62,00 2.441	1 7/8" x 16 UN	24,70 0.972	2,40 0.094	8,50 0.335	15,75 0.620
36	52,15 2.053	35,20 1.386	5,60 0.220	76,45 3.010	71,00 2.795	2 1/16" x 16 UNS	26,90 1.059	2,40 0.094	8,30 0.327	15,75 0.620
40	52,15 2.053	35,20 1.386	5,60 0.220	83,75 3.297	75,00 2.953	2 5/16" x 16 UN	29,60 1.165	2,40 0.094	8,30 0.327	15,75 0.620

ABCIRH '09' Style Connector & Accessory

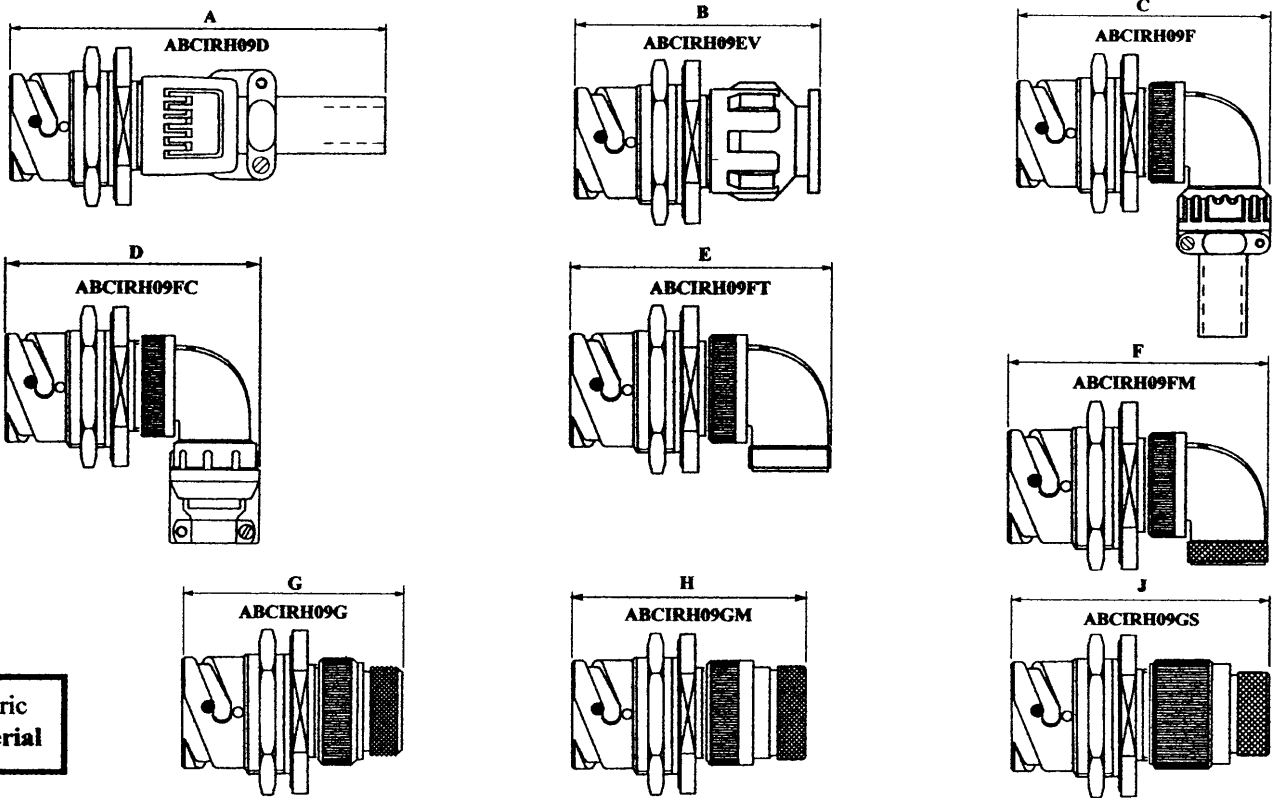

Metric
Imperial

Shell Size	A	B	C	D	E	F	G	H	J
10SL	116,00 4.567	51,00 2.008	65,00 2.560	65,00 2.560	61,00 2.402	61,00 2.402	57,00 2.244	61,00 2.402	*
14S	117,00 4.606	54,00 2.126	70,00 2.756	71,00 2.795	67,00 2.638	67,00 2.638	60,00 2.362	64,00 2.520	*
16S	114,00 4.488	54,00 2.126	72,00 2.835	74,00 2.913	70,00 2.756	70,00 2.756	60,00 2.362	64,00 2.520	*
16	124,00 4.882	67,00 2.638	84,00 3.307	83,00 3.268	78,00 3.071	80,00 3.150	69,00 2.717	77,00 3.031	*
18	128,00 5.040	68,00 2.677	89,00 3.504	89,00 3.504	85,00 3.346	85,00 3.346	72,00 2.835	78,00 3.071	88,00 3.465
20	127,00 5.000	68,00 2.677	94,00 3.700	95,00 3.740	91,00 3.583	91,00 3.583	73,00 2.875	82,00 3.228	93,00 3.661
22	127,00 5.000	68,00 2.677	94,00 3.700	96,00 3.780	91,00 3.583	91,00 3.583	76,00 2.992	82,00 3.228	94,00 3.700
24	122,00 4.803	68,00 2.677	102,00 4.016	103,00 4.055	99,00 3.898	99,00 3.898	73,00 2.875	82,00 3.228	94,00 3.700
28	135,00 5.315	70,00 2.756	104,00 4.094	105,00 4.134	101,00 3.976	101,00 3.976	79,00 3.110	83,00 3.268	97,00 3.700
32	131,00 5.157	70,00 2.756	114,00 4.488	117,00 4.606	111,00 4.370	111,00 4.370	77,00 3.031	83,00 3.268	96,00 3.780
36	128,00 5.040	70,00 2.756	120,00 4.724	121,00 4.764	117,00 4.606	117,00 4.606	83,00 3.268	84,00 3.307	96,00 3.780
40	NA	70,00 2.756	127,00 5.000	128,00 5.039	123,00 4.843	123,00 4.843	84,00 3.307	84,00 3.307	96,00 3.780

* Please consult factory for availability.

ABCIRH '09' Style Connector & Accessory cont.

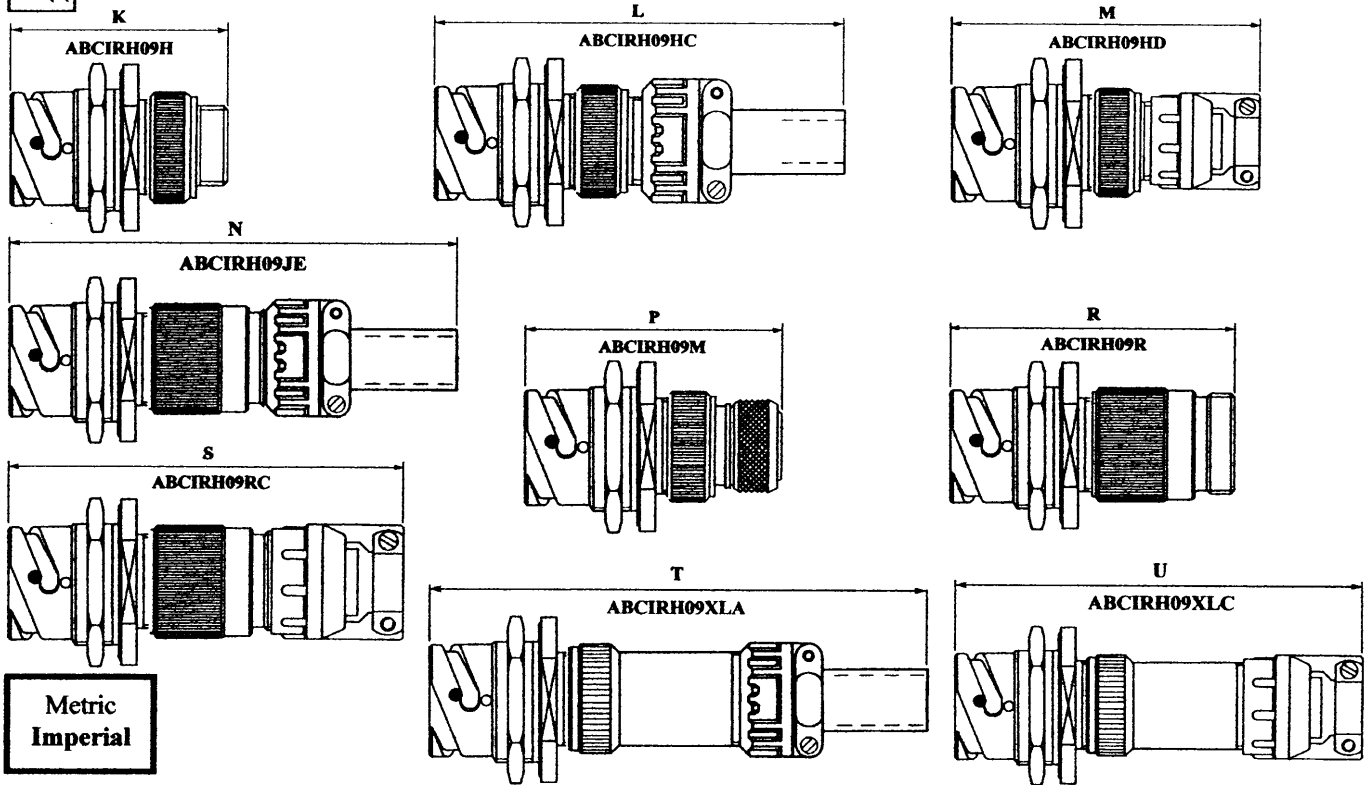

Metric
Imperial

Shell Size	K	L	M	N	P	R	S	T	U
10SL	57,00 2.244	130,00 5.118	88,00 3.465	130,00 5.118	61,00 2.402	59,00 2.323	90,00 3.543	148,00 5.827	109,00 4.291
14S	60,00 2.362	129,00 5.079	91,00 3.583	128,00 5.039	66,00 2.598	61,00 2.402	92,00 3.622	147,00 5.787	112,00 4.409
16S	60,00 2.362	131,00 5.157	91,00 3.583	125,00 4.921	66,00 2.598	61,00 2.402	92,00 3.622	144,00 5.669	112,00 4.409
16	72,00 2.835	135,00 5.315	101,00 3.976	136,00 5.354	76,00 2.992	72,00 2.835	103,00 4.055	134,00 5.276	133,00 5.236
18	73,00 2.875	138,00 5.433	105,00 4.134	140,00 5.512	80,00 3.150	79,00 3.110	112,00 4.409	162,00 6.378	134,00 5.276
20	73,00 2.875	133,00 5.236	105,00 4.134	137,00 5.394	80,00 3.150	79,00 3.110	112,00 4.409	159,00 6.260	134,00 5.276
22	73,00 2.875	133,00 5.236	105,00 4.134	137,00 5.394	80,00 3.150	79,00 3.110	112,00 4.409	159,00 6.260	134,00 5.276
24	73,00 2.875	120,00 4.724	108,00 4.252	137,00 5.394	80,00 3.150	79,00 3.110	112,00 4.409	159,00 6.260	134,00 5.276
28	75,00 2.953	123,00 4.843	112,00 4.409	140,00 5.512	81,00 3.189	86,00 3.386	121,00 4.764	165,00 6.496	147,00 5.787
32	74,00 2.913	122,00 4.803	116,00 4.567	136,00 5.354	81,00 3.189	85,00 3.346	127,00 5.000	162,00 6.378	153,00 6.024
36	74,00 2.913	122,00 4.803	122,00 4.803	133,00 5.236	81,00 3.189	85,00 3.346	133,00 5.236	159,00 6.260	159,00 6.260
40	74,00 2.913	119,00 4.685	123,00 4.843	131,00 5.157	81,00 3.189	86,00 3.386	128,00 5.039	155,00 6.102	159,00 6.260

Panel Mounted Plug (No Accessory Thread)

Style: ABCIRH12A/ABCIRH12A...M6

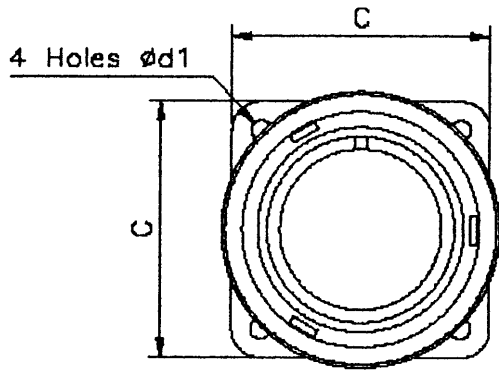

4 Tapped Holes $\varnothing d2$
(M6 MOD.)

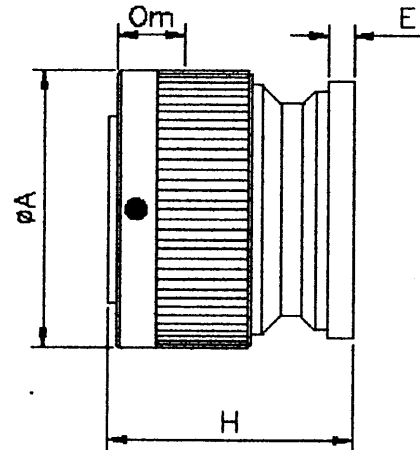

Metric
Imperial

See page 82 for panel
mounting details

Shell Size	A Max.	C Max.	d1 +0.2, -0 mm	d2 Thread	E Max.	H Max.	O_m Mim Overlap, Mated
10SL	24,20 0.953	25,70 1.012	3,20 0.126	M4	3,00 0.118	28,10 1.106	11,10 0.437
14S	30,60 1.205	30,30 1.193	3,20 0.126	M4	3,40 0.134	28,10 1.106	11,10 0.437
16S	33,40 1.315	32,80 1.291	3,20 0.126	M4	3,40 0.134	28,10 1.106	11,10 0.437
16	33,40 1.315	32,80 1.291	3,20 0.126	M4	3,40 0.134	37,60 1.480	15,85 0.624
18	37,30 1.469	35,30 1.390	3,20 0.126	M4	4,20 0.165	38,60 1.519	15,85 0.624
20	40,70 1.602	38,30 1.508	3,20 0.126	M4	4,20 0.165	38,60 1.519	15,85 0.624
22	44,20 1.740	41,30 1.626	3,20 0.126	M4	4,20 0.165	38,60 1.519	15,85 0.624
24	47,70 1.878	44,80 1.764	3,20 0.126	M4	4,20 0.165	41,00 1.614	15,75 0.620
28	54,50 2.146	51,10 2.012	3,20 0.126	M5	4,20 0.165	41,80 1.646	15,75 0.620
32	61,40 2.417	57,30 2.256	4,30 0.169	M5	4,20 0.165	45,00 1.772	15,75 0.620
36	68,00 2.677	63,80 2.512	4,30 0.169	M5	4,20 0.165	45,00 1.772	15,75 0.620
40	74,00 2.913	70,20 2.764	4,30 0.169	M5	4,20 0.165	45,00 1.772	15,75 0.620

Conduit Adaptor With Braid Screen Trap - No Grommet

Accessory Type 'RM'

Style: ABB - ** - CRA

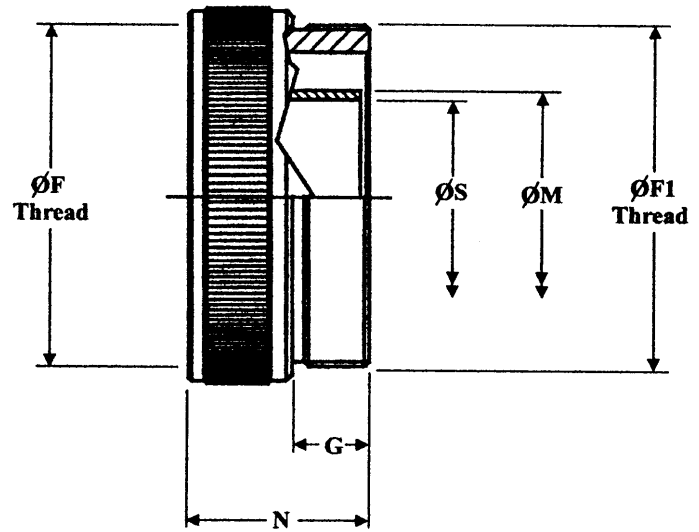
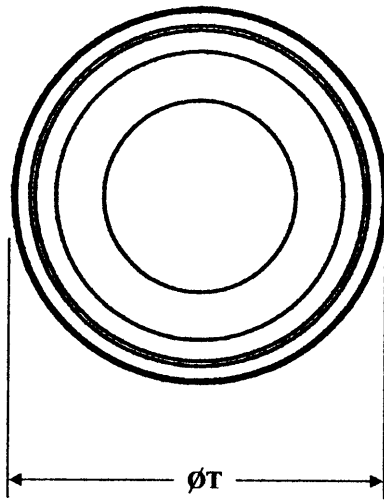

Metric
Imperial

Note.
This accessory can only be used in conjunction with style 'CCA', 'H' or 'FT' adaptor.

How to order:
ABB - ** - CRA
Shell size _____

Shell Size	F Thread Dia. Class 2B	F1 Thread Dia. Class 2A	G Max	N Max	S Min	T Max	M Max
*10SL	-	-	-	-	-	-	-
14S	3/4" x 20 UNEF	7/8" x 20 UNEF	10,00 0.394	27,60 1.087	8,51 0.335	21,53 0.848	11,71 0.461
16S	7/8" x 20 UNEF	1" x 20 UNEF	10,00 0.394	27,60 1.087	9,74 0.383	25,50 1.004	13,10 0.516
16	7/8" x 20 UNEF	1" x 20 UNEF	11,00 0.433	30,60 1.205	9,74 0.383	25,50 1.004	13,10 0.516
18	1" x 20 UNEF	1 3/16" x 18 UNEF	11,00 0.433	30,60 1.205	12,90 0.508	29,10 1.146	16,26 0.640
20	1 3/16" x 18 UNEF	1 7/16" x 18 UNEF	11,00 0.433	30,60 1.205	18,23 0.718	35,45 1.396	21,51 0.847
22	1 3/16" x 18 UNEF	1 7/16" x 18 UNEF	11,00 0.433	30,60 1.205	18,23 0.718	35,45 1.396	21,51 0.847
24	1 7/16" x 18 UNEF	1 3/4" x 18 UNS	11,00 0.433	30,60 1.205	25,93 1.021	43,60 1.717	29,21 1.150
28	1 7/16" x 18 UNEF	1 3/4" x 18 UNS	11,00 0.433	30,60 1.205	25,93 1.021	43,60 1.717	29,21 1.150
32	1 3/4" x 18 UNS	1 3/4" x 18 UNS	13,00 0.512	30,60 1.205	25,93 1.021	49,55 1.951	29,10 1.146
36	2" x 18 UNS	2" x 18 UNS	13,00 0.512	30,60 1.205	32,00 1.260	55,90 2.201	35,19 1.385
40	2 1/4" x 16 UN	2 1/4" x 16 UN	13,00 0.512	30,60 1.205	32,33 1.273	63,10 2.484	35,60 1.402

* Please consult factory for availability.

Non-Locking Cable Clamp With Grommet & Follower

Accessory Type 'D'

Style: ABBH - ** - ** - OCN - F80

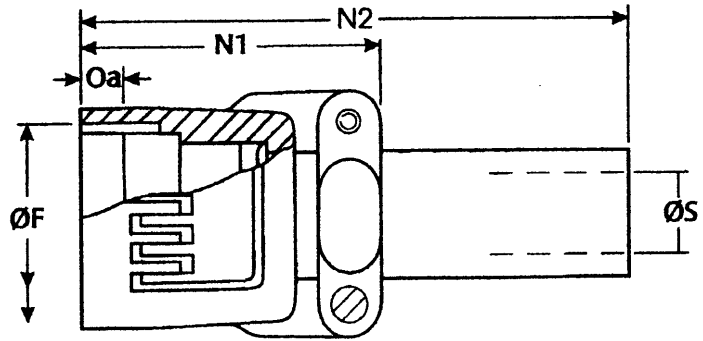
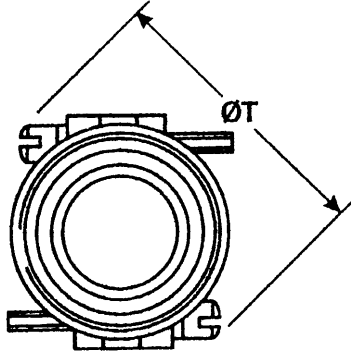

How to order:

ABBH - ** - ** - OCN - F80

Shell size

Contact arrangement

Metric
Imperial

Shell Size	F Thread Dia. Class 2B	N1 Max	N2 Max	S Min/Max	T Max	Oa Min Overlap Accessory
10SL	5/8" x 24 UNEF	36,42 1.434	86,68 3.413	3,68/5,76 0.145/0.227	35,15 1.384	7,00 0.276
14S	3/4" x 20 UNEF	27,41 1.079	85,04 3.348	4,62/8,10 0.182/0.319	39,88 1.570	7,00 0.276
16S	7/8" x 20 UNEF	27,41 1.079	81,99 3.228	7,82/11,30 0.308/0.444	41,45 1.632	7,00 0.276
16	7/8" x 20 UNEF	27,41 1.079	81,99 3.228	7,82/11,30 0.308/0.444	41,45 1.632	7,00 0.276
18	1" x 20 UNEF	44,68 1.759	85,55 3.368	8,79/14,45 0.346/0.569	45,52 1.792	7,00 0.276
20	1 1/8" x 18 UNEF	44,68 1.759	84,61 3.331	10,54/16,00 0.415/0.632	49,63 1.954	7,00 0.276
22	1 1/4" x 18 UNEF	44,68 1.759	84,61 3.331	10,54/16,00 0.415/0.632	49,63 1.954	7,00 0.276
24	1 3/8" x 18 UNEF	44,68 1.759	79,20 3.118	14,55/19,23 0.573/0.757	56,29 2.216	7,00 0.276
28	1 5/8" x 18 UNEF	54,79 2.157	89,31 3.516	14,15/19,23 0.557/0.757	60,45 2.380	7,00 0.276
32	1 7/8" x 16 UN	54,79 2.157	86,13 3.390	19,18/23,98 0.755/0.944	68,43 2.694	7,00 0.276
36	2 1/16" x 16 UNS	54,79 2.157	82,98 3.267	24,51/31,93 0.965/1.257	71,68 2.822	7,00 0.276

Non-Locking Grommet Nut With Grommet & Follower

Accessory Type 'EV'

Style: ABBH - ** - ** - EV - F80

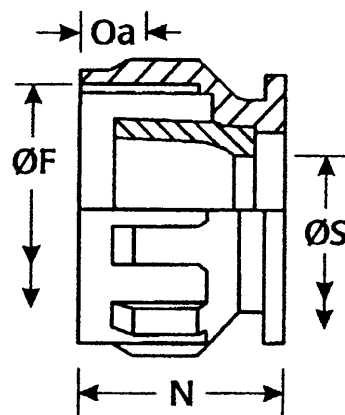
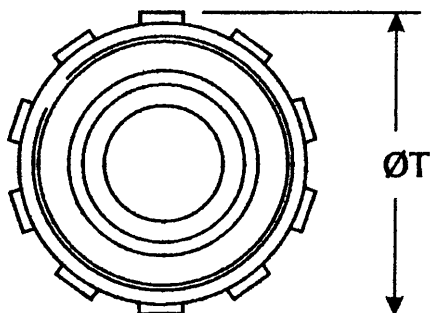

Metric
 Imperial

How to order:
ABBH - ** - ** - EV - F80
 Shell size _____
 Contact arrangement _____

Shell Size	T Max	F Thread Dia. Class 2B	N Max	S Min	Oa Min Overlap Accessory
10SL	21,60 0.850	5/8" x 24 UNEF	20,83 0.820	8,60 0.339	6,10 0.240
14S	24,80 0.976	3/4" x 20 UNEF	20,83 0.820	11,10 0.437	6,10 0.240
16S	28,70 1.130	7/8" x 20 UNEF	20,83 0.820	14,30 0.563	6,10 0.240
16	28,70 1.130	7/8" x 20 UNEF	25,53 1.005	14,30 0.563	7,60 0.300
18	31,90 1.256	1" x 20 UNEF	25,53 1.005	16,70 0.657	7,60 0.300
20	34,90 1.374	1 1/8" x 18 UNEF	25,53 1.005	19,80 0.780	7,60 0.300
22	38,20 1.504	1 1/4" x 18 UNEF	25,53 1.005	21,34 0.840	7,60 0.300
24	41,40 1.630	1 3/8" x 18 UNEF	25,53 1.005	25,40 1.000	7,60 0.300
28	47,80 1.882	1 5/8" x 18 UNEF	25,53 1.005	30,13 1.186	7,60 0.300
32	54,10 2.130	1 7/8" x 16 UN	25,53 1.005	36,73 1.446	7,60 0.300
36	58,70 2.311	2 1/16" x 16 UNS	25,53 1.005	41,00 1.614	7,60 0.300
40	63,00 2.480	2 5/16" x 16 UN	25,64 1.009	45,90 1.807	7,60 0.300

Locking 90° Angled Outlet With Cable Clamp & Grommet

Accessory Type 'F'

Style: ABBH - ** - ** - F - F80

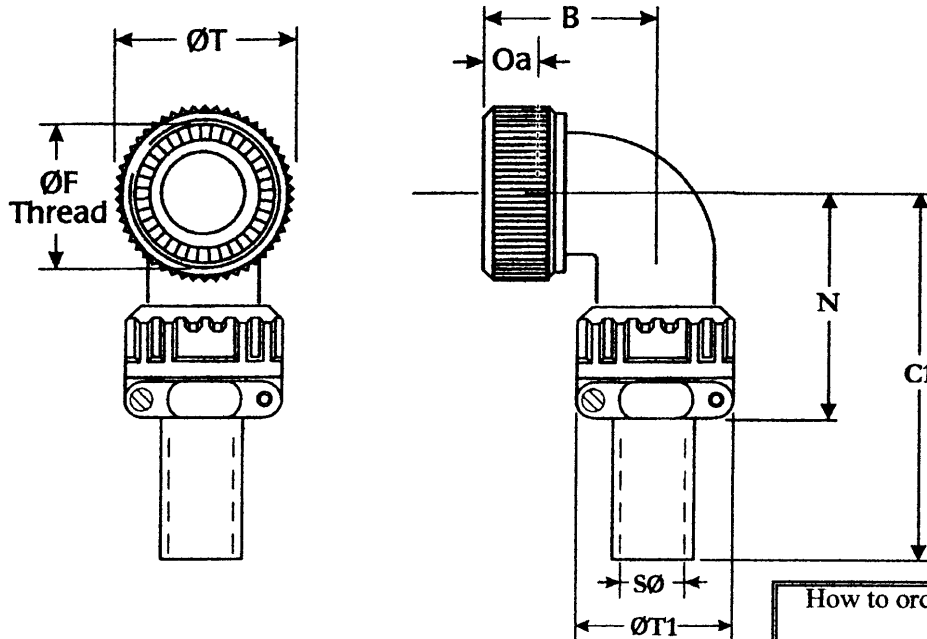

How to order:
ABBH - ** - ** - F - F80
 Shell size _____
 Contact arrangement _____

Metric
 Imperial

Shell Size	B Max	C Max	C1 Max	F Thread Dia. Class 2B	N Max	T Max	T1 Max	S Max	Oa Min Overlap Accessory
10SL	24,00 0.945	30,00 1.181	100,00 3.937	5/8" x 24 UNEF	42,00 1.654	22,00 0.866	22,70 0.894	5,76 0.227	7,00 0.276
14S	25,00 0.984	30,00 1.181	100,00 3.937	3/4" x 20 UNEF	42,00 1.654	25,00 0.984	27,50 1.083	8,10 0.319	7,00 0.276
16S	27,00 1.063	30,00 1.181	100,00 3.937	7/8" x 20 UNEF	45,00 1.772	28,00 1.102	30,00 1.181	11,30 0.444	7,00 0.276
16	27,00 1.063	30,00 1.181	100,00 3.937	7/8" x 20 UNEF	45,00 1.772	28,00 1.102	30,00 1.181	11,30 0.444	7,00 0.276
18	30,10 1.224	35,00 1.378	100,00 3.937	1" x 20 UNEF	53,00 2.087	31,00 1.220	33,00 1.299	14,45 0.569	7,00 0.276
20	33,00 1.299	35,00 1.378	100,00 3.937	1 1/8" x 18 UNEF	53,00 2.087	35,00 1.378	37,50 1.476	16,00 0.632	7,00 0.276
22	33,10 1.303	35,00 1.378	100,00 3.937	1 1/4" x 18 UNEF	53,00 2.087	38,00 1.496	37,50 1.476	16,00 0.632	7,00 0.276
24	37,90 1.492	40,00 1.575	100,00 3.937	1 3/8" x 18 UNEF	58,00 2.283	41,00 1.614	43,30 1.705	19,23 0.757	7,00 0.276
28	37,10 1.461	40,00 1.575	100,00 3.937	1 5/8" x 18 UNEF	58,00 2.283	48,00 1.890	43,30 1.705	19,23 0.757	7,00 0.276
32	43,10 1.697	45,00 1.772	110,00 4.331	1 7/8" x 16 UN	66,00 2.598	54,00 2.126	51,70 2.035	23,98 0.944	7,00 0.276
36	45,90 1.807	50,00 1.969	110,00 4.331	2 1/16" x 16 UNS	69,00 2.717	61,00 2.402	58,00 2.283	31,93 1.257	7,00 0.276
40	49,00 1.929	54,60 2.150	100,00 3.937	2 5/16" x 16 UN	85,50 3.366	67,00 2.638	65,00 2.559	35,10 1.382	7,00 0.276

Locking 90° Angled Outlet, Sealed Cable Clamp & Grommet

Accessory Type 'FC'

Style: ABBH - ** - ** - FC - F80

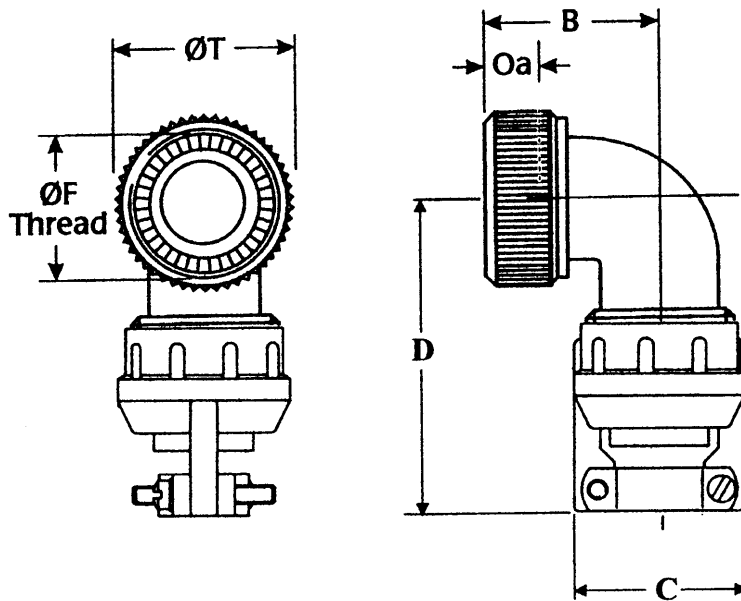

How to order:
ABBH - ** - ** - FC - F80
 Shell size _____
 Contact arrangement _____

Metric
Imperial

Shell Size	B Max	C Max	D Max	F Thread Dia. Class 2B	T Max	Oa Min Overlap Accessory
10SL	24,00 0.945	23,80 0.937	61,00 2.402	5/8" x 24 UNEF	22,00 0.866	7,00 0.276
14S	25,00 0.984	26,97 1.062	61,00 2.402	3/4" x 20 UNEF	25,00 0.984	7,00 0.276
16S	27,00 1.063	30,18 1.188	61,00 2.402	7/8" x 20 UNEF	28,00 1.102	7,00 0.276
16	27,00 1.063	30,18 1.188	61,00 2.402	7/8" x 20 UNEF	28,00 1.102	7,00 0.276
18	30,10 1.224	33,32 1.312	68,00 2.677	1" x 20 UNEF	31,00 1.220	7,00 0.276
20	33,00 1.299	39,67 1.562	68,00 2.677	1 1/8" x 18 UNEF	35,00 1.378	7,00 0.276
22	33,10 1.303	39,67 1.562	68,00 2.677	1 1/4" x 18 UNEF	38,00 1.496	7,00 0.276
24	37,90 1.492	44,45 1.750	76,00 2.992	1 3/8" x 18 UNEF	41,00 1.614	7,00 0.276
28	37,10 1.461	44,45 1.750	76,00 2.992	1 5/8" x 18 UNEF	48,00 1.890	7,00 0.276
32	43,10 1.697	57,15 2.250	87,00 3.425	1 7/8" x 16 UN	54,00 2.126	7,00 0.276
36	45,90 1.807	60,33 2.375	98,00 3.858	2 1/16" x 16 UNS	61,00 2.402	7,00 0.276
40	49,00 1.929	66,68 2.625	103,00 4.055	2 5/16" x 16 UN	67,00 2.638	7,00 0.276



Locking 90° Angled Outlet With Grommet

Accessory Type 'FT'

Style: ABBH - ** - ** - FT - F80

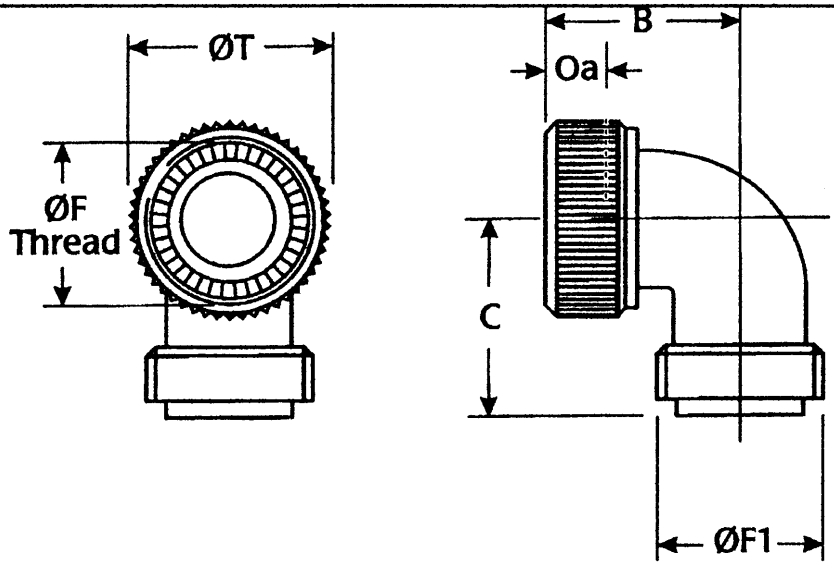

How to order:

ABBH - ** - ** - FT - F80

Shell size _____

Contact arrangement _____

Metric
Imperial

Shell Size	B Max	C Max	F Thread Dia. Class 2B	F1 Thread Dia. Class 2A	T Max	Oa Min Overlap Accessory
10SL	24,00 0.945	30,00 1.181	5/8" x 24 UNEF	5/8" x 24 UNEF	22,00 0.866	7,00 0.276
14S	25,00 0.984	30,00 1.181	3/4" x 20 UNEF	3/4" x 20 UNEF	25,00 0.984	7,00 0.276
16S	27,00 1.063	30,00 1.181	7/8" x 20 UNEF	7/8" x 20 UNEF	28,00 1.102	7,00 0.276
16	27,00 1.063	30,00 1.181	7/8" x 20 UNEF	7/8" x 20 UNEF	28,00 1.102	7,00 0.276
18	30,10 1.224	35,00 1.378	1" x 20 UNEF	1" x 20 UNEF	31,00 1.220	7,00 0.276
20	33,00 1.299	35,00 1.378	1 1/8" x 18 UNEF	1 3/16" x 18 UNEF	35,00 1.378	7,00 0.276
22	33,10 1.303	35,00 1.378	1 1/4" x 18 UNEF	1 3/16" x 18 UNEF	38,00 1.496	7,00 0.276
24	37,90 1.492	40,00 1.575	1 3/8" x 18 UNEF	1 7/16" x 18 NEF	41,00 1.614	7,00 0.276
28	37,10 1.461	40,00 1.575	1 3/8" x 18 UNEF	1 7/16" x 18 NEF	48,00 1.890	7,00 0.276
32	43,10 1.697	45,00 1.772	1 7/8" x 16 UN	1 3/4" x 18 UNS	54,00 2.126	7,00 0.276
36	45,90 1.807	50,00 1.969	2 1/16" x 16 UNS	2" x 18 UNS	61,00 2.402	7,00 0.276
40	49,00 1.929	54,60 2.150	2 5/16" x 16 UN	2 1/4" x 16 UN	67,00 2.638	7,00 0.276

Locking 90° Outlet RFI Shielded With Grommet

Accessory Type 'FM'

Style: ABBH - ** - ** - FM - F80

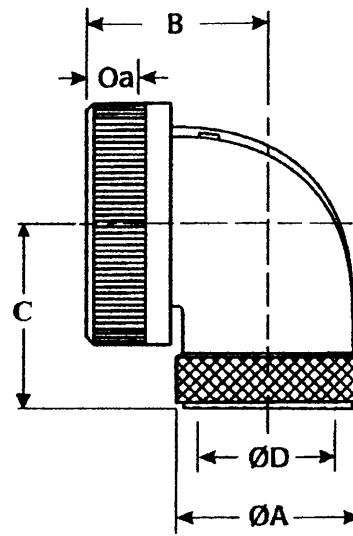
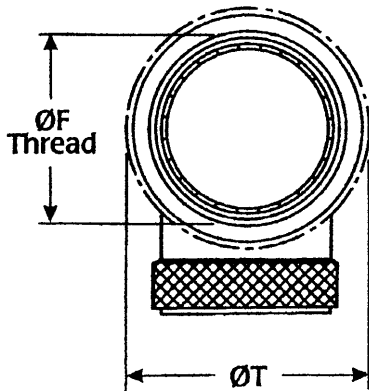

How to order:

ABBH - ** - ** - FM - F80

Shell size

Contact arrangement

Metric
Imperial

Shell Size	A Max	B Max	C Max	D Max	F Thread Dia. Class 2B	T Max	Oa Min Overlap Accessory
10SL	15,90 0.626	24,00 0.945	30,00 1.181	7,77 0.306	5/8" x 24 UNEF	22,00 0.866	7,00 0.276
14S	19,10 0.764	25,00 0.984	30,00 1.181	10,36 0.408	3/4" x 20 UNEF	25,00 0.984	7,00 0.276
16S	22,30 0.878	27,00 1.063	30,00 1.181	13,01 0.512	7/8" x 20 UNEF	28,00 1.102	7,00 0.276
16	22,30 0.878	27,00 1.063	30,00 1.181	13,01 0.512	7/8" x 20 UNEF	28,00 1.102	7,00 0.276
18	25,50 1.004	30,10 1.224	35,00 1.378	15,14 0.596	1" x 20 UNEF	31,00 1.220	7,00 0.276
20	30,20 1.189	33,00 1.299	35,00 1.378	18,10 0.713	1 1/8" x 18 UNEF	35,00 1.378	7,00 0.276
22	30,20 1.189	33,10 1.303	35,00 1.378	21,62 0.851	1 1/4" x 18 UNEF	38,00 1.496	7,00 0.276
24	36,60 1.441	37,90 1.492	40,00 1.575	25,10 0.988	1 3/8" x 18 UNEF	41,00 1.614	7,00 0.276
28	36,60 1.441	37,10 1.461	40,00 1.575	30,38 1.196	1 5/8" x 18 UNEF	48,00 1.890	7,00 0.276
32	44,50 1.752	43,10 1.697	45,00 1.772	36,48 1.436	1 7/8" x 16 UN	54,00 2.126	7,00 0.276
36	50,90 2.004	45,90 1.807	50,00 1.969	40,67 1.601	2 1/16" x 16 UNS	61,00 2.402	7,00 0.276
40	57,20 2.252	49,00 1.929	54,60 2.150	48,50 1.909	2 5/16" x 16 UN	67,00 2.638	7,00 0.276

Locking Heatshrink Adaptor With Grommet

Accessory Type 'G'

Style: ABBH - ** - ** - HSA - F80

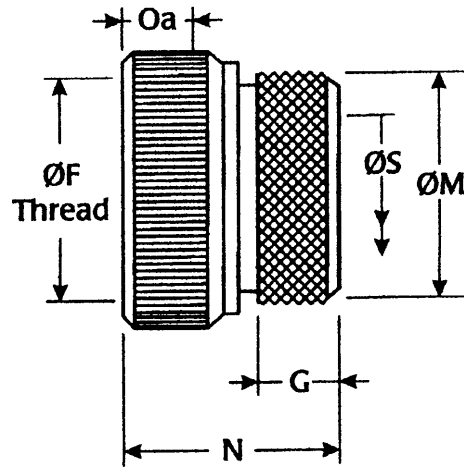
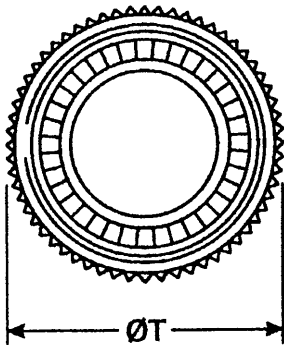

Metric
Imperial

How to order:
ABBH - ** - ** - HSA - F80
 Shell size _____
 Contact arrangement _____

Shell Size	F Thread Dia. Class 2B	G Max	M Max	N Max	S Min	T Max	Oa Min Overlap Accessory
10SL	5/8" x 24 UNEF	8,20 0.323	15,70 0.618	28.46 1.120	7,70 0.303	22,00 0.87	7,00 0.276
14S	3/4" x 20 UNEF	8,20 0.323	19,30 0.760	28.46 1.120	10.60 0.417	25,00 0.99	7,00 0.276
16S	7/8" x 20 UNEF	8,20 0.323	24,10 0.949	28.46 1.120	13,50 0.532	28,00 1.11	7,00 0.276
16	7/8" x 20 UNEF	8,00 0.315	24,10 0.949	32.26 1.270	13,50 0.532	28,00 1.11	7,00 0.276
18	1" x 20 UNEF	8,00 0.315	24,10 0.949	32.26 1.270	14,60 0.575	31,00 1.22	7,00 0.276
20	1 1/8" x 18 UNEF	9,20 0.362	29,80 1.173	35.80 1.409	18,70 0.736	35,00 1.38	7,00 0.276
22	1 1/4" x 18 UNEF	9,20 0.362	29,80 1.173	35.80 1.409	20,80 0.819	38,00 1.50	7,00 0.276
24	1 3/8" x 18 UNEF	9,20 0.362	38,00 1.496	35.80 1.409	24,60 0.969	41,00 1.62	7,00 0.276
28	1 5/8" x 18 UNEF	9,20 0.362	38,00 1.496	35.76 1.408	27,00 1.063	48,00 1.89	7,00 0.276
32	1 7/8" x 16 UN	11,70 0.461	48,00 1.890	38.26 1.506	33,30 1.311	54,00 2.13	7,00 0.276
36	2 1/16" x 16 UNS	11,70 0.461	48,00 1.890	39.26 1.546	38,50 1.516	61,00 2.40	7,00 0.276
40	2 5/16" x 16 UN	12,10 0.476	57,95 2.281	38.30 1.508	48,10 1.894	67,00 2.638	7,00 0.276



Locking RFI Shielded Adaptor With Grommet

Accessory Type 'GM'

Style: ABBH - ** - ** - LHSA - F80

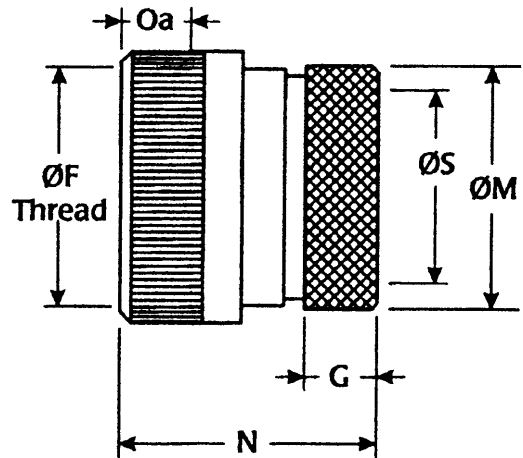
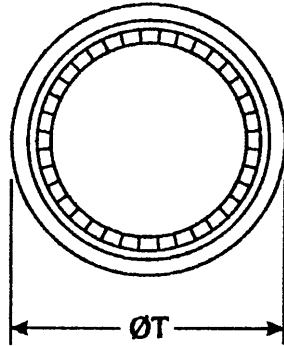

Metric
Imperial

How to order:

ABBH - ** - ** - LHSA - F80

Shell size

Contact arrangement

Shell Size	F Thread Dia. Class 2B	G Max	M Max	N Max	S Min	T Max	Oa Min Overlap Accessory
10SL	5/8" x 24 UNEF	12,40 0.488	15,70 0.618	32,26 1.270	8,60 0.339	22,00 0.87	7,00 0.276
14S	3/4" x 20 UNEF	12,40 0.488	19,30 0.760	32,26 1.270	11,10 0.437	25,00 0.984	7,00 0.276
16S	7/8" x 20 UNEF	12,40 0.488	24,10 0.949	32,26 1.270	14,30 0.563	28,00 1.102	7,00 0.276
16	7/8" x 20 UNEF	12,40 0.488	24,10 0.949	36,06 1.420	14,30 0.563	28,00 1.102	7,00 0.276
18	1" x 20 UNEF	12,40 0.488	24,10 0.949	36,06 1.420	16,70 0.657	31,00 1.22	7,00 0.276
20	1 1/8" x 18 UNEF	12,40 0.488	29,80 1.173	38,60 1.520	19,80 0.780	35,00 1.38	7,00 0.276
22	1 1/4" x 18 UNEF	12,40 0.488	29,80 1.173	38,60 1.520	21,34 0.840	38,00 1.50	7,00 0.276
24	1 3/8" x 18 UNEF	12,40 0.488	38,00 1.496	38,60 1.520	25,40 1.000	41,00 1.62	7,00 0.276
28	1 5/8" x 18 UNEF	12,40 0.488	38,00 1.496	38,56 1.518	30,13 1.186	48,00 1.89	7,00 0.276
32	1 7/8" x 16 UN	12,10 0.476	48,00 1.890	38,26 1.506	36,73 1.446	54,00 2.13	7,00 0.276
36	2 1/16" x 16 UNS	12,10 0.476	48,00 1.890	39,26 1.546	41,00 1.614	61,00 2.40	7,00 0.276
40	2 5/16" x 16 UN	12,10 0.476	57,95 2.281	38,30 1.508	48,10 1.894	67,00 2.638	7,00 0.276

Non-Locking Heatshrink Adaptor With Grommet & Follower Accessory Type 'GS'

Style: ABBH - ** - ** - HSAS - F80

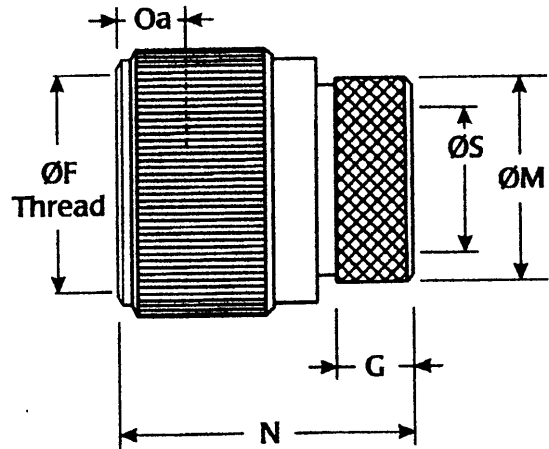
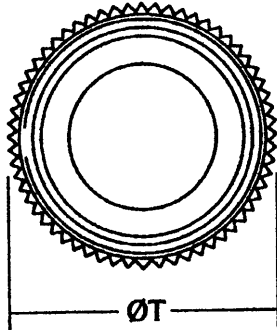

How to order:
ABBH - ** - ** - HSAS - F80
 Shell size ————
 Contact arrangement ————

Metric
Imperial

Shell Size	F Thread Dia. Class 2B	M Max	G Max	N Max	S Min	T Max	Oa Min Overlap Accessory
*10SL	-	-	-	-	-	-	-
*14S	-	-	-	-	-	-	-
*16S	-	-	-	-	-	-	-
*16	-	-	-	-	-	-	-
18	1" x 20 UNEF	24,10 0.949	11,90 0.469	45,30 1.783	14,70 0.579	28,60 1.126	7,34 0.289
20	1 1/8" x 18 UNEF	29,80 1.173	11,90 0.469	51,10 2.012	18,70 0.736	31,85 1.254	7,34 0.289
22	1 1/4" x 18 UNEF	29,80 1.173	11,90 0.469	51,10 2.012	20,90 0.823	35,03 1.379	7,14 0.281
24	1 3/8" x 18 UNEF	38,00 1.496	11,90 0.469	51,10 2.012	24,70 0.972	39,10 1.539	7,14 0.281
28	1 5/8" x 18 UNEF	38,00 1.496	11,90 0.469	51,10 2.012	27,10 1.067	45,60 1.795	6,34 0.250
32	1 7/8" x 16 UN	48,00 1.890	11,90 0.469	51,10 2.012	33,40 1.315	50,80 2.000	7,40 0.291
36	2 1/16" x 16 UNS	48,00 1.890	11,90 0.469	51,10 2.012	38,60 1.520	57,45 2.262	7,40 0.291
40	2 5/16" x 16 UN	57,95 2.281	11,90 0.469	51,10 2.012	48,10 1.894	63,10 2.484	7,40 0.291

*Please consult factory for availability.

Locking Armoured Conduit Adaptor With Grommet

Accessory Type 'H'

Style: ABBH - ** - ** - ACA - F80

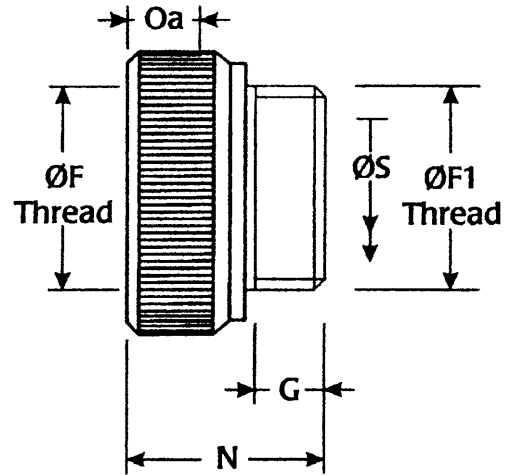
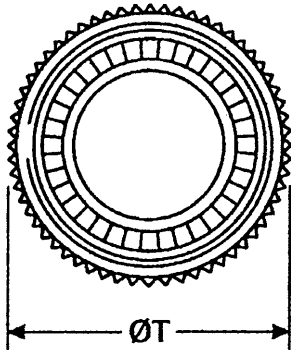

How to order:

ABBH - ** - ** - ACA - F80

Shell size

Contact arrangement

Metric
Imperial

Shell Size	F Thread Dia. Class 2B	F1 Thread Dia. Class 2A	G Max	N Max	S Min	T Max	Oa Min Overlap Accessory
10SL	5/8" x 24 UNEF	5/8" x 24 UNEF	9,50 0.374	27,90 1.098	8,20 0.323	22,00 0.87	7,00 0.276
14S	3/4" x 20 UNEF	3/4" x 20 UNEF	9,50 0.374	27,90 1.098	11,10 0.437	25,00 0.99	7,00 0.276
16S	7/8" x 20 UNEF	7/8" x 20 UNEF	9,50 0.374	27,90 1.098	14,30 0.563	28,00 1.11	7,00 0.276
16	7/8" x 20 UNEF	7/8" x 20 UNEF	9,50 0.374	27,90 1.098	14,30 0.563	28,00 1.11	7,00 0.276
18	1" x 20 UNEF	1" x 20 UNEF	9,50 0.374	29,90 1.177	16,70 0.657	31,00 1.22	7,00 0.276
20	1 1/8" x 18 UNEF	1 3/16" x 18 NEF	9,50 0.374	29,90 1.177	19,80 0.780	35,00 1.38	7,00 0.276
22	1 1/4" x 18 UNEF	1 3/16" x 18 NEF	9,50 0.374	29,90 1.177	19,80 0.780	38,00 1.50	7,00 0.276
24	1 3/8" x 18 UNEF	1 7/16" x 18 NEF	9,50 0.374	29,90 1.177	25,40 1.000	41,00 1.62	7,00 0.276
28	1 5/8" x 18 UNEF	1 7/16" x 18 NEF	9,50 0.374	30,00 1.181	27,00 1.063	48,00 1.89	7,00 0.276
32	1 7/8" x 16 UN	1 3/4" x 18 NS	11,00 0.433	28,90 1.138	32,50 1.280	54,00 2.13	7,00 0.276
36	2 1/16" x 16 UNS	2" x 18 NS	11,80 0.464	28,90 1.138	35,70 1.406	61,00 2.40	7,00 0.276
40	2 5/16" x 16 UN	2 1/4" x 16 UN	11,80 0.464	28,90 1.138	45,00 1.772	67,00 2.638	7,00 0.276

Locking Cable Clamp With Grommet

Accessory Type 'HC'

Style: ABBH - ** - ** - HC - F80

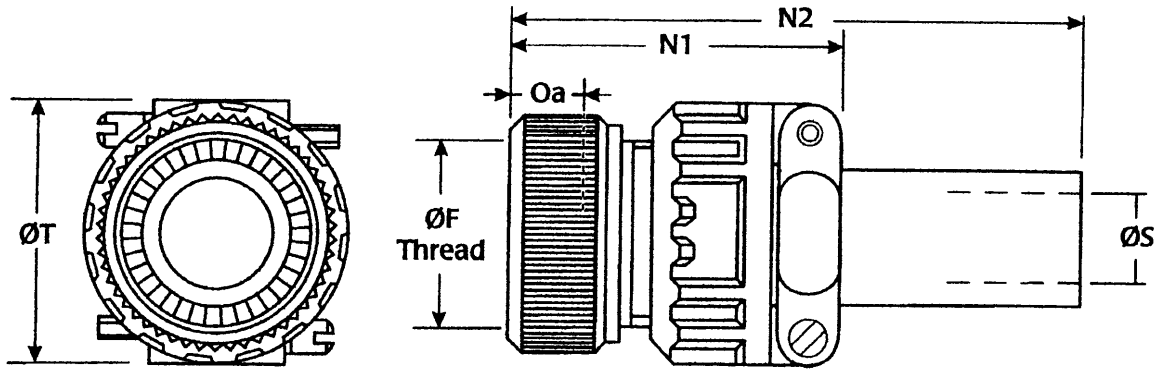

How to order:

ABBH - ** - ** - HC - F80

Shell size

Contact arrangement

Metric
Imperial

Note.
Clamp & bush are available separately. See pages 74 & 76 respectively.

Shell Size	F Thread Dia. Class 2B	N1 Max	N2 Max	S	T Max	Oa Min Overlap Accessory
10SL	5/8" x 24 UNEF	40,10 1.58	100,10 3.94	5.59 0.220	22,70 0.90	7,00 0.276
14S	3/4" x 20 UNEF	41,70 1.65	96,70 3.81	7.92 0.312	27,50 1.09	7,00 0.276
16S	7/8" x 20 UNEF	43,50 1.72	98,50 3.88	11.10 0.437	30,00 1.19	7,00 0.276
16	7/8" x 20 UNEF	43,50 1.72	93,50 3.68	11.10 0.437	30,00 1.19	7,00 0.276
18	1" x 20 UNEF	50,00 1.97	95,00 3.74	14.27 0.562	33,00 1.30	7,00 0.276
20	1 1/8" x 18 UNEF	45,50 1.80	90,50 3.57	15.88 0.625	37,50 1.48	7,00 0.276
22	1 1/4" x 18 UNEF	45,50 1.80	90,50 3.57	15.88 0.625	37,50 1.48	7,00 0.276
24	1 3/8" x 18 UNEF	47,50 1.87	77,50 3.05	19.05 0.750	43,30 1.71	7,00 0.276
28	1 5/8" x 18 UNEF	47,60 1.88	77,60 3.06	19.05 0.750	43,30 1.71	7,00 0.276
32	1 7/8" x 16 UN	46,50 1.83	76,50 3.02	23.80 0.937	51,70 2.04	7,00 0.276
36	2 1/16" x 16 UNS	46,40 1.826	76,40 3.01	31.75 1.250	58,00 2.29	7,00 0.276
40	2 5/16" x 16 UN	59,80 2.35	73,80 2.90	34.92 1.375	65,00 2.56	7,00 0.276



Locking Sealed Cable Clamp With Grommet

Accessory Type 'HD'

Style: ABBH - ** - ** - HD - F80

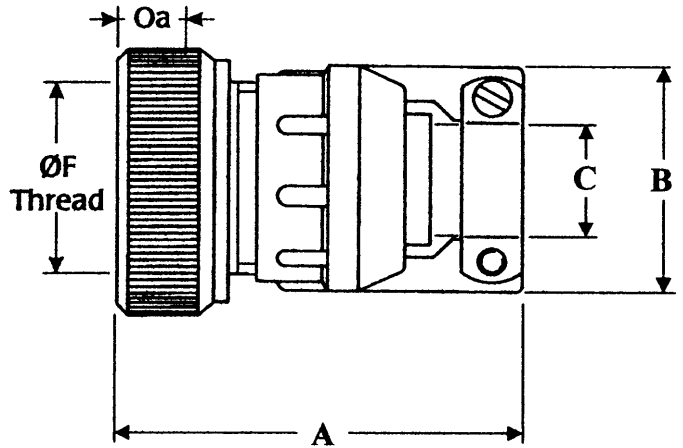
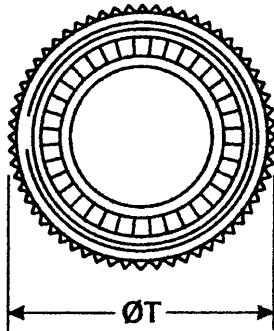

Metric
Imperial

How to order:

ABBH - ** - ** - HD - F80

Shell size

Contact arrangement

Shell Size	A Max	B	C		F Thread Dia. Class 2B	T Max	Oa Min Overlap Accessory
			Max	Min			
10SL	58,87 2.318	23,80 0.937	7,93 0.312	2,38 0.094	5/8" x 24 UNEF	22,00 0.866	7,00 0.276
14S	58,87 2.318	26,97 1.062	11,12 0.438	6,35 0.250	3/4" x 20 UNEF	25,00 0.984	7,00 0.276
16S	58,87 2.318	30,18 1.188	13,48 0.531	7,92 0.312	7/8" x 20 UNEF	28,00 0.984	7,00 0.276
16	58,87 2.318	30,18 1.188	13,48 0.531	7,92 0.312	7/8" x 20 UNEF	28,00 0.984	7,00 0.276
18	62,44 2.458	33,32 1.312	15,87 0.625	9,53 0.375	1" x 20 UNEF	31,00 1.220	7,00 0.276
20	62,44 2.458	39,21 1.562	19,00 0.748	12,70 0.500	1 1/8" x 18 UNEF	35,00 1.378	7,00 0.276
22	62,44 2.458	39,21 1.562	19,00 0.748	12,70 0.500	1 1/4" x 18 UNEF	38,00 1.496	7,00 0.276
24	65,61 2.583	44,45 1.750	23,80 0.937	15,09 0.594	1 3/8" x 18 UNEF	41,00 1.614	7,00 0.276
28	65,71 2.587	44,45 1.750	23,80 0.937	15,09 0.594	1 5/8" x 18 UNEF	48,00 1.890	7,00 0.276
32	70,96 2.794	57,15 2.250	31,75 1.250	23,83 0.938	1 7/8" x 16 UN	54,00 2.126	7,00 0.276
36	77,31 3.044	60,33 2.375	35,00 1.378	24,61 0.969	2 1/16" x 16 UNS	61,00 2.402	7,00 0.276
40	77,31 3.044	66,68 2.625	41,25 1.624	30,18 1.188	2 5/16" x 16 UN	67,00 2.638	7,00 0.276

Non-Locking Cable Clamp With Grommet & Follower

Accessory Type 'JE'

Style: ABBH - ** - ** - JE - F80

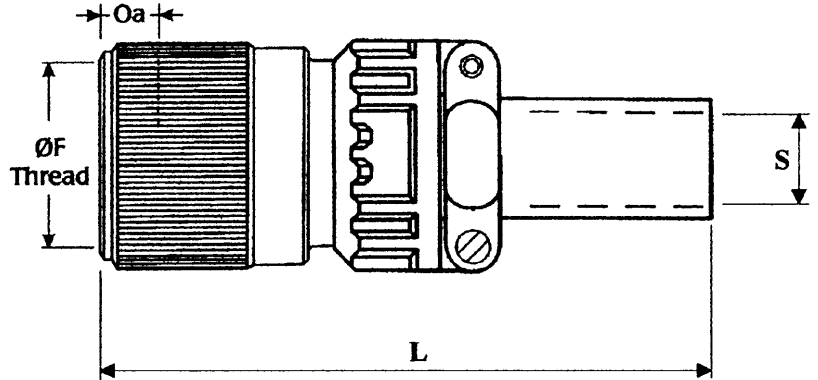
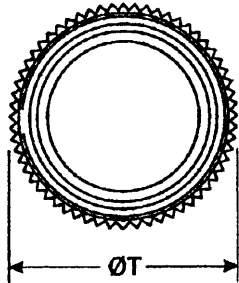

Metric
Imperial

How to order:
ABBH - ** - ** - JE - F80
 Shell size _____
 Contact arrangement _____

Shell Size	F Thread dia. Class 2B	L Max	S	T Max	Oa Min Overlap Accessory
10SL	5/8" x 24 UNEF	99,13 3.903	5.59 0.220	19,10 0.752	7,00 0.276
14S	3/4" x 20 UNEF	95,96 3.778	7.92 0.312	22,10 0.870	7,00 0.276
16S	7/8" x 20 UNEF	92,78 6.653	11.10 0.437	25,50 1.004	7,00 0.276
16	7/8" x 20 UNEF	94,28 3.712	11.10 0.437	25,50 1.004	7,00 0.276
18	1" x 20 UNEF	97,51 3.839	14.27 0.562	28,60 1.126	7,34 0.289
20	1 1/8" x 18 UNEF	94,33 3.714	15.88 0.625	31,85 1.254	7,34 0.289
22	1 1/4" x 18 UNEF	94,33 3.714	15.88 0.625	35,03 1.379	7,34 0.289
24	1 3/8" x 18 UNEF	94,01 3.701	19.05 0.750	39,10 1.539	7,14 0.281
28	1 5/8" x 18 UNEF	94,01 3.701	19.05 0.750	45,60 1.795	6,34 0.250
32	1 7/8" x 16 UN	90,83 3.576	23.80 0.937	50,80 2.000	7,40 0.291
36	2 1/16" x 16 UNS	87,67 3.452	31.75 1.250	57,45 2.262	7,40 0.291
40	2 5/16" x 16 UN	84,43 3.324	34.92 1.375	63,10 2.484	6,34 0.250

Locking Screened Cable Adaptor With Grommet

Accessory Type 'M'

Style: ABBH - ** - ** - SCA - F80

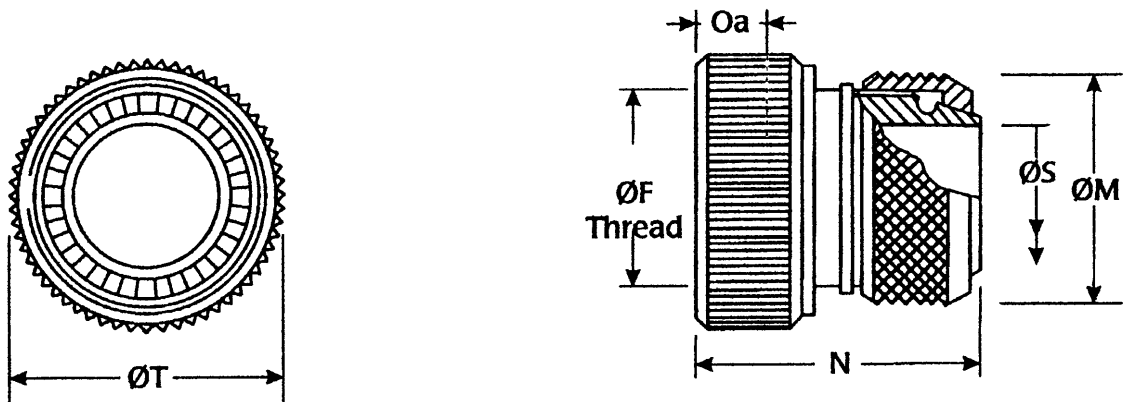

How to order:

ABBH - ** - ** - SCA - F80

Shell size

Contact arrangement

Metric
Imperial

Shell Size	F Thread Dia. Class 2B	M Max	N Max	S Min	T Max	Oa Min Overlap Accessory
10SL	5/8" x 24 UNEF	19,00 0.748	31,30 0.812	8,60 0.339	22,00 0.87	7,00 0.276
14S	3/4" x 20 UNEF	22,50 0.886	33,90 1.335	10,60 0.417	25,00 0.99	7,00 0.276
16S	7/8" x 20 UNEF	25,50 1.004	33,90 1.335	13,50 0.532	28,00 1.11	7,00 0.276
16	7/8" x 20 UNEF	25,50 1.004	33,90 1.335	13,50 0.532	28,00 1.11	7,00 0.276
18	1" x 20 UNEF	25,50 1.004	36,90 1.453	14,60 0.575	31,00 1.22	7,00 0.276
20	1 1/8" x 18 UNEF	32,50 1.280	36,90 1.453	18,50 0.728	35,00 1.38	7,00 0.276
22	1 1/4" x 18 UNEF	34,50 1.358	36,90 1.453	20,80 0.819	38,00 1.50	7,00 0.276
24	1 3/8" x 18 UNEF	38,50 1.516	36,90 1.453	24,60 0.969	41,00 1.62	7,00 0.276
28	1 5/8" x 18 UNEF	41,50 1.634	35,90 1.413	27,00 1.063	48,00 1.89	7,00 0.276
32	1 7/8" x 16 UN	48,50 1.910	35,90 1.413	33,30 1.311	54,00 2.13	7,00 0.276
36	2 1/16" x 16 UNS	55,50 2.185	35,90 1.413	38,50 1.516	61,00 2.40	7,00 0.276
40	2 5/16" x 16 UN	62,50 2.461	35,90 1.413	45,00 1.772	67,00 2.638	7,00 0.276

Non-Locking Conduit Adaptor With Grommet & Follower

Accessory Type 'R'

Style: ABBH - ** - ** - CCA - F80

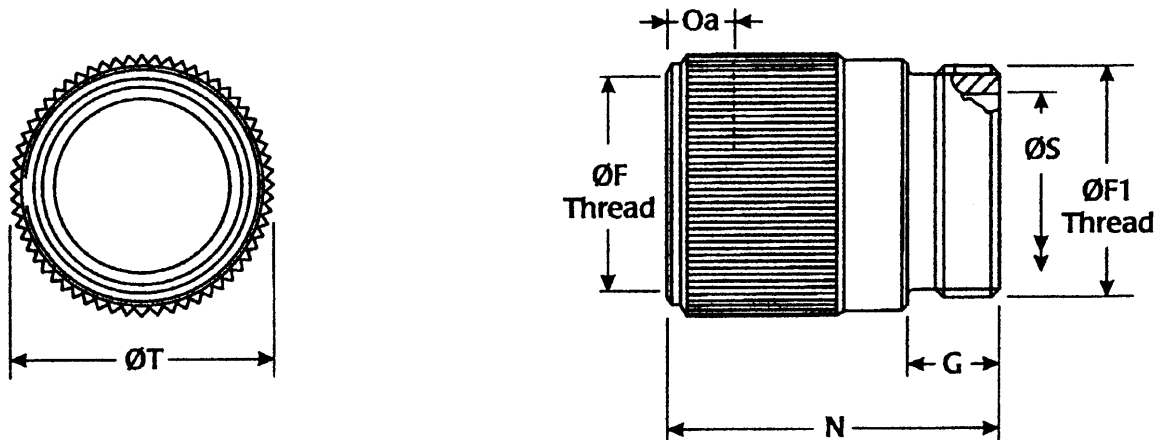

How to order:
ABBH - ** - ** - CCA - F80
 Shell size _____
 Contact arrangement _____

Metric
Imperial

Shell Size	F Thread Dia. Class 2B	F1 Thread Dia. Class 2A	G Max	N Max	S Min	T Max	Oa Min Overlap Accessory
10SL	5/8" x 24 UNEF	5/8" x 24 UNEF	10,10 0.398	29,10 1.146	8,80 0.346	19,10 0.752	7,00 0.276
14S	3/4" x 20 UNEF	3/4" x 20 UNEF	10,10 0.398	29,10 1.146	11,30 0.445	22,10 0.870	7,00 0.276
16S	7/8" x 20 UNEF	7/8" x 20 UNEF	10,10 0.398	29,10 1.146	18,54 0.730	25,50 1.004	7,00 0.276
16	7/8" x 20 UNEF	7/8" x 20 UNEF	10,10 0.398	30,60 1.205	18,54 0.730	25,50 1.004	7,00 0.276
18	1" x 20 UNEF	1" x 20 UNEF	10,10 0.398	37,00 1.457	16,70 0.657	28,60 1.126	7,34 0.289
20	1 1/8" x 18 UNEF	1 3/16" x 18 UNEF	10,10 0.398	37,00 1.457	19,80 0.780	31,85 1.254	7,34 0.289
22	1 1/4" x 18 UNEF	1 3/16" x 18 UNEF	10,10 0.398	37,00 1.457	19,80 0.780	35,03 1.379	7,34 0.289
24	1 3/8" x 18 UNEF	1 7/16" x 18 UNEF	11,10 0.437	39,85 1.569	25,40 1.000	39,10 1.539	7,14 0.281
28	1 5/8" x 18 UNEF	1 7/16" x 18 UNEF	11,10 0.437	39,85 1.569	30,13 1.186	45,60 1.795	6,34 0.250
32	1 7/8" x 16 UN	1 3/4" x 18 UNS	11,10 0.437	39,85 1.569	32,50 1.280	50,80 2.000	7,40 0.291
36	2 1/16" x 16 UNS	2" x 18 UNS	11,10 0.437	39,85 1.569	35,70 1.406	57,45 2.262	7,40 0.291
40	2 5/16" x 16 UN	2 1/4" x 16 UN	11,10 0.437	39,85 1.569	45,00 1.772	63,10 2.484	6,34 0.250



Non-Locking Sealed Cable Clamp With Grommet & Followe Accessory Type 'RC'

Style: ABBH - ** - ** - RC - F80

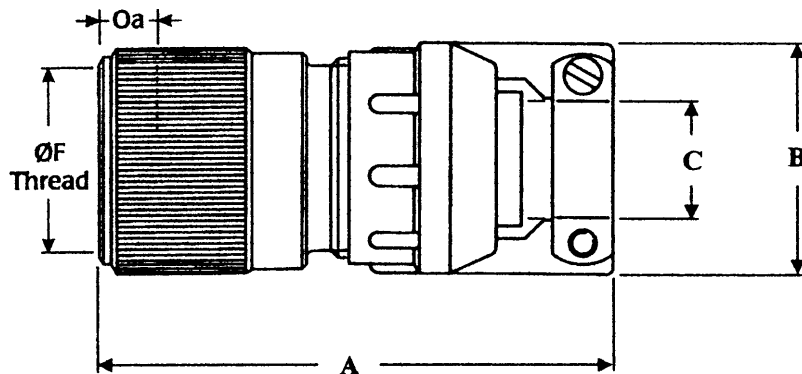
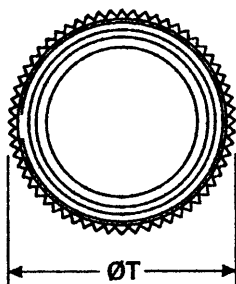

Metric
Imperial

How to order:
ABBH - ** - ** - RC - F80
 Shell size _____
 Contact arrangement _____

Shell Size	A Max	B	C		F Thread Dia. Class 2B	T Max	Oa Min Overlap Accessory
			Max	Min			
10SL	59,10 2.327	23,80 0.937	7,93 0.312	2,38 0.094	5/8" x 24 UNEF	19,10 0.752	7,00 0.276
14S	59,10 2.327	26,97 1.062	11,12 0.438	6,35 0.250	3/4" x 20 UNEF	22,10 0.870	7,00 0.276
16S	59,10 2.327	30,18 1.188	13,48 0.531	7,92 0.312	7/8" x 20 UNEF	25,50 1.004	7,00 0.276
16	60,60 2.386	30,18 1.188	13,48 0.531	7,92 0.312	7/8" x 20 UNEF	25,50 1.004	7,00 0.276
18	70,00 2.756	33,32 1.312	15,87 0.625	9,53 0.375	1" x 20 UNEF	28,60 1.126	7,34 0.289
20	70,00 2.756	39,21 1.562	19,00 0.748	12,70 0.500	1 1/8" x 18 UNEF	31,85 1.254	7,34 0.289
22	70,00 2.756	39,21 1.562	19,00 0.748	12,70 0.500	1 1/4" x 18 UNEF	35,03 1.379	7,34 0.289
24	75,85 2.986	44,45 1.750	23,80 0.937	15,09 0.594	1 3/8" x 18 UNEF	39,10 1.539	7,14 0.281
28	75,85 2.986	44,45 1.750	23,80 0.937	15,09 0.594	1 5/8" x 18 UNEF	45,60 1.795	6,34 0.250
32	81,85 3.222	57,15 2.250	31,75 1.250	23,83 0.938	1 7/8" x 16 UN	50,80 2.000	7,40 0.291
36	88,85 3.498	60,33 2.375	35,00 1.378	24,61 0.969	2 1/16" x 16 UNS	57,45 2.262	7,40 0.291
40	88,85 3.498	66,68 2.625	41,25 1.624	30,18 1.188	2 5/16" x 16 UN	63,10 2.484	6,34 0.250



Long Backshell With Grommet, Cable Clamp & Bushing

Accessory Type 'XLA'

Style: ABBH - ** - ** - XLA - F80

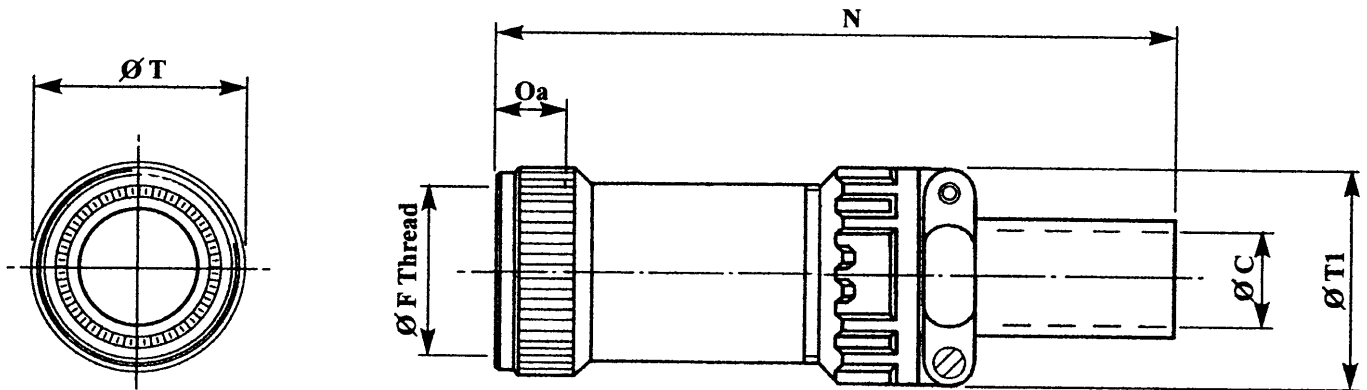

How to order:

ABBH - ** - ** - XLA - F80

Shell size

Contact arrangement

Metric
Imperial

Shell Size	C	F Thread Dia. Class 2B	N	T Max	T1 Max	Oa Min Overlap Accessory
10SL	5,59 0.220	5/8" x 24 UNEF	118,35 4.659	22,00 0.866	22,70 0.894	7,00 0.276
14S	7,92 0.312	3/4" x 20 UNEF	115,18 4.535	25,00 0.984	27,50 1.083	7,00 0.276
16S	11,10 0.437	7/8" x 20 UNEF	112,00 4.409	28,00 1.102	30,00 1.181	7,00 0.276
16	11,10 0.437	7/8" x 20 UNEF	122,30 4.815	28,00 1.102	30,00 1.181	7,00 0.276
18	14,27 0.562	1" x 20 UNEF	119,13 4.690	31,00 1.220	33,00 1.299	7,00 0.276
20	15,88 0.625	1 1/8" x 18 UNEF	115,95 4.565	35,00 1.378	37,50 1.476	7,00 0.276
22	15,88 0.625	1 1/4" x 18 UNEF	115,95 4.565	38,00 1.496	37,50 1.476	7,00 0.276
24	19,05 0.750	1 3/8" x 18 UNEF	112,78 4.440	41,00 1.614	43,30 1.704	7,00 0.276
28	19,05 0.750	1 5/8" x 18 UNEF	119,78 4.716	48,00 1.889	43,30 1.704	7,00 0.276
32	23,80 0.937	1 7/8" x 16 UN	116,60 4.591	54,00 2.126	51,70 2.035	7,00 0.276
36	31,75 1.250	2 1/16" x 16 UNS	113,43 4.466	61,00 2.402	58,00 2.283	7,00 0.276
40	34,92 1.375	2 5/16" x 16 UN	110,20 4.338	67,00 2.638	65,00 2.559	7,00 0.276



Long Backshell With Grommet & Sealed Cable Clamp

Accessory Type 'XLC'

Style: ABBH - ** - ** - XLC - F80

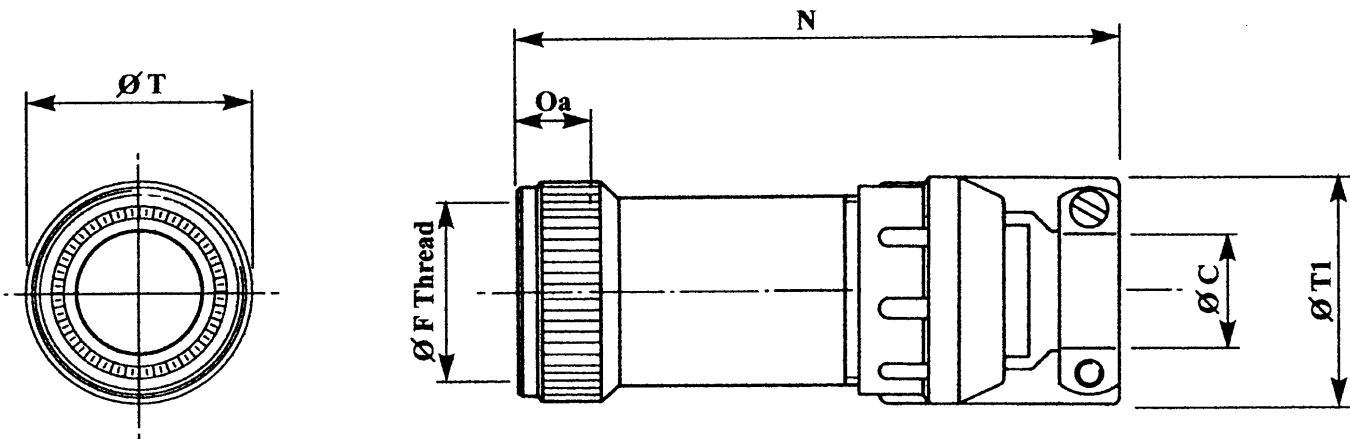

Metric
Imperial

How to order:
ABBH - ** - ** - XLC - F80
 Shell size _____
 Contact arrangement _____

Shell Size	C		F Thread Dia. Class 2B	N	T Max	T1 Max	Oa Min Overlap Accessory
	Max	Min					
10SL	7,93 0.312	2,38 0.094	5/8" x 24 UNEF	79,47 3.129	22,00 0.866	23,80 0.937	7,00 0.276
14S	11,12 0.438	6,35 0.250	3/4" x 20 UNEF	79,47 3.129	25,00 0.984	26,97 1.062	7,00 0.276
16S	13,48 0.531	7,92 0.312	7/8" x 20 UNEF	79,47 3.129	28,00 1.102	30,18 1.188	7,00 0.276
16	13,48 0.531	7,92 0.312	7/8" x 20 UNEF	91,33 3.596	28,00 1.102	30,18 1.188	7,00 0.276
18	15,87 0.625	9,53 0.375	1" x 20 UNEF	91,33 3.596	31,00 1.220	33,32 1.312	7,00 0.276
20	19,00 0.748	12,70 0.500	1 1/8" x 18 UNEF	91,33 3.596	35,00 1.378	39,67 1.562	7,00 0.276
22	19,00 0.748	12,70 0.500	1 1/4" x 18 UNEF	91,33 3.596	38,00 1.496	39,67 1.562	7,00 0.276
24	23,80 0.937	15,09 0.594	1 3/8" x 18 UNEF	94,51 3.721	41,00 1.614	44,45 1.750	7,00 0.276
28	23,80 0.937	15,09 0.594	1 5/8" x 18 UNEF	101,51 3.996	48,00 1.889	44,45 1.750	7,00 0.276
32	31,75 1.250	23,83 0.938	1 7/8" x 16 UN	107,86 4.246	54,00 2.126	57,15 2.250	7,00 0.276
36	35,00 1.378	24,61 0.969	2 1/16" x 16 UNS	114,21 4.496	61,00 2.402	60,33 2.375	7,00 0.276
40	41,25 1.624	30,18 1.188	2 5/16" x 16 UN	114,21 4.496	67,00 2.638	66,68 2.625	7,00 0.276

Long Back With Grommet

Accessory Type 'SHE'

Style: ABBH - ** - ** - SHE - F80

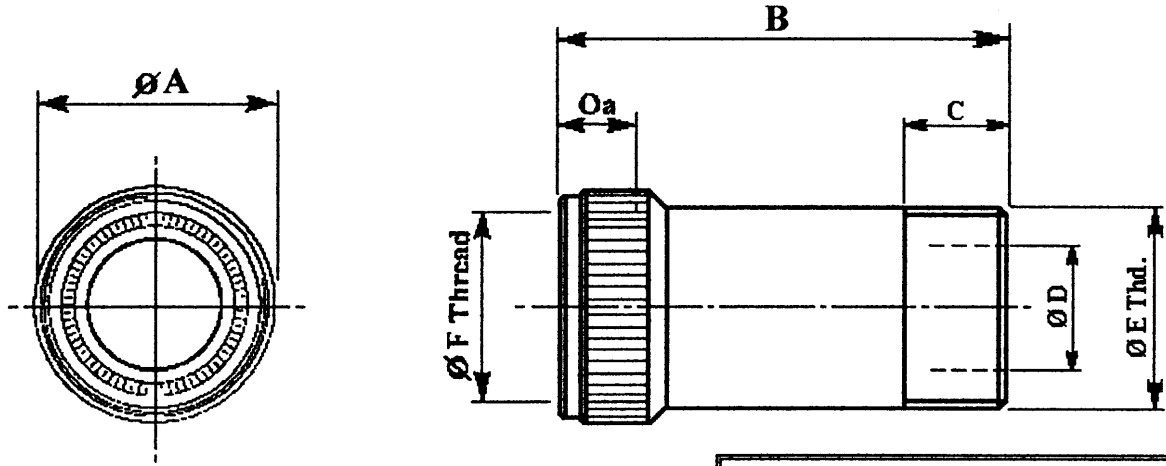

How to order:
ABBH - ** - ** - SHE - F80
 Shell size _____
 Contact arrangement _____

Metric
 Imperial

Shell Size	Ø A (Max.)	B	C ±0.10	Ø D +0 / -0.10	Ø E Thd.	Ø F Thd.	Øa (Min)
10SL	22,0 0.866	48,5 1.909	15,0 0.591	8,5 0.335	5/8" x 24 UNEF	5/8" x 24 UNEF	7,0 0.276
14S	25,0 0.984	48,5 1.909	15,0 0.591	11,7 0.461	3/4" x 20 UNEF	3/4" x 20 UNEF	7,0 0.276
16S	28,0 1.102	48,5 1.909	15,0 0.591	13,9 0.547	7/8" x 20 UNEF	7/8" x 20 UNEF	7,0 0.276
16	28,0 1.103	58,8 2.303	15,0 0.591	13,9 0.547	7/8" x 20 UNEF	7/8" x 20 UNEF	7,0 0.276
18	31,0 1.220	58,8 2.303	15,0 0.591	16,9 0.666	1" x 20 UNEF	1" x 20 UNEF	7,0 0.276
20	35,0 1.378	58,8 2.303	15,0 0.591	20,9 0.823	1 3/16" x 18 UNEF	1 1/8" x 18 UNEF	7,0 0.276
22	38,0 1.496	58,8 2.303	15,0 0.591	20,9 0.823	1 3/16" x 18 UNEF	1 1/4" x 18 UNEF	7,0 0.276
24	41,0 1.614	58,8 2.303	15,0 0.591	25,9 1.020	1 7/16" x 18 UNEF	1 3/8" x 18 UNEF	7,0 0.276
28	48,0 1.890	65,8 2.303	15,0 0.591	25,9 1.020	1 7/16" x 18 UNEF	1 5/8" x 18 UNEF	7,0 0.276
32	54,0 2.126	65,8 2.303	15,0 0.591	32,0 1.260	1 3/4" x 18 UNS	1 7/8" x 16 UN	7,0 0.276
36	61,0 2.402	65,8 2.303	15,0 0.591	36,9 1.453	2" x 18 UNS	2 1/16" x 16 UNS	7,0 0.276
40	67,0 2.638	65,8 2.303	15,0 0.591	44,9 1.768	2 1/4" x 16 UN	2 5/16" x 16 UN	7,0 0.276

PG Threaded Adaptors (DIN 40430)

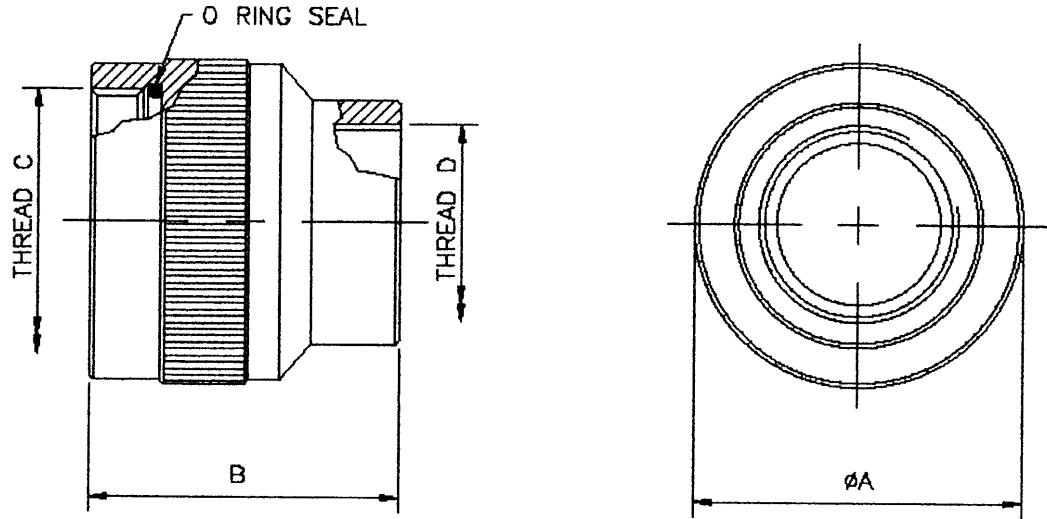

Metric
Imperial

Note. PG threaded adaptors are used in conjunction with straight and 90° backshell styles: ACA, CCA, XL & FT.
For other sizes, please contact the Sales Office.

Part Number	Shell Size	Ø A	B	Thread C	Thread D
ABB-10SL-PGA-B	10SL	20,0 0.787	35,0 1.378	5/8" x 24 UNEF	PG 9
ABB-14S-PGA-B	14S - 14	23,5 0.925	35,0 1.378	3/4" x 20 UNEF	PG 9
ABB-16S-PGA-E	16S - 16	28,0 1.102	35,0 1.378	7/8" x 20 UNEF	PG 16
ABB-16S-PGA-F	16S - 16	34,0 1.339	40,0 1.575	7/8" x 20 UNEF	PG 21
ABB-18-PGA-F	18	34,0 1.339	40,0 1.575	1" x 20 UNEF	PG 21
ABB-20-PGA-E	20 - 22	37,0 1.457	35,0 1.378	1 3/16" x 18 UNEF	PG 16
ABB-20-PGA-G	20 - 22	43,0 1.693	40,0 1.575	1 3/16" x 18 UNEF	PG 29
ABB-24-PGA-F	24 - 28	43,0 1.693	40,0 1.575	1 7/16" x 18 UNEF	PG 21
ABB-24-PGA-G	24 - 28	43,0 1.693	40,0 1.575	1 7/16" x 18 UNEF	PG 29
ABB-24-PGA-H	24 - 28	54,0 2.126	46,0 1.811	1 7/16" x 18 UNEF	PG 36
ABB-32-PGA-H	32	54,0 2.126	38,0 1.496	1 3/4" x 18 UNS	PG 36
ABB-36-PGA-H	36	57,2 2.252	50,0 1.969	2" x 18 UNS	PG 36
ABB-40-PGA-J	40	65,0 2.559	51,0 2.008	2 1/4" x 16 UN	PG 42

Cable Clamp

Style: MS 3057A

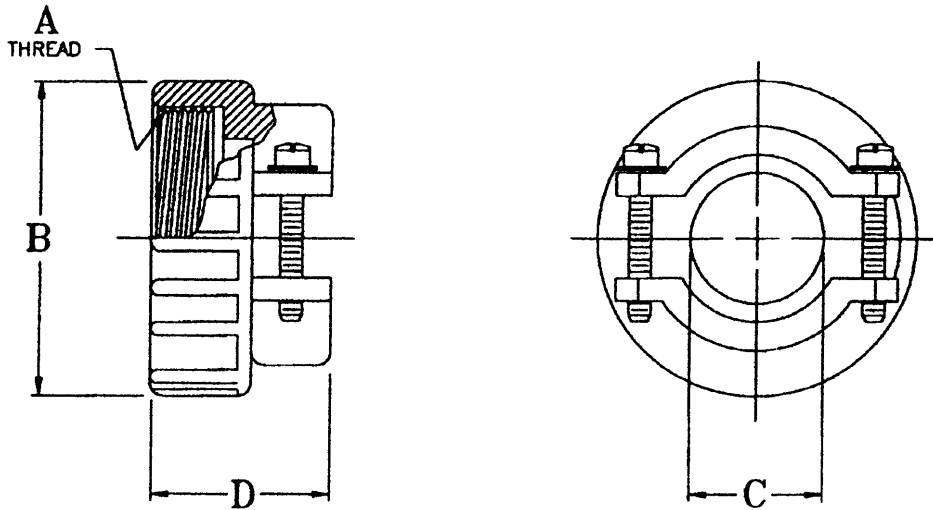

Metric
Imperial

Shell Size	MS3057 Reference	AB Connectors Part Number	A Thread Dia. Class 2A	B Max	C Max	D Max
10SL	-4A	CMSP3057A10SL	$\frac{5}{8}$ " x 24 UNEF	21,41 0.843	7,95 0.313	21,41 0.843
14S	-6A	CMSP3057A14S	$\frac{3}{4}$ " x 20 UNEF	25,40 1.000	11,13 0.438	23,01 0.906
16S	-8A	CMSP3057A16S	$\frac{7}{8}$ " x 20 UNEF	28,58 1.125	14,30 0.563	24,61 0.969
16	-8A	CMSP3057A16	$\frac{7}{8}$ " x 20 UNEF	28,58 1.125	14,30 0.563	24,61 0.969
18	-10A	CMSP3057A18	1" x 20 UNEF	30,96 1.219	15,88 0.625	24,61 0.969
20	-12A	CMSP3057A20	$1\frac{3}{16}$ " x 18 UNEF	35,71 1.406	19,05 0.750	24,61 0.969
22	-12A	CMSP3057A22	$1\frac{3}{16}$ " x 18 UNEF	35,71 1.406	19,05 0.750	24,61 0.969
24	-16A	CMSP3057A24	$1\frac{7}{16}$ " x 18 UNEF	42,85 1.687	23,83 0.938	26,97 1.062
28	-16A	CMSP3057A28	$1\frac{7}{16}$ " x 18 UNEF	42,85 1.687	23,83 0.938	26,97 1.062
32	-20A	CMSP3057A32	$1\frac{3}{4}$ " x 18 UNS	52,37 2.062	31,75 1.250	28,58 1.125
36	-24A	CMSP3057A36	2" x 18 UNS	57,15 2.250	34,93 1.375	30,15 1.187
40	-28A	CMSP3057A40	$2\frac{1}{4}$ " x 16 UN	64,29 2.531	41,28 1.625	43,66 1.719

Sealed Cable Clamp For Jacketed Cable

Style: MS 3057C

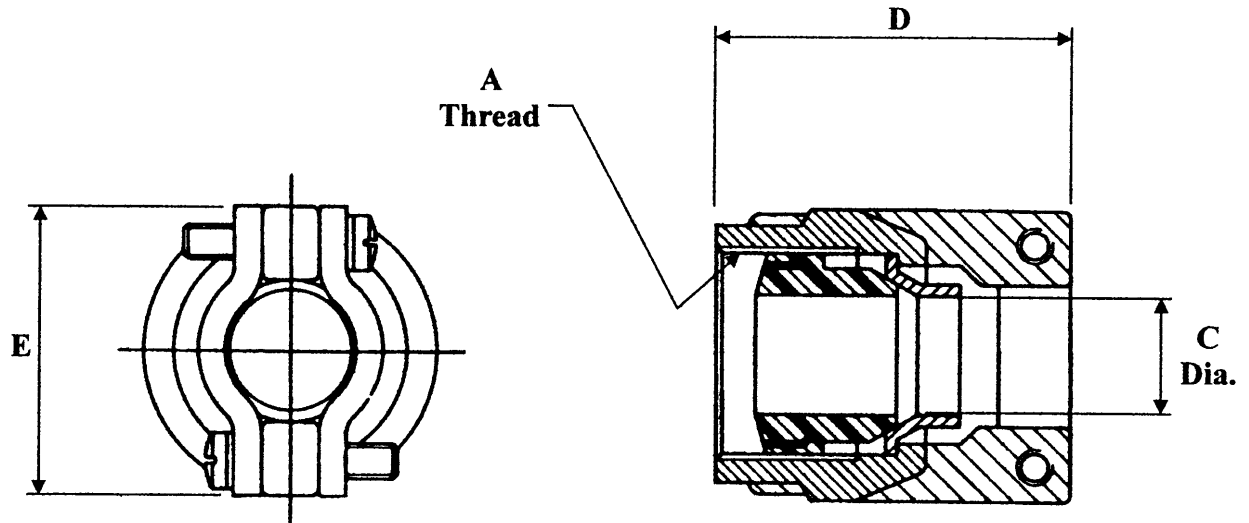

Metric
 Imperial

Shell Size	MS3057 Reference	AB Connectors Part Number	A Thread Dia. Class 2A	C Dia.		D Max	E Max
				Max	Min		
10SL	-4C	CMSP3057C10SL	$\frac{5}{8}$ " x 24 UNEF	7,93 0.312	2,38 0.094	34,93 1.375	23,80 0.937
14S	-6C	CMSP3057C14S	$\frac{3}{4}$ " x 20 UNEF	11,12 0.438	6,35 0.250	34,93 1.375	26,97 1.062
16S	-8C	CMSP3057C16S	$\frac{7}{8}$ " x 20 UNEF	13,48 0.531	7,92 0.312	34,93 1.375	30,18 1.188
16	-8C	CMSP3057C16	$\frac{7}{8}$ " x 20 UNEF	13,48 0.531	7,92 0.312	34,93 1.375	30,18 1.188
18	-10C	CMSP3057C18	1" x 20 UNEF	15,87 0.625	9,53 0.375	36,50 1.437	33,32 1.312
20	-12C	CMSP3057C20	$1\frac{1}{16}$ " x 18 UNEF	19,00 0.748	12,70 0.500	36,50 1.437	39,21 1.562
22	-12C	CMSP3057C22	$1\frac{3}{16}$ " x 18 UNEF	19,00 0.748	12,70 0.500	36,50 1.437	39,21 1.562
24	-16C	CMSP3057C24	$1\frac{7}{16}$ " x 18 UNEF	23,80 0.937	15,09 0.594	39,67 1.562	44,45 1.750
28	-16C	CMSP3057C28	$1\frac{7}{16}$ " x 18 UNEF	23,80 0.937	15,09 0.594	39,67 1.562	44,45 1.750
32	-20C	CMSP3057C32	$1\frac{3}{4}$ " x 18 UNS	31,75 1.250	23,83 0.938	46,02 1.812	57,15 2.250
36	-24C	CMSP3057C36	2" x 18 UNS	35,00 1.378	24,61 0.969	52,37 2.062	60,33 2.375
40	-28C	CMSP3057C40	$2\frac{1}{4}$ " x 16 UN	41,25 1.624	30,18 1.188	52,37 2.062	66,68 2.625

Telescopic Bushing

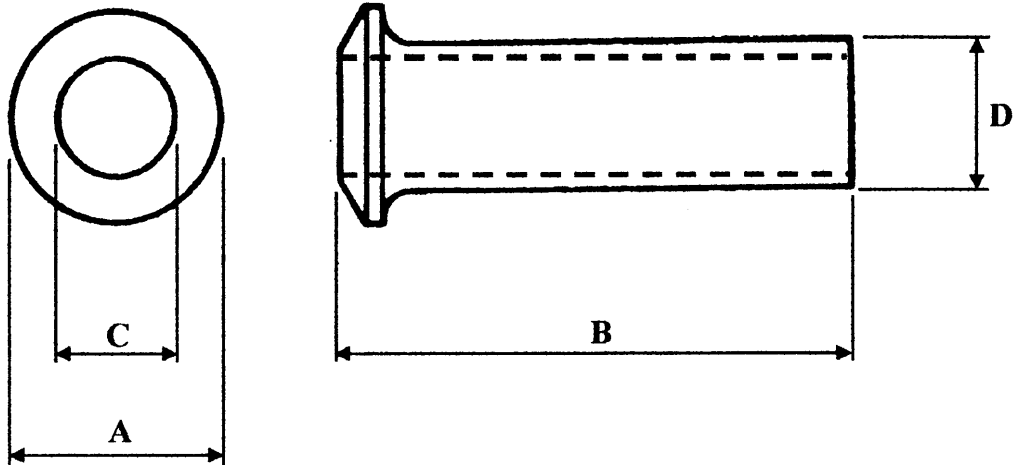

Note
 The bushings can fit inside one another to reduce the cable entry diameter to improve clamping and sealing.

Metric
 Imperial

Shell Size	Part Number	A	B	C	D
10SL	SBMSH5541	12,83 0.505	69,85 2.750	5,59 0.220	7,62 0.300
14S	SBMSH5542	15,88 0.625	66,68 2.625	7,92 0.312	10,80 0.425
16S	SBMSH5543	19,05 0.750	63,50 2.500	11,10 0.437	13,97 0.550
16	SBMSH5543	19,05 0.750	63,50 2.500	11,10 0.437	13,97 0.550
18	SBMSH5544	22,23 0.875	60,33 2.375	14,27 0.562	15,57 0.613
20	SBMSH5545	25,40 1.000	57,15 2.250	15,88 0.625	18,75 0.738
22	SBMSH5546	28,58 1.125	57,15 2.250	15,88 0.625	18,75 0.738
24	SBMSH5547	31,75 1.250	53,98 2.125	19,05 0.750	23,50 0.925
28	SBMSH5548	38,23 1.505	53,98 2.125	19,05 0.750	23,50 0.925
32	SBMSH5549	44,45 1.750	50,80 2.000	23,80 0.937	31,45 1.238
36	SBMSH55410	47,88 1.885	47,63 1.875	31,75 1.250	34,62 1.363
40	SBMSH55411	52,90 2.083	44,40 1.748	34,92 1.375	40,99 1.614

Panel Sealing Gaskets
Non-Screening, Sealing Only
RFI Conductive Screening & Sealing

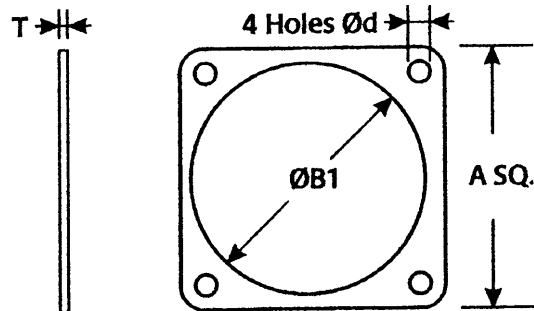
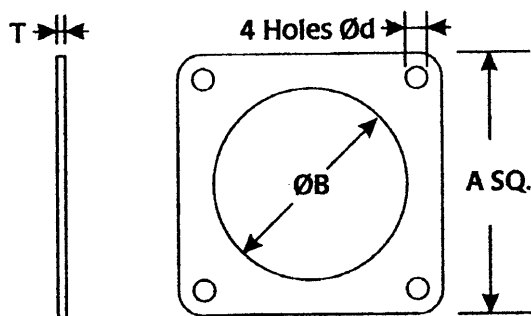

Front Mounted Receptacle
Part Number:
Non-Screening- SB - ** - RPG
RFI Screening- SB - ** - RPGS

Rear Mounted Receptacle
Part Number:
Non-Screening- SB - ** - FPG
RFI Screening- SB - ** - FPGS

Metric
 Imperial

Shell size	A Min	B Nominal	B1 Nominal	d Min	T Nominal
10SL	25,40 1.000	15,88 0.625	18,30 0.720	3,43 0.135	1,00 0.040
14S	30,20 1.188	19,00 0.750	24,70 0.972	3,43 0.135	1,00 0.040
16S	32,50 1.280	22,20 0.875	27,50 1.083	3,43 0.135	1,00 0.040
16	32,50 1.280	22,20 0.875	27,50 1.083	3,43 0.135	1,00 0.040
18	34,90 1.375	25,40 1.000	30,90 1.217	3,43 0.135	1,00 0.040
20	38,10 1.500	28,60 1.125	34,30 1.350	3,43 0.135	1,00 0.040
22	41,30 1.625	31,70 1.250	37,50 1.476	3,43 0.135	1,00 0.040
24	44,50 1.750	34,90 1.375	41,00 1.614	4,12 0.162	1,00 0.040
28	50,80 2.000	41,30 1.625	46,80 1.843	4,12 0.162	1,00 0.040
32	57,20 2.250	47,60 1.875	53,50 2.106	4,78 0.188	1,00 0.040
36	63,50 2.500	52,60 2.071	59,70 2.350	4,78 0.188	1,00 0.040
40	69,90 2.750	61,90 2.440	65,50 2.580	5,10 2.010	1,00 0.040
*49	110,00 4.331	98,10 3.862	98,10 3.862	7,90 0.311	1,25 0.049

* Available as non-screened version only.

Protective Caps

Styles: **ABBE-**-X-PCA / X-PCAK & X-PCAJ / X-PCAJK**

ABB--E-PCA / E-PCAK**

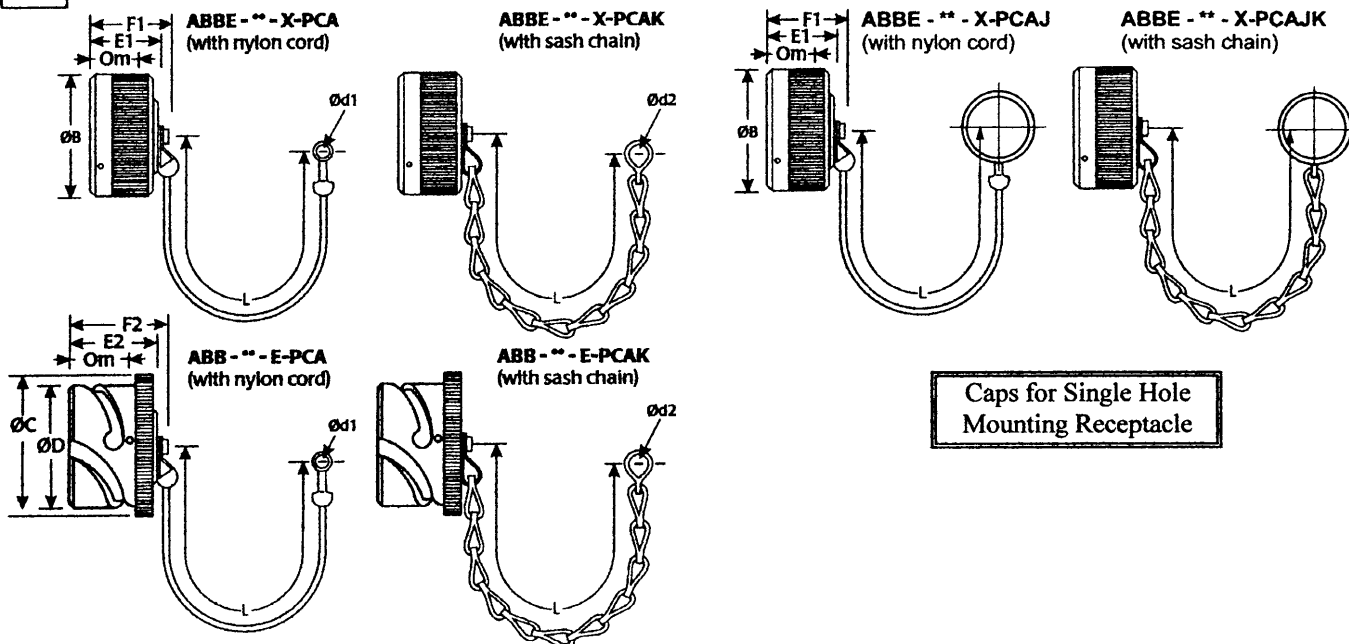

Metric
Imperial

Shell Size	B Max	C Max	D Max	E1 Max	E2 Max	F1 Max	F2 Max	L approx. See note	d1 Min	d2 +0.5, -0 +0.02, -0	Om Min Overlap Mated
10SL	22,80 0.898	26,10 1.028	18,20 0.717	17,50 0.689	21,60 0.850	24,60 0.969	28,40 1.118	100,00 4.000	4,85 0.191	4,30 0.169	11,10 0.437
14S	29,20 1.150	32,50 1.280	24,60 0.969	17,50 0.689	21,60 0.850	24,60 0.969	28,40 1.118	100,00 4.000	4,85 0.191	4,30 0.169	11,10 0.437
16S	32,40 1.276	35,30 1.390	27,40 1.079	17,50 0.689	21,60 0.850	24,60 0.969	28,40 1.118	100,00 4.000	4,85 0.191	4,30 0.169	11,10 0.437
16	32,40 1.276	35,30 1.390	27,40 1.079	24,00 0.945	27,30 1.075	24,60 0.969	28,40 1.118	100,00 4.000	4,85 0.191	4,30 0.169	15,85 0.624
18	36,50 1.437	38,70 1.524	30,80 1.213	24,00 0.945	27,30 1.075	29,80 1.173	33,90 1.335	150,00 6.000	4,85 0.191	4,30 0.169	15,85 0.624
20	39,90 1.571	42,10 1.658	34,20 1.346	24,00 0.945	27,30 1.075	29,80 1.173	33,90 1.335	150,00 6.000	4,85 0.191	4,30 0.169	15,85 0.624
22	43,10 1.697	45,30 1.784	37,40 1.472	24,00 0.945	27,30 1.075	29,80 1.173	33,90 1.335	150,00 6.000	4,85 0.191	4,30 0.169	15,75 0.620
24	46,60 1.835	48,80 1.921	40,90 1.610	24,00 0.945	27,30 1.075	29,80 1.173	33,90 1.335	150,00 6.000	4,85 0.191	4,30 0.169	15,75 0.620
28	53,40 2.102	54,60 2.150	46,70 1.838	24,00 0.945	27,30 1.075	29,80 1.173	33,90 1.335	150,00 6.000	4,85 0.191	4,30 0.169	15,75 0.620
32	60,10 2.366	61,30 2.413	53,40 2.102	27,00 1.063	27,30 1.075	29,80 1.173	33,90 1.335	150,00 6.000	4,85 0.191	5,50 0.217	15,75 0.620
36	66,30 2.610	67,50 2.658	59,60 2.346	27,00 1.063	27,30 1.075	29,80 1.173	33,90 1.335	150,00 6.000	4,85 0.191	5,50 0.217	15,75 0.620
40	72,10 2.838	73,40 2.890	65,50 2.579	27,00 1.063	27,30 1.075	29,80 1.173	33,90 1.335	150,00 6.000	4,85 0.191	5,50 0.217	15,75 0.620

Note. For alternative cord or chain length, please consult the factory.

Individual Wire Seal Grommet

Dummy Pin, Socket & Grommet Filler Plug

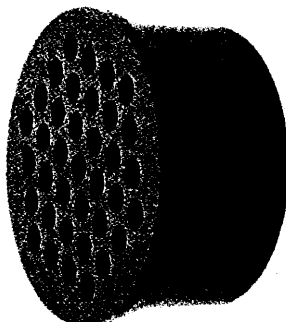

Metric
Imperial

How to order:

ABBH - ** - ** - GAC - F80

Shell size

Contact arrangement

F80 Contact Sizes AWG (Metric)	*Wire Insulation Min O/D	*Wire Insulation Max O/D
16S/16 (15S/15)	1,52 0.060	3,20 0.126
12 (25)	2,44 0.096	5,12 0.202
8 (100)	4,90 0.193	7,20 0.283
4 (160)	8,18 0.322	11,00 0.433
**0 (500)	14,00 0.551	16,00 0.630

* Please contact sales office for further detail.

** For details of grommet reducing bushes to suit 35mm², 25mm² & 16mm² wire, please contact the sales office.

Grommet Filler Plug

Dummy Pin

Dummy Socket

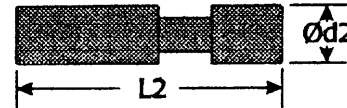
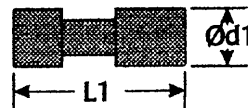
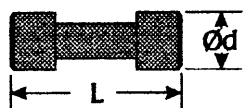

Metric
Imperial

ABB - ** - KFP F80

ABB - ** - KDP F80

ABB - ** - KDS F80

Contact Size AWG (Metric)	L Max	d Max	L1 Max	d1 Max	L2 Max	d2 Max	Colour Code
***16S (15S)	12,30 0.484	3,90 0.154	20,40 0.803	3,20 0.126	26,85 1.057	3,20 0.126	Pink
***16 (15)	12,30 0.484	3,90 0.154	20,00 0.787	3,20 0.126	36,75 1.447	3,20 0.126	Brown (KDP/KDS)
12 (25)	12,30 0.484	3,80 0.150	20,40 0.803	4,80 0.189	37,75 1.486	4,80 0.189	Orange
8 (100)	12,10 0.476	7,00 0.276	22,75 0.896	7,80 0.307	40,95 1.612	7,80 0.307	Violet
4 (160)	12,10 0.476	10,20 0.402	*	*	*	*	Black
0 (500)	12,50 0.500	15,60 0.614	24,60 0.969	15,00 0.590	44,70 1.760	15,00 0.590	White

***For Grommet Filler Plugs (KFP), do not add F80 to part number. Colour Blue.

* Please consult factory for availability.

Square Flange Stowage Receptacle

Style: ABCIR - ** - SX / SX - M6

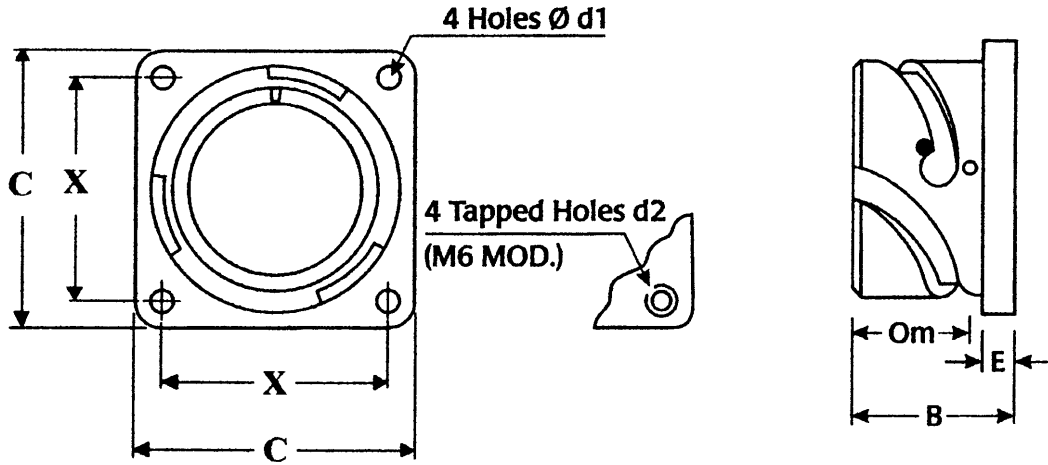

Metric
Imperial

See page 79 for panel
mounting details

Part Number	B Max	C Max	D1 Min	d2 Thread	E Max	X	Om min overlap mated
ABCIR-10SL-SX	17,60 0.693	25,70 1.012	3,20 0.126	M4	3,00 0.118	18,20 0.717	11,10 0.437
ABCIR-14S-SX	18,00 0.709	30,30 1.193	3,20 0.126	M4	3,40 0.134	23,10 0.909	11,10 0.437
ABCIR-16S-SX	18,00 0.709	32,80 1.291	3,20 0.126	M4	3,40 0.134	24,60 0.969	11,10 0.437
ABCIR-16-SX	22,80 0.898	32,80 1.291	3,20 0.126	M4	3,40 0.134	24,60 0.969	15,85 0.624
ABCIR-18-SX	23,60 0.929	35,30 1.390	3,20 0.126	M4	4,20 0.165	27,00 1.063	15,85 0.624
ABCIR-20-SX	23,60 0.929	38,30 1.508	3,20 0.126	M4	4,20 0.165	29,40 1.157	15,85 0.624
ABCIR-22-SX	23,60 0.929	41,30 1.626	3,20 0.126	M4	4,20 0.165	31,80 1.252	15,75 0.620
ABCIR-24-SX	25,20 0.992	44,80 1.764	3,70 0.146	M4	4,20 0.165	34,90 1.374	15,75 0.620
ABCIR-28-SX	25,20 0.992	51,10 2.012	3,70 0.146	M5	4,20 0.165	39,70 1.563	15,75 0.620
ABCIR-32-SX	26,80 1.055	57,30 2.256	4,30 0.169	M5	4,20 0.165	44,50 1.752	15,75 0.620
ABCIR-36-SX	26,80 1.055	63,80 2.512	4,30 0.169	M5	4,20 0.165	49,20 1.937	15,75 0.620
ABCIR-40-SX	26,80 1.055	70,20 2.763	4,30 0.169	M5	4,20 0.165	55,50 2.185	15,75 0.620
ABCIR-49-SX	56,73 2.233	110,40 4.346	8,50 0.335	-	8,20 0.323	90,00 3.543	

Square Flange Receptacle

Nut Plates

Style: ABB ** NP (Metric Thread) / NPA (UNC Thread)

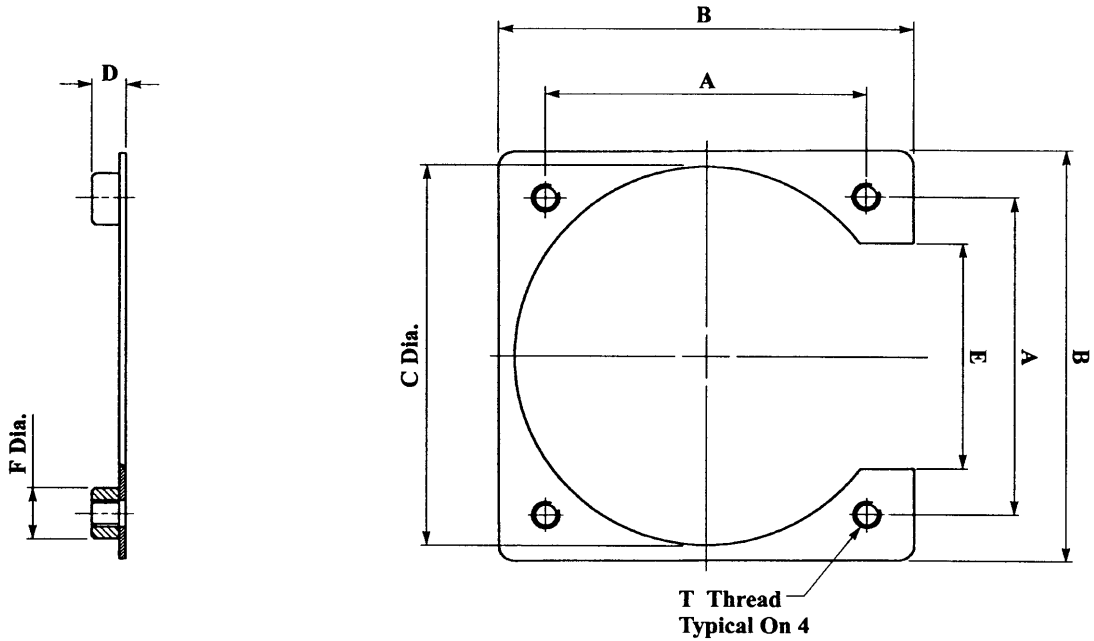

Metric
Imperial

Shell Size	A	B Max	C Dia. Max	D	E Max	F Dia. Max	T Thread	Part Number	T Thread	Part Number
10SL	18,26 0.719	26,26 1.034	17,85 0.702	2,69/4,22 0.106/0.166	11,50 0.453	6,00 0.236	M3 x 0,5	ABB10SLNP	4 - 40 UNC	ABB10SLNPA
14S	23,01 0.906	30,66 1.207	24,59 0.968	2,69/4,22 0.106/0.166	16,25 0.640	6,00 0.236	M3 x 0,5	ABB14SNP	4 - 40 UNC	ABB14SNPA
16S	24,61 0.969	32,26 1.270	28,17 1.109	2,69/4,22 0.106/0.166	17,85 0.703	6,00 0.236	M3 x 0,5	ABB16SNP	4 - 40 UNC	ABB16SNPA
16	24,61 0.969	32,26 1.270	28,17 1.109	2,69/4,22 0.106/0.166	17,85 0.703	6,00 0.236	M3 x 0,5	ABB16NP	4 - 40 UNC	ABB16NPA
18	26,97 1.062	34,62 1.363	30,48 1.250	2,69/4,22 0.106/0.166	20,21 0.796	6,00 0.236	M3 x 0,5	ABB18NP	4 - 40 UNC	ABB18NPA
20	29,36 1.156	38,48 1.515	33,53 1.320	2,69/4,22 0.106/0.166	22,47 0.885	6,00 0.236	M3 x 0,5	ABB20NP	4 - 40 UNC	ABB20NPA
22	31,75 1.250	40,84 1.608	36,65 1.443	2,69/4,22 0.106/0.166	23,54 0.927	6,00 0.236	M3 x 0,5	ABB22NP	4 - 40 UNC	ABB22NPA
24	34,93 1.375	44,83 1.765	40,00 1.575	2,69/4,22 0.106/0.166	25,90 1.020	7,50 0.295	M3 x 0,5	ABB24NP	4 - 40 UNC	ABB24NPA
28	39,67 1.562	51,18 2.015	46,61 1.835	2,69/4,22 0.106/0.166	29,08 1.145	7,50 0.295	M3 x 0,5	ABB28NP	4 - 40 UNC	ABB28NPA
32	44,45 1.750	59,10 2.327	52,75 2.077	3,50/5,00 0.138/0.197	30,68 1.208	8,00 0.315	M4 x 0,7	ABB32NP	8 - 32 UNC	ABB32NPA
36	49,23 1.968	63,86 2.514	59,10 2.327	3,50/5,00 0.138/0.197	35,43 1.395	8,00 0.315	M4 x 0,7	ABB36NP	8 - 32 UNC	ABB36NPA
40	55,58 2.188	74,68 2.940	68,33 2.690	3,50/5,00 0.138/0.197	38,60 1.520	8,00 0.315	M4 x 0,7	ABB40NP	8 - 32 UNC	ABB40NPA

Square Flange Receptacles Panel Mounting Detail

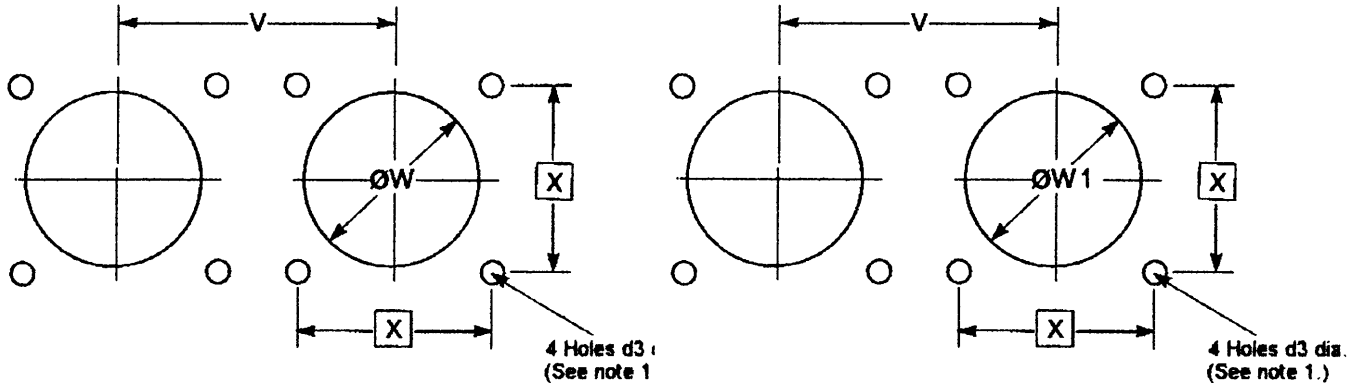

**Front Mounting: Style ABCIRH00
ABCIRH04
ABCIRH12A**

**Rear Mounting: Style ABCIRH03
ABCIRH05 & 07**

**Metric
Imperial**

Note 1.
When fixed connectors are used with threaded mounting holes, refer to hole sizes in column d4.

Note 2.
When fixed connectors are used with plugs having rubber coupling nuts, please consult factory for panel cut-out dimensions.

Shell size	d3 dia.	d4 dia.	V	W	W1	X
10SL	3,40 0.134	4,50 0.177	26,60 1.047	17,00 0.670	18,58 0.732	18,20 0.717
14S	3,40 0.134	4,50 0.177	31,60 1.244	20,00 0.780	24,98 0.984	23,00 0.906
16S	3,40 0.134	4,50 0.177	34,40 1.354	23,00 0.906	27,78 1.094	24,60 0.969
16	3,40 0.134	4,50 0.177	34,40 1.354	23,00 0.906	27,78 1.094	24,60 0.969
18	3,40 0.134	4,50 0.177	38,30 1.508	26,00 1.024	31,18 1.228	27,00 1.063
20	3,40 0.134	4,50 0.177	41,70 1.642	30,00 1.181	34,58 1.361	29,40 1.157
22	3,40 0.134	4,50 0.177	45,20 1.780	33,00 1.300	37,78 1.487	31,80 1.252
24	3,90 0.154	4,50 0.177	48,70 1.917	36,00 1.417	41,28 1.625	34,90 1.374
28	3,90 0.154	5,50 0.217	55,50 2.185	42,00 1.654	47,08 1.854	39,70 1.563
32	4,50 0.177	5,50 0.217	62,40 2.475	48,50 1.909	53,78 2.117	44,50 1.752
36	4,50 0.177	5,50 0.217	69,00 2.717	55,00 2.165	59,98 2.361	49,20 1.937
40	4,50 0.177	5,50 0.217	75,00 2.953	59,10 2.327	66,4 2.614	55,50 2.186
49	8,50 0.315	-	140,00 5.512	91,00 3.583	91,00 3.583	90,00 3.543

Single Hole Mounting Receptacle Panel Mounting Detail

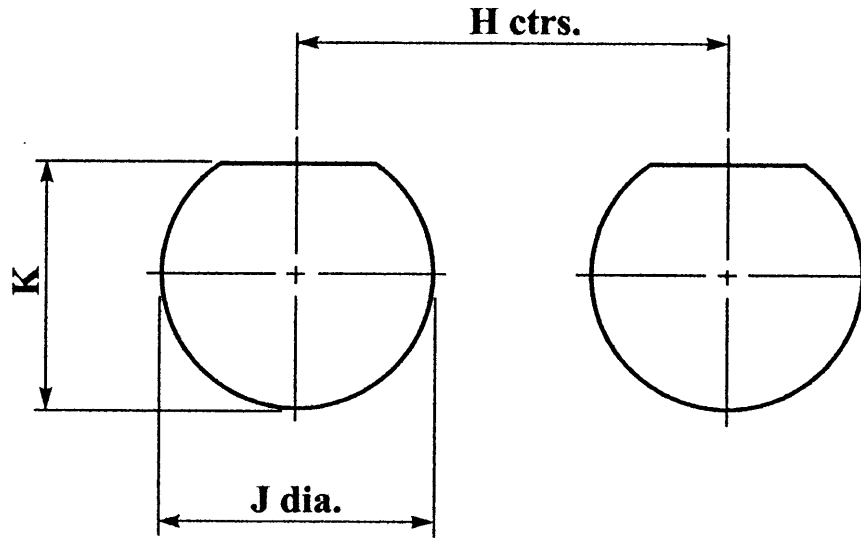

Metric
Imperial

Note.
When fixed connectors are used with plugs having rubber coupling nuts, please consult factory for panel cut-out dimensions.

Shell Size	H ctrs.	J dia.	K
10SL	32,55 1.281	22,53 0.887	20,83 0.820
14S	42,05 1.656	28,88 1.137	27,23 1.072
16S	45,15 1.776	32,08 1.263	30,78 1.212
16	45,15 1.776	32,08 1.263	30,78 1.212
18	48,85 1.923	35,23 1.387	33,58 1.322
20	52,05 2.049	38,43 1.513	36,68 1.444
22	55,45 2.183	41,56 1.636	39,88 1.570
24	58,45 2.301	44,78 1.763	43,18 1.700
28	65,25 2.569	51,13 2.013	49,37 1.944
32	71,55 2.817	57,48 2.263	55,78 2.196
36	77,95 3.069	63,83 2.513	62,18 2.448
40	85,25 3.356	70,18 2.763	68,38 2.692

F80 Crimp Contacts

Insertion & Extraction Tools

Socket Contact Guide Pins

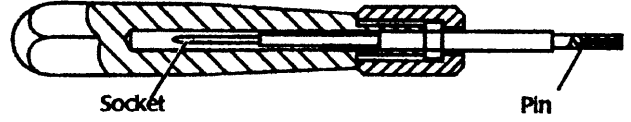
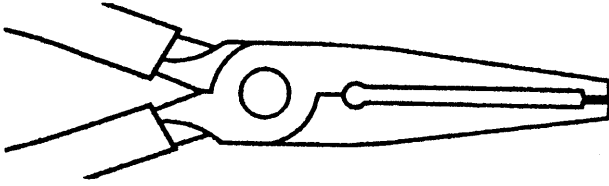

Insertion Tool

Contact Size AWG (Metric)	Insertion Tool Part Number
16 (16S)	ABB-IT-16
16 (15)	ABB-IT-16
12 (25)	ABB-IT-12
8 (100)	Tool Not Required
4 (160)	
0 (500)	

Extraction Tool

Contact Size AWG (Metric)	Extraction Tool Part Number
16 (16S)	ABB-ET-16
16 (15)	ABB-ET-16
12 (25)	ABB-ET-12
8 (100)	Tool Not Required
4 (160)	
0 (500)	

Socket Contact Guide Pin

Socket Contact Size AWG (Metric)	Guide Pin Part Number
16 (16S)	ABB-16-SGP
16 (15)	ABB-16-SGP
12 (25)	ABB-12-SGP
8 (100)	Guide Pin Not Required
4 (160)	
0 (500)	

Note.
For full assembly instructions, see AB
Specification 514.
Contact the sales office for a copy.

F80 Contacts

Crimp & Tooling Data

Contact Size & Type	Contact Part Number	Wire Size C.S.A. mm ²	Tool Required	Turret/Locator	Tool Setting	Tool Pos'n If Applicable	Insertion Tool	Extraction Tool	Guide Pins
16S/20 Pin	ABB16S/20KPKF80	0,5/0,75	AF8/WA27F	TP1249	3	-	ABBIT16	ABBET16	-
16S/20 Skt.	ABB16S/20KSKF80	0,5/0,75	AF8/WA27F	TP1249	3	-	ABBIT16	ABBET16	ABB16SGP
16S/18 Pin	ABB16S/18KPKF80	0,75/0,93	AF8/WA27F	TP1249	4	-	ABBIT16	ABBET16	-
16S/18 Skt.	ABB16S/18KSKF80	0,75/0,93	AF8/WA27F	TP1249	4	-	ABBIT16	ABBET16	ABB16SGP
16S/14 Pin	ABB16S/14KPKF80	1,94/2,08	AF8/WA27F	TP1249	5	-	ABBIT16	ABBET16	-
16S/14 Skt.	ABB16S/14KSKF80	1,94/2,08	AF8/WA27F	TP1249	5	-	ABBIT16	ABBET16	ABB16SGP
16S Pin	ABB16SKPKF80	0,93/1,5	AF8/WA27F	TP1249	5	-	ABBIT16	ABBET16	-
16S Skt.	ABB16SKSKF80	0,93/1,5	AF8/WA27F	TP1249	5	-	ABBIT16	ABBET16	ABB16SGP
LIF 16S Skt.	ABB16SKLKF80	0,93/1,5	AF8/WA27F	TP1249	5	-	ABBIT16	ABBET16	ABB16SGP
16/22 Pin	ABB16/22KPKF80	0,22/0,34	AF8/WA27F	TH592	2/3	Red	ABBIT16	ABBET16	-
16/22 Skt.	ABB16/22KSKF80	0,22/0,34	AF8/WA27F	TH592	2/3	Blue	ABBIT16	ABBET16	ABB16SGP
16/20 Pin	ABB16/20KPKF80	0,5/0,75	AF8/WA27F	TH592	3	Blue	ABBIT16	ABBET16	-
16/20 Skt.	ABB16/20KSKF80	0,5/0,75	AF8/WA27F	TH592	3	Red	ABBIT16	ABBET16	ABB16SGP
LIF 16/20 Skt.	ABB16/20KLF80	0,5/0,75	AF8/WA27F	TH592	3	Red	ABBIT16	ABBET16	ABB16SGP
16/18 Pin	ABB16/18KPKF80	0,75/0,93	AF8/WA27F	TH592	4	Blue	ABBIT16	ABBET16	-
16/18 Skt.	ABB16/18KSKF80	0,75/0,93	AF8/WA27F	TH592	4	Red	ABBIT16	ABBET16	ABB16SGP
16 Pin	ABB16KPKF80	0,93/1,5	AF8/WA27F	TH592	5	Blue	ABBIT16	ABBET16	-
16 Skt.	ABB16KSKF80	0,93/1,5	AF8/WA27F	TH592	5	Red	ABBIT16	ABBET16	ABB16SGP
LIF 16 Skt.	ABB16KLF80	0,93/1,5	AF8/WA27F	TH592	5	Red	ABBIT16	ABBET16	ABB16SGP
16/14 Pin	ABB16/14KPKF80	1,94/2,08	AF8/WA27F	TH592	5	Blue	ABBIT16	ABBET16	-
16/14 Skt.	ABB16/14KSKF80	1,94/2,08	AF8/WA27F	TH592	5	Red	ABBIT16	ABBET16	ABB16SGP
16/12 Pin	ABB16/12KPKF80	2,50/3,00	AF8/WA27F	TH592	7	Yellow	ABBIT16	ABBET16	-
16/12 Skt.	ABB16/12KSKF80	2,50/3,00	AF8/WA27F	TH592	7	Yellow	ABBIT16	ABBET16	ABB16SGP
12/20 Pin	ABB12/20KPKF80	0,5/0,75	AF8/WA27F	TH592	3	Yellow	ABBIT12	ABBET12	-
12/20 Skt.	ABB12/20KSKF80	0,5/0,75	AF8/WA27F	TH592	3	Yellow	ABBIT12	ABBET12	ABB12SGP
LIF 12/20 Skt.	ABB12/20KLF80	0,5/0,75	AF8/WA27F	TH592	3	Yellow	ABBIT12	ABBET12	ABB12SGP
12/18 Pin	ABB12/18KPKF80	0,75/0,93	AF8/WA27F	TH592	4	Yellow	ABBIT12	ABBET12	-
12/18 Skt.	ABB12/18KSKF80	0,75/0,93	AF8/WA27F	TH592	4	Yellow	ABBIT12	ABBET12	ABB12SGP
12/16 Pin	ABB12/16KPKF80	0,93/1,5	AF8/WA27F	TH592	5	Yellow	ABBIT12	ABBET12	-
12/16 Skt.	ABB12/16KSKF80	0,93/1,5	AF8/WA27F	TH592	5	Yellow	ABBIT12	ABBET12	ABB12SGP
LIF 12/16 Skt.	ABB12/16KLF80	0,93/1,5	AF8/WA27F	TH592	5	Yellow	ABBIT12	ABBET12	ABB12SGP
12/14 Pin	ABB12/14KPKF80	1,94/2,08	AF8/WA27F	TH592	5	Yellow	ABBIT12	ABBET12	-
12/14 Skt.	ABB12/14KSKF80	1,94/2,08	AF8/WA27F	TH592	5	Yellow	ABBIT12	ABBET12	ABB12SGP
12 Pin	ABB12KPKF80	2,50/3,00	AF8/WA27F	TH592	7	Yellow	ABBIT12	ABBET12	-
12 Skt.	ABB12KSKF80	2,50/3,00	AF8/WA27F	TH592	7	Yellow	ABBIT12	ABBET12	ABB12SGP
LIF 12 Skt.	ABB12KLF80	2,50/3,00	AF8/WA27F	TH592	7	Yellow	ABBIT12	ABBET12	ABB12SGP
12/10 Pin	ABB12/10KPKF80	5,53	M310	TH592	5	Yellow	ABBIT12	ABBET12	-
12/10 Skt.	ABB12/10KSKF80	5,53	M310	TH592	5	Yellow	ABBIT12	ABBET12	ABB12SGP
12/40 Pin	ABB12/40KPKF80	4,0	M310	TH592	5	Yellow	ABBIT12	ABBET12	-
12/40 Skt.	ABB12/40KSKF80	4,0	M310	TH592	5	Yellow	ABBIT12	ABBET12	ABB12SGP

F80 Contacts

Crimp & Tooling Data cont.

Contact Size & Type	Contact Part Number	Wire Size C.S.A. mm ²	Tool Required	Turret/ Locator	Tool Setting	Tool Pos'n If Applicable	Insertion Tool	Extraction Tool	Guide Pins
8/40 Pin	ABB8/40KPKF80	4,0	D55E	Die Set MRP31042	-	-	-	-	-
8/40 Skt.	ABB8/40KSKF80	4,0	D55E	Die Set MRP31042	-	-	-	-	-
8/12 Pin	ABB8/12KPKF80	2,5	M310	Consult Factory	3	-	-	-	-
8/12 Skt.	ABB8/12KSKF80	2,5	M310	Consult Factory	3	-	-	-	-
8/10 Pin	ABB8/10KPKF80	5,53	D55E	Die Set MRP31042	-	-	-	-	-
8/10 Skt.	ABB8/10KSKF80	5,53	D55E	Die Set MRP31042	-	-	-	-	-
8 Pin	ABB8KPKF80	9,0	ERMA 19600	22390	-	-	-	-	-
8 Skt.	ABB8KSKF80	9,0	ERMA 19600	22390	-	-	-	-	-
100/60 Pin	ABB100/60KPKF80	6,0	D55E	Die Set MRP31038	-	-	-	-	-
100/60 Skt.	ABB100/60KSKF80	6,0	D55E	Die Set MRP31038	-	-	-	-	-
100 Pin	ABB100KPKF80	10,0	D55E	Die Set MRP0925	-	-	-	-	-
100 Skt.	ABB100KSKF80	10,0	D55E	Die Set MRP0925	-	-	-	-	-
4/10 Pin	ABB4/10KPKF80	5,53	D55E	Die Set MRP31042	-	-	-	-	-
4/10 Skt.	ABB4/10KSKF80	5,53	D55E	Die Set MRP31042	-	-	-	-	-
4 Pin	ABB4KPKF80	22,0	ERMA 19600	Die set 22391	-	-	-	-	-
4 Skt.	ABB4KSKF80	22,0	ERMA 19600	Die Set 22391	-	-	-	-	-
160 Pin	ABB160KPKF80	16,0	D55E	Die Set MRP0924	-	-	-	-	-
160 Skt.	ABB160KSKF80	16,0	D55E	Die Set MRP0924	-	-	-	-	-
0 Pin	ABB0KPKF80	53,0	ERMA 19600	Die Set 22392	-	-	-	-	-
0 Skt	ABB0KSKF80	53,0	ERMA 19600	Die Set 22392	-	-	-	-	-
500/160 Pin	ABB500/160KPKF80	16,0	D55E	Die Set MRP0924	-	-	-	-	-
500/160 Skt.	ABB500/160KSKF80	16,0	D55E	Die Set MRP0924	-	-	-	-	-
500/250 Pin	ABB500/250KPKF80	25,0	D55E	Die Set MRP31041	-	-	-	-	-
500/250 Skt.	ABB500/250KSKF80	25,0	D55E	Die Set MRP31041	-	-	-	-	-
500/350 Pin	ABB500/350KPKF80	35,0	D55E	Die Set MRP31038	-	-	-	-	-
500/350 Skt.	ABB500/350KSKF80	35,0	D55E	Die Set MRP31038	-	-	-	-	-
500 Pin	ABB500KPKF80	50,0	D55E	Die Set MRP0925	-	-	-	-	-
500 Skt.	ABB500KSKF80	50,0	D55E	Die Set MRP0925	-	-	-	-	-

Note.

For full assembly and wiring instructions for ABCIRH connectors, see AB Specification 514.

To obtain a copy, please contact the Sales Office.



F80 Coax & Twinax Contacts

Crimp & Tooling Data

Contact Size & Type	Contact Part Number	Wire Size C.S.A. mm ²	Contact Section	Tool Required	Turret/Locator	Tool Setting	Tool Position If Applicable
4 Coax Pin	ABB4CKPKF80P1001	0.5	Inner	AF8	TH619	4	Red
			Screen	D55E/D51	31038	-	-
4 Coax Skt	ABB4CKSKF80P1001	0.5	Inner	AF8	TH619	4	Blue
			Screen	D55E/D51	31038	-	-
4 Coax Pin	ABB4CKPKF80P1002	1.0	Inner	AF8	TH619	4	Red
			Screen	D55E/D51	HD51-150	-	-
4 Coax Skt.	ABB4CKSKF80P1002	1.0	Inner	AF8	TH619	4	Blue
			Screen	D55E/D51	HD51-150	-	-
4 Twinax Pin	ABB4TKPKF80P1	0.5/0.6	Inner	AF8	TH608	4	Red
			Intermediate	HX4	Y946	-	-
			Screen	D55E/D51	HD51-150	-	-
4 Twinax Skt	ABB4TKSKF80P1	0.5/0.6	Inner	AF8	TH608	4	Blue
			Intermediate	HX4	Y946	-	-
			Screen	D55E/D51	HD51-150	-	-
4 Twinax Pin	ABB4TKPKF80P1001	0.75/1.0	Inner	AF8	TH608	4	Red
			Intermediate	HX4	Y946	-	-
			Screen	D55E/D51	HD51-150	-	-
4 Twinax Skt.	ABB4TKSKF80P1001	0.75/1.0	Inner	AF8	TH608	4	Blue
			Intermediate	HX4	Y946	-	-
			Screen	D55E/D51	HD51-150	-	-

Note.

For full assembly and wiring instructions for Coax & Twinax contacts, see AB Specification 525.

To obtain a copy, please contact the Sales Office.



Product Safety Information

Product Safety

The connectors referred to in this catalogue may be safely used within the special ratings and environment for which they have been designed.

However, they comprise a complex build of different materials including metals and plastics which themselves are plated and cleaned with various chemical compounds during the assembly process.

It is important to understand that hazards can occur if connectors are used:-

1. Outside the specified design criteria and/or incorrectly integrated into equipment.
2. When damaged in use, assembly, transit or storage.
3. Incorrectly wired or assembled.
4. Where the quality of installation is below the standard required to maintain and uphold good practice.
5. Where good housekeeping is not observed during use, assembly, transit or storage and allowing contamination from debris and fluids etc.

Safety Rules

1. Ensure all conductors & wires are capable of withstanding the electrical and environmental conditions of the application.
2. Always use the correct tools for cables, contacts and connectors.
3. Make circuit resistance checks before making a circuit live.
4. Always protect line circuits and **never** demate a live connector.
5. Never use a damaged connector.
6. Never burn discarded connectors or cable.
7. **IF IN DOUBT ASK.**

NB: Electrical safety factors are the responsibility of the user.

Note.

The company reserves the right and may change or vary specification without prior written notice.

U.K. Headquarters

AB Connectors Limited
Abercynon
Mountain Ash
Mid Glamorgan
CF45 4SF
U.K.

Tel. # 44 (0) 1443 740331
Fax. # 44 (0) 1443 741676

Internet - <http://www.ttabconnectors.com>
E-mail - sales@ttabconnectors.com

A TT Group Company

U.S.A. Manufacturing & Sales

AB Connectors Division
Business US 70 East
Smithfield NC 27577
U.S.A.

Tel.: 919 934 5181
Fax.: 919 934 5186

E-mail - abconnectors@abautomotiveusa.com

A TT Group Company