



AppBox E54 System User's Guide



Specializes in
designing with
Microchip
products

Notice !

Spectrum Digital, Inc (SDI) provides the enclosed product under the following conditions:

The user/customer assumes all responsibility and liability for the proper use, storage, and safe handling of the product. Further, the user indemnifies SDI from all claims arising from the use, installation, storage, and handling of the product. Due to the flexibility and open construction of the product, it is the user's responsibility to take all appropriate precautions with regard to powering, attachment of cables, connection to other equipment, and electrostatic discharge.

Except to the extent of the indemnity set forth above, neither party shall be liable to the other for any indirect, special, incidental, or consequential damages.

SDI assumes no liability for applications assistance, customer product design, system and software performance, or infringements of patents or services described herein.

No license is granted under any patent right or other intellectual property right of SDI covering or relating to any machines, process, software, or combination in which such SDI products or services might be or are used.

SDI currently with a variety of customer for products, and therefore our arrangement with the resellers, customer, or user **is not exclusive**.

Please refer to the product web page on the SDI web site for warranty period.

The warranty and return policy are described on the SDI web site.

Mailing address:

Spectrum Digital, Inc
PO Box 1559
Sugar Land, TX. 77487-1559

Web site: www.spectrumdigital.com
Sales: sales@spectrumdigital.com
Support: support@spectrumdigital.com

Copyright Spectrum Digital Inc, © 2020

519198-4001

Table of Contents

Section	Title	Page
1.0	Introduction	4
1.1	AppBox E54 Features	4
1.2	What's Included In The AppBox E54	5
1.3	AppBox E54 Front Panel	5
1.4	AppBox E54 Accessories	5
1.5	AppBox E54 Communication Expansion	6
1.6	AppBox E54 Software Development Tools	6
2.0	Installation	7
2.1	Attaching Power to the AppBox E54	7
2.2	Installation of AppIO Modules	8
2.3	Attachment of the Distribution Box to the AppBox E54	9
2.4	Installation of Atmel-ICE	10
3.0	Interfaces	11
3.1	Connectors	13
3.1.1	J1, Power Connector	13
3.1.2	J2, RS485, CAN Connector	14
3.1.3	J3, USB Connector	15
3.1.4	J4, Ethernet Connector	15
3.1.5	J5, SD Card Connector	16
3.1.6	J6, Cortex-M Debug Connector	16
3.1.7	AppIO Module Connectors	17
3.1.7.1	EXT1, AppIO Module 1 Connector	18
3.1.7.2	EXT2, AppIO Module 2 Connector	19
3.1.7.3	EXT3, AppIO Module 3 Connector	20
3.2	Jumpers	21
3.3	Switches	23
3.4	LEDs	24
3.5	Test Points	24
4.0	Physical Characteristics	24
5.0	Mechanical Information	25
6.0	Schematics	25

1.0 Introduction

This document describes the features of the AppBox E54. The AppBox E54 is designed to be used in an industrial environment with a CAN, RS485, USB, or Ethernet interface to provide flexible, modular I/O (AppIO) for specific applications. These AppIO Modules allow customized solutions to be integrated for a wide variety of applications that need to go into a CAN, RS485, USB, or Ethernet communications environment.

1.1 AppBox E54 Features

This AppBox E54 has the following features:

- Atmel ATSAME54P20A-AU processor (ARM Cortex-M4), maximum frequency 120 MHz.
- Operates on +12 to +24 volts DC, with Backup Supercapacitor
- CAN interface for industrial systems
- RS485 communications for industrial systems
- Communication interface expansion via Distribution Box (sold separately)
- Provides USB communications for computer based industrial applications
- Provides Ethernet communications for industrial IoT applications
- 256KB RAM, 1 MB Flash
- SD card memory connector for storage and logging
- Modular I/O expansion via up to three (3) AppIO Modules, Atmel X PLAINED compatible
- Fully enclosed system with knock out panels for AppIO Modules (sold separately)
- Convenient enclosure mounting holes
- Vented enclosure for cooling
- Front panel push button switch
- Front panel programmable LED
- Atmel-ICE debug header present for development
- Operates 0 - +70C

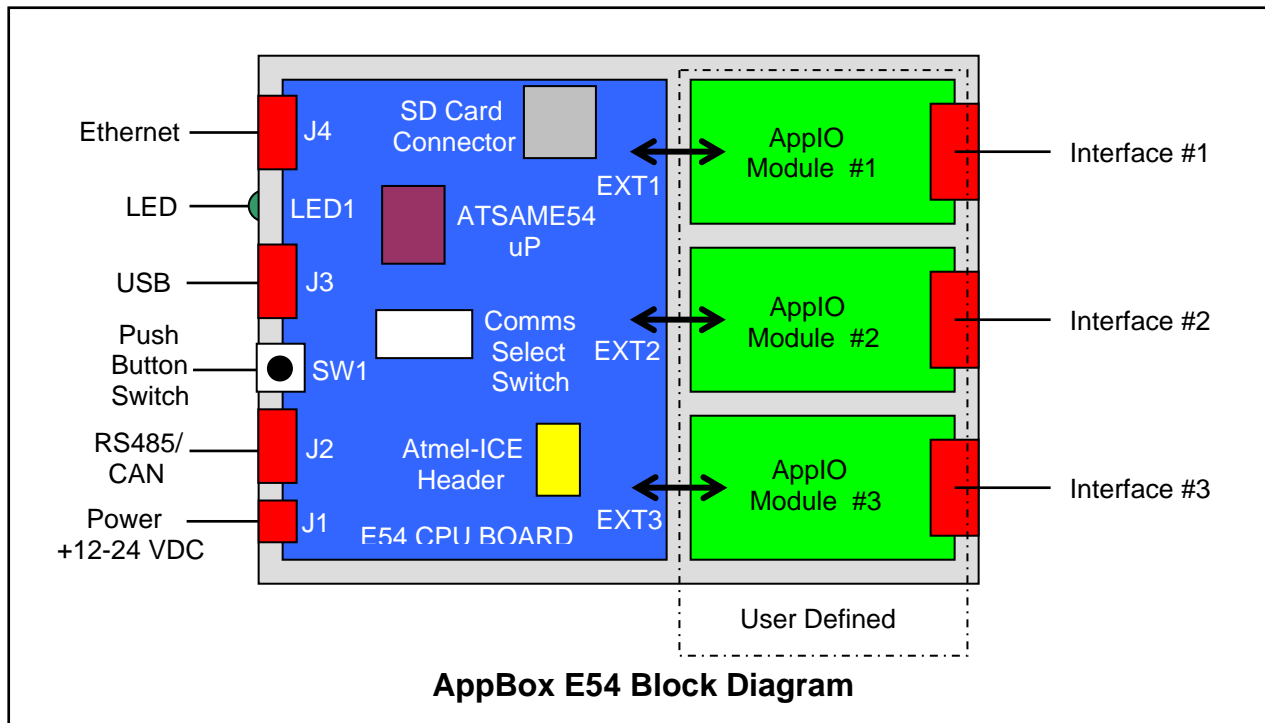

1.2 What's Included In the AppBox E54

The Spectrum Digital AppBox E54 product (Part/SKU #: 703919-0001) includes:

- AppBox E54 in anti-static bag
- Terminal block header for power input
- Product information card

NOTE: This product does not include any software or drivers. Development tools (Atmel-ICE and Software code generation suite) can be obtained from Microchip/Atmel at:

<https://www.microchip.com/development-tools/>.

1.3 AppBox E54 Front Panel

The features of the front panel on the AppBox E54 are shown in the figure below:

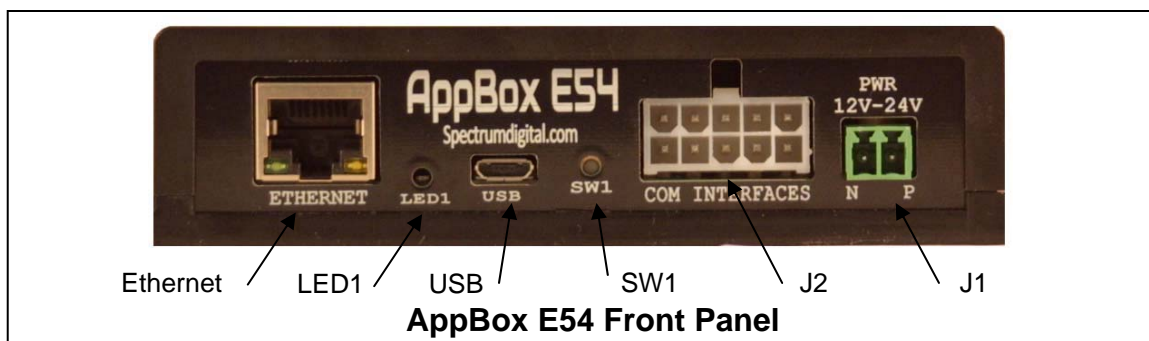

1.4 AppBox E54 Accessories

The following accessories for the AppBox E54 can be ordered from Spectrum Digital or authorized resellers:

Accessory Description	Part/SKU Number
AppBox Power Supply with cable, 110/220 VAC to 12 VDC, 1.5A	703925-0001
Distribution Box	703924-0001
AppBox cable	703925-0001
CAN cable	703912-0001
RS485 cable	703917-0001
USB - RS485 cable	703914-0001

1.5 AppBox E54 Communication Expansion

The J2 connector on the AppBox E54 presents multiple communication interfaces. The standard factory cables only support one interface at a time. To have access to multiple communication interfaces a Distribution Box (Part/SKU #: 703924-0001) and AppBox cable (Part/SKU #:703923-0001) are required. The Distribution Box expands the J2 connector to four (4) images of the AppBox E54 J2 connector. The AppBox cable bridges **all** signals on the AppBox E54 J2 connector to a connector on the Distribution Box. Be **aware** that **one** of the Distribution Box connectors will be used for the AppBox bridging cable leaving 3 connectors to be used for communication interfaces. All cables that can plug into the J2 connector on the AppBox E54 can plug into the Distribution Box.

The user should enable all interfaces they want to use with the Distribution Box by setting the switch positions on Switch SW2, positions 1 and 2. See section 3.3.

The AppBox E54 and Distribution Box system configuration is shown in the figure below:

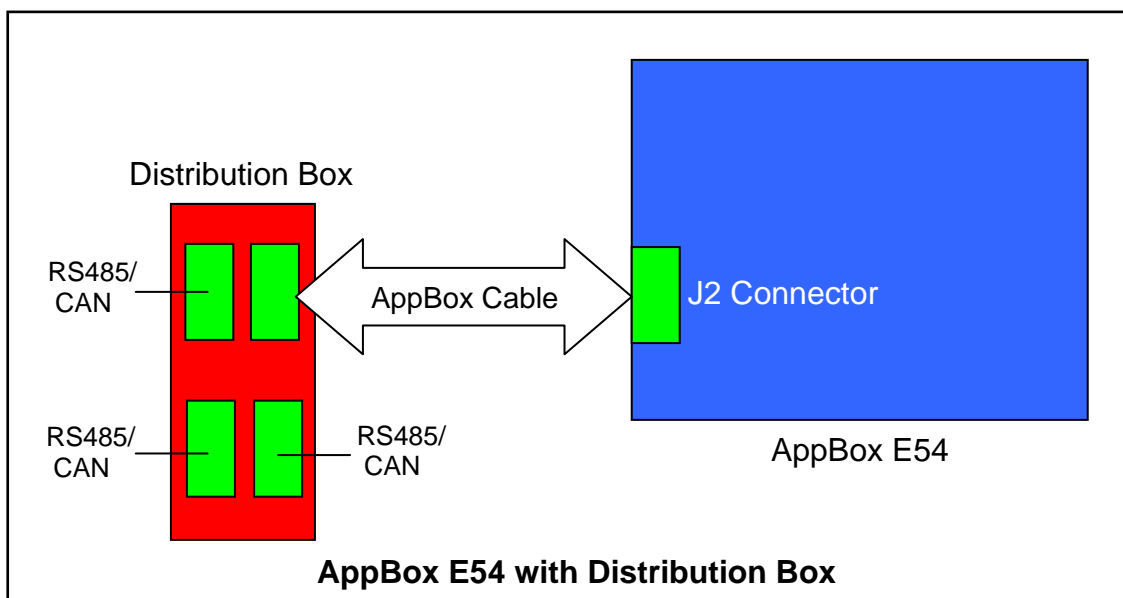

1.6 AppBox E54 Software Development Tools

The AppBox E54 is compatible with the software and hardware development tools from Microchip/Atmel. These tools are described on the Microchip/Atmel website:

<https://www.microchip.com/development-tools/>

These tools include the following:

- Editor
- Compiler/assembler/linker
- Libraries
- Operating System
- Debugger
- JTAG Emulator

2.0 Installation

2.1 Attaching Power to the AppBox E54

Power can be provided to the AppBox E54 by two different means; the AppBox power supply with cable (Part/SKU #: 703925-0001), or wiring the 2 position terminal block header (included with AppBox E54) that plugs into the E54 CPU Board's power input connector. See the figure below.

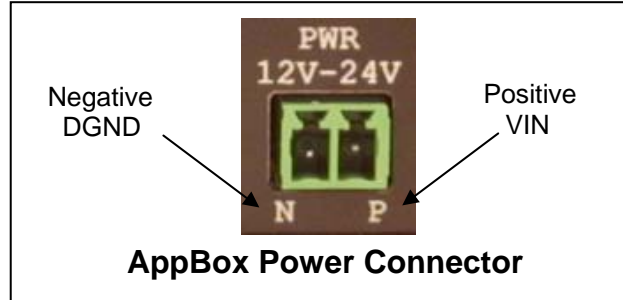

Listed below are the steps to install the terminal block header power connector into the AppBox E54.

1. Cut 2 pieces of wire (preferably 1 red for positive-VIN, 1 black for negative-DGND) to the desired length for your application. This wire should be 22 gauge or heavier
2. Strip ¼ inch (6-7 mm) of insulation from one end of each wire.
3. Position the terminal block header on a flat surface with the key stubs up and away from you. See the figure below.



4. Insert the negative/DGND wire (black) into the left wire hole and tighten the screw.
5. Insert the positive/VIN wire (red or black with strip) into the right wire hole and tighten the screw.
6. The terminal header should look like the figure below.

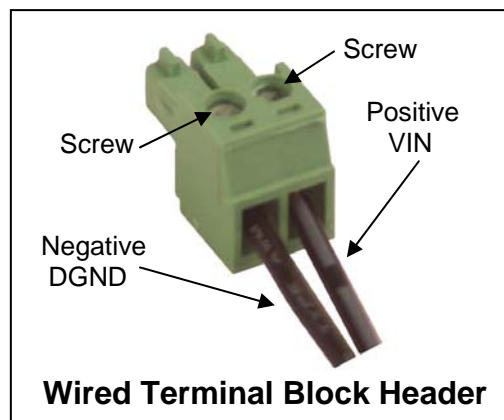

7. Pull/tug on the wires to insure they are secure in the terminal block.

8. Attach the loose end of the wires to a +12 – 24 VDC power source. Be sure of the polarity. This power source should supply at least 1 amp of current. This requirement will vary depending on the current requirements of the E54 CPU board and the AppIO Modules.
9. Turn on the power source.
10. With a multi-meter or oscilloscope measure the voltage at the terminal block header to verify +12 -24 VDC is present. Place the meter/scope probes on the 2 screws to measure.
11. Turn off the power source
12. Insert the terminal block header into the power input of the AppBox E54.
13. Turn on the power source.

2.2 Installation of AppIO Modules

Listed below are the steps to install AppIO Modules in the AppBox E54:

1. Remove **ALL** power to the AppBox enclosure
2. Remove all interface connections attached to the installed AppIO Modules
3. Remove the CAN/RS-485/USB/Ethernet connections to the E54 processor board
4. Turn the AppBox over and remove the 2 screws from the bottom of the enclosure as shown below

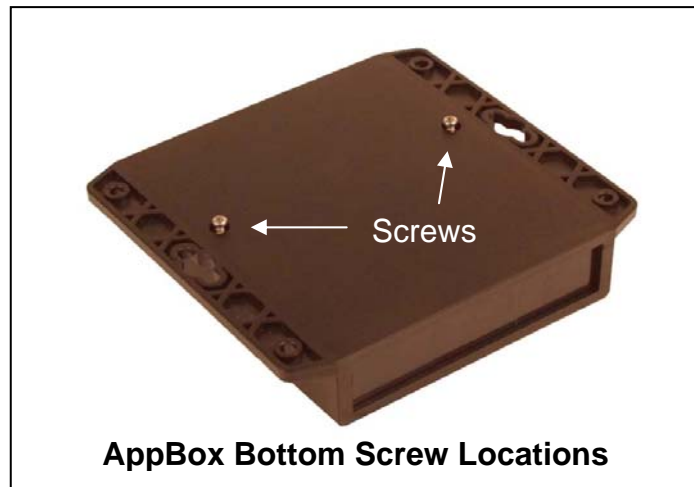

5. Turn the AppBox back over (label showing) and lift the top off the enclosure being careful not to lose the knockout panels
6. If necessary remove one or more existing AppIO Modules and associated knockout panels by unscrewing the 2 screws
7. Plug the new AppIO Module(s) into EXT1, EXT2, or EXT3 on the E54 CPU Board

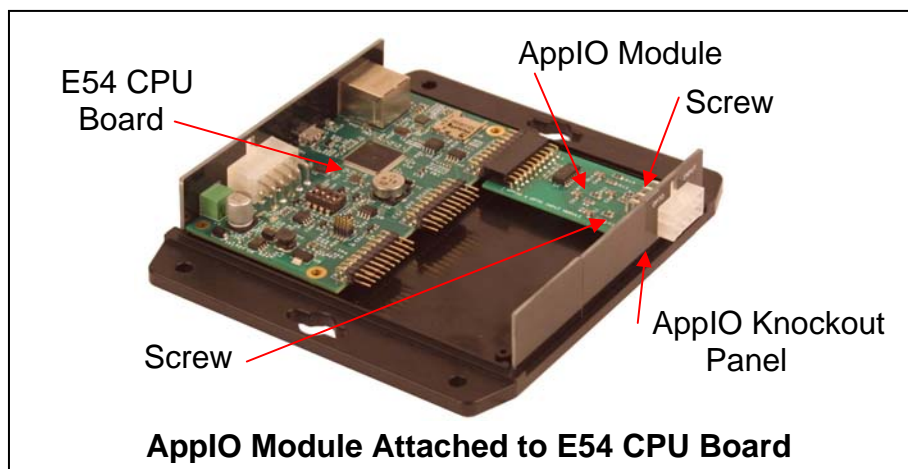

8. Insert the included knock out panel associated with this AppIO Module
9. Insert and tighten the 2 screws for the AppIO Module
10. Insert the knock out panels in any unused positions
11. Place the cover back over the E54 processor board and AppIO Modules
12. Insert the 2 screws back in and tighten until snug, do not over tighten/strip the screws

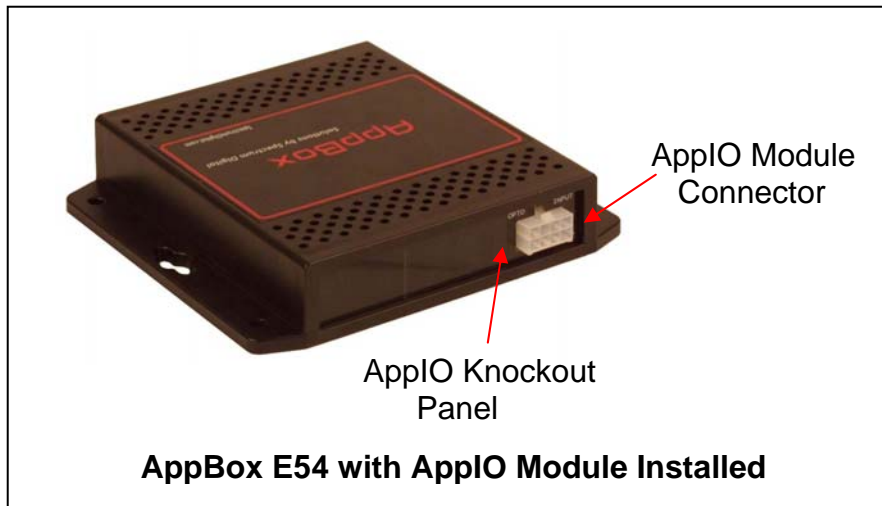

13. Re-attach the CAN/RS-485/USB/Ethernet connections to the processor board
14. Re-attach all interface connections to the AppIO Modules
15. Apply power to the AppBox E54

2.3 Attachment of Distribution Box to the AppBox E54

Listed below are the steps to attach the Distribution Box (Part/SKU #: 703924-0001) to the AppBox E54:

1. Remove **ALL** power to the AppBox E54 enclosure
2. Remove any communication cables from the J2 connector on the AppBox E54
3. Plug one end of the AppBox cable (Part/SKU #: 703923-0001) into the J2 connector on the AppBox E54
4. Plug the other end of the AppBox cable into one of the connectors on the Distribution Box

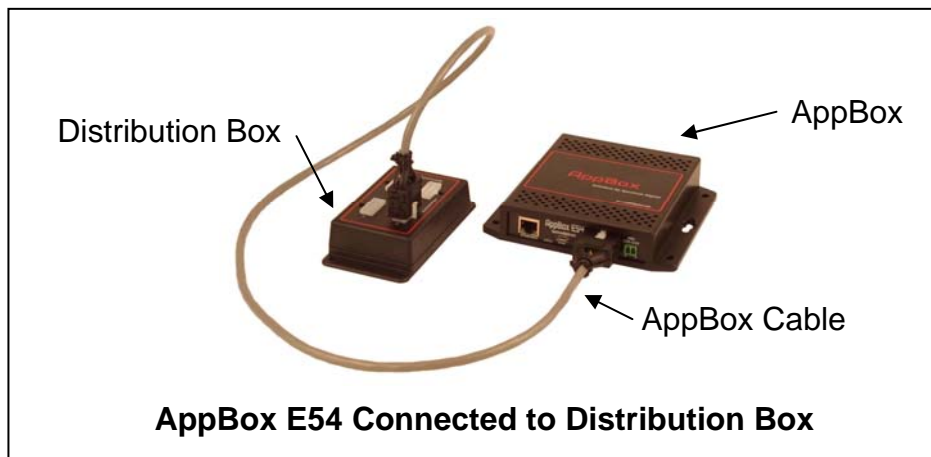

5. Plug the desired communication cables into the Distribution Box
6. Make all other connections before powering
7. Apply power to the AppBox E54

2.4 Installation of Atmel-ICE emulator

Listed below are the steps to install Atmel-ICE emulator:

1. Remove **ALL** power to the AppBox E54 enclosure
2. Remove all interface connections attached to the AppIO Modules
3. Remove the CAN/RS-485/USB/Ethernet connections to the processor Module
4. Turn the AppBox over and remove the 2 screws from the bottom of the enclosure as shown below

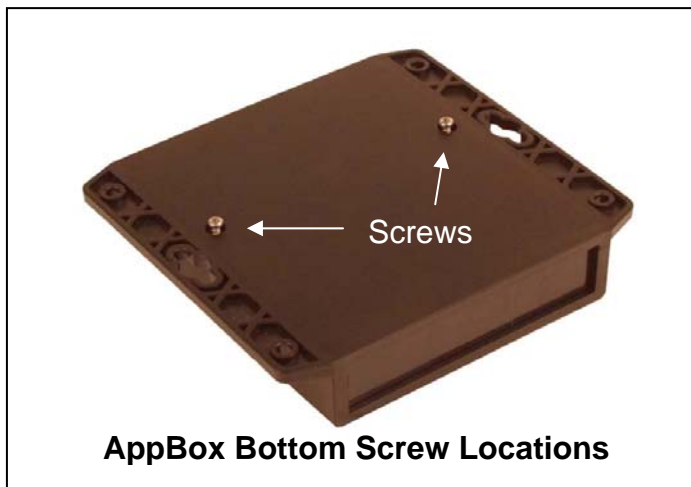

5. Turn the AppBox back over (label showing) and lift the top off the enclosure being careful not to lose the knockout panels
6. Plug the emulator end of the ribbon cable into the "SAM" Port on the emulator
7. Plug in the Atmel-ICE debug into connector J6 on the AppBox E54 CPU board. Visually inspect the connection to insure all the board pins are in the female cable connector.

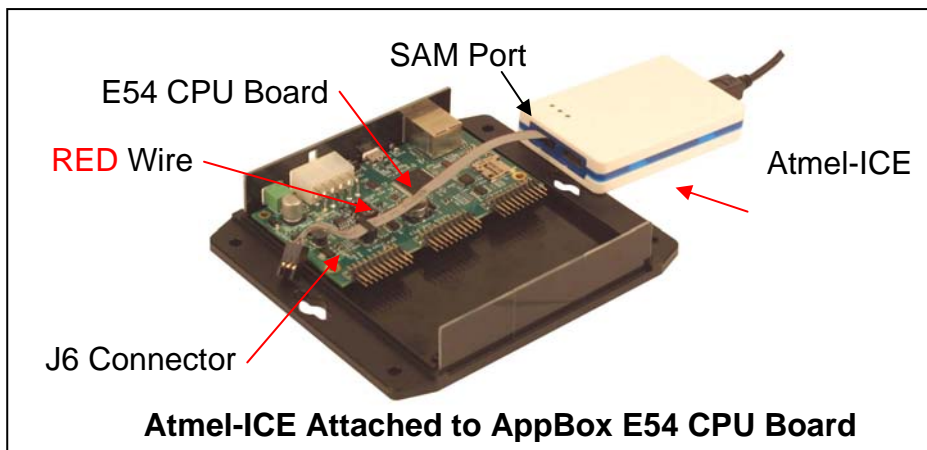

8. Re-attach the CAN/RS-485/USB/Ethernet connections to the processor board
9. Re-attach all interface connections to the AppIO Modules
10. Apply power to the AppBox E54
11. Start debug session on the host computer

3.0 Interfaces

This section describes the interfaces on the AppBox E54 CPU Board. These interfaces include the connectors, jumpers, switches, LEDs, and test points.

The location of each of these interfaces is shown in the figure below:

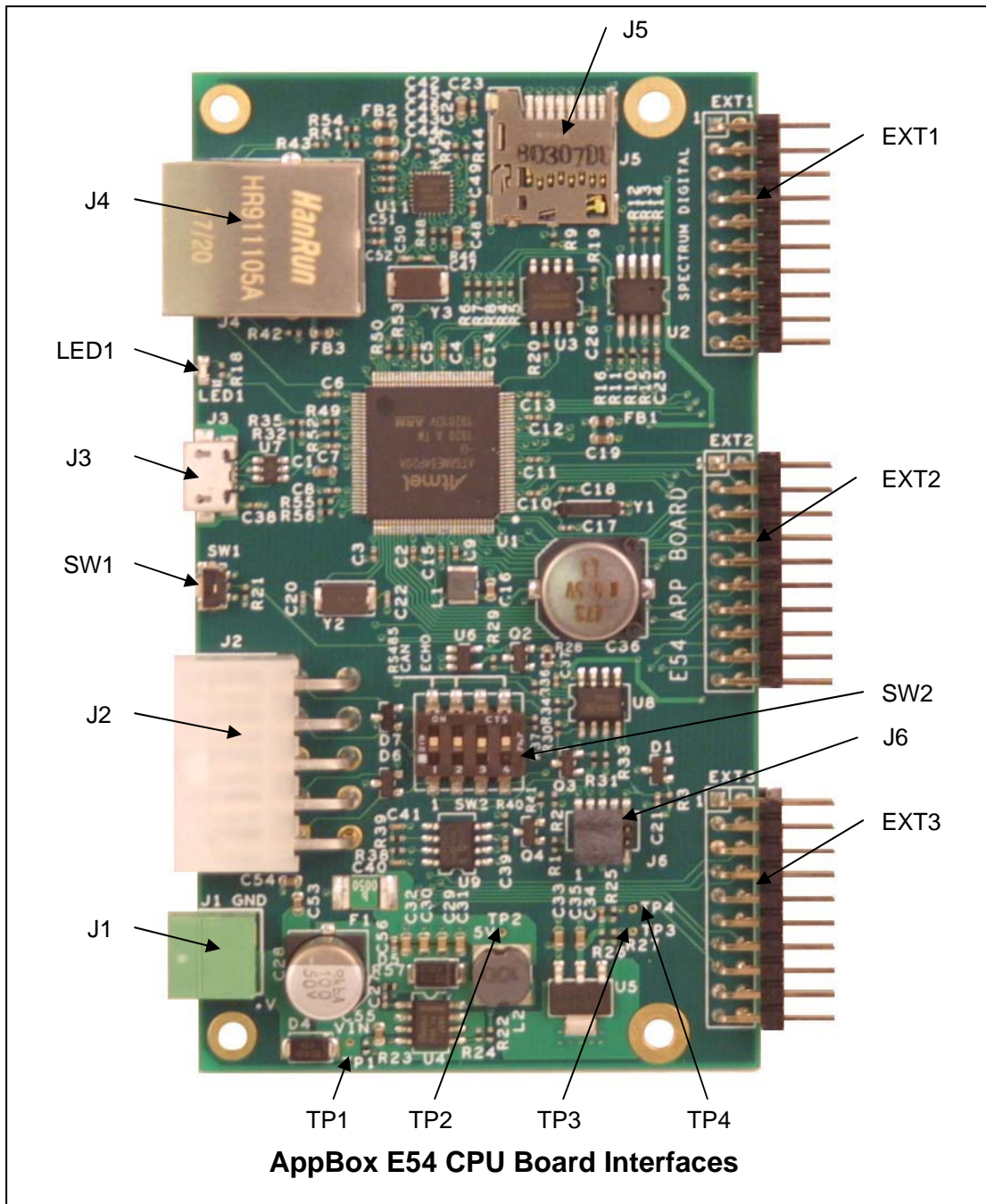

The table below lists all the interfaces on the AppBox E54 CPU Board.

AppBox E54 CPU BOARD INTERFACES	
INTERFACE NAME	TYPE OF INTERFACE
J1	Connector for power input
J2	Connector for RS-485/CAN
J3	USB Connector
J4	Ethernet Connector
J5	SD Card Connector
J6	Connector for header 5x2 Cortex-M Debug
EXT1	Connector to AppIO Module
EXT2	Connector to AppIO Module
EXT3	Connector to AppIO Module
JP1	SMT jumper (bottom)
JP2	SMT jumper (bottom)
JP3	SMT jumper (bottom)
JP4	SMT jumper (bottom)
JP5	SMT jumper (bottom)
JP6	SMT jumper (bottom)
JP7	SMT jumper (bottom)
JP8	SMT jumper (bottom)
SW1	Pushbutton switch
SW2	4 position DIP switch
LED1	Green LED
TP1	Test point
TP2	Test point
TP3	Test point
TP4	Test Point

3.1 Connectors

The following section describes the connectors on the AppBox E54 CPU Board.

INTERFACE NAME	TYPE OF INTERFACE	MATING CONNECTOR
J1	Connector for power input, 2 position	Amphenol Anytek Terminal Block Plug, 2 pos TJ0231530000G TS02315A0000G
J2	Connector for RS-485/CAN, 10 position, 2 x 5	Molex 10 Position Rectangular Housing Connector Receptacle Natural 0.165" (4.20mm) 0039012100, 0039000038
J3	USB Connector	USB micro
J4	Ethernet Connector	RJ-45
J5	SD Card Connector	Micro SD card
J6	Connector for header 5x2 Cortex-M Debug	Cortex-M Debug tail
EXT1	Connector to AppIO Module #1, 20 position, 2 x 10	
EXT2	Connector to AppIO Module #2, 20 position, 2 x 10	
EXT3	Connector to AppIO Module #3, 20 position, 2 x 10	

3.1.1 J1, Power Connector

This section describes J1, the power connector. Shown below is a physical diagram of the J1 connector.

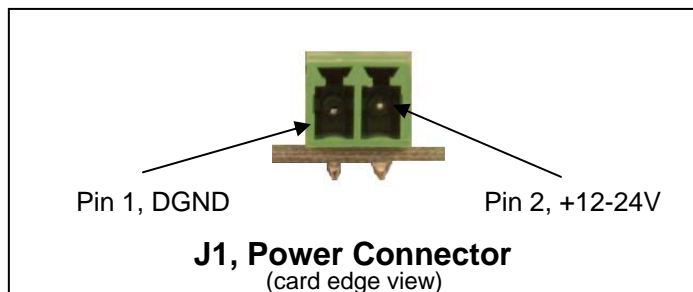

The following table shows the signals present on the J1 connector.

J1, Power Connector	
Pin number	Signal name
1	DGND
2	VIN, (+12-24 VDC)

3.1.2 J2, RS485 / CAN Connector

This section describes J2, the RS485/CAN connector. The diagram below shows the physical diagram of the J2 connector.

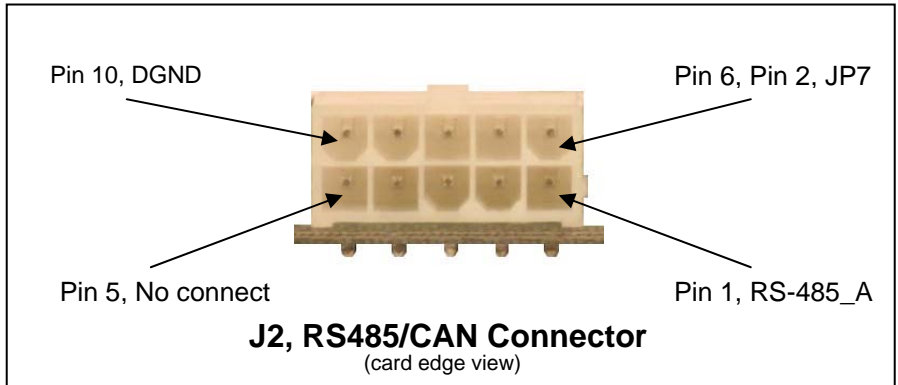

The following table shows the signals present on the J2 connector.

J2, RS485 / CAN Connector	
Pin number	Signal name
1	RS485_A
2	RS485_B
3	DGND
4	CAN_H
5	CAN_L
6	JP8, VDD_5V if installed
7	DGND
8	No Connect
9	No Connect
10	DGND

3.1.3 J3, USB Connector

The following table shows the signals present on the J3 connector. The J3 connector is female mini USB connector.

J3, USB Connector	
Pin number	Connector Signal Name – Attach Signal Name
1	VBUS to Pin 5, U7
2	D- to USB_DM, Pin 1, U7, PA24_USB_DM
3	D_ to USB_DP, Pin 3, U7, PA25_USB_DP
4	ID to IO3, Pin 4, U7, PC19_USB_ID
5	GND to DGND, Pin 2, U7
6	Shield1, DGND via a capacitor
7	Shield2, DGND via a capacitor
8	Shield3, DGND via a capacitor
9	Shield4, DGND via a capacitor
10	Shield5, DGND via a capacitor
11	Shield6, DGND via a capacitor

3.1.4 J4, Ethernet Connector

The following table shows the signals present on the J4 connector.

J4, Ethernet Connector	
Pin number	Connector Signal Name – Attach Signal Name
1	TD+ to Pin 6, U11
2	TD- to Pin 5, U11
3	RD+ to Pin 4, U11
4	TCT to DGND via cap
5	RCT to DGND via cap
6	RD- to Pin 3, U11
7	No connect
8	CHS GND to Ground
9	GRN_A to VDD_3V3
10	GRN_C to LED0/ANEN_SPEED
11	YEL_C to PC15_ETH_LED
12	YEL_A to VDD_3V3
13	SH1 to Ground
14	SH2 to Ground
15	MH1, No connect
16	MH2, No connect

3.1.5 J5, SD Card Connector

The J5 SD card connector supports a micro SD memory card with a memory size up to xx GB. The following table shows the signals present on the J5 connector.

J5, SD Card Connector	
Pin number	Connector Signal Name – uP Signal Name
1	DAT2 to PB20_MCDA2
2	DAT3 to PB21_MCDA3
3	CMD to PA20_MCCDA
4	VDD to VDD_3V3
5	CLK to PA21_MCCK
6	VSS to DGND
7	DAT0 to PA18_MCDA0
8	DAT2 to PB19_MCDA1
9	COM to DGND
10	CD to PD20_MC_DETECT
11	PAD1 to DGND
12	PAD2 to DGND
12	PAD3 to DGND
14	PAD4 to DGND

3.1.6 J6, Cortex-M Debug Connector

The following table show the signals present on the J6 connector.

J6, Cortex-M Debug Connector	
Pin number	Signal name
1	VDD_3V3, +3.3 volts
2	PA31_SWDIO
3	DGND
4	PA30_SWCLK
5	DGND
6	PB30_SWO
7	No Connect
8	No Connect
9	DGND
10	RESETn

3.1.7 AppIO Module Connectors

The E54 APP Board has 3 connectors which allow the AppBox E54 to be customized to meet specific application requirements. By using function specific AppIO Modules the user can tailor their system configuration to meet their unique requirements. The AppIO Modules can be plugged into any of the 3 connectors (EXT1, EXT2, EXT3). These 3 connectors are 20 pin, 2 x 10 double row, right angle connectors with pins on 0.1 inch (2.54 mm) centers.

Note: The user should be aware that several signals from the AppBox E54 CPU are shared and present on all 3 connectors. If the signals are used by one connector (AppIO Module) they should not be used on the other connectors.

The following diagram shows the physical layout of the EXT1, EXT2, and EXT3 connectors.

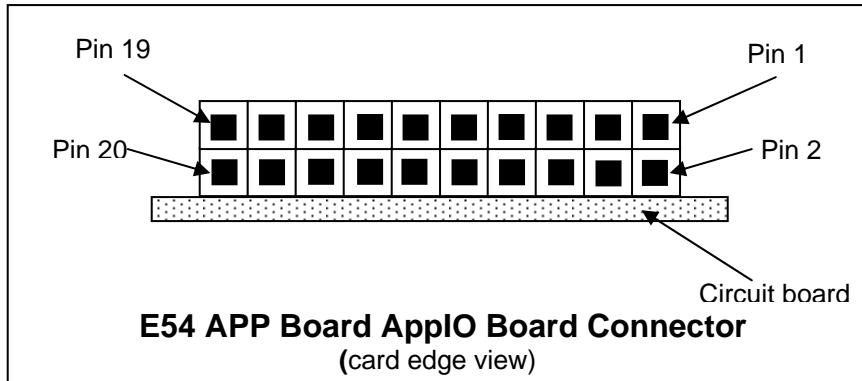

3.1.7.1 EXT1, AppIO Module Connector

The following table shows the signals present on the EXT1 connector.

EXT1, AppIO Module Connector			
Pin #	Signal Name	Function	Shared Functionality
1	Pin 2, JP1	+5 volts to AppIO Module if shorted	VDD_5V
2	DGND	Ground	Ground
3	PB04_ADC(P)	A/D converter, alternatively positive part of differential ADC	
4	PB05_ADC(N)	A/D converter, alternatively negative part of differential ADC	
5	PA06_GPIO	General purpose I/O	
6	PA07_GPIO	General purpose I/O	
7	PB08_PWM(P)	PWM, alternatively positive part of differential PWM	
8	PB09_PWM(N)	PWM, alternatively negative part of differential PWM	
9	PB07_IRQ/GPIO	Interrupt request line and/or GPIO	
10	PA27_SPI_SS_B/GPIO	Slave select for SPI and/or GPIO	
11	PA22_TWI_SDA	Data line for I ² C interface, always implemented, bus type	
12	PA23_TWI_SCL	Clock line for I ² C interface, always implemented, bus type	
13	PA05_UART_RX	Receiver line of target device UART	
14	PA04_UART_TX	Transmitter line of target device UART	
15	PB28_SPI_SS_A	Slave select for SPI	
16	PD27_SPI_MOSI	Master out slave out line of serial peripheral interface, always implemented, bus type	
17	PD29_SPI_MISO	Master in slave out line of serial peripheral interface, always implemented, bus type	
18	PD26_SPI_SCK	Clock for serial peripheral interface, always implemented, bus type	
19	DGND	Ground	Ground
20	VDD_3V3	Power for the AppIO Module	Power for the AppIO Module

3.1.7.2 EXT2, AppIO Module Connector

The following table shows the signals present on the EXT2 connector.

EXT2, AppIO Module Connector			
Pin #	Signal Name	Function	Shared Functionality
1	Pin 2, JP2	+5 volts to AppIO Module if shorted	VDD_5V
2	DGND	Ground	Ground
3	PB00_ADC(P)	A/D converter, alternatively positive part of differential ADC	
4	PA03_ADC(N)	A/D converter, alternatively negative part of differential ADC	
5	PB01_GPIO	General purpose I/O	
6	PB15_GPIO	General purpose I/O	
7	PB14_PWM(P)	PWM, alternatively positive part of differential PWM	
8	PB15_PWM(N)	PWM, alternatively negative part of differential PWM	
9	PD00_IRQ_GPIO	Interrupt request line and/or GPIO	
10	PB02_SPI_SS_B/GPIO	Slave select for SPI and/or GPIO	
11	PD08_TWI_SDA	Data line for I ² C interface, always implemented, bus type	
12	PD09_TWI_SCL	Clock line for I ² C interface, always implemented, bus type	
13	PAB17_UART_RX	Receiver line of target device UART	
14	PB16_UART_TX	Transmitter line of target device UART	
15	PC06_SPI_SS_A	Slave select for SPI	
16	PC04_SPI_MOSI	Master out slave out line of serial peripheral interface, always implemented, bus type	
17	PC07_SPI_MISO	Master in slave out line of serial peripheral interface, always implemented, bus type	
18	PC05_SPI_SCK	Clock for serial peripheral interface, always implemented, bus type	
19	DGND	Ground	Ground
20	VDD_3V3	Power for the AppIO Module	Power for the AppIO Module

3.1.7.3 EXT3, AppIO Module Connector

The following table shows the signals present on the EXT3 connector.

EXT3, AppIO Module Connector			
Pin #	Signal Name	Function	Shared Functionality
1	Pin 2, JP3	+5 volts to AppIO Module if shorted	VDD_5V
2	DGND	Ground	Ground
3	PC02_ADC(P)	A/D converter, alternatively positive part of differential ADC	
4	PC03_ADC(N)	A/D converter, alternatively negative part of differential ADC	
5	PC01_GPIO	General purpose I/O	LED1
6	PC10_GPIO	General purpose I/O, SW1	
7	PD10_PWM(P)	PWM, alternatively positive part of differential PWM	
8	PD11_PWM(N)	PWM, alternatively negative part of differential PWM	
9	PC30_IRQ/GPIO	Interrupt request line and/or GPIO	
10	PC31_SPI_SS_B/GPIO	Slave select for SPI and/or GPIO	
11	PD08_TWI_SDA	Data line for I ² C interface, always implemented, bus type	Pin 11, EXT2, Pin 5, U2
12	PD09_TWI_SCL	Clock line for I ² C interface, always implemented, bus type	Pin 12, EXT2, Pin 6, U2
13	PC23_UART_RX	Receiver line of target device UART	
14	PC22_UART_TX	Transmitter line of target device UART	
15	PC14_SPI_SS_A	Slave select for SPI	
16	PC04_SPI_MOSI	Master out slave out line of serial peripheral interface, always implemented, bus type	Pin 16, EXT2
17	PC07_SPI_MISO	Master in slave out line of serial peripheral interface, always implemented, bus type	Pin 17, EXT2
18	PC05_SPI_SCK	Clock for serial peripheral interface, always implemented, bus type	Pin 18, EXT2
19	DGND	Ground	Ground
20	VDD_3V3	Power for the AppIO Module	Power for the AppIO Module

3.2 Jumpers

This section describes the jumpers on the AppBox E54 CPU Board . All jumpers are located on the bottom side of the circuit board. All jumpers are surface mount jumpers. The figure below shows the location of each jumper.

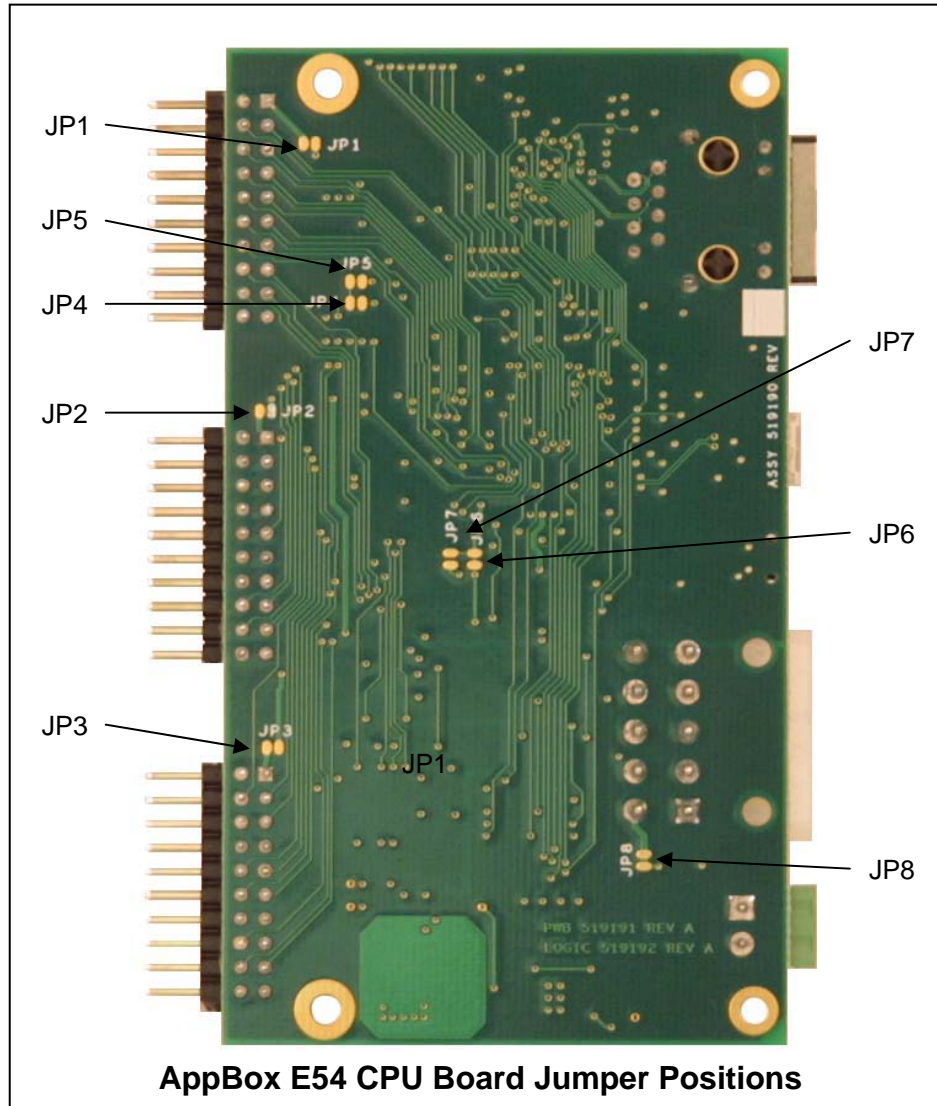

The table below describes the jumpers on the AppBox E54 CPU Board.

JUMPER NAME	POSITION DESCRIPTION	FACTORY DEFAULT POSITION
JP1	Installed = +5 V power to Pin 1, EXT1	Installed
JP2	Installed = +5 V power to Pin 1, EXT2	Installed
JP3	Installed = +5 V power to Pin 1, EXT3	Installed
JP4	Installed = PC28_WP to Pin 7, U2, WP	Open – see warning1
JP5	Installed = DGND to Pin 7, U2, WP	Installed – see warning 1
JP6	Installed – VBAT to PB03_VBAT	Installed – see warning 2
JP7	Installed = VDD_3V3 to PB03_VBAT	Open – see warning 2
JP8	Installed = +5 V power to Pin 1, J2	Open



WARNING 1 !

Jumpers JP4 and JP5 are used in the same circuit. Only 1 should be installed. If both are installed the circuit could be damaged.



WARNING 2 !

Jumpers JP6 and JP7 are used in the same circuit. Only 1 should be installed. If both are installed the circuit could be damaged.

3.3 Switches

The table below describes the switches on the AppBox E54 CPU board.

SWITCH NAME	TYPE OF SWITCH	FUNCTION	FACTORY DEFAULT POSITION
SW1	Pushbutton switch	P31_SWITCH	Open
SW2, position 1, on	Rocker switch	Connects RS485A to RS485B RS485 terminator on	X
SW2, position 1, off	Rocker switch	Disconnects RS485A from RS485B RS485 terminator off	
SW2, position 2, on	Rocker switch	Connects CAN_H to CAN_L CAN termination on	X
SW2, position 2, off	Rocker switch	Disconnects CAN_H from CAN_L CAN termination off	
SW2, position 3	Rocker switch	Not used	
SW2, position 4, on	Rocker switch	Connects PC26_RS485_TXEN to RS485_ECHO, RS485 echo	
SW2, position 4, off		Disconnects PC26_RS485_TXEN from RS485_ECHO, No RS485 echo	X

The figure below shows the switch, SW2, in the “Factory Default Position”. Switch positions 1 and 2 are in the “ON” position (slide moved to the right). Switch positions 3 and 4 are in the “OFF” position (slide moved to the left). Position 3 is not used on the E54 APP Board.

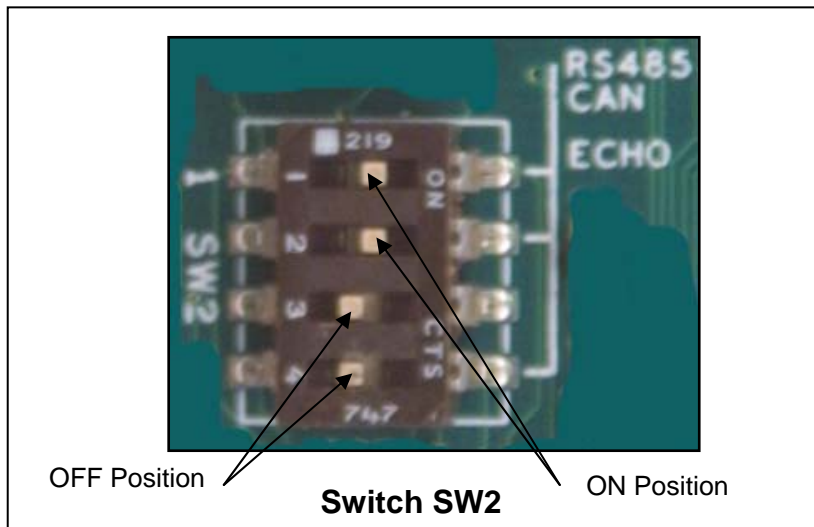

3.4 LEDs

The table below describes the LED on the AppBox E54 CPU Board.

LED NAME	COLOR	MEANING
LED1	Green	User control, PC18_GREEN_LED

3.5 Test Points

This section discusses the test points on the AppBox E54 CPU Board. All test points are on the top side of the circuit board. Their location is shown in the diagram in section 3.0. The table below describes the test points on the E54 CPU board.

TEST POINT NAME	SIGNAL PRESENT
TP1	Input DC voltage, (+12-24 vdc)
TP2	VDD_5V, +5 volts
TP3	DGND
TP4	VDD_3V3

4.0 Physical Characteristics

The physical characteristics of the AppBox E54 are described below:

Enclosure (with flanges): 5.83 in(148.26 mm) x 5.13 in(130.5 mm) x 1.10 in(27.94 mm)

E54 CPU Board (without connectors): L: 4.15 in(105 mm) x W: 2.36 in (60 mm)

E54 CPU Board (width with connectors): W: 2.77 (70.5 mm)

E54 CPU Board (maximum height): H: 0.67 in (17 mm)

Weight of enclosure with controller board: 6 ounces (.17 kg)

Operating Temperature: -0C to +70C

Storage Temperature: -40C to +85 C

Relative Humidity: 0 to 90% (non-condensing)

Maximum power consumption of controller board: 1 amp at +12 volts

RoHS Compliant: Yes

5.0 Mechanical Information

The following drawing provides the mechanical information for the AppBox E54. All dimensions are in inches.

Note: Drawing is **NOT** to scale.

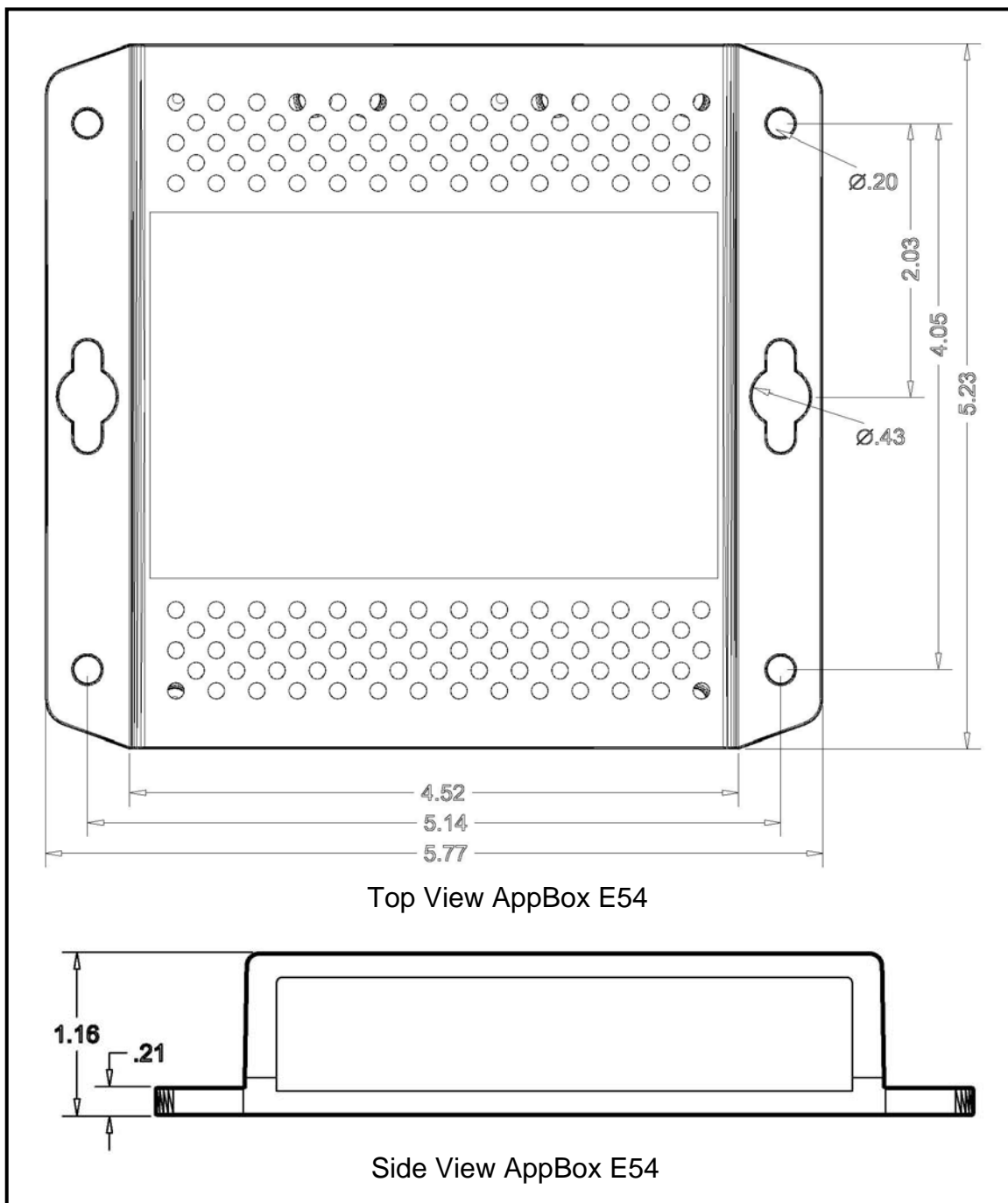

6.0 Schematics

The following pages include the schematics for the E54 APP Board inside the AppBox E54.

NOTES:

1. JUMPER/NO and JUMPER/NC on back of board

10	9	8	7	6
5	4	3	2	1

J2

Shared Pins	
PA22_TWI_SDA	EXT1, CAT24CS12
PA23_TWI_SCL	EXT1, CAT24CS12
PC04_SPL_MOSI	EXT2-3
PC05_SPL_SCK	EXT2-3
PC07_SPL_MISO	EXT2-3
PD07_TWI_SDA	EXT2-3
PD09_TWI_SCL	EXT2-3

SWITCH	Pos	Function
SW2-1	On	RS458 Termination
SW2-2	On	CAN Termination
SW2-3	-	-
SW2-4	Off	RS485 Echo

SPECTRUM DIGITAL INCORPORATED

Title: E54 APPLICATION BOARD

Page Contents: TITLE

Size: B DWG NO 519192 Revision: B

Date: Friday, March 13, 2020 Sheet 1 of 7

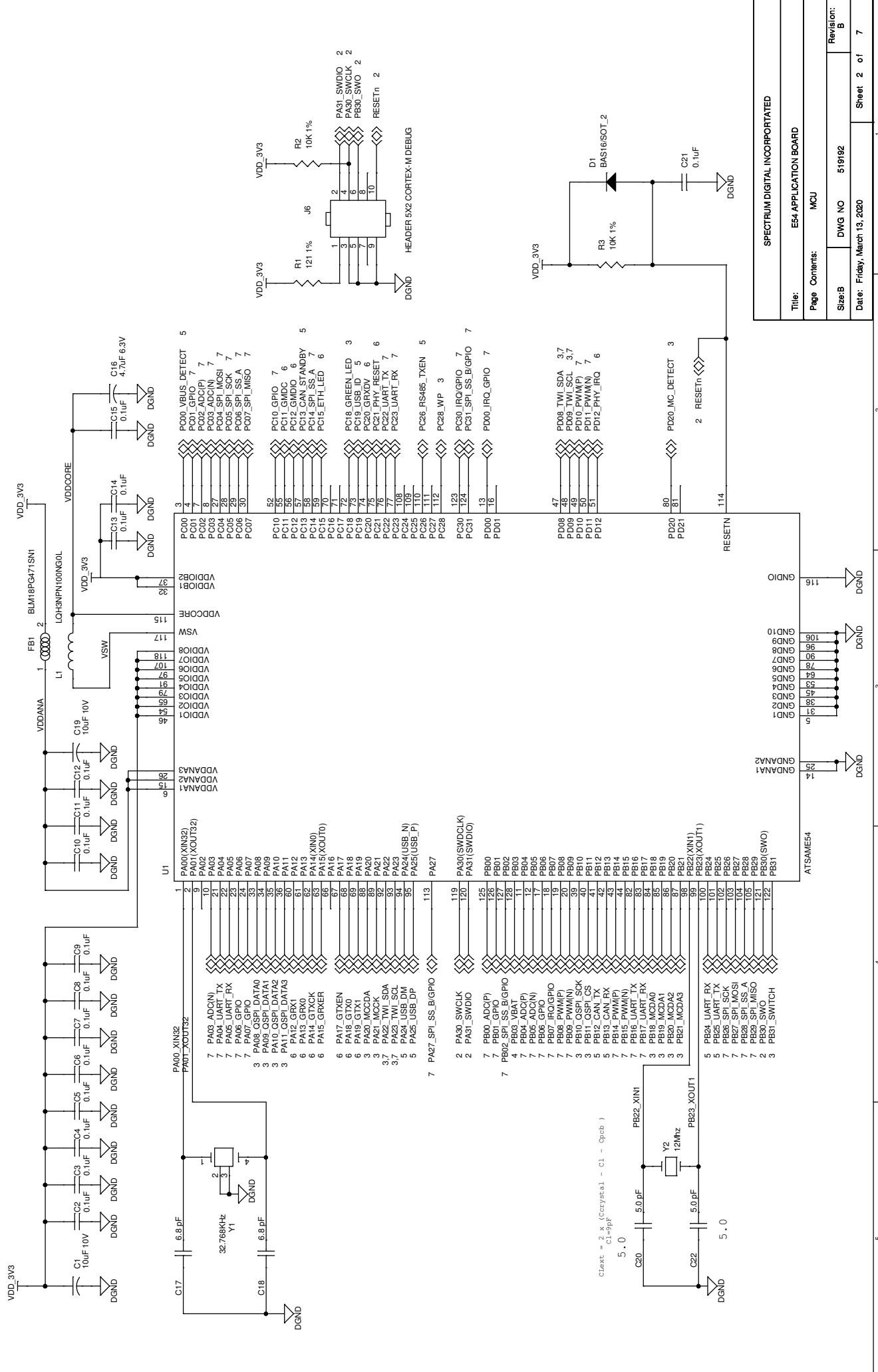

SPECTRUM DIGITAL INCORPORATED	
Title: E64 APPLICATION BOARD	
Page Contents: MCU	
Size: B	Revision: B
Date: Friday, March 13, 2020	DWG NO 519192
Sheet 2 of 7	

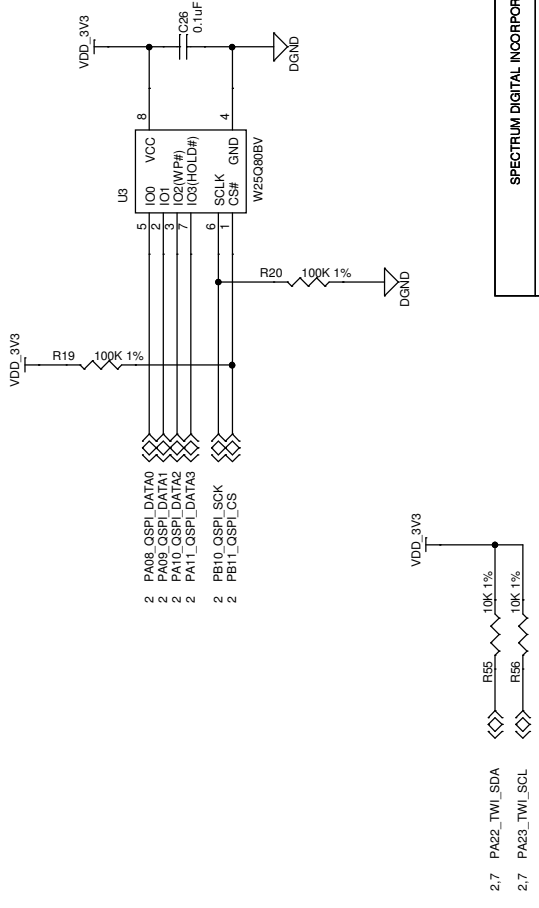
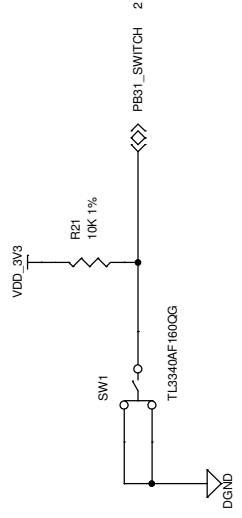
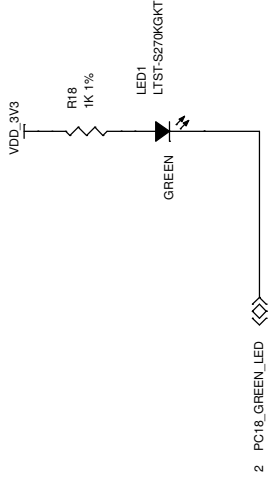
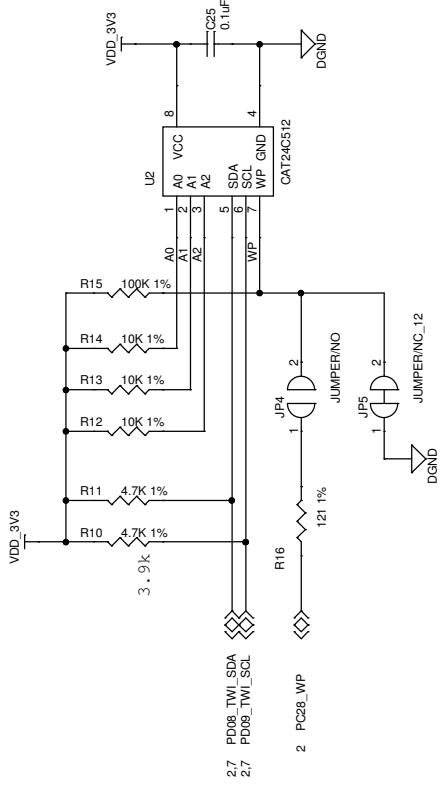
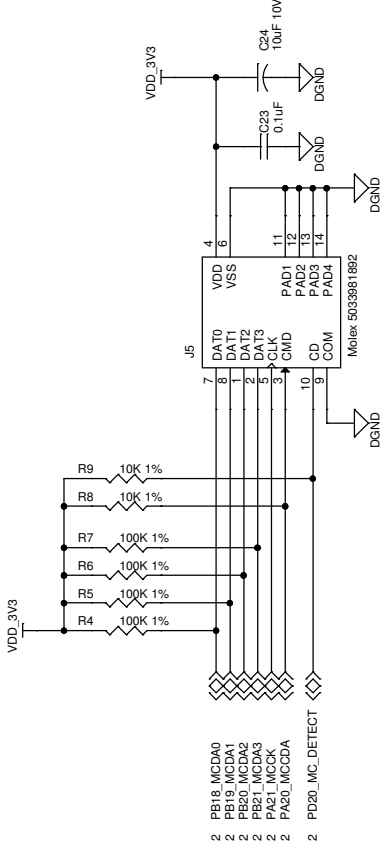

SPECTRUM DIGITAL INCORPORATED	
Title: E54 APPLICATION BOARD	
Page Contents: MEMORY	
Size: B	DWG NO 519192
Date: Friday, March 13, 2020	Revision: B
Sheet 3 of 7	

12V/24V AC/DC

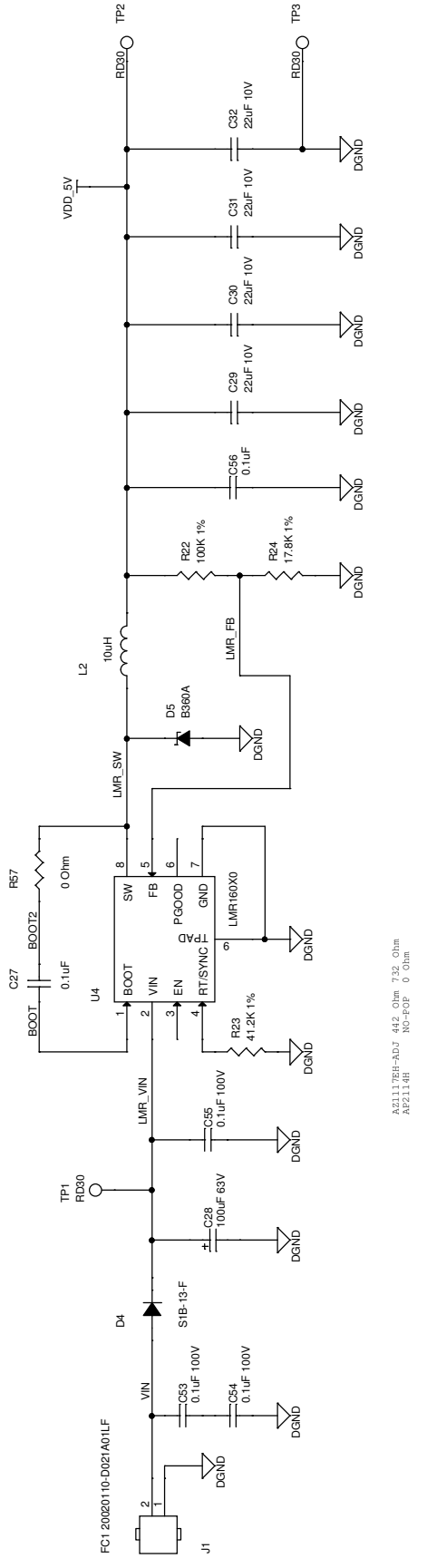

32111TEH-3DJ 442 Ohm 732 Ohm
AP2114H NO-POP 0 Ohm

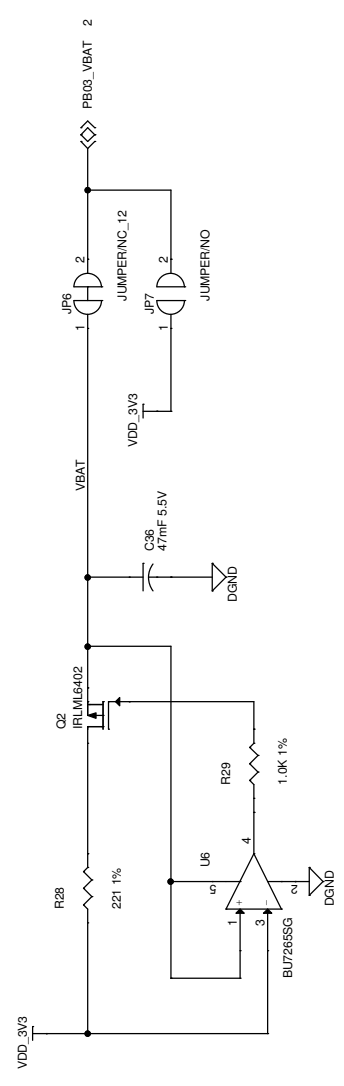
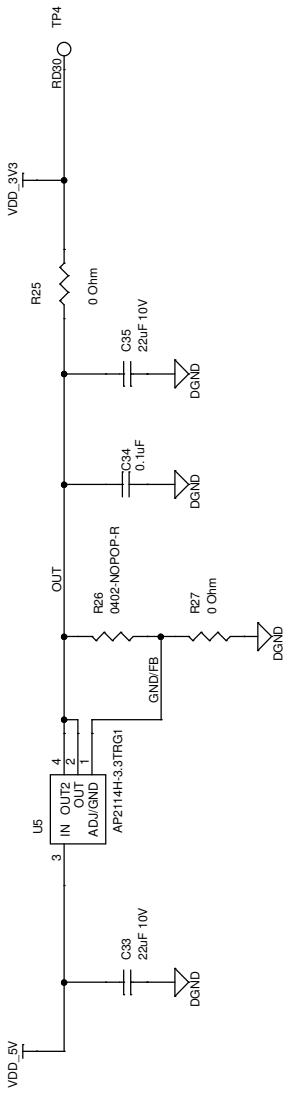

SPECTRUM DIGITAL INCORPORATED			
Title:		E70 APPLICATION BOARD	
Page Contents:		POWER	
Size:	B	DWG NO	519192
Date:	Friday, March 13, 2020	Revision:	B
Sheet:	4	of	7

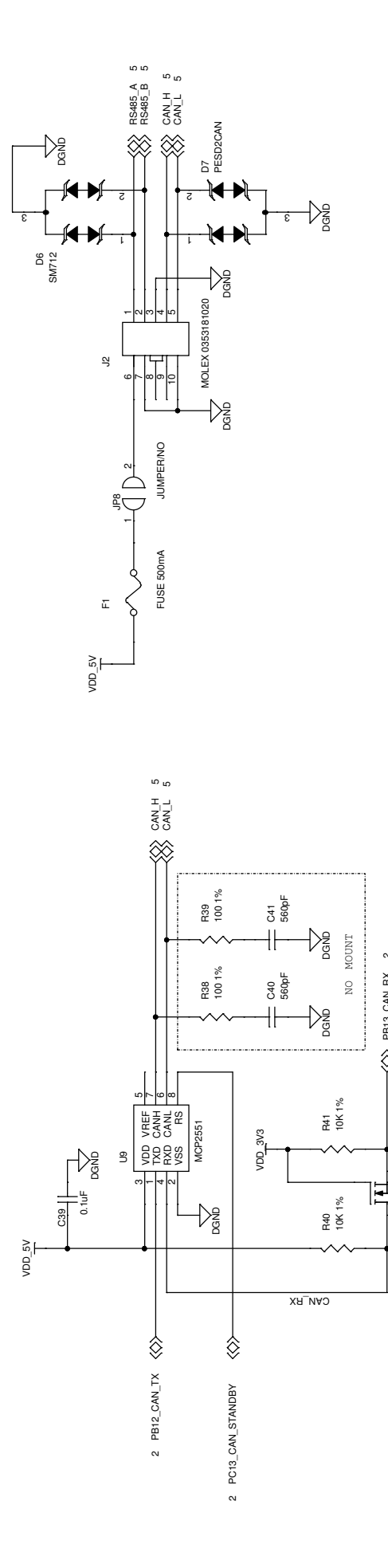
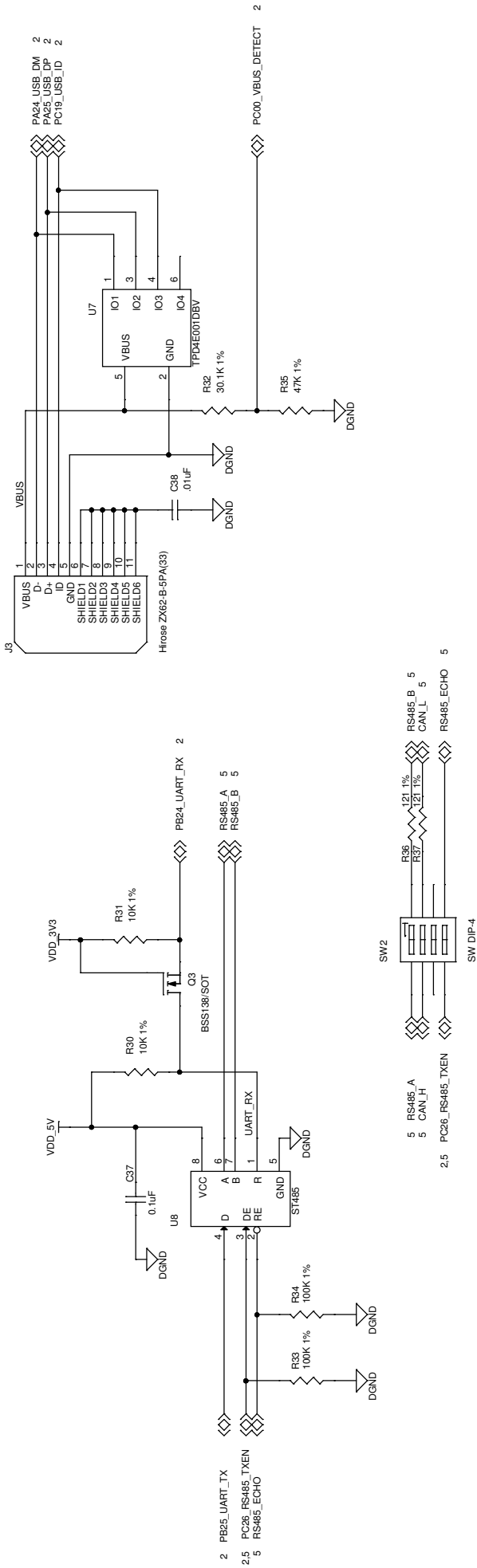

SPECTRUM DIGITAL INCORPORATED	
Title:	E54 APPLICATION BOARD
Page Contents:	COM
Size:	B
DWG NO	519192
Date:	Friday, March 13, 2020
Revision:	B
Sheet	5 of 7

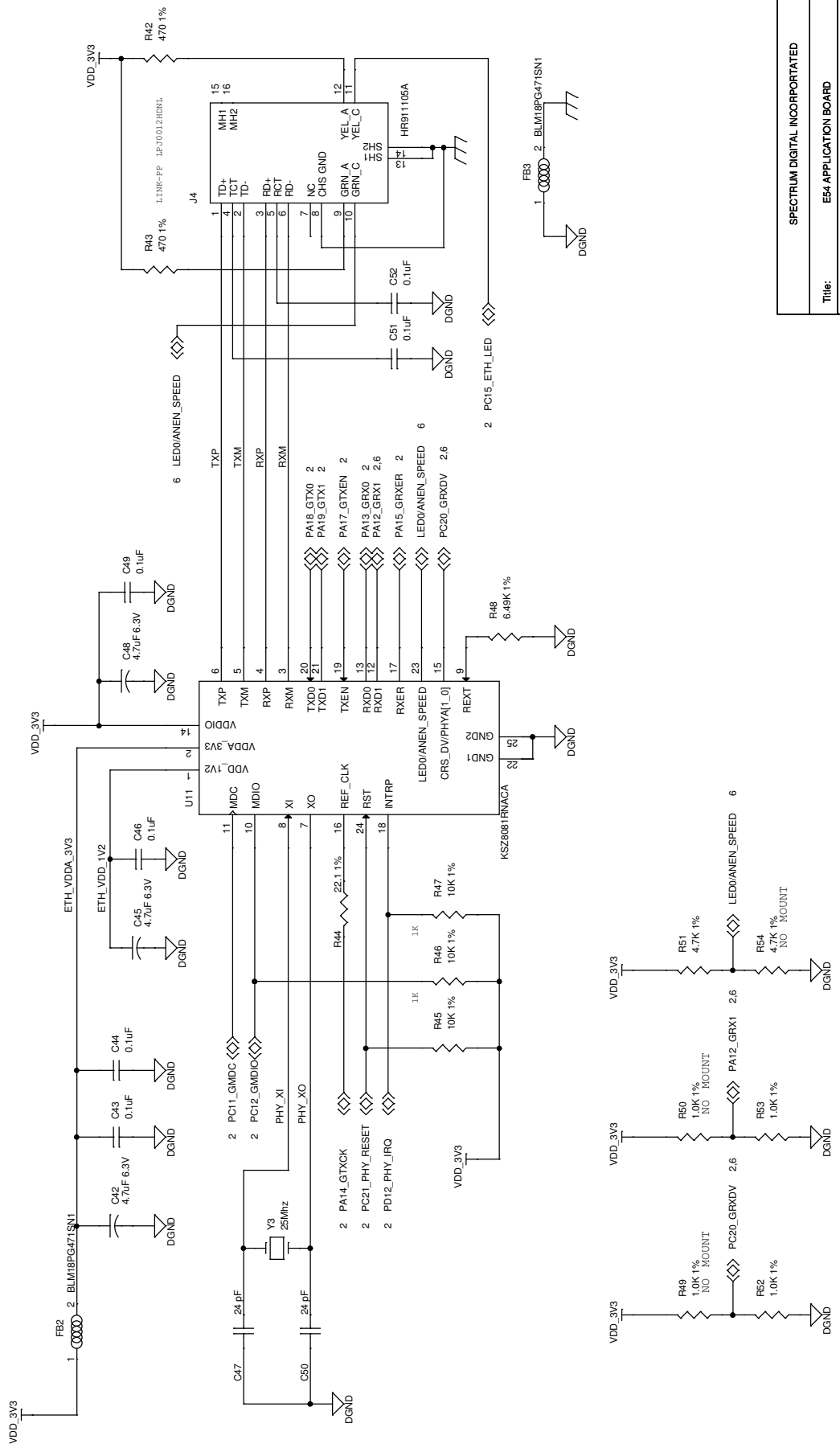

SPECTRUM DIGITAL INCORPORATED	
Title:	ES4 APPLICATION BOARD
Page Contents:	ETHERNET
Size: B	DWG NO 519192
Date: Friday, March 13, 2020	Revision: B
Sheet 6 of 7	

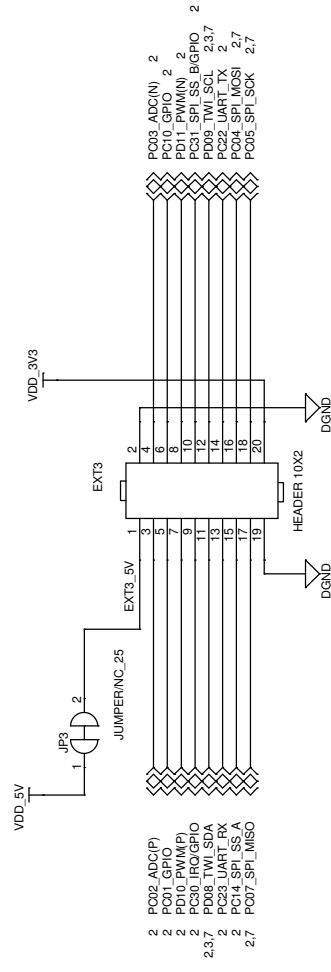
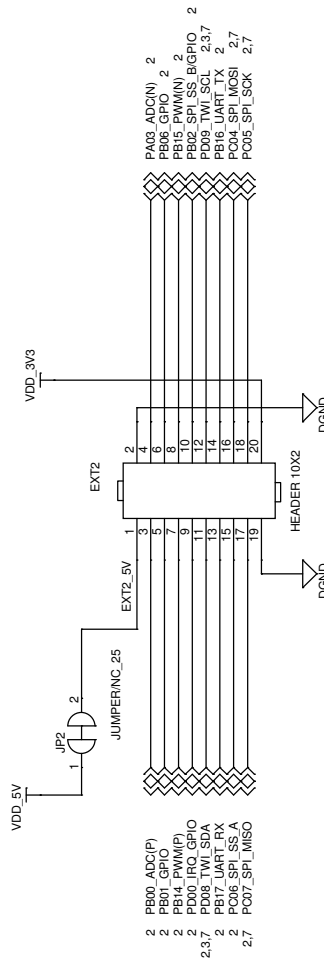
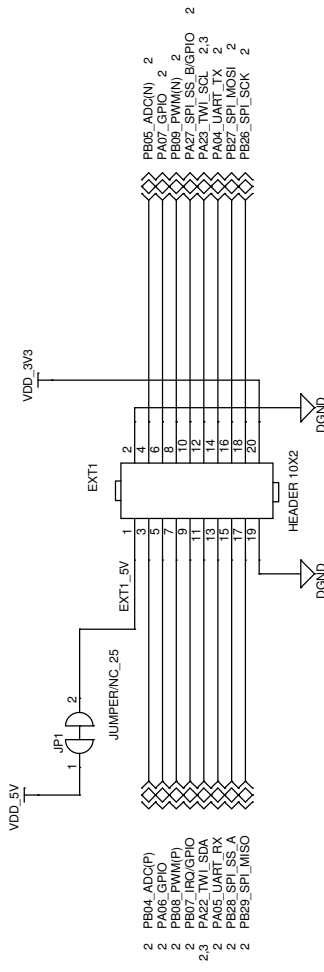

SPECTRUM DIGITAL INCORPORATED			
E54 APPLICATION BOARD			
Page Contents:		EXPANSION	
Size: B	DWG NO	519192	Revision: B
Date: Friday, March 13, 2020	Sheet 7 of 7		

Spectrum Digital, Inc
PO Box 1559
Sugar Land, TX. 77487-1559

Web site: www.spectrumdigital.com
Sales: sales@spectrumdigital.com
Support: support@spectrumdigital.com

Copyright Spectrum Digital Inc, © 2020

519198-4001