

303-264

SHURESEAL™ STRAIN RELIEF CONNECTORS



DESIGN FEATURES

- cable diameter up to 15.8mm
- non-corrosive thrust washer prevents cable twist
- ribbed steel gland nut for easy installation
- special double taper neoprene compression liquid tight seal. Weatherproof protection to IP66.
- steel body

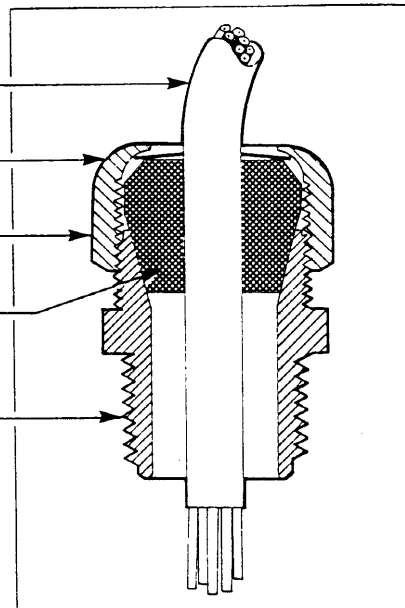

DISTRIBUTOR PREFERRED STOCK ITEMS ARE PRINTED IN BLUE

Cat. No.	Body Thread Form & Size	Cable Dia. mm		Unit Qty.	Std. Pkg.
		min.	max		
2520	1/2" N.P.T.	3.2	6.3	25	100
2521		6.3	9.5	25	100
2522		9.5	12.7	25	100
2523		11.4	14.2	25	100
2524*		12.7	15.8	25	100
6521	3/4" IMPERIAL	6.3	9.5	25	100
6522		9.5	12.7	25	100
6523		11.4	14.2	25	100
6524*		12.7	15.8	25	100
9520	20mm ISOMETRIC	3.2	6.3	25	100
9521		6.3	9.5	25	100
9522		9.5	12.7	25	100
9523		11.4	14.2	25	100
9524*		12.7	15.8	25	100

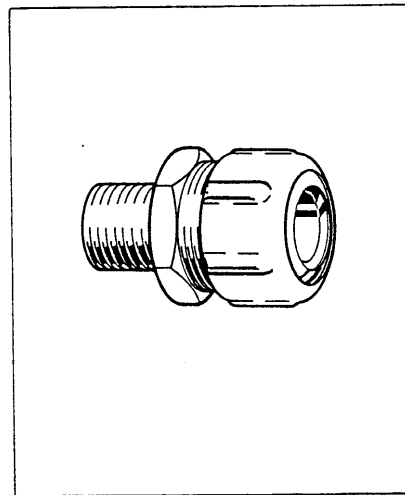

*Remove sufficient outer covering of cable to permit cores to pass through body.

CAT. NO.	CAT. NO.	CAT. NO.	DIMENSIONS mm		
			A	B	C
2520		9520	42.0	28.6	14.3
2521	6521	9521	42.0	28.6	14.3
2522	6522	9522	42.0	28.6	14.3
2523	6523	9523	42.0	28.6	14.3
2524	6524	9524	44.5	34.9	15.0

