

The FPSI 1010-1 is a 3-level voltage indicator which is designed to be easily panel mounted. The module compares an input voltage to a defined voltage window. The colour of the display shows whether the input voltage is below, within or above this window. The indicator is powered from a 7 to 24Vd.c. supply and provides a red-green-red bright LED indication over a 0 to 30Vd.c. measurement range. The user can easily set the colour switching thresholds. Hysteresis is built-in to avoid chattering at the colour switching thresholds. The module incorporates 1 trigger output, allowing the user to drive an external alarm or control a process being monitored. A low power mode is included (factory default setting), whereby the module indicates the voltage level by flashing the relevant colour, instead of indicating solid colours. Connection is via screw terminals. The module features a square plastic snap-in bezel, requiring a 12.6 x 12.6mm (0.5 x 0.5") cut-out.

## FEATURES

- Bright Red and Green Indication
- 0 to 30Vd.c. Measurement Range
- 7 to 24Vd.c. Supply Voltage
- 2 User Programmable Thresholds
- 1 Control Output (Negative Logic)
- Low Power Mode
- Snap-in Plastic Bezel
- Screw Terminal Connections
- Easy to Set up and Use

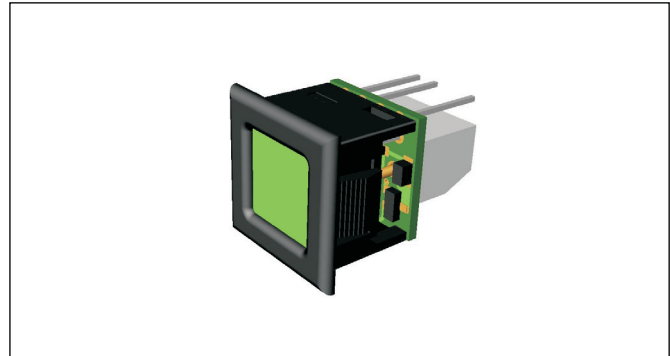

## TYPICAL APPLICATIONS

- Go - No Go Indication
- Level Monitoring
- Alarm Indication
- Control

## ORDERING INFORMATION

Standard Indicator	Stock Number FPSI 1010-1
--------------------	-----------------------------

## ELECTRICAL SPECIFICATIONS

Specification	Min.	Typ.	Max.	Unit
Supply voltage (V+ to 0V)	7.0		24.0*	Vd.c.
Supply current	Display not flashing	15		mA
	Display flashing (average current)		2.5	mA
Input Voltage (Vin to 0V)	0		30	Vd.c.
Internal resolution		30		mVd.c.
Accuracy (overall error)		2		%
Temperature stability		100		ppm/°C
Hysteresis		2		%
Sample rate		4		Samples/sec
Operating temperature range	-30		50	°C
Input impedance (unscaled input)		1		kOhm
Output High Voltage (Alm)	4.175		5.125	Vd.c.
Output High Current (Alm)			1	mA
Output Low Voltage (Alm)	0		0.6	Vd.c.
Output Low Current (Alm)			1	mA

\* Operation of the indicator beyond the maximum supply voltage rating may cause permanent damage to the indicator.

## SAFETY

To comply with the Low Voltage Directive (LVD 93/68/EEC), input voltages to the module's terminals must not exceed 60Vdc. The user must ensure that the incorporation of the FPSI 1010-1 into the user's equipment conforms to the relevant sections of BS EN 61010 (Safety Requirements for Electrical Equipment for Measuring, Control and Laboratory Use).

LASCAR ELECTRONICS LTD.  
MODULE HOUSE  
WHITEPARISH  
WILTSHIRE SP5 2SJ  
UK  
TEL: +44 (1794) 884567  
FAX: +44 (1794) 884616  
E-mail: sales@lascar.co.uk

LASCAR ELECTRONICS INC.  
3750 West 26th Street  
Erie  
PA 16506  
USA  
TEL: +1 (814) 835 0621  
FAX: +1 (814) 838 8141  
E-mail: us-sales@lascarelectronics.com

LASCAR ELECTRONICS (HK) LIMITED  
FLAT C, 5/F., LUCKY FTY. BLDG.  
63-65 HUNG TO ROAD  
KWUN TONG KOWLOON  
HONG KONG  
TEL: +852 2797 3219  
FAX: +852 2343 6187  
E-mail: b4lascar@samsongroup.com.hk

Specifications liable to change without prior warning

FPSI 1010-1

Issue 1

July/2003

M.C.

Applies to FPSI 1010/2



## CIRCUIT DIAGRAM

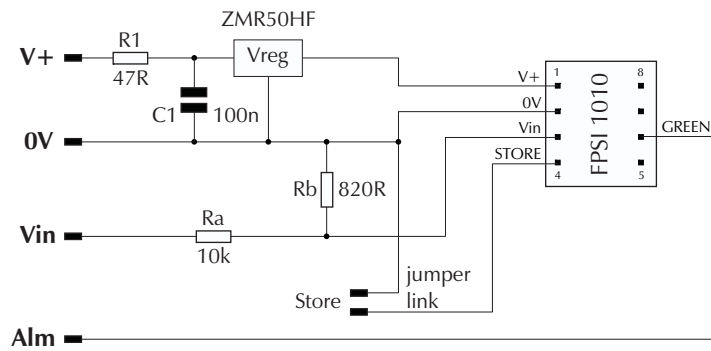

## FLASHING MODE TIMING

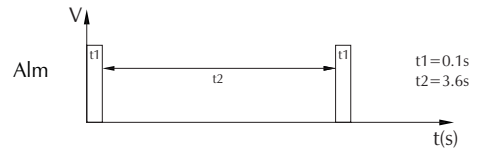

## DIMENSIONS All dimensions in mm (inches)

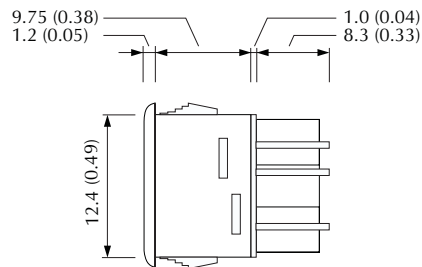
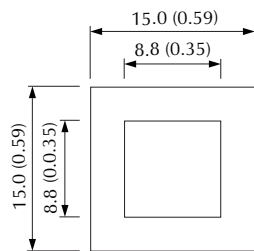

Panel cut-out:  
12.6 x 12.6mm (0.5 x 0.5)

Panel thickness:  
1 to 3 mm (0.04 to 0.12)

## CONFIGURING THE LEVEL INDICATOR

The indicator is factory configured with colour switching thresholds, as follows:

V1 = 11.0V (nom.)

V2 = 22.0V (nom.)

To change this setting, proceed as follows.

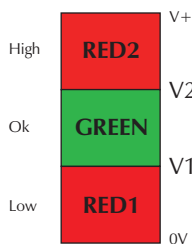
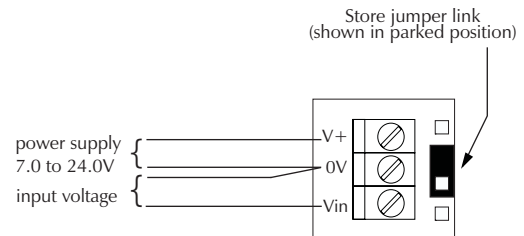

### Step 1

- Remove the Store jumper link.
- Connect V+ and 0V of the FPSI 1010-1 to a 7.0 to 24.0Vd.c. supply.

### Step 2

- Apply the first desired voltage (V1) to Vin.
- Place the Store jumper link over the 2 pins.
- Remove the Store jumper link.
- The module flashes Green to indicate that the V1 level has been stored.

### Step 3

- Apply the second desired voltage (V2) to Vin.
- Place the Store jumper link over the 2 pins.
- Remove and park the Store jumper link.
- The module flashes Red to indicate that the V2 level has been stored.

### Step 4

- To enter solid LED mode, make sure Vin does not change.
- To enter flashing LED mode (factory default), change Vin by 100mV or more.
- Place the Store jumper link over the 2 pins.
- Remove and park the Store jumper link.
- Module flashes Red or Green to indicate that the display mode has been stored.

### Step 5

- Disconnect the module. The module is now ready for use.

## SCREW TERMINAL FUNCTIONS

- V+** Positive power supply to the status indicator.
- 0V** Negative power supply to the status indicator.
- Vin** Measuring input with reference to 0V.
- Alm** This digital output terminal goes Low (0V) when the voltage on Vin is
  - lower than the switching threshold V1 or
  - higher than the switching threshold V2.

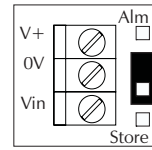

Rear View

## APPLICATIONS

Do not connect more than one FPSI 1010-1 to the same power supply if the units cannot use the same signal ground. Taking any input beyond the power supply rails will damage the FPSI 1010-1.

**Note:** If the FPSI 1010-1 module is configured for flashing mode, then the Alm output will also pulse High and Low (see Flashing Mode Timing section of this datasheet).

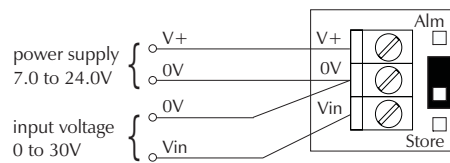

### Basic operation

- The indicator is :
- red when the Vin voltage is between 0V and V1 (Low)
  - green when the Vin voltage is between V1 and V2 (Ok)
  - red when the Vin voltage is between V2 and V+ (High)

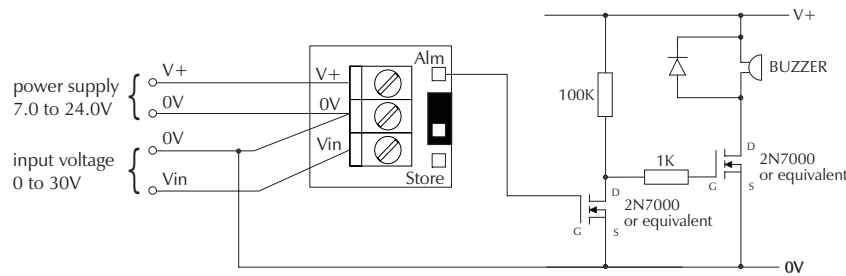

### Driving a Buzzer

The Alm output is shown driving a buzzer. Alm must not be allowed to source more than 1mA.

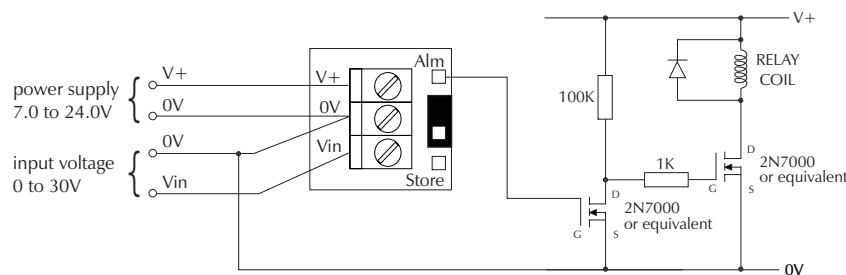

### Driving a Relay

The Alm output is shown driving a relay. Alm must not be allowed to source more than 1mA.

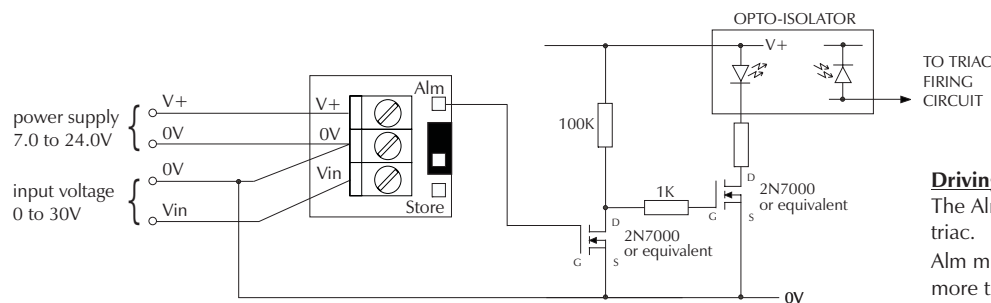

### Driving a Triac

The Alm output is shown driving a triac. Alm must not be allowed to source more than 1mA.

Bottom View  
of 2N7000



Consult the MOSFET datasheet for maximum drain current.