

# Wide Opening Air Gripper

## Series MHL2

Parallel Style/ø10, ø16, ø20, ø25, ø32, ø40

### How to Order

MHL 2-16 D 1-Y59A S

Wide opening

Numbers of fingers

2	2 fingers
---	-----------

Thread Port (ø32 to ø40)

—	Rc(PT)
E	G(PF)

Bore size

10	10mm
16	16mm
20	20mm
25	25mm
32	32mm
40	40mm

Action

D	Double Acting
---	---------------

Opening/closing stroke (mm)

Symbol	ø10	ø16	ø20	ø25	ø32	ø40
—	20	30	40	50	70	100
1	40	60	80	100	120	160
2	60	80	100	120	160	200

Number of auto switches

—	2
S	1
n	n

Auto switch

—	Without auto switch (Built-in magnet)
---	---------------------------------------

Auto switch specifications

Type	Special function	Electrical entry	Indicator light	Wiring (Output)	Load voltage		Auto switch model no.		Lead wire length (m) <sup>†</sup>		Applicable load
					DC	AC	Perpendicular	In-line	0.5 (—)	3 (L)	
Solid state switch	—	Grommet	With	3 wire (NPN)	5V, 12V	—	Y69A	Y59A	●	●	IC circuit
				3 wire (PNP)			Y7PV	Y7P	●	●	
				2 wire	12V	Y69B	Y59B	●	●		
				3 wire (NPN)		Y7NWV	Y7NW	●	●	IC circuit	
	3 wire (PNP)			5V, 12V	Y7PWV	Y7PW	●	●			
	2 wire				12V	Y7BWV	Y7BW	●	●	—	
	Water resistant (2 colour)			—	Y7BA*	—	●	—	—	Relay, PLC	

\*Lead wire length symbol: 0.5m..... (Example) Y59B  
3m.....L (Example) Y59BL



Refer to p.2.11-1 for auto switch specifications.  
\*Y7BA is applicable to "-X5" oil proof type (p.2.2-6).

# Wide Opening Air Gripper Series **MHL2**

One unit can handle workpieces with various diameters

A large amount of gripping force is provided through the use of a double piston mechanism, while maintaining a compact design

Double end type oil impregnated resin bearings with a metal backing are used for all shafts

Fingers synchronized by a rack and pinion mechanism

Built-in dust proofing mechanism

A high degree of freedom for mounting

Auto switch capable



 P.2.2-6

Symbol

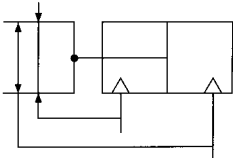

## Specifications

Bore size (mm)	10	16	20	25	32	40
Fluid	Air					
Action	Double acting					
Operating pressure (MPa)	0.15 to 0.6		0.1 to 0.6			
Ambient and fluid temperature	-10 to 60°C					
Repeatability	±0.1					
Lubrication	Not required					
Effective holding force (N) at 0.5MPa <sup>(1)</sup>	14	45	74	131	228	396



Note 1) Holding point = Bore size 10, 16, 20, 25: 40mm, Bore size 32, 40: 80mm.

## Model/Stroke

Model	Bore size (mm)	Max operating frequency (c.p.m)	Opening/closing stroke (L2-L1)(mm)	Width at closing (mm) (L1)	Width at opening (mm) (L2)	Weight (g)
MHL2-10D	10	60	20	56	76	280
MHL2-10D1		40	40	78	118	345
MHL2-10D2			60	96	156	425
MHL2-16D	16	60	30	68	98	585
MHL2-16D1		40	60	110	170	795
MHL2-16D2			80	130	210	935
MHL2-20D	20	60	40	82	122	1025
MHL2-20D1		40	80	142	222	1495
MHL2-20D2			100	162	262	1690
MHL2-25D	25	60	50	100	150	1690
MHL2-25D1		40	100	182	282	2560
MHL2-25D2			120	200	320	2775
MHL2-32D	32	30	70	150	220	2905
MHL2-32D1		20	120	198	318	3820
MHL2-32D2			160	242	402	4655
MHL2-40D	40	30	100	188	288	5270
MHL2-40D1		20	160	246	406	6830
MHL2-40D2			200	286	486	7905



Note) The open and close time spans represent the value when the exterior of the workpiece is being held.

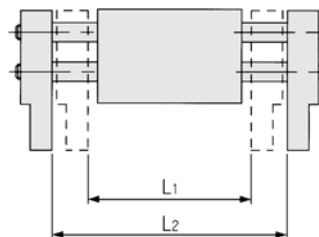

## Caution

Be sure to read before handling.

Refer to p.0-20 and 0-21 for Safety Instructions and common precautions on the products mentioned in this catalogue, and refer to p.2.0-3 and 2.0-4 for precautions on every series.

## Warning

If a workpiece is hooked onto the attachment, make sure that excessive impact will not be created at the start and the end of the movement. Failure to observe this precaution may result in shifting or dropping the workpiece, which could be dangerous.

MHZ

MHQ

**MHL2**

MHR

MHK

MHS

MHC2

MHT2

MHY2

MHW2

MRHQ

Auto switch

**MHL2-10D**

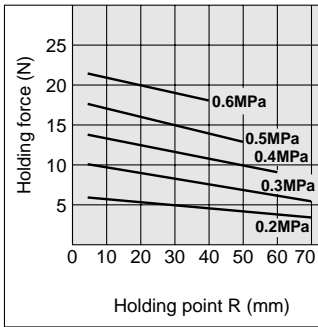

**MHL2-10D**

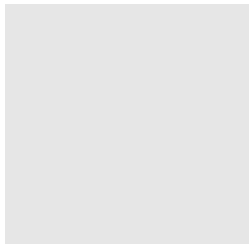

**MHL2-16D**

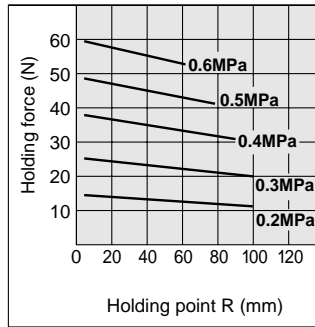

**MHL2-20D**

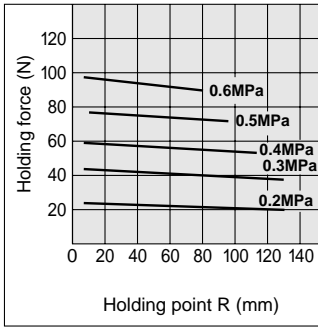

**MHL2-20D**

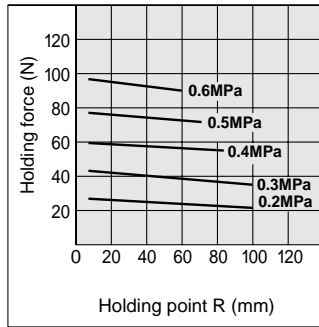

**MHL2-25D**

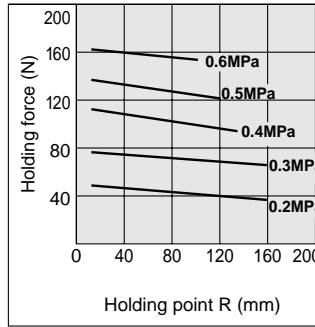

**MHL2-25D**

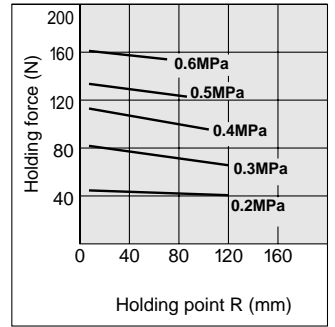

**MHL2-32D**

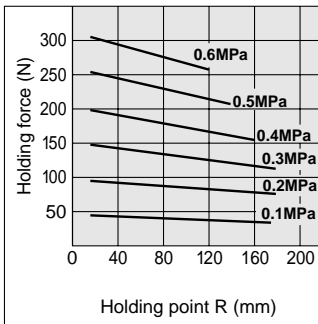

**MHL2-40D**

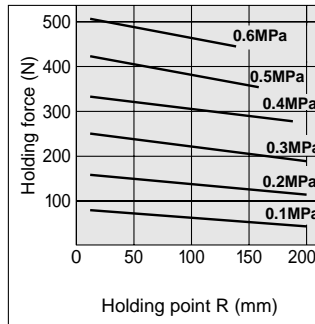

**MHL2-40D**

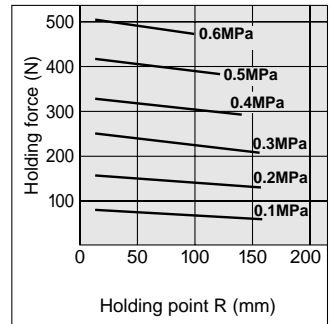

## Example of Model Selection

Procedures **Check conditions** → **Select possible points according to the work length** → **Calculate of required holding force** → **Model selection from holding force graph**

Work form  
Diameter X Length  
200mm X 20mm plate

Work diameter: From dimensions of model "that" has opening width 28mm or more.  
**MHL2-16D2**  
**MHL2-20D1, D2**  
**MHL2-25D1, D2**

Work weight: 0.3kg

Guidelines on model selection according to work weight

- Although the condition differs according to the coefficient of friction between the attachment and work, select a model that can produce a holding force 10 to 20 times the work weight.
- Further allowance should be provided when great acceleration or impact is expected during work transfer.

Ex.) For setting the holding force to be at least 20 times the work weight:  
Required holding force =  $0.3\text{kg} \times 20 \times 9.8\text{m/s}^2 \approx 60\text{N}$

Holding point R = 70mm

Operating pressure: 0.5MPa

**MHL2-20D<sub>1</sub>**

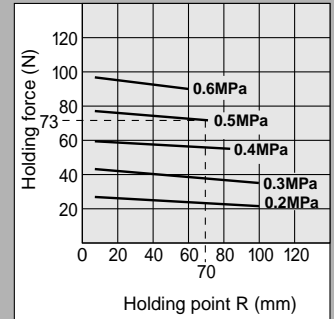

If it is not particularly necessary to locate the workpiece, and the air gripper is to be used by merely hooking the workpiece to the attachment, it is possible to move a workpiece that has a weight that is proportionate to the gripping force.

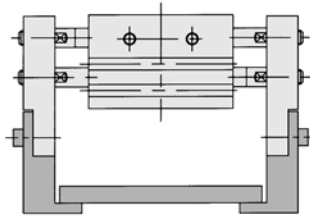

MHZ

MHQ

**MHL2**

MHR

MHK

MHS

MHC2

MHT2

MHY2

MHW2

MRHQ

Auto switch

# Series MHL2

## Construction

ø10

ø16 to ø25

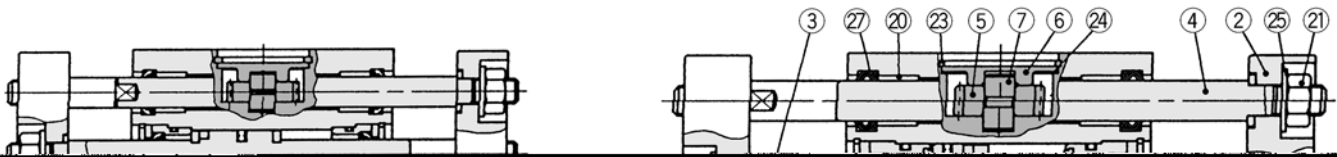

### Component Parts

No.	Description	Material	Note
①	Body	Aluminum alloy	Anodized
②	Finger	Aluminum alloy	Anodized
③	Piston rod	Stainless steel	
④	Rack	Stainless steel	
⑤	Pinion	Carbon steel	
⑥	Pinion cover	Carbon steel	Electroless nickel plated
⑦	Pinion axis	Stainless steel	Nitriding
⑧	Piston	Brass	
⑨	Piston A	Brass	
⑩	Piston B	Brass	
⑪	Piston A	Stainless steel	
⑫	Rod cover	Aluminum alloy	Chromate treated
⑬	Damper	Urethane rubber	
⑭	Clip	Stainless steel wire for spring	
⑮	Rubber magnet	Synthetic rubber	

No.	Description	Material	Note
⑰	Magnet	Magnet material	Nickel plated
⑱	Rod seal cover B	Cold-rolled steel	Electroless nickel plated
⑲	Washer	Stainless steel	Nitriding
⑳	Bearing	Oil containing polyacetal with back metal	
㉑	Bearing	Oil containing polyacetal with back metal	
㉒	U nut	Carbon steel	Nickel plated
㉓	R-shape snap ring	Carbon steel	Nickel plated
㉔	C-shape snap ring	Carbon steel	Nickel plated
㉕	Wave washer	Steel for spring	Phosphate coating
㉖	Conical spring washer	Carbon steel	Nickel plated

### Replacement Parts/Seal Kits

No.	Description	Material	Kit No.					
			MHL2-10D□	MHL2-16D□	MHL2-20D□	MHL2-25D□	MHL2-32D□	MHL2-40D□
㉗	Seal kit <sup>Note)</sup>	NBR	MHL10-PS	MHL16-PS	MHL20-PS	MHL25-PS	MHL32-PS	MHL40-PS
㉘								
㉙								
㉚								
㉛								

Note) No. ㉗, ㉘, ㉙, ㉚, ㉛ are included.

## Setting Method of Auto Switch

To set the auto switch, insert the auto switch into the switch groove of the air gripper from the direction indicated in the following drawing. After setting the position, tighten the attached switch mounting set screw with a straight bladed watchmakers screwdriver.

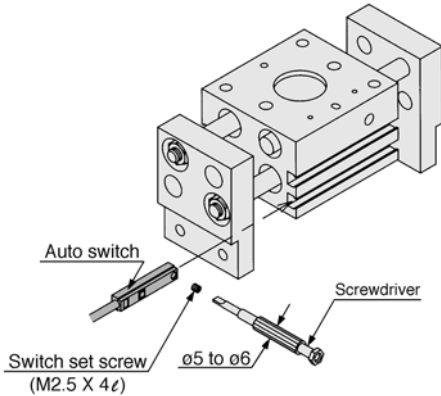

Note) Use a watchmakers screwdriver with a grip diameter of 5 to 6mm to tighten the auto switch set screw. Use a tightening torque of 0.05 to 0.1 Nm. As a rough guide, tighten the screw an additional 90° after feeling a tight resistance.

## Auto Switch Hysteresis

Auto switch hysteresis is as follows. Please refer to the table as a guide when setting auto switch positions.

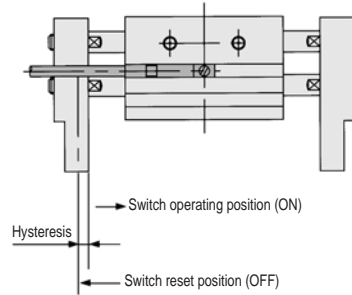

Unit: mm

Air gripper	Auto switch model	D-Y59 <sup>Ⓐ</sup> D-Y69 <sup>Ⓐ</sup>	D-Y7 <sup>Ⓑ</sup> W	D-Y7 <sup>Ⓑ</sup> WV	D-Y7BA
	MHL2-10D□		0.8	0.6	0.7
MHL2-16D□		0.5	0.3	0.3	0.2
MHL2-20D□		0.5	0.2	0.3	0.2
MHL2-25D□		0.2	0.2	0.2	0.1
MHL2-32D□		0.4	0.7	0.7	0.4
MHL2-40D□		0.2	0.7	0.6	0.4

# Made to Order Specifications

## 1 Oil proof

MHL2  D  Solid state switch -X 5

The packing class has been revised to adopt oil-proof materials for using it in an environment with splashing of cut liquid splashing etc.

### Specifications

Type	Oil proof
Bore size	ø10, ø16, ø20 ø25, ø32, ø40
Action	Double acting
Fluid	Air
Material	Sealing, Gasket-Fluoro rubber
Applicable auto switch	D-Y7BAL

Note) Some liquid may make the use of an air gripper or auto switch impossible. Confirm the kind of the questionable liquid and consult SMC for the use. The dimensions are the same as the standard type.

## 2 Thermal proof

MHL2  D  -X 4

The packing class has been revised to adopt thermal proof materials for using it at high temperature of up to 100°C.

### Specifications

Type	Thermal proof
Bore size	ø10, ø16, ø20, ø25, ø32, ø40
Action	Double acting
Fluid	Air
Material	Sealing, Gasket-Fluoro rubber

Note) Items with auto switch can not be manufactured. The dimensions are the same as the standard type.

MHZ

MHQ

**MHL2**

MHR

MHK

MHS

MHC2

MHT2

MHY2

MHW2

MRHQ

Auto switch

## Dimensions

# MHL2-10D□

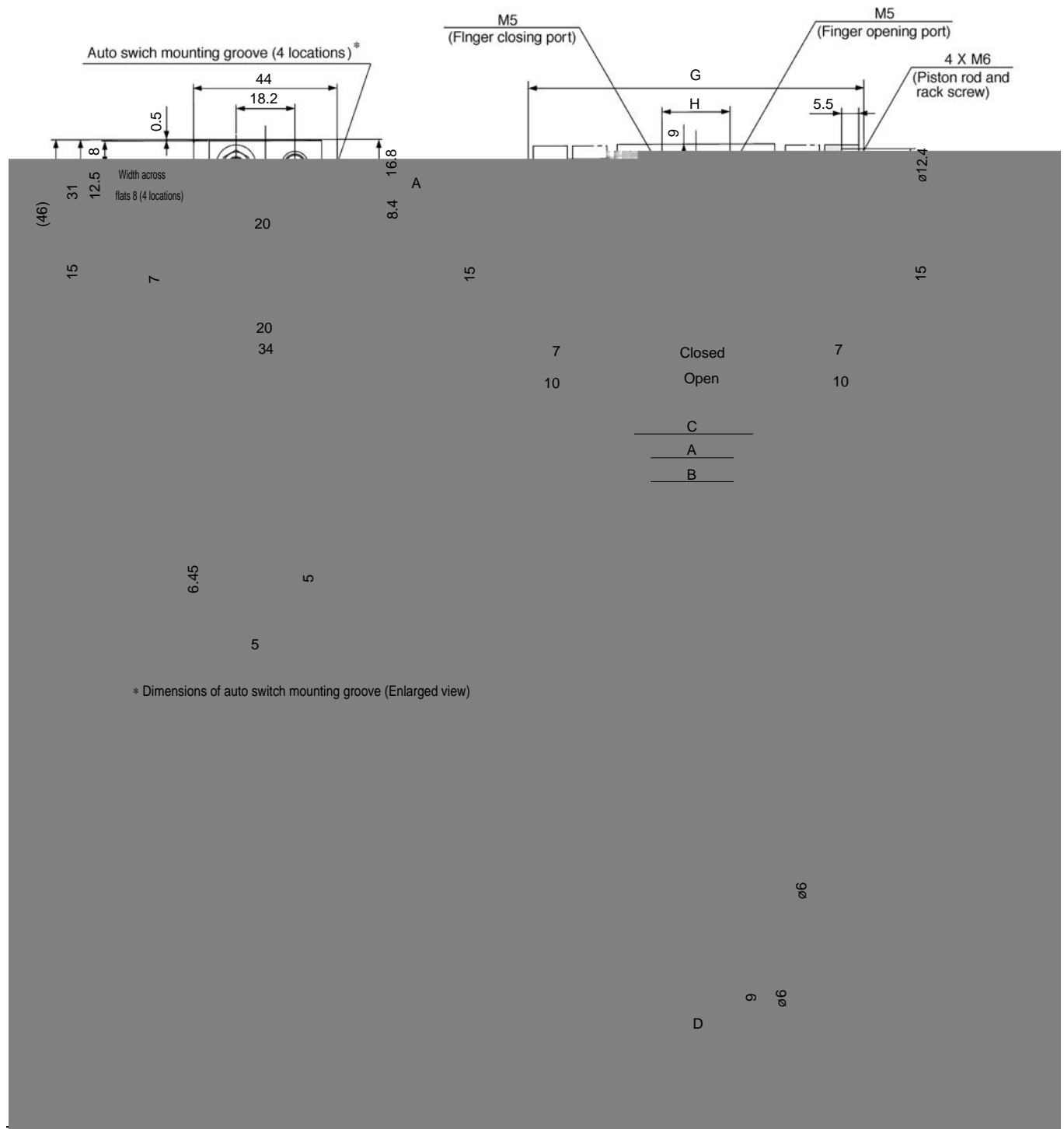

Model	A	B	C	D	E	F	G	H	J
MHL2-10D	38	36	51	26	56	76	100	24	80
MHL2-10D1	54	52	67	42	78	118	142	39	108
MHL2-10D2	72	70	85	60	96	156	180	57	146



Note 1) J dimension is at fully closed.

Note 2) D1 is different from D2 at finger closed because shaft is ejected from finger end. J dimension is different from the value which is subtracted stroke from G dimension.

# Wide Opening Air Gripper Series **MHL2**

## Dimensions

### MHL2-16D□

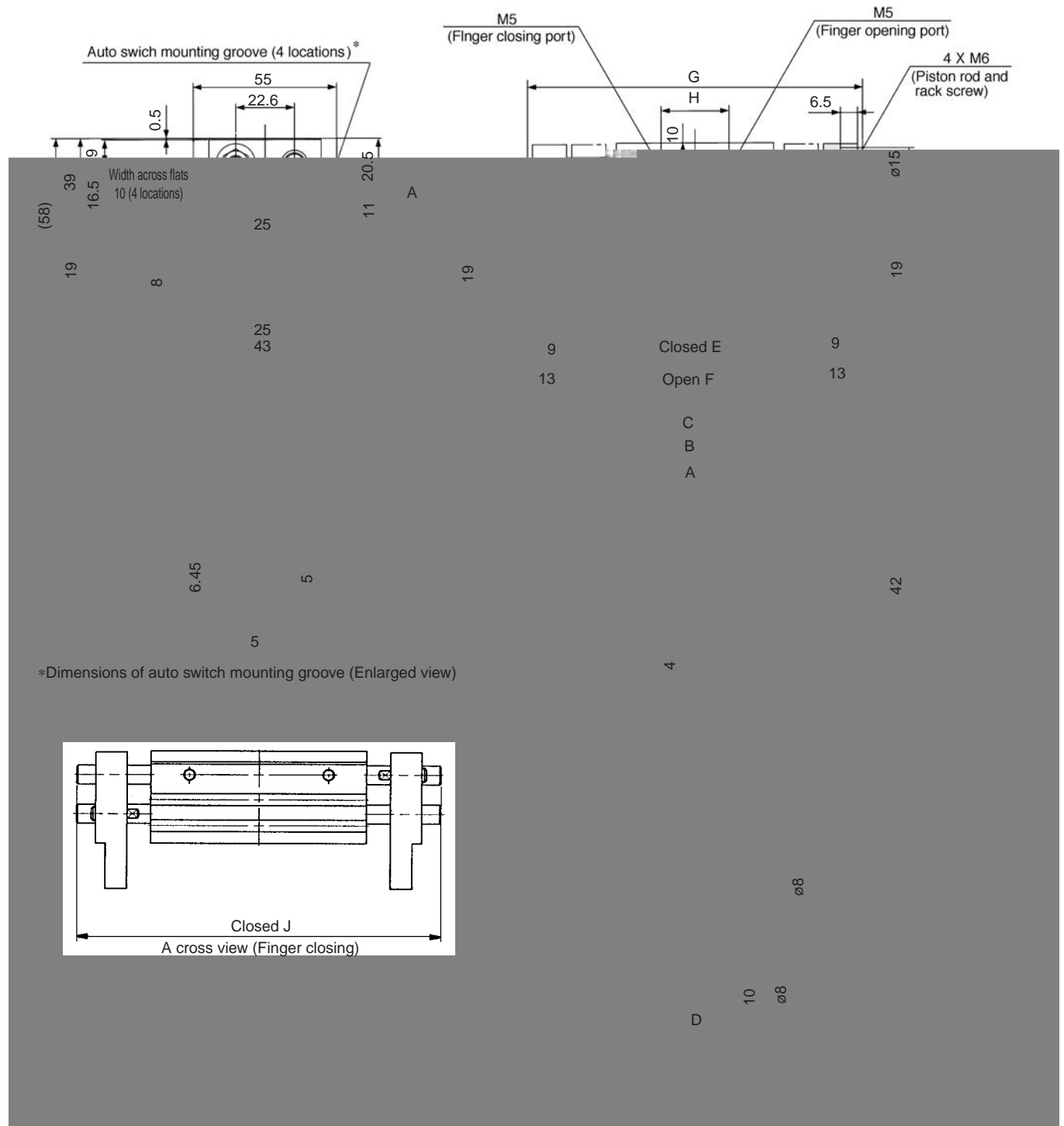

Model	A	B	C	D	E	F	G	H	J
MHL2-16D	40	45	60	28	68	98	128	26	98
MHL2-16D1	70	75	90	58	110	170	200	50	152
MHL2-16D2	90	95	110	78	130	210	240	70	192

Notes) J dimension is at fully closed position.  
 D1 is different from D2 at finger closed position because shaft is ejected from finger end. J dimension is different from the value which is subtracted stroke from G dimension.





# Wide Opening Air Gripper Series **MHL2**

## Dimensions

### MHL2-25D□

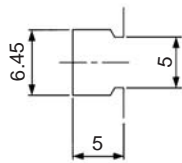
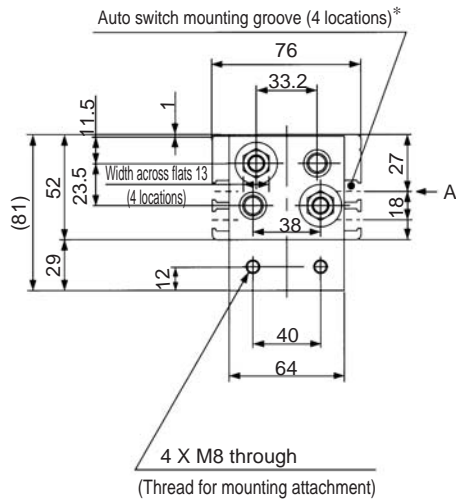

\*Dimensions of auto switch mounting groove (Enlarged view)

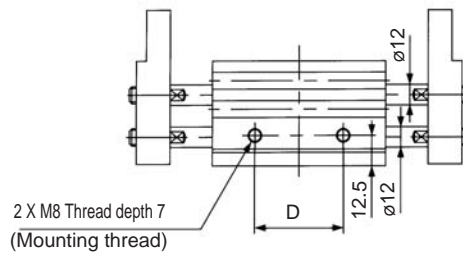
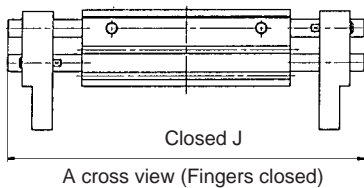
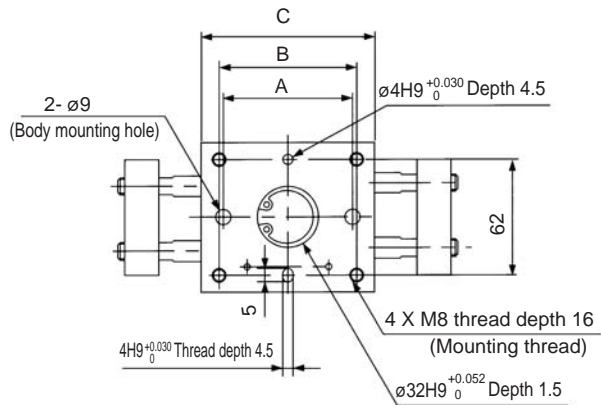
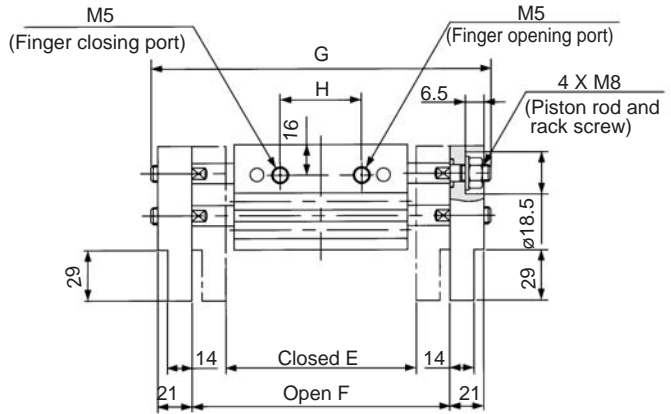

Model	A	B	C	D	E	F	G	H	J
MHL2-25D	66	70	88	48	100	150	196	38	146
MHL2-25D1	120	124	142	102	182	282	328	86	244
MHL2-25D2	138	142	160	120	200	320	366	104	282



Note 1) J dimension is at fully closed.

Note 2) D1 is different from D2 at finger closed because shaft is ejected from finger end.  
J dimension is different from the value which is subtracted stroke from G dimension.

MHZ

MHQ

**MHL2**

MHR

MHK

MHS

MHC2

MHT2

MHY2

MHW2

MRHQ

Auto switch

# Series MHL2

## Dimensions

### MHL2-32D□

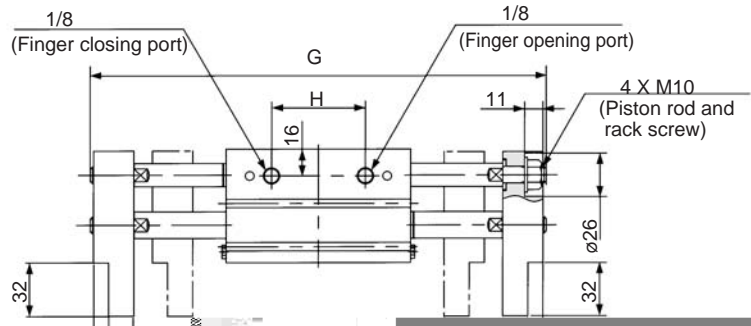
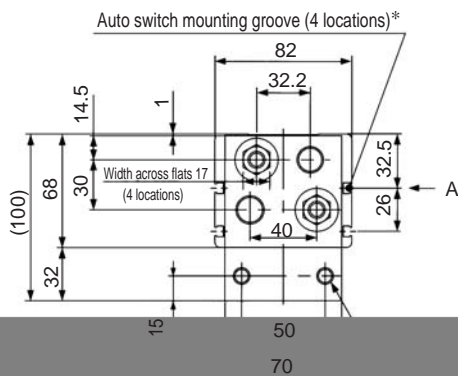

4 X M10 through  
(Thread for mounting attachment)

6.45  
5  
5

\*Dimensions of auto switch mounting groove (Enlarged view)

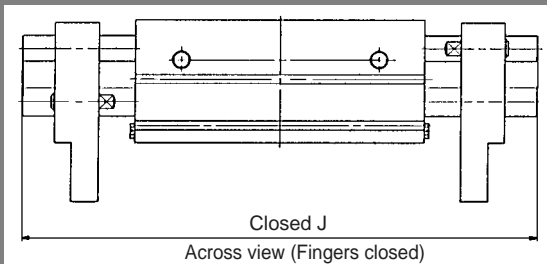

6H9<sup>+0.030</sup><sub>0</sub> Depth 8

4 X M8 Thread depth 16  
(Mounting thread)

ø35H<sup>+0.062</sup><sub>0</sub> Depth 2.5

ø16

2 X M8 Thread depth 11  
(Mounting thread)

D

22

ø14

Model	B	C	D	E	F	G	H	J
MHL2-32D	86	110	60	150	220	272	56	202
MHL2-32D1	134	158	108	198	318	370	104	282
MHL2-32D2	178	202	152	242	402	454	148	366



Note 1) J dimension is at fully closed.

Note 2) D1 is different from D2 at finger closed because shaft is ejected from finger end.

J dimension is different from the value which is subtracted stroke from G dimension.

# Wide Opening Air Gripper Series **MHL2**

## Dimensions

### MHL2-40D□

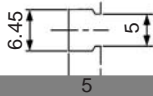
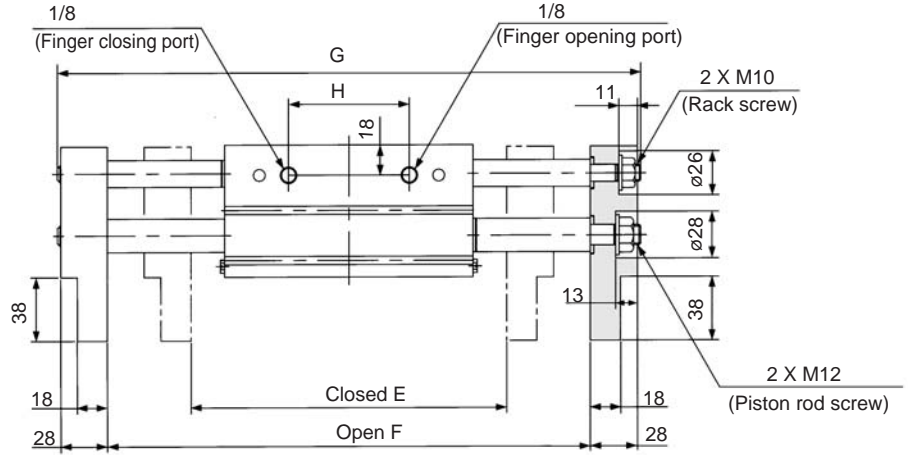
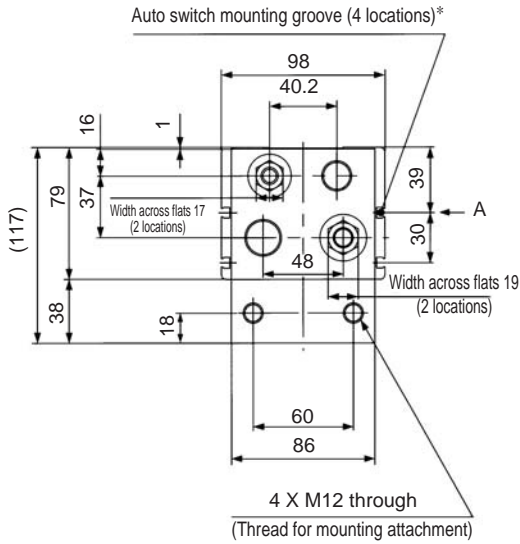

\*Dimensions of auto switch mounting groove (Enlarged view)

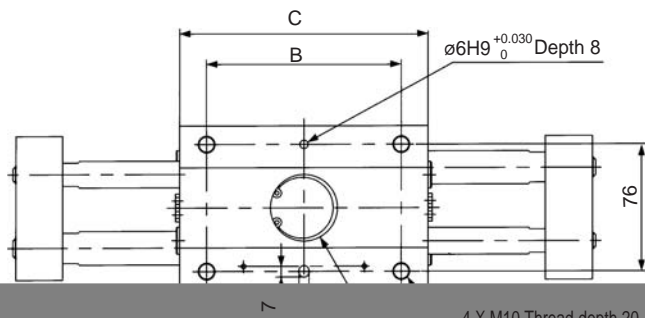

6H9<sup>+0.030</sup><sub>0</sub> Depth 8

4 X M10 Thread depth 20  
(Mounting thread)

40H9<sup>+0.062</sup><sub>0</sub> Depth 2.5

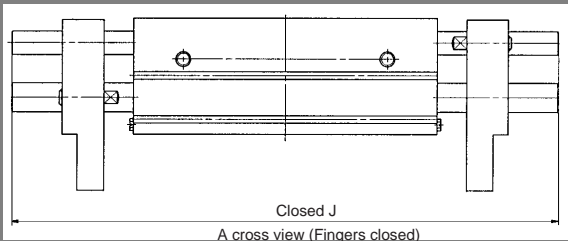

2 X M10 Thread depth 12  
(Mounting thread)

D

28

ø16

ø20

MHZ

MHQ

**MHL2**

MHR

MHK

MHS

MHC2

MHT2

MHY2

MHW2

MRHQ

Auto switch

Model	B	C	D	E	F	G	H	J
MHL2-40D	116	148	80	188	288	348	72	252
MHL2-40D1	174	206	138	246	406	466	130	336
MHL2-40D2	214	246	178	286	486	546	170	450



Notes) J dimension is at fully closed.

D1 is different from D2 at finger closed because shaft is ejected from finger end.

J dimension is different from the value which is subtracted stroke from G dimension.