

M-1 Series

Remote Line Input Modules



M-1W (White)



M-1B (Black)



M-1AW (White)



M-1AB (Black)

Installation Guide

Contents

Introduction	3
Mounting - mechanical	3
Faceplate Controls and Connections	4
Block Diagram	4
Installation - connections.....	5
M-1 Priority Operation.....	6
Power considerations.....	6

Introduction

The M-1 is a remote microphone input module for use with all Cloud host units fitted with a Facility Port, including:

- MA40F, MA40T and MA40E Mini Amplifiers
- MA80FT and MA80E Mini Amplifiers
- Z4MK4 and Z8MK4 Zone Mixers (also discontinued Z4MK3 and Z8MK3)
- 46-120 and 46-120MEDIA Zone Mixing Amplifiers
- 46-80 and 46-80T Mixing Amplifiers

NOTE: Unless specifically stated otherwise, all references to “M-1” in this Installation Guide can be taken to apply to all M-1 mechanical and cosmetic variants.

The M-1 module provides a remote input connection point for a microphone: it is intended to be installed in a zone where there are loudspeakers fed from the Cloud host unit. It enables the microphone to be heard in the same zone. A user-operated priority function activates the host unit’s VCA, automatically “ducking” any music currently routed to the zone while the microphone is in use.

The module faceplate has a standard XLR3F socket for connecting the microphone. Mic level may be adjusted on the module with the **MIC LEVEL** control. The M-1 is connected to a Facility Port on the host unit by a single screened Cat 5 cable with RJ45 connectors. DC power is supplied by the host unit via this connection.

NOTE: The M-1 module does not supply phantom power: condenser (capacitor) microphones cannot be used with the M-1.

Mounting - mechanical

M-1 (UK version)

The Cloud M-1 fits a standard UK-style single-gang electrical back box. The box used should have a depth of at least 35 mm.

M-1A (US version)

The Cloud M-1A is compatible with Decora housings, in vertical orientation. The housing should have a depth of at least 1½”.

Faceplate Controls and Connections

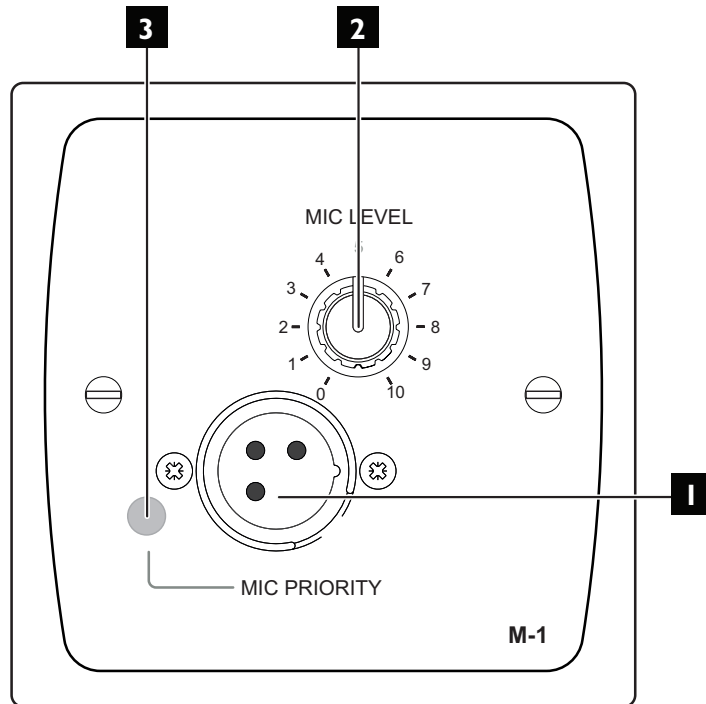

UK Version illustrated

1. **MIC INPUT** – balanced input using a XLR3F socket for connection of a microphone.
2. **MIC LEVEL** – level control for the microphone connected at [1]. The control has a very large gain range: in its fully anticlockwise position, the mic will effectively be muted.
3. **MIC PRIORITY** – pressing this button activates the host unit's priority circuitry to ensure that the microphone is audible over any music in the zone.

Block Diagram

Cloud M-1

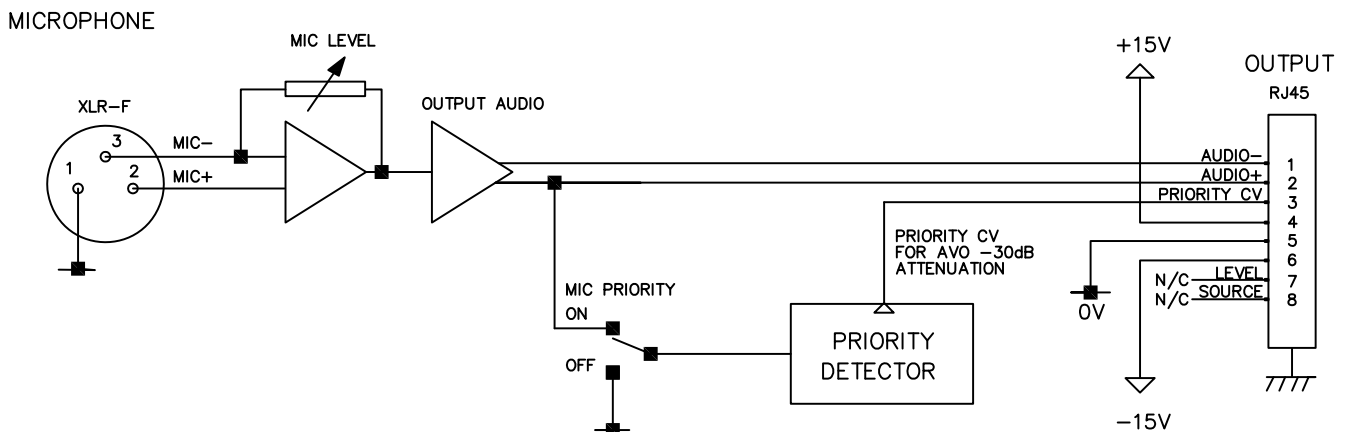

Installation - connections

Both the M-1 and M-1A have a single PCB fitted to the rear of the faceplate. The RJ45 connector marked SK1 is mounted on the PCB.

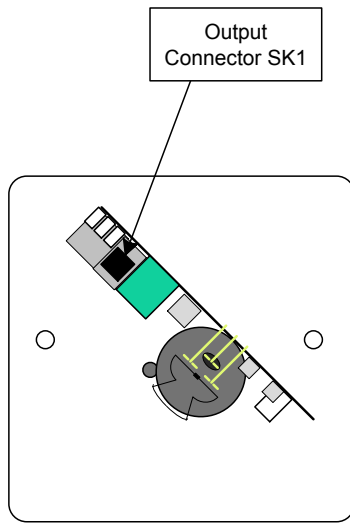

M-1 rear view: UK version

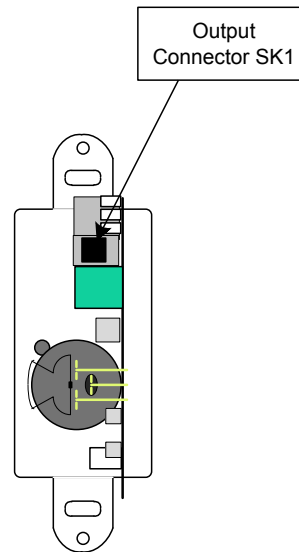

M-1A rear view: Decora version

The M-1's SK1 connector should be connected to the host unit's **FACILITY PORT** for the Zone in which it is installed* with screened Cat 5 cable and shielded RJ45 plugs. The Cat 5 cable length should not exceed 1000 m.

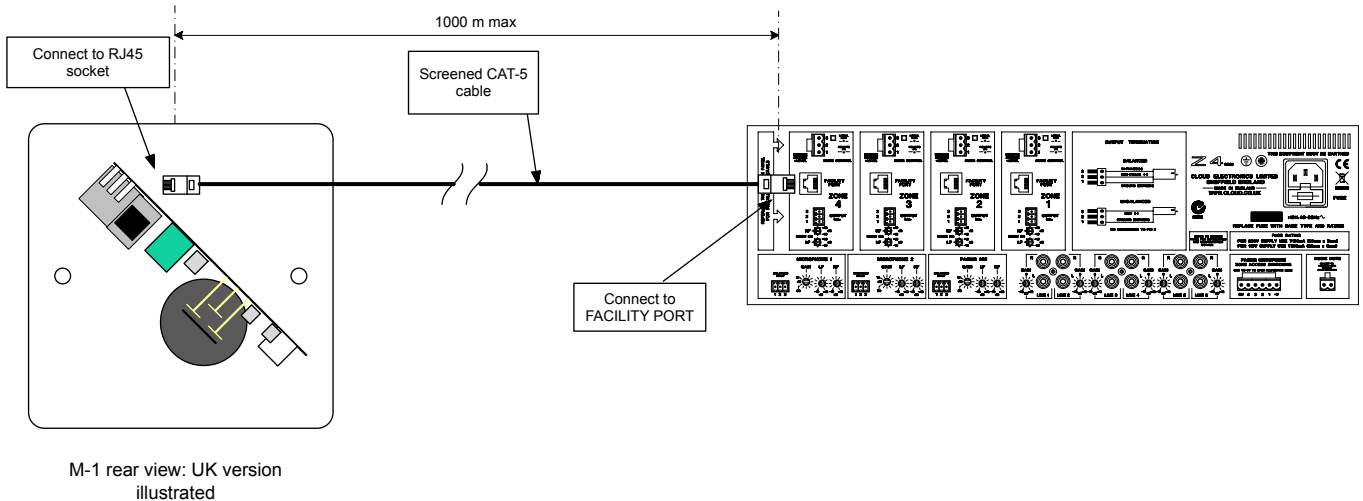

M-1 rear view: UK version illustrated

* There is no reason why the module cannot be connected to the Facility Port of a Zone other than that in which it is installed – though this is likely to be an unusual installation scenario.

IMPORTANT: Because the interconnecting cable carries low-level audio, *only* screened Cat 5 should be used, the foil screen of the cable being bonded to the metal screening can of the plugs. If an M-1 is being installed in very close proximity to the host unit, it may be possible to use ready-made screened Cat 5 “patch” cables of short length. In all other situations, shielded RJ45 plugs should be crimped onto the installed screened Cat 5 cable using the pinout shown below.

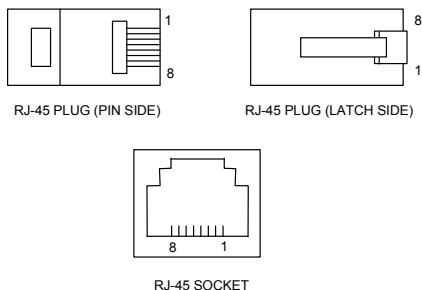

PIN	USE	Cat 5 CORE	
1	Audio 'cold' phase (-)	White + Orange	
2	Audio 'hot' phase (+)	Orange	
3	Priority VCA control	White + Green	
4	+15 V	Blue	
5	0 V	White + Blue	
6	-15 V	Green	
7	Music level control (0 to 10 V)	White + Brown	NB: Not used on the M-1
8	Music source select control (0 to 10 V)	Brown	
SCN	Screen for system music controls	Connector shell	

The microphone plugged into the M-1 module will be available in the Zone as soon as the module is connected to the host unit's Facility Port for that Zone. The mic volume may be adjusted with the **MIC LEVEL** control on the M-1 faceplate: this has a 138 dB (-88 dB to +50 dB); when fully anticlockwise, the mic is effectively muted. Note that the mic volume will be unaffected by any of the host unit's front panel controls.

M-1 Priority Operation

The M-1 contains a priority circuit which activates the host unit's mute circuitry through pin 3 of the RJ45 connector. This may be made active by pressing the **MIC PRIORITY** button. When the priority is active, and a mic signal is detected, the priority circuit will dim (or "duck") the music signal currently routed to the Zone by the host unit itself. The music signal will be reduced in level by approximately 30 dB. When the mic signal stops, the music volume will gradually restore to its original level. The attack time (how quickly the host music level drops when the mic is used) and release time (how quickly it recovers after the mic signal stops) are pre-set, and optimised for best audible results.

When **MIC PRIORITY** is not selected, any music routed to the zone will remain at its current level, and the microphone signal will be mixed with it.

It is important to note that any Priority functions set within the host unit – e.g., Line 6 Priority or Paging – will operate in other Zones as normal. However, if Line 6 Priority is selected for the Zone containing the M-1, and is active, the Line 6 source will still be ducked by the M-1's Priority. As the various Cloud host units provide slightly different priority facilities, installers should consult the Installation and User Guide for the host unit if further clarification is needed.

Power considerations

The M-1 is powered from the host unit's **FACILITY PORT** via the Cat 5 connection. The M-1 consumes 16 mA of current from the host unit's power supply.

In the majority of installations, the host unit will have ample spare current capacity to power one or more M-1s. However, installers should note that this may not be case in a very large system where many zones have remote input modules of various kinds. If there is any doubt about the power capability, please refer to the host unit's Installation and User Guide where full details of power supply ratings can be found.

Should you have any questions concerning the installation and connection of the M-1, please visit www.cloud.co.uk/resources, where you will find additional technical information.

www.cloud.co.uk



www.cloudusa.pro

MADE IN BRITAIN 