

# 24 GHz transceiver - BGT24LTR11

## Sense2GoL / Sense2GoL MAKE- XENSIV™ 24 GHz radar demo kit with BGT24LTR11 and XMC1302 32-bit ARM® Cortex™-M0 MCU for motion, speed, and direction of movement detection

Board version V1.2

### About this document

#### Scope and purpose

This application note describes the key features of Infineon's Sense2GoL module equipped with the 24 GHz transceiver chip BGT24LTR11 and the 32-bit ARM® Cortex™-M0 based XMC1302 microcontroller, and helps the user quickly get started with the demo board.

1. The application note describes the hardware configuration and specifications of the sensor module in detail
2. It also provides a guide to configure the hardware and implement simple radar applications with the firmware/software developed

Please note: The Sense2GoL and the Sense2GoL MAKE hardware are identical. They only differ by the pre-flashed firmware. More information at [www.infineon.com/makeradar](http://www.infineon.com/makeradar)

#### Intended audience

This document serves as a primer for users who want to get started with hardware design for motion, speed and direction of movement detection using Doppler radar technique at 24 GHz.

#### Related documents

Additional information can be found in the supplementary documentation provided with the Sense2GoL Kit in the Infineon Toolbox or from [www.infineon.com/24GHz](http://www.infineon.com/24GHz):

- 24 GHz Radar Tools and Development Environment User Manual

Table of contents

Table of contents

**About this document..... 1**

**Table of contents..... 2**

**List of figures ..... 3**

**List of tables ..... 4**

**1 Introduction ..... 5**

1.1 Key features.....5

**2 Getting started ..... 6**

2.1 Additional material .....8

**3 System specifications ..... 9**

**4 Hardware description .....10**

4.1 Overview .....10

4.2 Hardware features.....11

4.3 Block diagram.....11

4.4 Power supply .....12

4.5 RF front end .....13

4.5.1 Board stack-up .....13

4.5.2 BGT24LTR11 – 24 GHz transceiver MMIC .....14

4.5.3 Module transmitter and receiver sections .....14

4.5.4 Antennas.....15

4.5.5 Prescaler .....16

4.6 Analog baseband section .....16

4.7 Duty-cycle circuit for low-power operation .....18

4.8 Power consumption – duty cycle.....20

4.9 External pin header connectors.....21

4.10 Microcontroller unit – XMC1302.....21

4.11 Onboard debugger and UART connection .....22

4.12 User LEDs.....22

**5 Measurement results .....23**

**6 Frequency band and regulations .....24**

6.1 24 GHz regulations .....24

6.2 Regulations in Europe .....24

6.3 Regulations in the United States of America.....24

**7 Authors .....25**

**8 References .....26**

**Revision history.....27**

**List of figures**

**List of figures**

Figure 1	Steps 1 to 3 to get started with the Sense2GoL demo board .....	6
Figure 2	Steps 4 to 6 to get started with the Sense2GoL demo board .....	7
Figure 3	Steps 7 to 9 to get started with the Sense2GoL demo board .....	8
Figure 4	Sense2GoL board with main components and dimensions.....	10
Figure 5	Block diagram – Sense2GoL demo board .....	12
Figure 6	Block diagram – power supply concept .....	12
Figure 7	RF front-end overview (top) .....	13
Figure 8	PCB cross-section.....	13
Figure 9	Block diagram – BGT24LTR11 .....	14
Figure 10	Transmitter and receiver sections schematic .....	15
Figure 11	2D radiation pattern for array antennas (simulated).....	15
Figure 12	2D radiation pattern at 24.047 GHz (antenna chamber).....	16
Figure 13	Divider output schematic.....	16
Figure 14	Baseband amplifier chain on PCB .....	17
Figure 15	Analog baseband frequency response .....	18
Figure 16	PWM1 (from XMC1302) controls the PMOS switch to turn the BGT24LTR11 on/off .....	19
Figure 17	Duty-cycle operation circuitry .....	19
Figure 18	PWM1, IF_Q and IF_I signals for on-time = 400 ms and frame interval time = 3000 ms.....	20
Figure 19	Sense2GoL external header pin overview .....	21
Figure 20	Recommended installation options for the J-Link driver.....	22
Figure 21	Speed measurements (radar vs. Doppler simulator).....	23



**List of tables**

**List of tables**

Table 1	Sense2GoL module performance specifications .....	9
Table 2	LDO connections – schematics and PCB .....	13
Table 3	Baseband amplifiers to MCU pin connections .....	17
Table 4	Baseband amplifier components and settings .....	17
Table 5	Doppler shift frequencies for different speeds using 24 GHz radar.....	18
Table 6	Power consumption measurements and settings – BGT24LTR11 duty cycle.....	20
Table 7	External headers – pin description .....	21
Table 8	XMC4200 pins used for debugging and UART communication .....	22
Table 9	User LEDs pin assignment.....	22

## Introduction

# 1 Introduction

The Sense2GoL Kit is a demonstration platform for Infineon's silicon-germanium (SiGe) based 24 GHz BGT24LTR11 radar chipset. The board is capable of detecting Doppler-based motion, speed and direction of movement (approaching or retreating). These features of the board make it suitable for various applications such as indoor/outdoor lighting, intelligent switches, automatic door openers, etc.

The Sense2GoL board consists of the following key components:

- BGT24LTR11 – highly integrated 24 GHz transceiver IC with one transmitter (TX) and one receiver (RX)
- XMC1302 – 32-bit ARM® Cortex™-M0 based microcontroller for signal processing
- XMC4200 onboard debugger – licensed firmware for Serial Wire Debug (SWD) and UART to USB communication

The Continuous Wave (CW) or Doppler radar technique is used on the board. With CW/Doppler technique, the principle of the Doppler effect is used. The radar transmits a constant frequency signal continuously and receives the echo signal from the moving target. The change in phase between the transmitted and received signal is used to calculate the target's velocity.

The module provides a complete radar system evaluation platform including demonstration software and a basic Graphical User Interface (GUI), which can be used to display and analyze acquired data in time and frequency domain. An onboard breakable debugger with licensed firmware from SEGGER enables easy debugging over USB. Infineon's powerful, free-of-charge toolchain DAVE™ can be used for programming the XMC1302 microcontroller. The board also features integrated micro-strip patch antennas on the PCB with design data, thereby eliminating antenna design complexity at the user end.

This application note describes the key features and hardware configuration of the Sense2GoL module in detail.

## 1.1 Key features

The primary features of the Sense2GoL board are:

- Detection of motion, speed and direction of movement (approaching or retreating)
- High detection sensitivity
- Measurement of speed of single human target (1 to 15 m)
- Very small form factor: 2.5 x 5 cm
- Operational in different weather conditions such as rain, fog, etc.
- Can be hidden in the end application, as it detects through non-metallic materials
- Dual analog amplifier stages for RX channel
- Integrated multiple elements: patch antennas with 10 dBi gain and 29 x 80 degrees Field of View (FoV)
- Onboard PMOS switch for duty-cycle operation and low power consumption

*Note: The platform serves as a demonstrator platform with the software to perform simple motion sensing and ranging. The test data in this document show typical performance of Infineon-produced platforms.*

Getting started

## 2 Getting started

This section provides a step-by-step quick process to get started with the Sense2GoL board. Some of the steps are optional for going deeper into the analysis of the board, the firmware and the extracted signals.







STEP 1	STEP 2	STEP 3
<p><b>Box contents</b></p> <ul style="list-style-type: none"> <li>• Programmed Sense2GoL board</li> <li>• Micro-USB cable</li> <li>• Foldable corner reflector</li> </ul> 	<p><b>Infineon Toolbox</b></p> <ul style="list-style-type: none"> <li>• Go to: <a href="http://www.infineon.com/Toolbox">www.infineon.com/Toolbox</a></li> <li>• Click on the “Download now” button.</li> </ul>  <ul style="list-style-type: none"> <li>• Run the “infineon-toolbox-launcher-web-installer-win-x86-latest.exe” file.</li> </ul>  <ul style="list-style-type: none"> <li>• “Accept” the license agreement.</li> <li>• Finish installation. Create a desktop shortcut.</li> </ul> 	<p><b>Install Sense2GoL Kit</b></p> <ul style="list-style-type: none"> <li>• Open “Infineon Toolbox”.</li> <li>• Click on the “Manage tools” tab.</li> <li>• Search for “Sense2GoL Kit”.</li> </ul>  <ul style="list-style-type: none"> <li>• Click on “Install”.</li> </ul>  <ul style="list-style-type: none"> <li>• “Accept” the license agreement.</li> <li>• Finish installation.</li> </ul> 

Figure 1 Steps 1 to 3 to get started with the Sense2GoL demo board

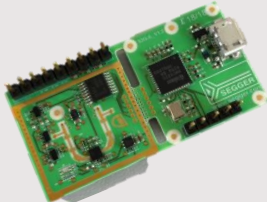
Getting started

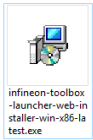

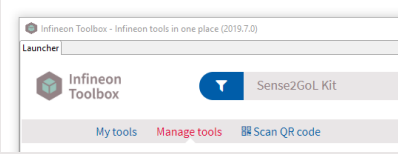
STEP 4	STEP 5	STEP 6 Optional
<p><b>Download SW/HW package</b></p> <ul style="list-style-type: none"> <li>Open “<b>Infineon Toolbox</b>”.</li> <li>Click on “<b>Sense2GoL Kit</b>”.</li> <li>Download the package from the “<b>Software &amp; Documentation</b>” left tab.</li> <li>Save the set-up file and run it.</li> </ul>  <p><b>S2GL-HW-SW.exe</b></p> <ul style="list-style-type: none"> <li>Browse to the preferred location to store the files.</li> </ul> 	<p><b>Connect board</b></p> <ul style="list-style-type: none"> <li>Insert the micro-USB cable into the Sense2Go board</li> </ul>  <ul style="list-style-type: none"> <li>Insert the USB connector into the PC USB port.</li> </ul>  <p><b>⚠ If the device driver is not recognized:</b></p> <p>Right-click on “My Computer”          ▶ Manage ▶ Device Manager ▶ Other devices ▶ Right-click on “Unknown device” ▶ Update Driver Software ▶ Browse ▶ Firmware_Software ▶ XMC_Serial_Driver.</p>	<p><b>Firmware (FW) update</b></p> <ul style="list-style-type: none"> <li>Download and install SEGGER J-Link USB drivers for Windows:  <a href="http://www.segger.com/download/s/jlink/#J-LinkSoftwareAndDocumentationPack">www.segger.com/download/s/jlink/#J-LinkSoftwareAndDocumentationPack</a></li> <li>Connect the board as in <b>STEP 5</b>.</li> <li>Open <b>Infineon Toolbox ▶ XMC Flasher</b>.</li> </ul>  <ul style="list-style-type: none"> <li>Check that debugger type is “<b>SEGGER</b>”, otherwise go to: “<b>Configurations</b>” ▶ “<b>Setup</b>”, then set it to “<b>SEGGER</b>”.</li> <li>Click on “<b>Connect</b>” ▶ <b>XMC1302-0016</b>.</li> <li>Click on “<b>Select file</b>” ▶ Browse to <b>Firmware_Software ▶ Binary ▶ .hex file ▶ Program</b>.</li> </ul>

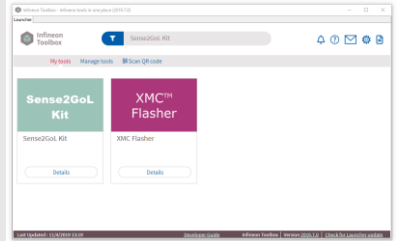
Figure 2 Steps 4 to 6 to get started with the Sense2GoL demo board

Getting started

STEP 7	STEP 8	STEP 9
Optional		Optional
<p><b>View and edit source code</b></p> <ul style="list-style-type: none"> <li>Download and install the DAVE™ IDE tool: <a href="https://infineoncommunity.com/dave-download_ID645">https://infineoncommunity.com/dave-download_ID645</a></li> <li>Go to <b>Firmware_Software ▶ DAVE project</b>.</li> <li>Run DAVE™ IDE.</li> <li>Import DAVE™ projects and debug.</li> </ul> 	<p><b>Micrium GUI</b></p> <ul style="list-style-type: none"> <li>Connect the board as in <b>STEP 5</b>.</li> <li>Download and install the μC/Probe™ XMC™ tool: <a href="https://infineoncommunity.com/uC-Probe-XMC-software-download_ID712">https://infineoncommunity.com/uC-Probe-XMC-software-download_ID712</a></li> <li>Go to: <b>Firmware_Software ▶ GUI ▶ S2GL_GUI.wsp.x</b>.</li> </ul>  <ul style="list-style-type: none"> <li>Click on the <b>“Run”</b> button at the top left corner.</li> </ul>  <ul style="list-style-type: none"> <li>Click on <b>“Start”</b> to see real-time data on your screen.</li> </ul>	<p><b>MATLAB interface</b></p> <ul style="list-style-type: none"> <li>Go to: <b>Firmware_Software ▶ Communication Library ▶ ComLib_Matlab_Interface ▶ matlab ▶ RadarSystemExamples ▶ GettingStarted</b>. Copy the path.</li> <li>Open MATLAB. Paste the path in the top tab. <b>“extract_raw_data.m”</b> file will show up on the left tab.</li> <li>Connect the board as in <b>STEP 5</b>.</li> <li>Click on <b>“Run”</b> to see raw data.</li> </ul>  <p><b>➤ Make sure XMC flasher is closed or disconnected while collecting raw data</b></p>

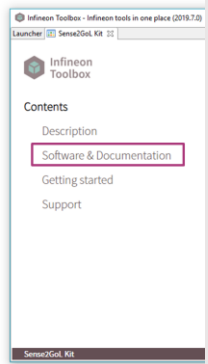
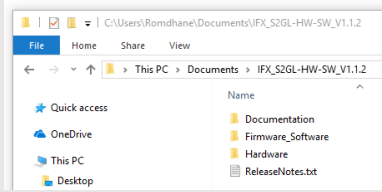
Figure 3 Steps 7 to 9 to get started with the Sense2GoL demo board

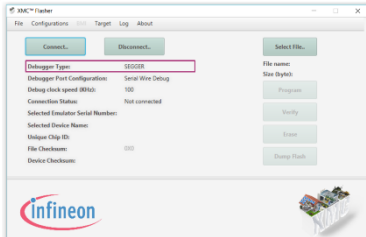
2.1 Additional material

The board comes with additional documentation for customer support. These documents can be found in the folders downloaded through Step 4 in Figure 2. They are:

- Altium project
- DAVE™ project and binary files
- Schematics
- Bill of Materials (BOM)
- Production data

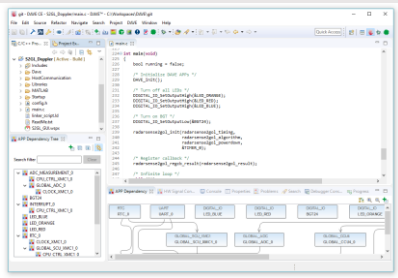
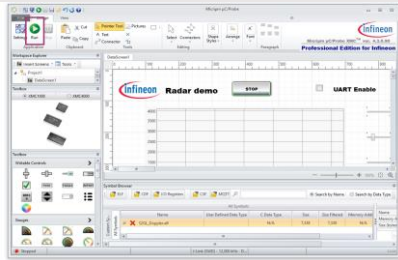
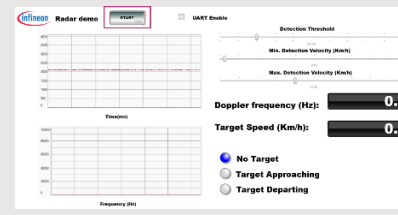
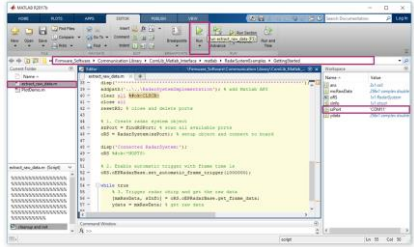

System specifications

### 3 System specifications

Table 1 gives the specifications of the Sense2GoL module.

**Table 1 Sense2GoL module performance specifications**

Parameter	Unit	Min.	Typ.	Max.	Comments
<b>System performance</b>					
Minimum speed	km/h		0.5		
Maximum speed	km/h		30		
Maximum distance	m		15		Human target
<b>Power supply</b>					
Supply voltage	V	3.3	5	5.5	
Supply current	mA		140		All blocks on (no duty cycle)
<b>Transmitter characteristics</b>					
Transmitter frequency	GHz		24.125		
Effective Isotropic Radiated Power (EIRP)	dBm		+14		<b>Conditions:</b> BGT P <sub>OUT</sub> : +6 dBm Loss (TX <sub>OUT</sub> to ant. input = 2 dB) Simulated ant. gain = +10 dBi
<b>Receiver characteristics</b>					
Receiver frequency	GHz		24.125		
IF conversion gain – (stage 1 + stage 2)	dB		52		Default setting of the sensor module when delivered
-3 dB bandwidth – (stage 1 + stage 2)	Hz	23		1.8k	Default setting of the sensor module when delivered
<b>Antenna characteristics (simulated)</b>					
Antenna type			1 x 4		
Horizontal – 3 dB beamwidth	Degrees		80		
Elevation – 3 dB beamwidth	Degrees		29		
Horizontal sidelobe level suppression	dB	13			
Vertical sidelobe level suppression	dB	13			

*Note: The above specifications are indicative values based on typical datasheet parameters of BGT24LTR11 and simulation of several other parameters (antenna characteristics and baseband section) and can vary from module to module. The numbers above are not guaranteed indicators for module performance for all operating conditions.*

Hardware description

## 4 Hardware description

### 4.1 Overview

The Sense2GoL module contains a radar main board and a breakable debugger board, as shown in Figure 4. The radar main board contains four important sections:

- RF part – consists of the Infineon 24 GHz radar MMIC – BGT24LTR11 and micro-strip patch antennas for the TX and RX sections
- Analog amplifier part – provides the interface between the RF and the digital parts of the board
- Digital part – consists of XMC1302, 32-bit ARM® Cortex™-M0 microcontroller from Infineon to sample and process the analog data from the radar front end

The board demonstrates the features of the BGT24LTR11 RF front-end chip and gives the user a complete “plug and play” radar solution. It makes it possible to quickly gather sampled radar data that can be used to develop radar signal processing algorithms on a PC or implement target detection algorithms directly on the microcontroller using DAVE™.

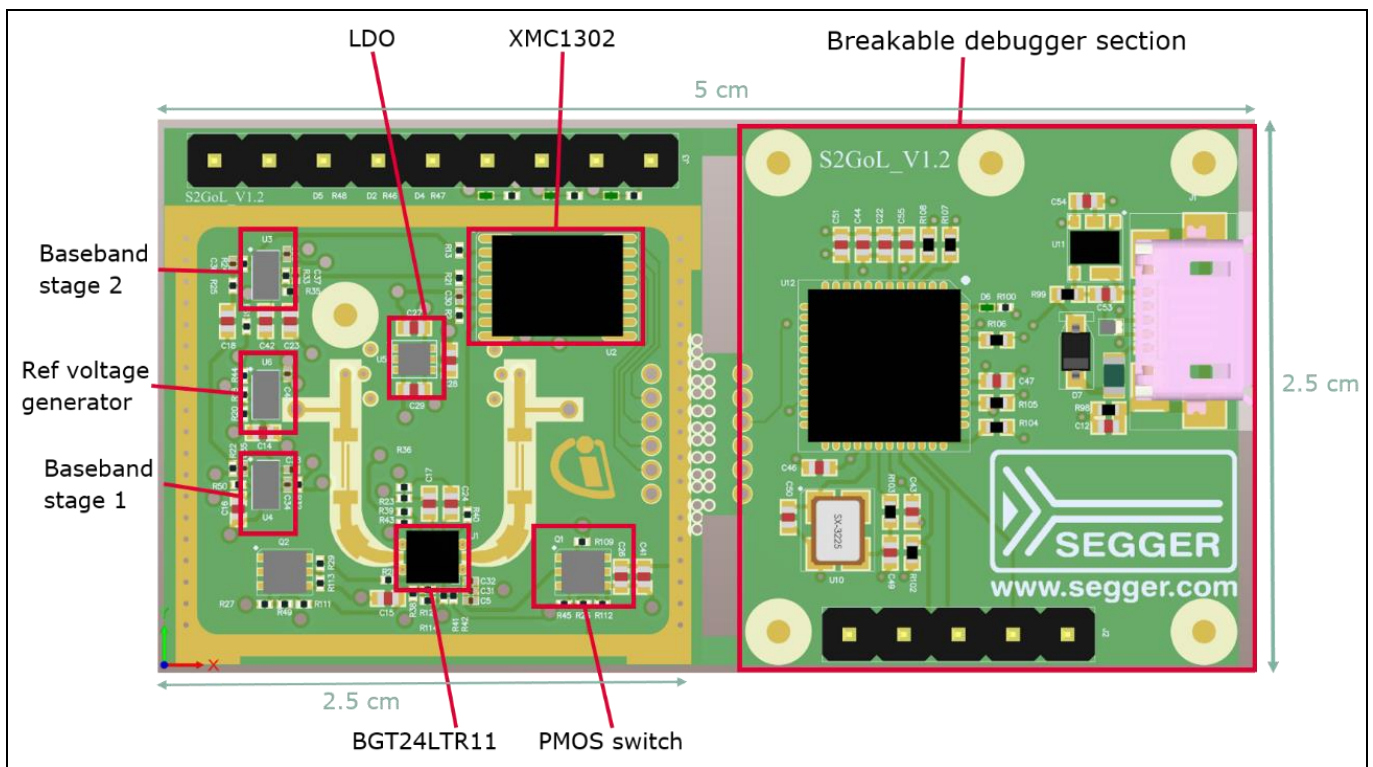

Figure 4 Sense2GoL board with main components and dimensions

## Hardware description

### 4.2 Hardware features

The Sense2GoL demo board has the following features:

- BGT24LTR11 24 GHz RF front-end chip with 1 TX and 1 RX with the following specifications:
  - Built-in temperature compensation circuit Proportional to Absolute Temperature (PTAT) for Voltage Controlled Oscillator (VCO) stabilization
  - Low power consumption: 165 mW (Doppler radar without dividers turned on)
  - Switchable prescalars with 1.5 GHz and 3 MHz output
- XMC1302 Cortex-M0 microcontroller for sampling and signal processing of the analog signals with the following features:
  - 32 MHz CPU frequency, 16 kB Flash and 16 kB RAM size
  - One Capture and Compare Unit (CCU4) for use as a general-purpose timer
  - One Capture and Compare Unit (CCU8) for motor control and power conversion
  - One 12-bit ADC, 16 channels
  - Two Universal Serial Interface Channels (USICs), usable as UART, double-SPI, quad-SPI, I<sup>2</sup>C, I<sup>2</sup>S and LIN interfaces
- Onboard breakable debugger with UART communication
- Dual analog amplifier stage for RX channel
- Micro-strip patch antennas with 10 dBi gain (simulated) and 29 x 80 degrees FoV
- Onboard PMOS switch for duty-cycle operation of BGT24LTR11
- Power supply:
  - Via micro-USB connector
  - Via external power supply (5 V maximum)

### 4.3 Block diagram

Figure 5 shows the block diagram of the demo board. The board is split into a RF unit and a breakable debugger unit for programming. The RF unit consists of the highly integrated 24 GHz transceiver IC BGT24LTR11 with 1 TX and 1 RX.

A built-in voltage source delivers a VCO tuning voltage, which is PTAT. When connected to the VCO tuning pin it compensates for the inherent frequency drift of the VCO over-temperature, thus stabilizing the VCO within the ISM band and eliminating the need for a PLL/microcontroller.

The baseband section provides the required gain to the IF signals from the MMIC. The outputs of the baseband section are connected with ADC inputs of the XMC1302. The XMC1302 MCU samples the two IF channels of the transceiver chipset and communicates via USB interface to a connected PC. A provided PC application GUI (Windows-based) can be used to display and analyze acquired data in time and frequency domain. The GUI allows for the extraction of the radar time domain signals, enabling advanced debugging and algorithm development.

**Hardware description**

The module is powered via the micro-USB plug, and a low-noise voltage regulator is used to provide a regulated power supply to the different building blocks. The BGT24LTR11 MMIC is supplied over a PMOS, which enables operation of the sensor in a duty-cycle mode. The breakable onboard debugger comes preloaded with licensed firmware for debugging and communicating with the main radar MCU via the UART pins. Pin headers on the PCB allow for interfacing the sensor module with an external processor.

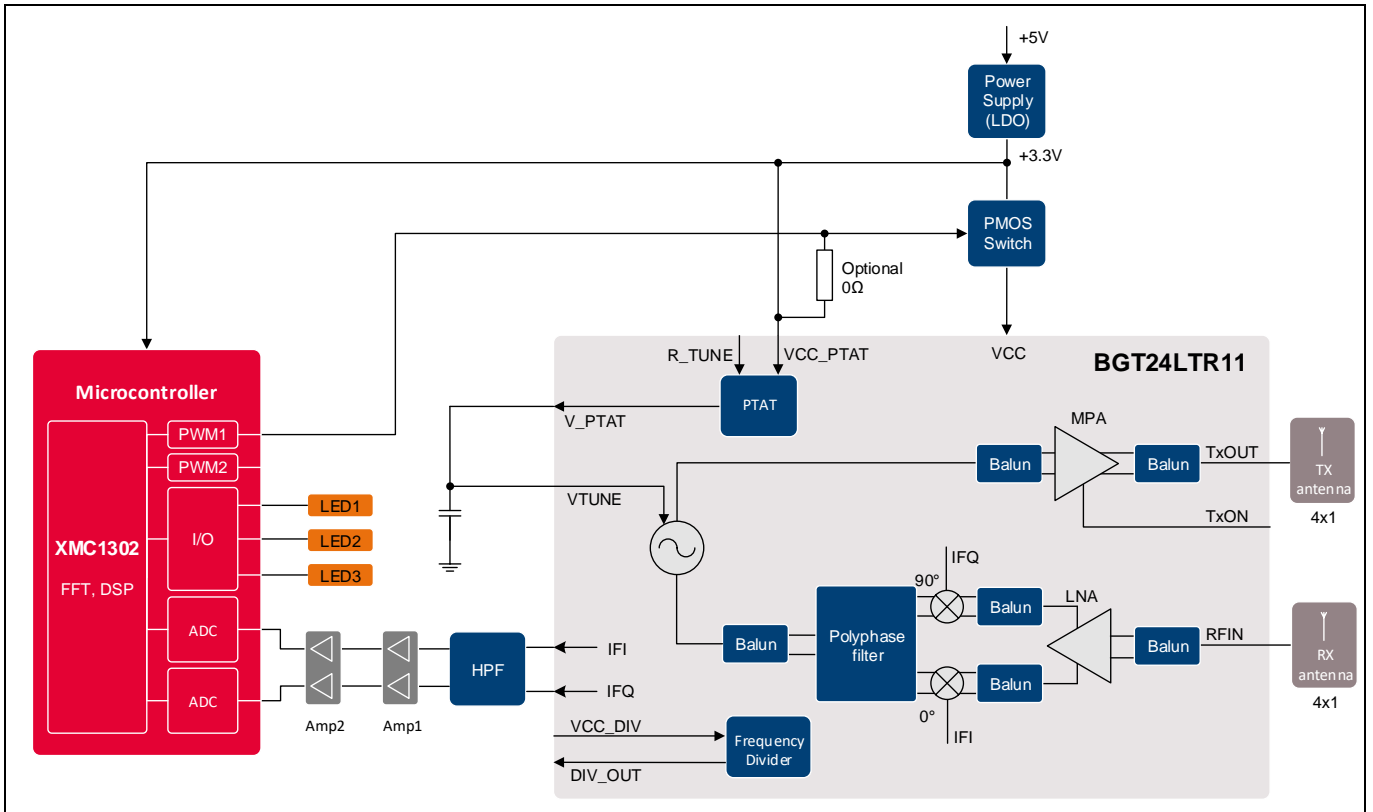

**Figure 5** Block diagram – Sense2GoL demo board

**4.4 Power supply**

Figure 6 shows the power supply concept used on the module. The board is powered via micro-USB connector when used with a PC. The power can also be supplied via an external DC input pin (5 V maximum). A dual LDO is used to supply the RF/op-amp and MCU separately.

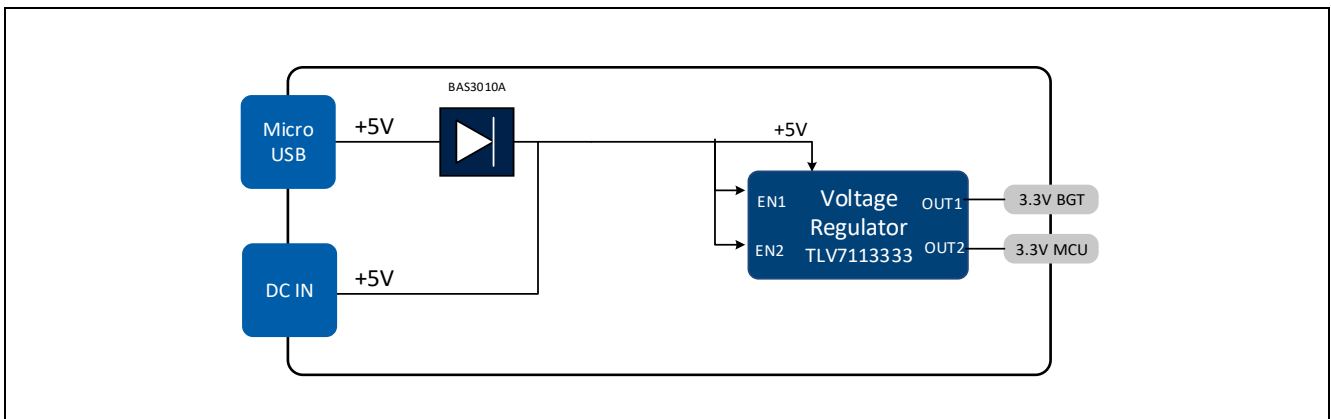

**Figure 6** Block diagram – power supply concept

Hardware description

Table 2 LDO connections – schematics and PCB

LDO	Supply net	Components powered
TLV113333 (U5)	Pin OUT1 – 3V3	BGT24LTR11 (U1), OPA2376 (U3, U4, U6)
TLV113333 (U5)	Pin OUT2 – VDD_3V3	XMC1302 (U2), LED (D2, D4, D5)

4.5 RF front end

Figure 7 shows the top view of the RF front end. The RF front end can be shielded with a cover and absorbent material to get the best RF performance.

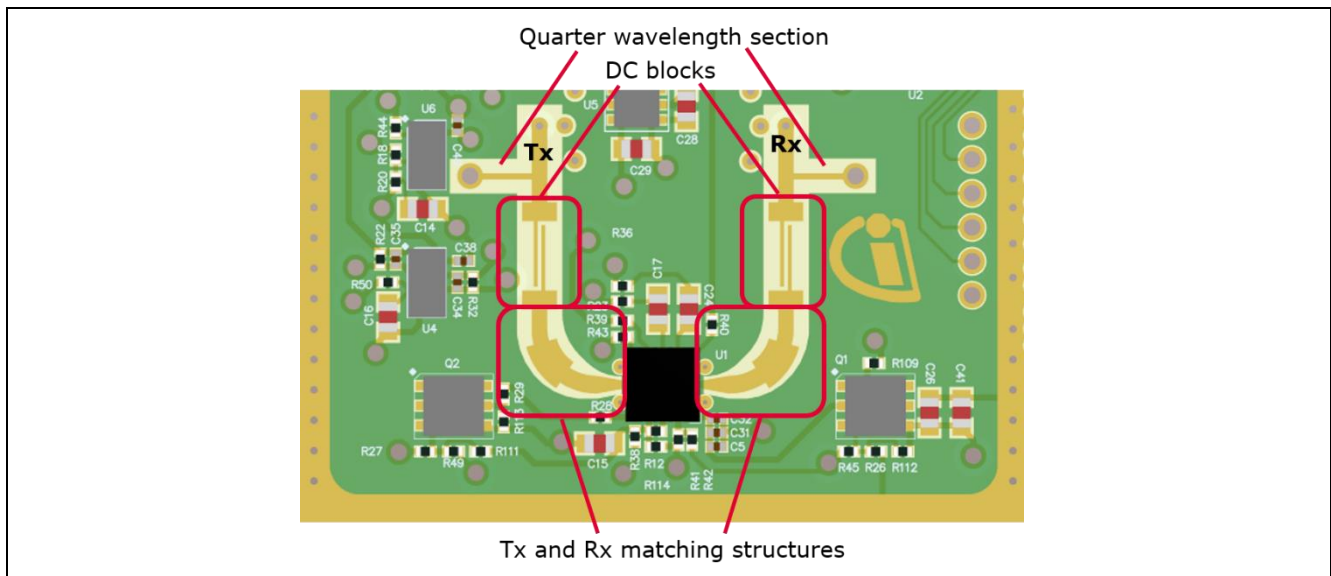

Figure 7 RF front-end overview (top)

4.5.1 Board stack-up

It is necessary to use a defined board layer stack-up for proper functioning of the RF part. All the micro-strip RF parts must be calculated according to the stack-up used. The cross-sectional view of the PCB is shown in Figure 8. The module uses six-layer stack up with a symmetrical RO-4350B core. The matching structures for the transmitter and receiver part are designed based on this stack-up.

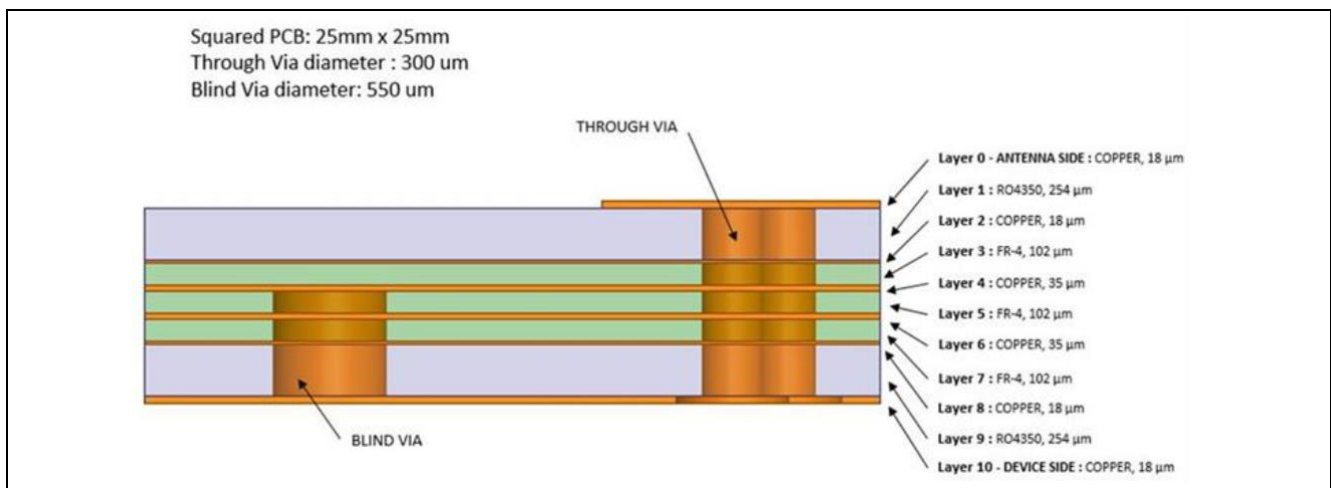

Figure 8 PCB cross-section

**Hardware description**

The most important part for the RF micro-strip components is the top and bottom RO-4350B, 0.254 mm-thick core. On the top layer (layer 1) are the micro-strip structures, and layer 2 is the RF ground for the micro-strip components used on the top layer. Layer 3 and layer 4 are used for routing various signals. On the bottom layer (layer 6) are the micro-strip patch antennas, and layer 5 is the RF ground for the micro-strip patch antennas. The substrate thickness for the other layers has been chosen taking into account the blind-via diameters used on the PCB, and this can vary depending on the PCB manufacturing technology (aspect ratio). From simulations it was observed that such minor variation of the thickness of these FR4 substrates has a very low impact on the RF performance.

**4.5.2 BGT24LTR11 – 24 GHz transceiver MMIC**

The heart of the sensor module is the highly integrated BGT24LTR11 24 GHz transceiver IC. Figure 9 shows the detailed block diagram of the MMIC.

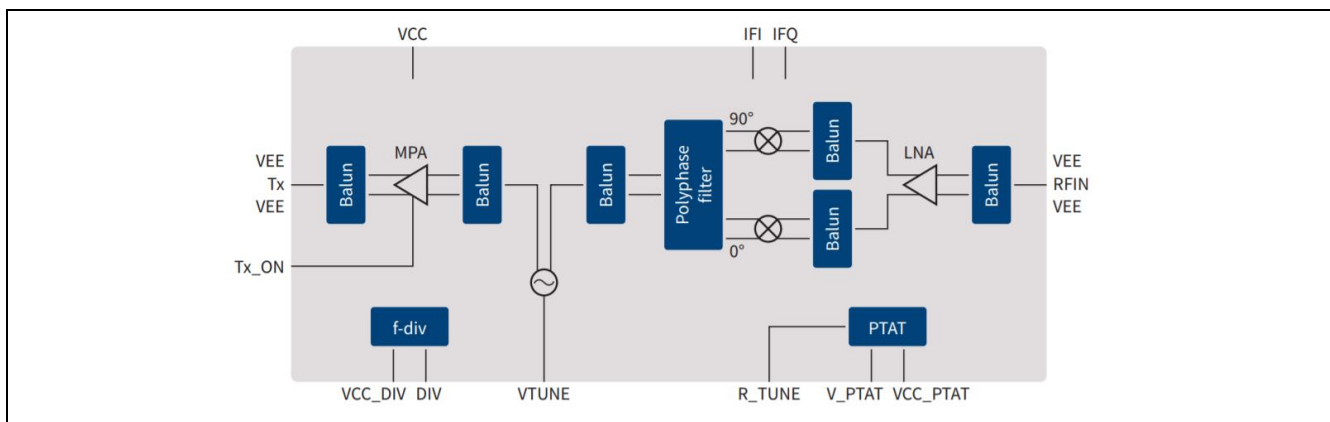

**Figure 9 Block diagram – BGT24LTR11**

BGT24LTR11 is a SiGe radar MMIC for signal generation and reception, operating in the 24.000 GHz to 24.250 GHz ISM band. It is based on a 24 GHz fundamental VCO.

The device was designed with Doppler-radar applications in mind – as it is capable of keeping the transmit signal inside the ISM band without any external PLL.

A built-in voltage source delivers a VCO tuning voltage, which is PTAT. When connected to the VCO tuning pin it compensates for the inherent frequency drift of the VCO over-temperature, thus stabilizing the VCO within the ISM band and eliminating the need for a PLL/microcontroller. An integrated 1:16 frequency divider also allows for external Phase Lock Loop (PLL) VCO frequency stabilization.

The receiver section uses a Low-Noise Amplifier (LNA) in front of a quadrature homodyne down-conversion mixer in order to provide excellent receiver sensitivity. Derived from the internal VCO signal, a RC Polyphase Filter (PPF) generates quadrature LO signals for the quadrature mixer. I/Q IF outputs are available through single-ended terminals.

**4.5.3 Module transmitter and receiver sections**

The transmitter and receiver inputs of the BGT24LTR11 are single-ended. The TX output and RX input are connected over a matching structure, a DC block and a feed-through via to the antennas on the other side of the board. Figure 10 shows the schematic of the transmitter and receiver sections. There are DC shorts before the feed-through vias for enhanced ESD protection.

For more information on the matching structure implementation, please refer to Section 3 of [AN472](#).



Hardware description

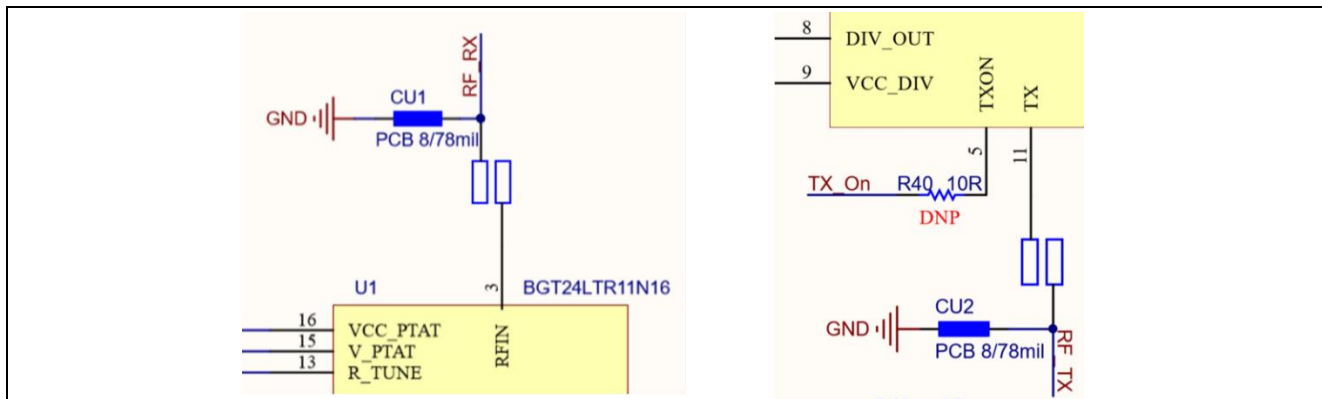

Figure 10 Transmitter and receiver sections schematic

### 4.5.4 Antennas

Sense2GoL features a 4 x 1 antenna array for the transceiver and receiver sections. The antenna has a measured gain of 10 dBi (simulated) and an opening angle of 29 x 80 degrees. Figure 11 and Figure 12 show the simulated and measured radiation patterns.

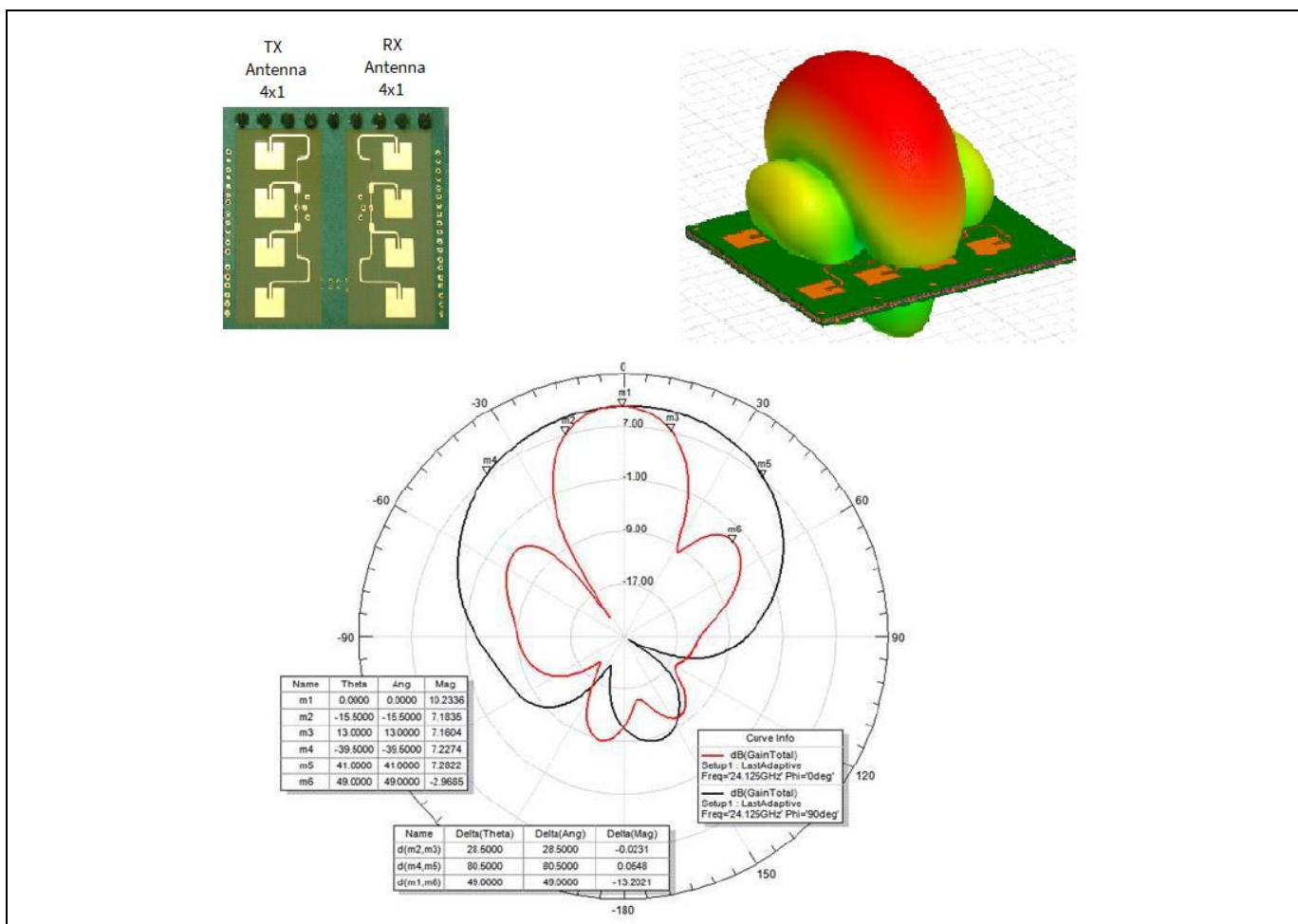

Figure 11 2D radiation pattern for array antennas (simulated)

Hardware description

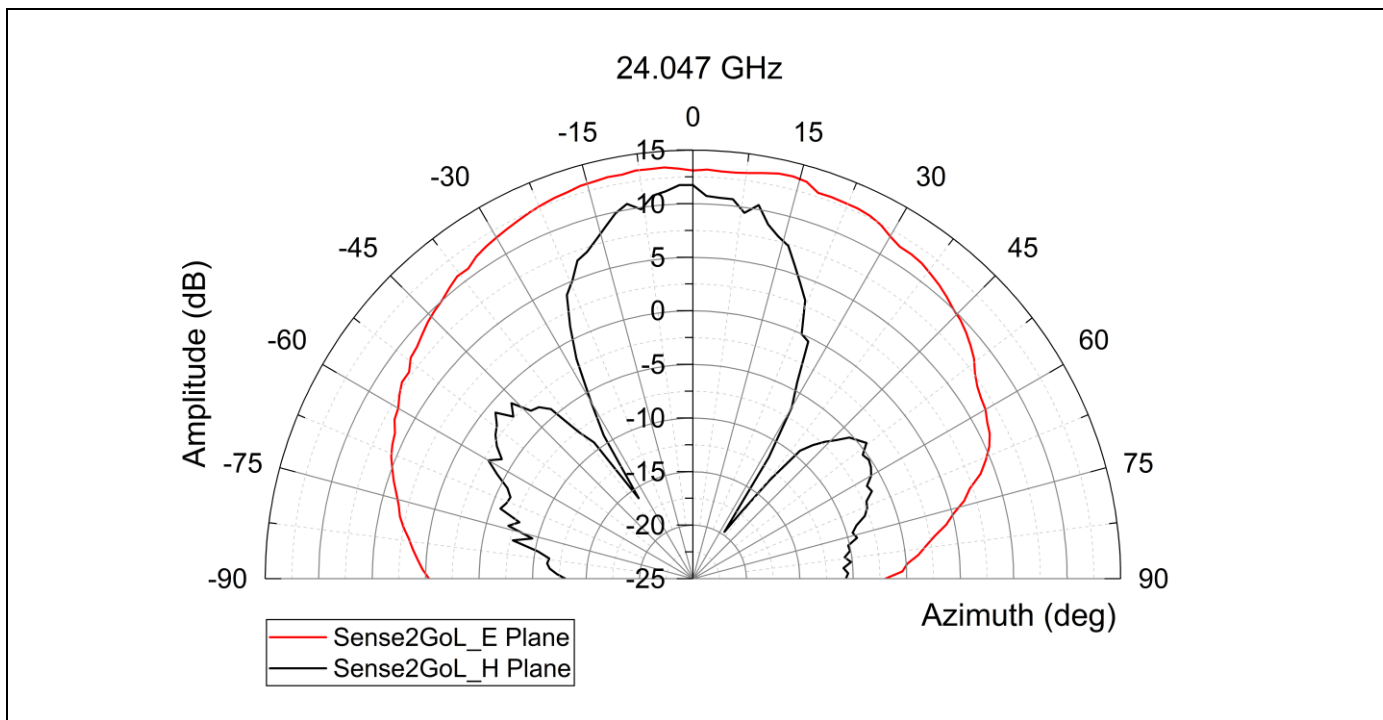

Figure 12 2D radiation pattern at 24.047 GHz (antenna chamber)

### 4.5.5 Prescaler

BGT24LTR11’s frequency divider has two divider ratios – divide by 16 and divide by 8182 – which result in output frequencies of 1.5 GHz and 3 MHz respectively. The divider’s output can be monitored on pin 1 of the external header (J3) by soldering the R39 0 Ω resistor at the DIVOUT (pin 8) of the MMIC.

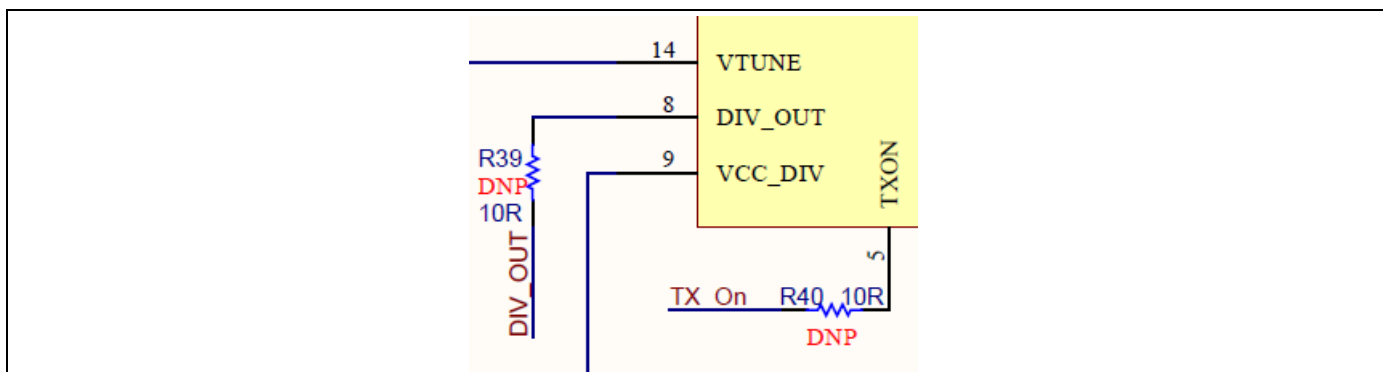

Figure 13 Divider output schematic

### 4.6 Analog baseband section

The BGT24LTR11 provides both in-phase and quadrature-phase Intermediate Frequency (IF) signals from its receiver. Depending on the target in front of the radar antennas, the analog output signal from the BGT24LTR11 chipset can be very low in amplitude (µV to mV range). To process these low-amplitude signals it is necessary to amplify the IF signals that come out of the RF front end with analog amplifiers.

Each IF path comprises two stages of dual-channel low-noise operational amplifiers (U4 and U3). An additional op-amp (U6) is used to generate the reference voltage of 1.65 V for the baseband section. Figure 14 shows the detailed schematic of the baseband amplifier section.



Hardware description

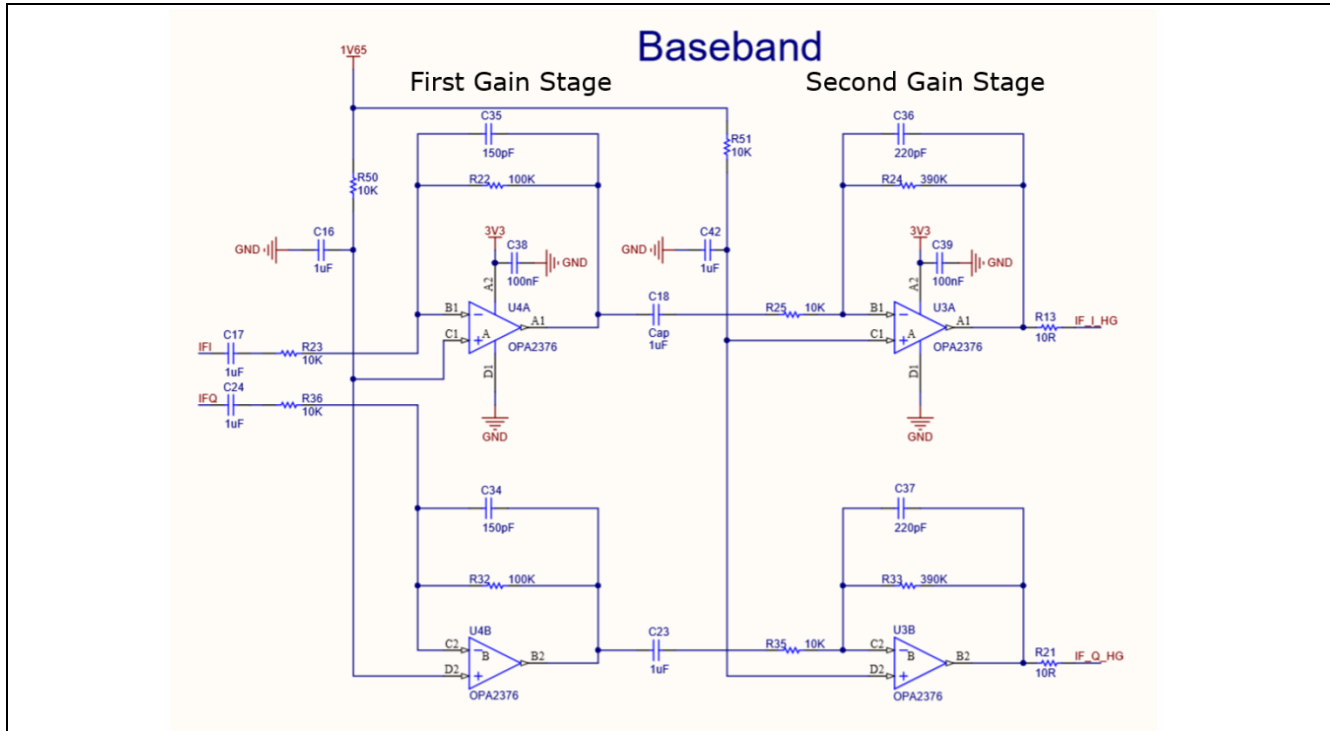

Figure 14 Baseband amplifier chain on PCB

The outputs of the second baseband stage (IF\_I\_HG and IF\_Q\_HG) are connected to the ADCs of the MCU for further processing. Table 3 lists the MCU pins assigned to the IFI and IFQ high gain signals. Use the graphical pin select tool in the DAVE™ software to select the appropriate pins for signal processing.

Table 3 Baseband amplifiers to MCU pin connections

XMC1302 – TSSOP-16 – port pin	Pin function
P2.9	IFI – high gain
P2.11	IFQ – high gain

The gain and bandwidth of the IF stages are fixed and can be manually configured by the user by changing the resistor and capacitor values specified in Table 4.

Table 4 Baseband amplifier components and settings

IF stage	Designator	Gain	Configurable components – I section	Configurable components – Q section
Stage 1 (low gain)	U4	20 dB	C17, R23, R22, C35	C24, R36, C34, R32
Stage 1 + stage 2 (high gain)	U4 + U3	52 dB	All components as mentioned for stage 1 + C18, R25, C36, R24	All components as mentioned for stage 1 + C23, R35, C37, R33

Figure 15 shows the frequency response of the low and high gain stages.

Hardware description

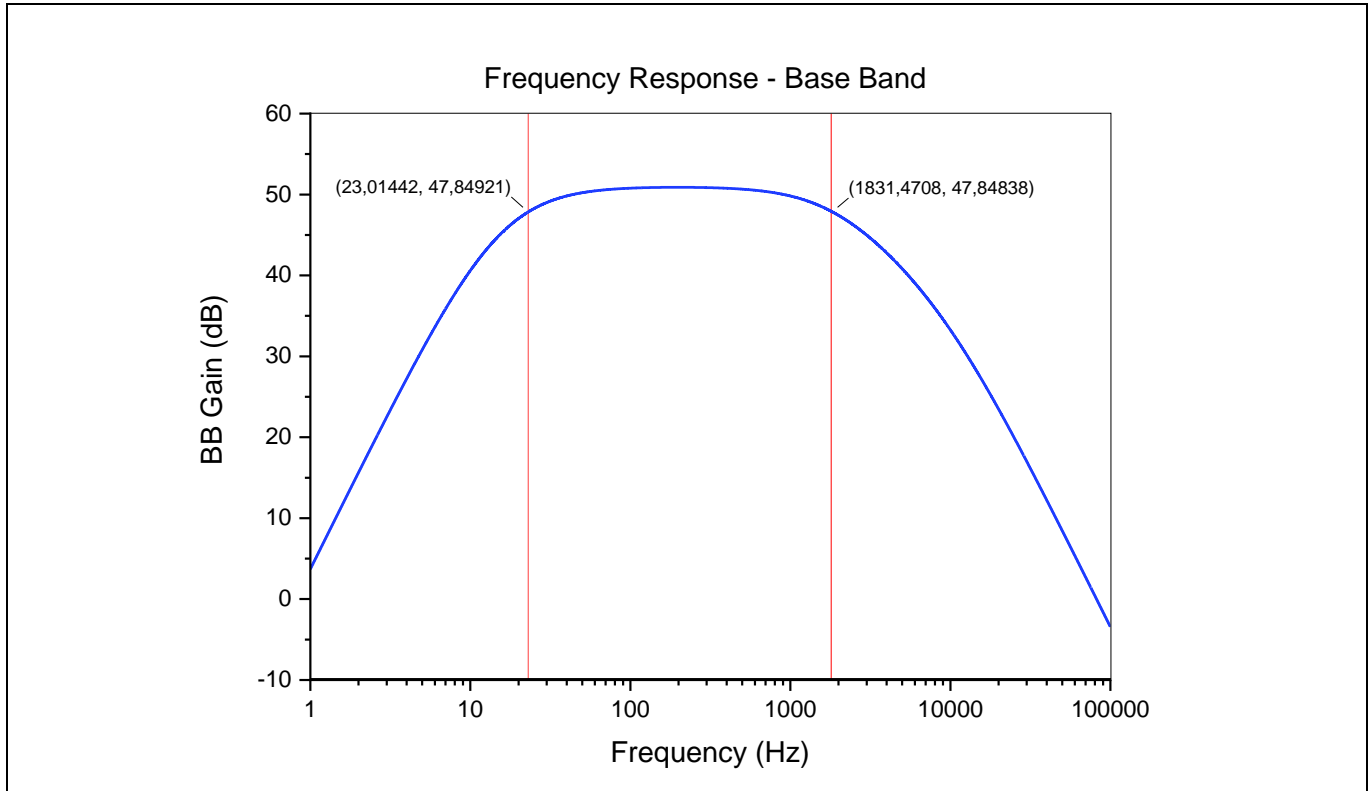

**Figure 15** Analog baseband frequency response

The baseband section should be configured accordingly to provide sufficient gain at these frequencies. The cut-off frequencies of the baseband section are 23 Hz to 1.8 kHz.

The Doppler frequency  $f_{Doppler}$  is calculated using the following formula:

$$f_{Doppler}(Hz) = \frac{2v}{\lambda}$$

Where  $v$  = speed of the target (m/s)  
 $\lambda$  = wavelength (m)

Table 5 shows the calculated Doppler frequency values for different target speeds for the 24 GHz radar module.

**Table 5** Doppler shift frequencies for different speeds using 24 GHz radar

Speed (km/h)	0.5	1	5	10	15	20	25	30	35
Doppler shift (Hz)	22	44	223	445	668	891	1114	1337	1559

**4.7 Duty-cycle circuit for low-power operation**

The board offers the possibility to operate the BGT24LTR11 in a duty-cycle mode. This is performed by enabling/disabling the PMOS switch (Q1) over the pin P0.6 (PWM1) of the XMC1302 as shown in Figure 16. Toggling this pin allows switching on/off the power supply ( $V_{CC}$ ) to the BGT24LTR11 MMIC over the PMOS. This helps to reduce the power consumption.

Hardware description

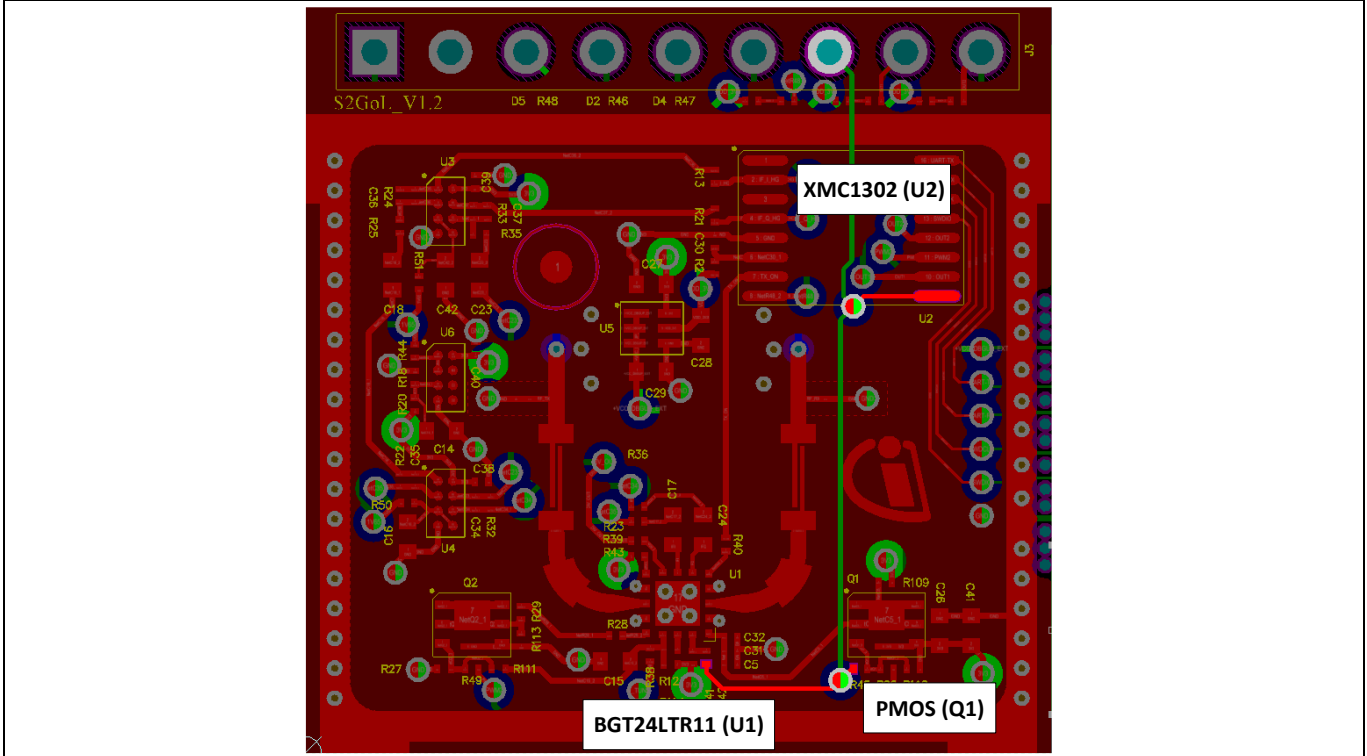

Figure 16 PWM1 (from XMC1302) controls the PMOS switch to turn the BGT24LTR11 on/off

The R109 resistor bypasses the PMOS switch. In order to control the PMOS switch using the PWM1 signal to turn the BGLTR11 on/off it is necessary to make sure that R109 is not assembled on the board.

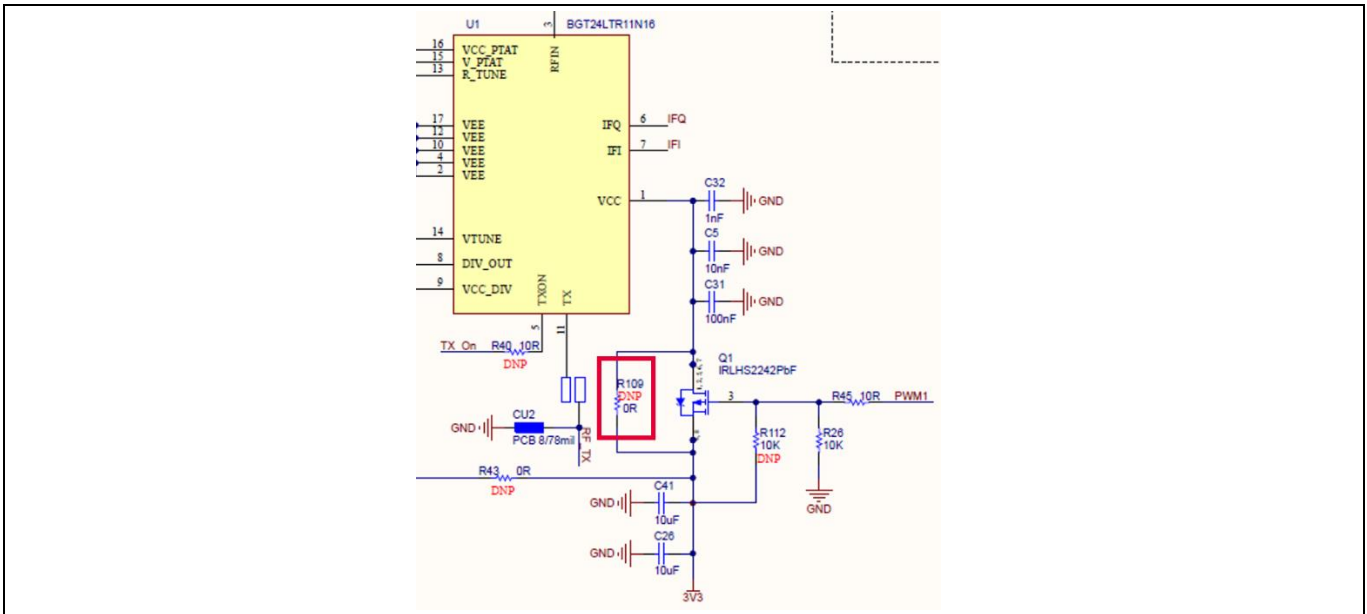

Figure 17 Duty-cycle operation circuitry

The PWM1 signal is active-low and has a pull-down resistor in place. The duration for which the PWM1 signal is high/low determines the duty-cycle percentage and hence the amount of power consumption.

Hardware description

### 4.8 Power consumption – duty cycle

The PWM1 signal is toggled to turn the BGT24LTR11 on/off. The settings in the DAVE™ project control the on/off time of the PWM1 signal.

$$\text{Duty cycle \%} = \frac{\text{ON time}}{\text{Total frame interval time}} \times 100$$

Table 6 shows the measurement data for different duty-cycling proportions and the required settings.

**Table 6 Power consumption measurements and settings – BGT24LTR11 duty cycle**

Frame interval (ms)	Duty cycle (%)	Op-amps – U3, U4, U6 (mA)	BGT24LTR11 – U1 (mA)	Total	
				I (mA)	P (mW)
1000	40	5	18.6	23.6	77.9
2000	20	5	9.3	14.3	47.2
3000	13	5	6.2	11.2	36.9
4000	10	5	4.7	9.7	31.8
5000	8	5	3.7	8.7	28.8

*Note: Debugger section consumes 80 mA current and XMC1302 consumes 9.6 mA current at all times.*

As can be seen in Table 6, the power consumption reduced significantly when duty cycling is applied. However, since the op-amps are not duty-cycled, they take a big share of the power budget at lower duty-cycle percentages.



**Figure 18 PWM1, IF\_Q and IF\_I signals for on-time = 400 ms and frame interval time = 3000 ms**

Hardware description

### 4.9 External pin header connectors

The Sense2GoL module has the provision to connect a nine-pin header on the edge of the board, as shown in Figure 19. Table 7 describes the pins.

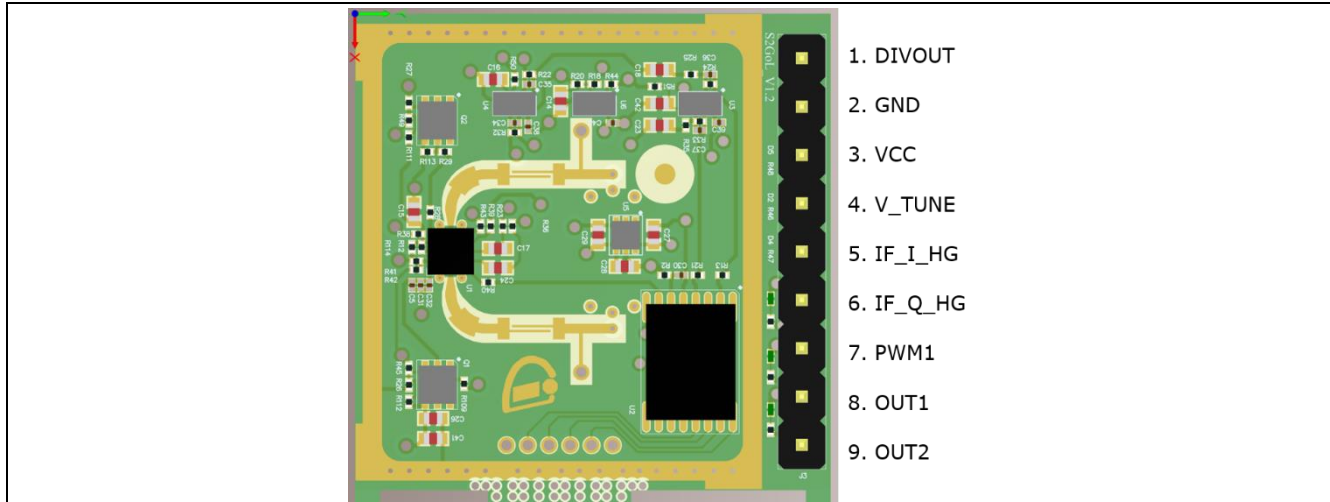

Figure 19 Sense2GoL external header pin overview

Table 7 External headers – pin description

Pin number	Signal name	Pin description
1	DIV_OUT	Frequency divider output from the BGT24LTR11
2	GND	Ground
3	VCC_5V_EXT	External +5.0 V input power supply pin (maximum = 5.5 V)
4	VTUNE	VCO frequency tuning voltage
5	IFQ_HG	BGT24LTR11 Q-channel – analog signal output – second gain stage
6	IFI_HG	BGT24LTR11 I-channel – analog signal output – second gain stage
7	PWM_OUT	External user-configurable GPIO with CCU4
8	OUT1	External GPIO pin (user configurable)
9	OUT2	External GPIO pin (user configurable)

The pin headers enhance the functionality of the module significantly. They enable probing the analog outputs of the sensor module and also probing various other signals provided to the IC. In principle, the accessibility of several pins on the radar IC and the IF signals available via the external pin headers enable interfacing the module with an external signal processor. Apart from the onboard user LED, the external headers provide two additional user-configurable GPIO pins from the microcontroller with a number of features.

*Note: In order to monitor VTUNE and DIVOUT signals at the external header, please assemble R38 (0Ω) and R39 (0Ω) respectively.*

### 4.10 Microcontroller unit – XMC1302

The Sense2GoL platform uses an XMC1302 32-bit ARM® Cortex™-M0 MCU to perform the radar signal processing. The XMC1302 takes care of communication with all the sub-systems on the radar module, enables data

**Hardware description**

acquisition, performs the complete radar signal processing (including sampling and FFT) and communicates the results via its UART to an external device. An XMC1302 in a 16-pin TSSOP package is used, featuring a 32 MHz CPU frequency, 16 kB Flash and 16 kB RAM. One 12-bit ADC helps implement the radar signal sampling and also acquires the various sensor data from the BGT24LTR11 MMIC. Please refer to [2] for detailed information on the XMC1302 microcontroller.

**4.11 Onboard debugger and UART connection**

The onboard breakable debugger supports two-pin SWD and UART communication. Both require the installation of SEGGER’s J-Link driver (refer to STEP 6, in Figure 2) which is part of the DAVE™ installation (refer to STEP 7 in Figure 3).

During installation of the J-Link driver make sure to select the option “**Install USB Driver for J-Link-OB with CDC**”, as shown in Figure 20.

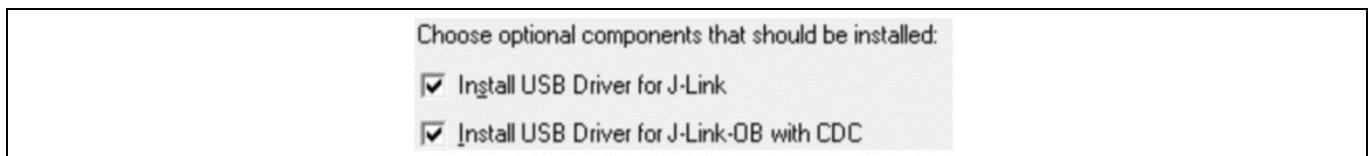

**Figure 20 Recommended installation options for the J-Link driver**

Table 8 shows the pin assignment of the XMC4200-VQFN48 MCU used for debugging and UART connection.

**Table 8 XMC4200 pins used for debugging and UART communication**

Port pin	Pin function
TMS (pin 33)	Data pin for debugging via SWD/SPD
TCK (pin 34)	Clock pin for debugging via SWD
0.1	Transmit pin for UART communication
0.0	Receive pin for UART communication

The debugger section supports communication between a PC/laptop and target XMC™ device via a UART-to-USB bridge). Therefore the UART pins of the target XMC4200 on the radar main board are connected to the TX/RX pins of the debug connector. The TX pin of the debugger MCU is connected to the RX pin of the target XMC4200 MCU. The RX pin of the debugger is connected to the TX pin of the XMC™ target device.

The connector J2 (five-pin header) on the breakable debugger board was used for internal development and testing purposes and is not recommended for customer use.

**4.12 User LEDs**

Some pins of the XMC1302 on the Sense2GoL module are connected to external LEDs on the top side of the PCB for status indication. Table 9 lists the user LEDs’ pin assignment.

**Table 9 User LEDs pin assignment**

LED	MCU port pin
D2 (orange LED)	P0.9 (12)
D4 (red LED)	P0.7 (10)
D5 (blue LED)	P0.5 (8)

Measurement results

## 5 Measurement results

Speed measurements were performed using a Doppler simulator and the Sense2GoL module for both approaching and departing configurations. The results can be seen in Figure 21.

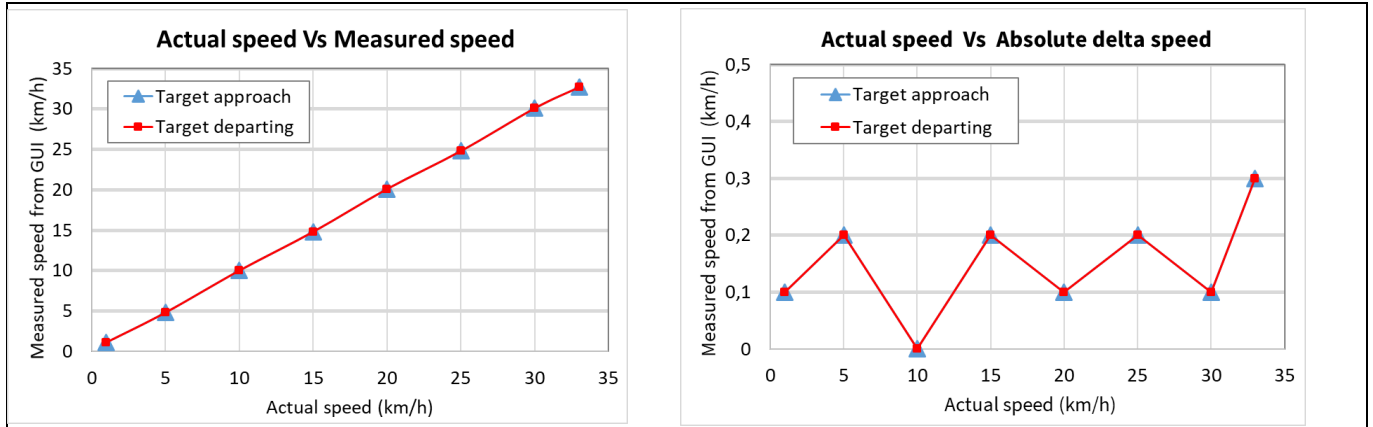

**Figure 21 Speed measurements (radar vs. Doppler simulator)**

The module is able to detect speeds between 0.5 and 33 km/h with an error of  $\pm 0.3$  km/h. For human targets, the module is able to detect movement up to a 15 m range.

## **Frequency band and regulations**

# **6 Frequency band and regulations**

## **6.1 24 GHz regulations**

Infineon's BGT24LTR11 radar sensor operates in the globally available 24 GHz bands. There is an industrial, scientific and medical (ISM) band from 24 to 24.25 GHz. However, each country may have deviating regulations in term of occupied bandwidth, maximum allowed radiated power, conducted power, spurious emissions, etc. Therefore, it is highly recommended to check the local regulations before designing an end product.

## **6.2 Regulations in Europe**

In Europe, the European Telecommunications Standards Institute (ETSI) defines the regulations. For more details on the ETSI standards, please refer to their document [EN 300 440 V2.2.1](#). Please note that some countries do not follow harmonized European standards. Thus it is recommended to check national regulations for operation within specific regions and monitor regulatory changes.

## **6.3 Regulations in the United States of America**

In the USA, the Federal Communications Commission (FCC) defines standards and regulations. The ISM band covers 24 to 24.25 GHz and one can operate field disturbance sensors anywhere within this band with allowed power limits for certain applications. For details, please refer to FCC section number [15.245](#) or [15.249](#).



**Authors**

**7 Authors**

Radar Application Engineering Team, Business Line “Radio Frequency and Sensors”

## References

### 8 References

- [1] Infineon BGT24LTR11N16 – 24 GHz Radar IC – [Datasheet](#)
- [2] Infineon XMC1300-bit ARM Cortex™-M0 microcontroller – [Datasheet](#)
- [3] Infineon BGT24LTR11 – [Product Brief](#)
- [4] Sense2GoL development kit – [Product Brief](#)
- [5] Infineon Application Note – [AN472 – “User’s Guide to BGT24LTR11N16”](#)
- [6] 24 GHz industrial radar – [FAQs](#)
- [7] ETSI Regulations – [EN 300 440 V2.2.1](#)
- [8] FCC Regulations – [15.245](#), [15.249](#)

**Revision history**

**Revision history**

<b>Document version</b>	<b>Date of release</b>	<b>Description of changes</b>
V1.0	2019-10-10	Initial version
V1.1	2020-02-13	Update on block diagram
V1.2	2020-07-13	Update on title incl. Sense2GoL MAKE

**Trademarks**

All referenced product or service names and trademarks are the property of their respective owners.

**Edition 2020-02-13**

**Published by**

**Infineon Technologies AG**

**81726 Munich, Germany**

**© 2020 Infineon Technologies AG.**

**All Rights Reserved.**

**Do you have a question about this document?**

**Email:** [erratum@infineon.com](mailto:erratum@infineon.com)

**Document reference**

**<AN\_1904\_PL32\_1905\_125153>**

**IMPORTANT NOTICE**

The information contained in this application note is given as a hint for the implementation of the product only and shall in no event be regarded as a description or warranty of a certain functionality, condition or quality of the product. Before implementation of the product, the recipient of this application note must verify any function and other technical information given herein in the real application. Infineon Technologies hereby disclaims any and all warranties and liabilities of any kind (including without limitation warranties of non-infringement of intellectual property rights of any third party) with respect to any and all information given in this application note.

The data contained in this document is exclusively intended for technically trained staff. It is the responsibility of customer's technical departments to evaluate the suitability of the product for the intended application and the completeness of the product information given in this document with respect to such application.

For further information on the product, technology delivery terms and conditions and prices please contact your nearest Infineon Technologies office ([www.infineon.com](http://www.infineon.com)).

**WARNINGS**

Due to technical requirements products may contain dangerous substances. For information on the types in question please contact your nearest Infineon Technologies office.

Except as otherwise explicitly approved by Infineon Technologies in a written document signed by authorized representatives of Infineon Technologies, Infineon Technologies' products may not be used in any applications where a failure of the product or any consequences of the use thereof can reasonably be expected to result in personal injury.