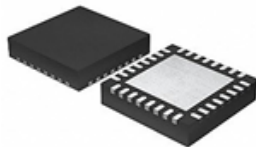


## 60 A electronic fuse for 12 V DC rail



VFQFPN (5x5x0.95) 32L

### Features

- 60 A continuous current
- Input voltage range from 5 to 18 V
- Adjustable current limit
- Input undervoltage lockout
- Integrated 0.85 mΩ power MOSFET
- Enable/disable pin
- Programmable turn-on time
- Accurate current monitor signal
- Precise temperature monitor
- Overcurrent and fault status flags
- Internal MOSFET diagnostic
- Thermal protection
- Thermal latch (STEF12H60) or auto-retry versions (STEF12H60A)
- QFN32-5x5 package
- Temperature range: -40 °C to 125 °C

### Applications

- Server main eFuse
- Hot-swap boards
- High power 12 V rail protection

Product status link

[STEF12H60](#)

### Description

The **STEF12H60** is a 60 A integrated electronic fuse optimized for monitoring the output current and the input voltage, over the 12 V DC power lines.

When connected in series to the main power rail, it is able to detect and react to overcurrent conditions. When an overload condition occurs, the device limits the output current to a safe value defined by the user.

A precise current monitor signal provides continuous information about the load current to the system controller IC.

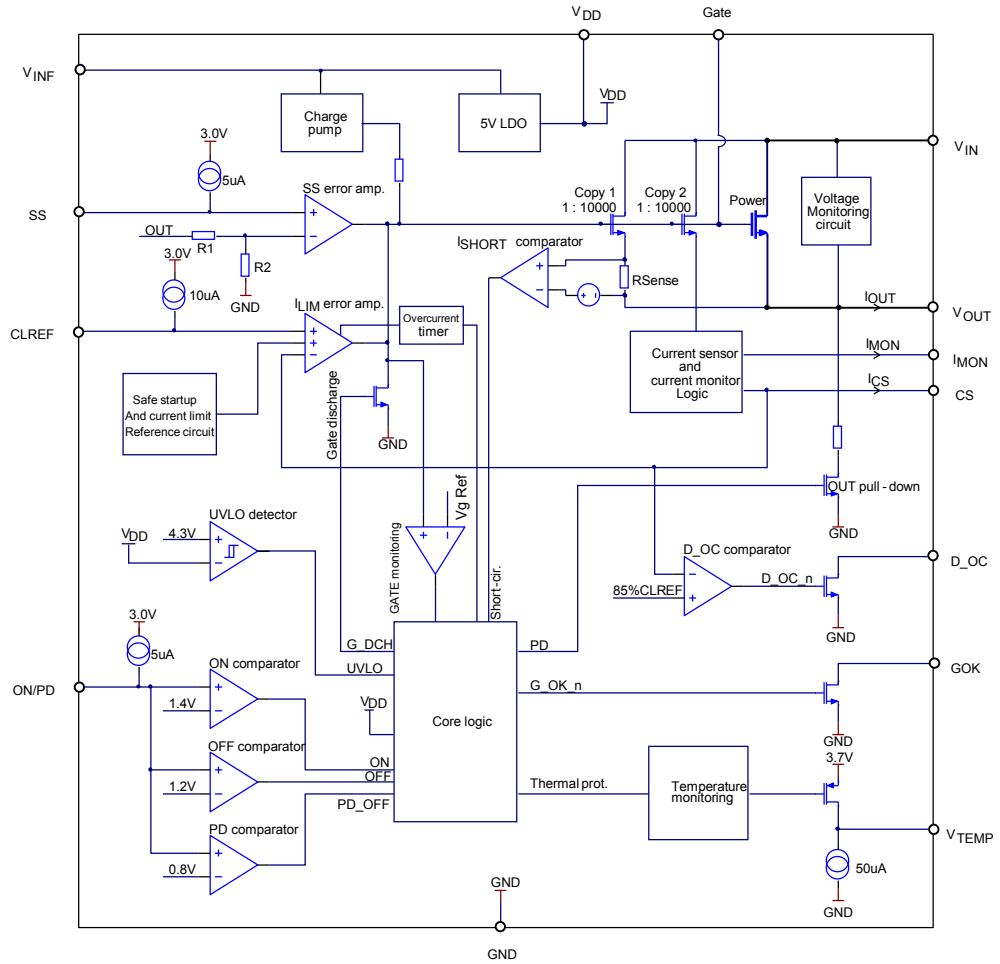
Similarly, a precise temperature sensor generates a monitor signal that permits the system controller to keep the device power dissipation under control.

Turn-on time is programmable, which helps control the inrush current during start-up operations.

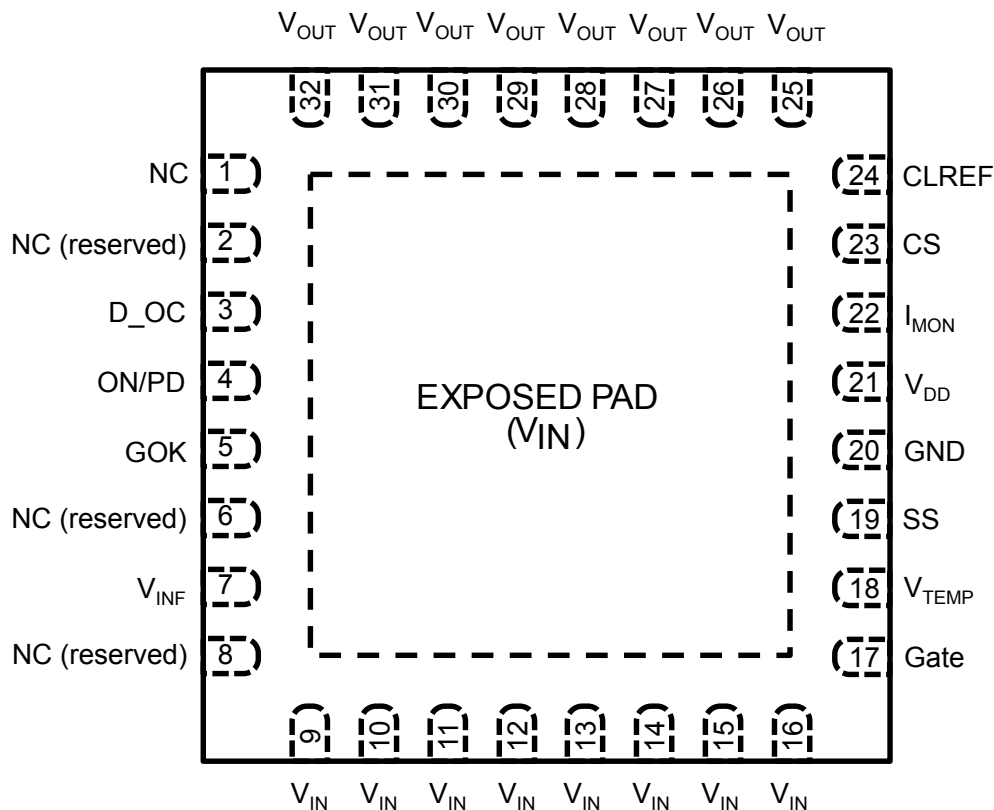
The device also embeds the undervoltage lock-out feature, self-diagnostic and absolute thermal protection.

1 Diagram

Figure 1. Block diagram



## 2 Pin configuration

**Figure 2. Pin connection (top view)**

**Table 1. Pin configuration**

Pin #	Symbol	Function
25-32	$V_{OUT}$	Output voltage of the eFuse. All pins must be connected together on the PCB
3	D_OC	Output pin, driven low if the current set-point is exceeded. It is a 5 V compliant open drain output
4	ON/PD	Enable/disable pin. This pin is internally pulled up. Pull this pin below the relevant threshold to shut down the chip. Pull it above threshold to enable the chip. This pin also commands the output pull-down resistance. A capacitor connected between this pin and GND can be used to increase the delay during startup
5	GOK	Gate-OK output pin. It signals that a shutdown, which was not commanded by the enable pin, has happened. 5 V compliant open drain output, low when device is in a fault condition
1	NC	Not internally connected. It can be connected to any potential
6, 8	NC/reserved	These pins are reserved and must be left floating
2	NC/reserved	This pin is reserved. If necessary, it can be connected to any potential up to $V_{IN}$
7	$V_{INF}$	Input voltage for internal circuits. It is connected to $V_{IN}$ through an R-C filter
9-16	$V_{IN}$	Input voltage of the eFuse. All these pins must be connected together and to the exposed pad
17	Gate	Gate pin of the internal MOSFET. This pin must be left floating or it can be bypassed to GND through an external R-C filter, to minimize the risk of oscillation in case of very small $C_{OUT}$ or high input/output inductance

Pin #	Symbol	Function
18	V <sub>TEMP</sub>	Temperature monitor pin
19	SS	Soft-start pin. A capacitor connected between this pin and GND determines the soft-start time. If it is left floating the start-up time is about 300 μs
20	GND	Analog device ground
21	V <sub>DD</sub>	Internal LDO output and compensation pin. It provides a regulated 5 V auxiliary output. This pin must be bypassed to GND via a 1 μF capacitor to ensure the correct functionality of the device
22	I <sub>MON</sub>	Current monitor pin. A resistor (R <sub>MON</sub> ) connected between this pin and GND generates a voltage proportional to the output current. A capacitor (C <sub>MON</sub> ) must be connected in parallel to R <sub>MON</sub> to filter the monitor signal
23	CS	Current feedback. A resistor (R <sub>CS</sub> ) connected between this pin and GND provides a feedback voltage for the current limit circuit and the overcurrent indicator (D_OC). Do not connect any capacitance to this pin
24	CLREF	Current limit set-point pin. Connect a resistor to GND or force an external control voltage to define the current limit set-point
EXP.PAD	VIN	Input voltage, internally connected to the power FET drain

### 3 Typical application circuit

Figure 3. Typical application diagram (external controller used for CLREF pin)

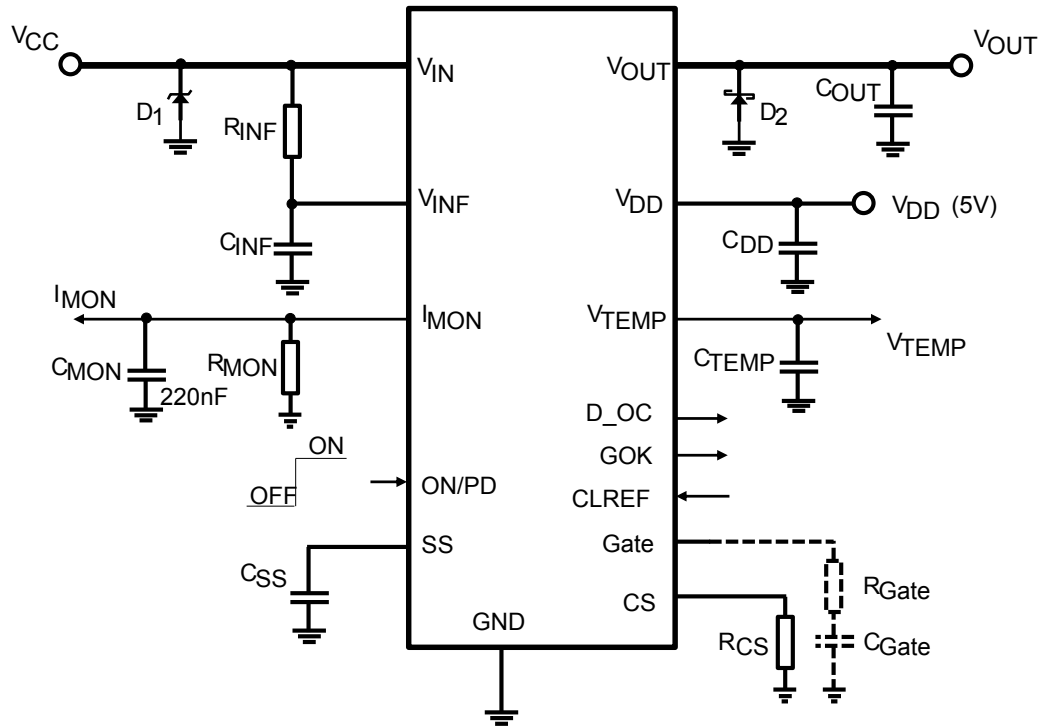
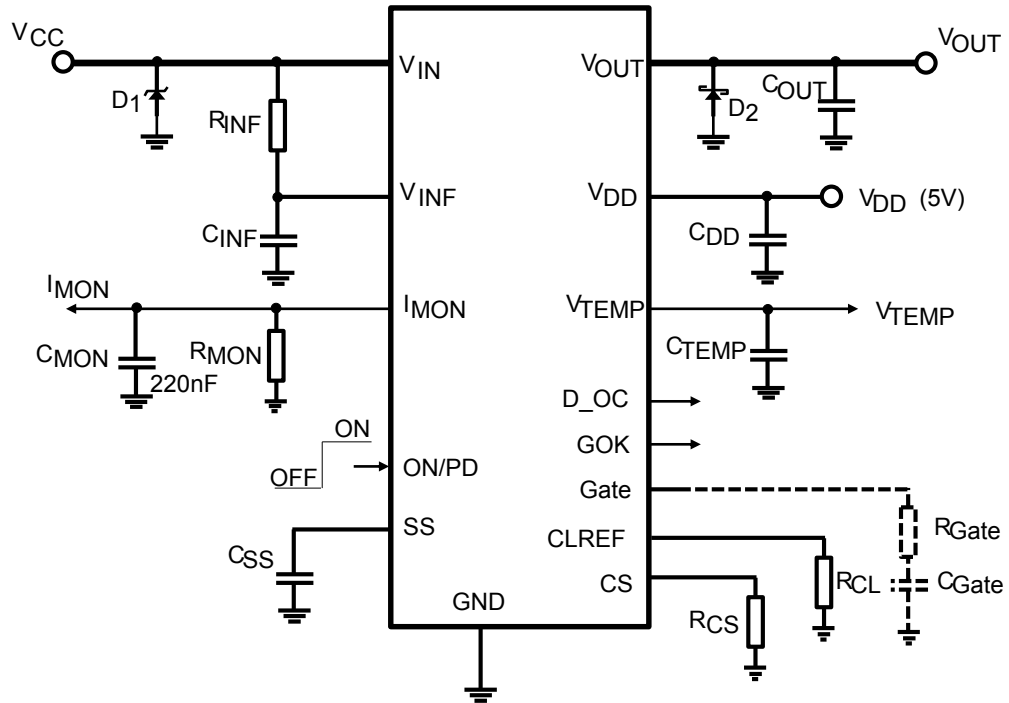


Figure 4. Typical application diagram (current limit fixed via  $R_{CL}$ )



## 4 Absolute maximum ratings

**Table 2. Absolute maximum ratings**

Symbol	Parameter	Value	Unit
$V_{IN}$	Input supply voltage	-0.3 to 20	V
$V_{INF}$	Input supply voltage	-0.3 to $V_{IN}$	V
$V_{OUT}$	Output voltage	-0.3 to $V_{IN}$	V
$V_{DD}$	LDO output voltage	-0.3 to 7	V
All other pins	Pin voltage	-0.3 to 6	V
$I_{OUT}$	Continuous output current	75	A
$I_{DD}$	LDO continuous output current	60	mA
ESD	Charge device model	$\pm 500$	V
	Human body model	$\pm 2000$	
$T_{J-OP}^{(1)}$	Operating junction temperature	-40 to 125	°C
$T_{J-MAX}$	Maximum junction temperature	150	°C
$T_{STG}$	Storage temperature	-55 to 150	°C

1. The thermal limit is set above the maximum operating temperature. It is not recommended to operate the device at temperatures greater than the maximum ratings for extended periods of time.

**Note:** Absolute maximum ratings are those values beyond which damage to the device may occur. Functional operation under these conditions is not implied. Exposure to absolute-maximum-rated conditions may affect device reliability.

**Table 3. Thermal data**

Symbol	Parameter	Value	Unit
$R_{thj-a}$	Thermal resistance, junction-to-ambient	26 <sup>(1)</sup>	°C/W
		22 <sup>(2)</sup>	

1. JEDEC still air natural convection test as per JESD 51-2 A, at ambient temperature of 25 °C by using JEDEC (JESD 51-7) 4L PCB FR4 board with using 1 sq-in pad, 1 oz Cu.

2. Forced moving air environment (100 LFM).

**Table 4. Recommended operating conditions**

Symbol	Parameter	Test conditions	Min.	Typ.	Max.	Unit
$V_{IN}$	Input voltage		8	12	15	V
$I_{OUT}$	Continuous output current				60	A
$I_{DD}$	LDO continuous output current	$V_{INF} = 5.5\text{ V}$			50	mA
$R_{CS}$	Current set resistor		1.8		4	k $\Omega$
$V_{CLREF}$	Control voltage range		0.2		1.4	V
$C_{OUT}$	Output capacitance		47			$\mu\text{F}$
$t_{ss}$	Soft-start duration		10	50	100	ms
$C_{DD}$	$V_{DD}$ capacitor value <sup>(1)</sup>		1	2.2	10	$\mu\text{F}$

1.  $V_{DD}$  capacitor is mandatory to ensure the internal regulator stability and the device functionality .

*Note:* Functional operation beyond the recommended operating conditions is not implied.



## 5 Electrical characteristics

$T_J = -40\text{ }^{\circ}\text{C}$  to  $+125\text{ }^{\circ}\text{C}$ .

Typical values refer to  $T_J = 25\text{ }^{\circ}\text{C}$ ,  $V_{IN} = V_{INF} = 12\text{ V}$ ,  $V_{ON/PD} = \text{floating}$ ;  $C_{OUT} = 100\text{ }\mu\text{F}$ ; unless otherwise specified.

Min. and max. values are guaranteed by design and characterization through statistical correlation.

**Table 5. Electrical characteristics**

Symbol	Parameter	Test conditions	Min.	Typ.	Max.	Unit
<b>Input section</b>						
$V_{IN}$	Operating input voltage		5	12	18	V
$I_q$	Quiescent current	Device operating, no load ( $V_{ON/PD} > 1.4\text{ V}$ )		650	1000	$\mu\text{A}$
		Fault condition		250		
		Off-state, $V_{ON/PD} = 0\text{ V}$ , $V_{INF} = 16\text{ V}$		200	400	
<b>LDO</b>						
$V_{DD}$	LDO output voltage	$I_{DD} = 1\text{ mA}$ , $V_{INF} = 6\text{ V}$	4.6	4.9	5.2	V
$I_{DDmax}$	LDO short-circuit current <sup>(1)</sup>	$V_{DD} = 0\text{ V}$	60	120		mA
$V_{DROP}$	LDO dropout voltage	$I_{DD} = 30\text{ mA}$	66	100	160	mV
$V_{DD\_ON}$	UVLO rising threshold		4.1	4.3	4.6	V
$V_{DD\_OFF}$	UVLO falling threshold		3.8	4.0	4.2	V
<b>Startup</b>						
$I_{SS}$	Soft-start capacitor charging current		4.5	5.2	6	$\mu\text{A}$
$t_{SSMAX}$	Soft-start max. time	if $V_{OUT} < 90\%$ of $V_{IN}$ after $T_{SSMAX}$ shutdown is forced		200		ms
$A_S$	Soft-start gain	Relation between internal soft-start signal ramp and $V_{OUT}$		10		V/V
<b>Power MOSFET</b>						
$R_{DS(on)}$	On-resistance	$T_J = 25\text{ }^{\circ}\text{C}$		0.85	1.1	m $\Omega$
$I_L$	Off-state leakage current	$V_{ON/PD} = 0\text{ V}$ , $V_{IN} = 16\text{ V}$ , $T_J = 25\text{ }^{\circ}\text{C}$			1	$\mu\text{A}$
<b>Current limit and current monitor circuit</b>						
$V_{CS\_TH}$	Current limit activation threshold ( $V_{CS} = I_{RCS} \times R_{CS}$ )	$V_{OUT} > 80\%$ of $V_{IN}$	97	100	103	% of $V_{CLREF}$
$V_{CL\_MAX}^{(2)}$	Maximum CL reference voltage		1.55	1.6	1.65	V

Symbol	Parameter	Test conditions	Min.	Typ.	Max.	Unit
$V_{CL\_FD}$	Internal voltage reference for foldback current limit at startup	$V_{OUT}$ is lower than 40% of $V_{IN}$	130	150	170	mV
$V_{CL\_ST}$	Internal voltage reference for current limit at startup	$V_{OUT}$ is between 40% and 80% of $V_{IN}$	470	500	530	mV
$t_{CL}$	Current limit response time <sup>(3)</sup>	from $V_{CS} > V_{CLREF}$ until current limit		100		$\mu$ s
$I_{CL}$	CLREF pin internal biasing current	From CLREF pin into 1 V source	9.4	10	10.4	$\mu$ A
$V_{CL\_MAX}$	Maximum voltage of the CLREF pin internal biasing source			3.0		V
$I_{RCS}, I_{MON}$	Current sense/monitor accuracy	$T_j = 25\text{ }^\circ\text{C}$ , 5 A < $I_{OUT}$ < 60 A <sup>(3)</sup> (4)	-3	1	3	%
		$T_j = 0$ to 85 $^\circ\text{C}$ , 5 A < $I_{OUT}$ < 60 A (3)	-6		6	%
$A_{CS}, A_{MON}$	Current sense and current monitor gain	$I_{RCS}/I_{OUT}$ , $I_{MON}/I_{OUT}$ , $T_j = 0$ to 85 $^\circ\text{C}$ , 5 A < $I_{OUT}$ < 60 A	9.4	10	10.6	$\mu$ A/A
$t_{SH}$	Shut-down timer <sup>(3)</sup>	From current limit detection to MOSFET turn-off		250		$\mu$ s
$I_{SC}$	Short-circuit current limit <sup>(3)</sup>			100		A
$T_{SC}$	Short-circuit protection response time <sup>(3)</sup>	From $I_{OUT} > I_{SC}$ until MOSFET gate pull-down		500		ns
$V_{MON\_MAX}$	Internal current source maximum voltage	Internal pull-up voltage on $I_{MON}$ pin		3.0		V
<b>ON/PD (chip-enable pin)</b>						
$V_{OFF}$	Low level input voltage	Output disabled/PD activated	1.11	1.2	1.29	V
$V_{ON}$	High level input voltage	Output enabled	1.3	1.4	1.5	V
$V_{PD}$	Pull-down de-activation threshold	Pull-down de-activated	0.71	0.8	0.89	V
$t_{ON}$	Initial delay time	From $V_{ON/PD} > V_{ON}$ to soft-start beginning	0.8	1	1.2	ms
$I_{ON/PD}$	Enable pin bias current		4	5	6	$\mu$ A
$V_{ON/PD\_MAX}$	Internal current source maximum voltage	Internal pull-up voltage on $I_{MON}$ pin		3.0		V
$R_{PD}$	Output pull-down resistance	$V_{OUT} = 12\text{ V}$ , pull-down activated		0.72		k $\Omega$

Symbol	Parameter	Test conditions	Min.	Typ.	Max.	Unit
$t_{PD}$	Output pull-down delay timer	From $V_{OFF} < V_{ON/PD} < V_{PD}$		2		ms
<b>Temperature monitor</b>						
$V_{TEMP}$	$V_{TEMP}$ voltage	$T = 25\text{ }^{\circ}\text{C}$		450		mV
	Temp coefficient <sup>(3)</sup>	$T = 0\text{ }^{\circ}\text{C}$ to $125\text{ }^{\circ}\text{C}$		10		mV/ $^{\circ}\text{C}$
	Load capability	Maximum current			4	mA
	Pull-down current	$T = 25\text{ }^{\circ}\text{C}$		50		$\mu\text{A}$
<b>Status line</b>						
GOK	Gate-OK output voltage	$I_{SINK} = 1\text{ mA}$			0.1	V
	Leakage current	$V_{GOK} = 5\text{ V}$			1	$\mu\text{A}$
$V_{OC}$	Overcurrent detection threshold	$V_{CS}$ voltage threshold that triggers D_OC low	83	85	87	% $V_{CLREF}$
D_OC	Overcurrent monitor signal active low voltage	$I_{SINK} = 1\text{ mA}$ , $V_{CS} > V_{OC}$			0.1	V
	Leakage current	$V_{D\_OC} = 5\text{ V}$ , $V_{CS} < V_{OC}$			1	$\mu\text{A}$
$T_D$	D_OC signal response time <sup>(3)</sup>			1		$\mu\text{s}$
<b>Thermal protection</b>						
TSD	Shutdown temperature <sup>(3)</sup>	GOK pulled low		140		$^{\circ}\text{C}$
$T_{Retry}$	Autoretry delay time (only on the STEF12H60APUR)	From shutdown due to fault to automatic restart		1		s
<b>Internal MOSFET diagnostics</b>						
$V_{DS\_TH}$	Drain-source short detection threshold	If $V_{OUT} > V_{DS\_TH}$ at startup, startup is postponed		90		% of $V_{IN}$
$V_{DS\_OK}$	Drain-source voltage good detection threshold	If $V_{OUT} < V_{DS\_OK}$ startup is resumed		70		% of $V_{IN}$
$V_{OUT\_LOW}$	Low $V_{OUT}$ detection threshold	After startup, if $V_{OUT} < V_{OUT\_LOW}$ , the device is turned off		90		% of $V_{IN}$
$V_{DG\_SH}$	Gate-drain short detection voltage threshold	If $V_G > V_{DG\_SH}$ after enable by ON pin, startup is postponed		3.1		V
$V_{DG\_OK}$	Gate-drain voltage good detection threshold	If $V_G < V_{DG\_OK}$ startup is resumed		3		V
$V_{G\_LOW}$	Gate fault detection threshold	If $V_{GD} < V_{G\_LOW}$ device is turned off		5.7		V
$T_{G\_LOW}$	Get fault timer in normal operation	After $T_{SSMAX}$ elapses, time from $V_{GD} < V_{G\_LOW}$ transition to gate fault detection		200		ms

1. Pulsed test. The internal LDO is not equipped with thermal protection. Short-circuit duration must not be longer than 1 ms to avoid damage.
2. If the voltage on CLREF pin is higher than  $V_{CL\_MAX}$  internal reference, the current limit reference voltage is clamped to  $V_{CL\_MAX}$ .
3. Guaranteed by design, but not tested in production.
4. MOSFET fully conducting, at minimum  $R_{ON}$ .

## 6 Device functional description

The STEF12H60 is a 12 V intelligent load switch, which is able to limit the current during fault events, such as: output overload or short-circuit.

The current limiting loop is also used during the start-up phase of the eFuse to avoid startups into faulty loads. During the normal operation, the eFuse works as a low-resistance power switch, therefore the output voltage follows the input one. In case of overcurrent event, the eFuse limits the  $V_{GS}$  of the internal MOSFET switch, in order to clamp the output current to a safe value.

If the fault persists, after a predefined safety timer, or in case the die temperature hits the thermal protection threshold, due to the increased power dissipation, the device goes into shutdown, the internal switch is turned-off and the load is disconnected from the power supply. The device is latched in this off-state until a power supply re-cycle is performed. The auto-retry version instead, is able to re-try starting the device after a fault event, with a typical delay of 1 ms.

The current limit and soft-start features are programmable by the users, by external components.

### 6.1 UVLO ON/PD function

The device is supplied through the  $V_{IN}$  pins, which carry the power directly to the internal power MOSFET drain connection, and the  $V_{INF}$  pin, which is the input of the internal regulator, used to supply the analog and logic circuits. This pin must be connected externally to  $V_{IN}$  through an R-C filter (see [Section 3 Typical application circuit](#)).

The UVLO (undervoltage lockout) monitors the voltage of the internally regulated  $V_{DD}$  node and turns on the device when  $V_{DD} > V_{DD\_ON}$  (typically 4.3 V). If  $V_{DD}$  falls below the UVLO hysteresis threshold ( $V_{DD} < V_{DD\_OFF}$ ), the device is turned off including the reset of fault state.

### 6.2 ON/PD function

During turn-on, provided that the UVLO rising threshold has been surpassed, the start-up procedure begins once the device is enabled via the ON/PD pin. The ON/PD is a logical input with a dual functionality, according to the following description:

1. *Enable/disable the device:* when  $V_{ON/PD} > V_{ON}$ , the device is enabled. If  $V_{ON/PD}$  is pulled down to  $V_{OFF}$  or a lower voltage, the device is disabled and the output is shut down. In case the shutdown occurred due to a fault (thermal, overcurrent, failed startup), the device cannot be turned on again via the ON/PD pin. To reset the device from this latched status, a power supply re-cycle is necessary. Alternatively, a reset can be forced without turning off the power supply, by pulling  $V_{DD}$  pin below the UVLO voltage and then releasing it.
2. *Activate/deactivate the output discharge feature (PD – output pulldown):* if  $V_{ON/PD}$  is kept between  $V_{PD}$  (typ. 0.8 V) and  $V_{OFF}$  (typ. 1.2 V) for at least 2 ms ( $t_{PD}$ ), the integrated 0.77 k $\Omega$   $R_{PD}$  discharging resistor is connected between  $V_{OUT}$  and GND.

The ON/PD pin has an internal pull-up current generator connected to the internal LDO therefore, if the pin is not connected to an external controller IC, it goes to the ON-state (device enabled).

The 5  $\mu$ A ON/PD bias current can be used to charge an external capacitor, in this manner prolonging the initial delay time, defined as the time interval between power supply reaching the UVLO threshold and the output voltage controlled ramp-up initialization.

### 6.3 Soft-start

The device provides monotonic, controlled start-up ramp, in order to keep the inrush current under control. The output voltage rise time can be set by an external  $C_{SS}$ , which is charged with a constant current during the start-up phase. The soft-start range is adjustable from 1 to 100 ms.

Given the required ramp-up time, the  $C_{SS}$  capacitance can be calculated according to the following equation:

$$C_{SS} = \frac{(t_{SS} \times I_{SS} \times 10)}{V_{IN}} \quad (1)$$

where  $V_{IN}$  is typically 12 V and  $t_{SS}$  is in the 10-100 ms range.

The table below shows typical values of soft-start duration calculated with standard capacitors and typical  $I_{SS}$  value.

**Table 6. Output voltage rise time vs.  $C_{SS}$  value ( $V_{IN} = 12\text{ V}$ )**

Symbol	Value							
$C_{SS}$ (nF)	47	82	120	180	220	270	330	390
$T_{SS}$ (ms)	10.8	18.9	27.7	41.5	50.8	62.3	76.2	90

**Important:** Soft-start capacitor must be always connected to ensure controlled operation during startup. In case of absence/bad connection of the  $C_{SS}$ , the start-up phase is short (300  $\mu\text{s}$ ). This might result in significantly high charging current, eventually leading to the device shutdown for overcurrent/overtemperature fault. To prevent the device from starting into faulty loads (such as: resistive load, or damaged bulk output capacitors) the following start-up control flow is applied:

- Start-up fold-back current limit: current limit value during start-up phase is dependent on the sensed output voltage. At the very beginning of startup, when the output voltage is close to zero, the current limit internal reference voltage is reduced to  $V_{CL\_FD}$ . Any higher current limit value set by the user via the CLREF pin is overridden by the device
- Start-up current limit: during the ramp-up phase, the current limit internal reference voltage is reduced to  $V_{CL\_ST}$ . Any higher current limit value, set by the user via the CLREF pin, is overridden by the device
- Maximum start-up time: start-up longer than 200 ms is always aborted by the device. If  $V_{OUT}$  does not reach 90% of  $V_{IN}$  in 200 ms, the device is turned off and the GOK fault indicator is asserted low

The CLREF normal functionality is resumed at the end of start-up phase ( $V_{OUT} > 80\%$  of  $V_{IN}$ ). Adding a capacitor in parallel to the ON/PD pin, the initial  $t_{ON}$  delay time between valid  $V_{IN}$  value and controlled output ramp-up start ( $V_{OUT} = 1\text{ V}$ ) can be increased.

The default delay time without  $C_{ON}$  capacitor is typically 1.25 ms.

## 6.4 Normal operating conditions

Once the start-up phase ends, the STEF12H60 eFuse behaves like a mechanical fuse, supplying the load connected to its output with the same voltage shown at its input, minus the small voltage fall due to the N-channel MOSFET  $R_{DS(on)}$ . The status line open-drain indicators GOK and D\_OC provide information about the status of the device.

## 6.5 Current sensing and current limit

When an overload event occurs, the current limiting circuit reduces the conductivity of the power MOSFET, in order to clamp the output current at the value defined by the user by the voltage set on CLREF pin. Current limit function consists of two sub-circuits:

- the **current sense (CS)** circuit, responsible for sensing the load current and providing a feedback signal to detect overcurrent. It relies on a small copy-MOSFET built into the integrated power MOSFET to generate a replica of the load current, proportional by  $A_{CS} = I_{RCS}/I_{OUT} = 10\ \mu\text{A/A}$ , into the external  $R_{CS}$  resistor attached to the eFuse

This current creates a variable  $V_{CS}$  voltage across the resistor, defining the eFuse working current CS, which is continuously compared to the current limit reference voltage present on the CLREF pin.

- the **current limit (CL)** circuit defines the reference threshold for the intervention of the current limitation function. This reference point is a voltage ( $V_{CLREF}$ ) usually provided externally by the system control IC to the CLREF pin, and continuously compared internally to the feedback signal from CS circuit. In this manner, the current limit point can be throttled to satisfy the system power requirements during operation.

In simple standalone designs, such as the one shown in [Figure 4. Typical application diagram \(current limit fixed via  \$R\_{CL}\$ \)](#), where no control IC is present, the reference signal can be generated by connecting a resistor between CLREF pin and GND. An integrated bias generator sources 10  $\mu$ A of current to the  $R_{CL}$  resistor, generating a fixed  $V_{CLREF}$ , which sets the current limit thresholds.

To ensure reliability, the signal on CLREF is internally clamped to  $V_{CL\_MAX}$  therefore, even in case of wrong signal provided externally on the pin, a safety current limit threshold is always present.

An overcurrent event is detected when the voltage on CS pin overcomes the  $V_{OC}$  threshold, which is typically 85% of the voltage at CLREF pin ( $V_{CS} > V_{OC}$ ). In this case the status D\_OC indicator is pulled down. If the load status reverts to normality ( $V_{CS}$  falls below 75% of  $V_{CLREF}$ ), D\_OC is released. Based on the value of  $R_{CS}$  resistor, the load current level for D\_OC triggering can be evaluated by using the following equation:

$$I_{OUT} = \frac{V_{OC}}{R_{CS} \times A_{CS}} \quad (2)$$

In case of overcurrent detection, when  $V_{CS}$  surpasses  $V_{CLREF}$ , the  $V_{GS}$  of internal MOSFET is immediately modulated in order to clamp the load current to the  $I_{LIM}$  value defined by user via CLREF pin, according to the following:

$$I_{LIM} = \frac{V_{CLREF}}{R_{CS} \times A_{CS}} \quad (3)$$

During current limitation, additional protection features are activated, in order to keep the total power dissipation under control and protect the device and the system. In particular, a 250  $\mu$ s current limit timer ( $t_{SH}$ ) starts after overload detection. Once timer elapses, the internal MOSFET is shut down and the GOK indicator is pulled to low status, to inform the system controller that a shutdown not due to ON/PD (fault) happened.

Moreover, due to high power dissipation in current limit condition, if the die temperature increases too much and hits the thermal protection threshold (140  $^{\circ}$ C typ.), the thermal protection intervenes, turning off the internal MOSFET and asserting GOK low.

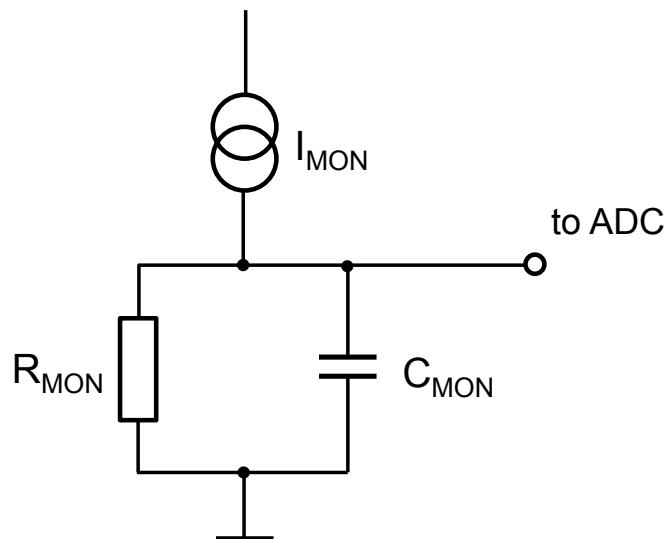
A second level current limit ( $I_{SC}$ ) is quickly activated in case the load current overcomes 100 A.

This additional protection, fixed by design, is able to respond to short-circuit events on the output. In such occurrence the device is immediately shut down and the D\_OC pin is asserted.

## 6.6 Current monitor

The device is equipped with a current monitoring capability that allows the system controller to read the current flowing through the fuse. An  $I_{MON}$  current proportional to the load current flowing through the eFuse is imposed on an external  $R_{MON}$ , converting the sensed current into a voltage for further processing by the ADC. The  $I_{MON}$  signal is the output of a chopper amplifier, therefore an external bypass capacitor is suggested to reduce the output ripple and to provide a smooth signal (see [Figure 6. Quiescent current vs. temperature](#)). The suggested minimum value for the filter capacitor is 3.9 nF. Lower values result in a worse ripple amplitude.

The current, monitoring amplifier gain and defined as  $A_I = I_{MON} / I_{OUT}$ , is typically 10  $\mu$ A/A.

**Figure 5. Current monitor simplified circuit**


## 6.7 Temperature monitor and thermal shutdown functions

The STEF12H60 embeds two thermal sensors, each one accomplishing a specific function:

- **Overtemperature sensor:** this is embedded into the power MOSFET. It monitors the power MOSFET temperature, which is subjected to very fast increases during overload events. If the device temperature exceeds the thermal threshold, typically 140 °C, the thermal shutdown circuit turns the power MOSFET off, thus disconnecting the load. The GOK pin is pulled down. The thermal shutdown protection is always active and overrides any other protection/control feature of the device.
- **Temperature sensor:** this consists of precise thermal sensors embedded in the controller die. The purpose is to statically monitor the overall device temperature, and generate a precise monitor signal ( $V_{TEMP}$ ) accordingly. Overall typical accuracy is +/- 5 °C.

The device can be reset from a thermal shutdown condition by pulling the  $V_{DD}$  pin below the UVLO threshold or by re-cycling the supply voltage.

## 6.8 Status indicators and fault conditions

Two open-drain flags can be used to monitor the status of the eFuse, along with the current and temperature monitor signals.

- **D\_OC - Overcurrent indicator:** in normal operation and during startup it is released. It is pulled down upon detection of an overload (see Section 6.5 Current sensing and current limit)
- **GOK - gate ok indicator:** this indicator informs that there was a shutdown that was not commanded by the enable pin (ON/PD). In particular, this pin is pulled low when:
  - too low input voltage:  $V_{DD}$  lower than UVLO threshold
  - too long start-up time:  $V_{OUT}$  does not reach 90% of  $V_{IN}$  in 200 ms
  - too long current limit: a current limit event is longer than  $t_{SH}$  (250  $\mu$ s typ.)

During the startup, GOK is released once UVLO is reached, therefore it cannot be used directly as a Power Good flag.

## 6.9 Diagnostic functions and protections

The STEF12H60 embeds several internal diagnostic features that prevent fault condition induced internally that may affect the application (refer to Table 5. Electrical characteristics):

- Power MOSFET gate leakage check during startup and normal operation ( $V_{Gate}-V_{IN} < 5.6$  V)
- Gate shorted-to- $V_{IN}$



- Drain to source short (disabled mode)
- $V_{OUT}$  too low ( $V_{OUT} < 90\%$  of  $V_{IN}$ ) after soft-start
- $V_{OUT}$  does not reach 90% of  $V_{IN}$  in 200 ms during startup
- Charge pump error
- Pull-down circuit error

In any case of fault GOK indicator is pulled down and the soft-start capacitor is discharged.

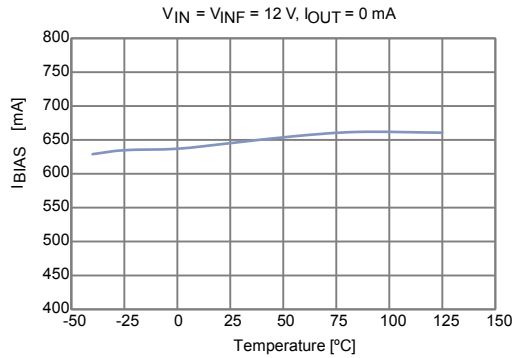
## 6.10 Latch (STEF12H60PUR) and auto-retry versions (STEF12H60APUR)

The STEF12H60 electronic fuse is offered in two variants that differ in how the device reacts after a fault condition (see [Section 6.8 Status indicators and fault conditions](#) and [Section 6.9 Diagnostic functions and protections](#)). In particular, the STEF12H60PUR latches off after a fault and can be reset by pulling the  $V_{DD}$  pin below the UVLO threshold or by re-cycling the supply voltage. The STEF12H60APUR instead stays in OFF mode for 1 s. ( $T_{Retry}$ ) and after restarts automatically, initiating a soft-start cycle. The number of restart cycles is not internally limited.

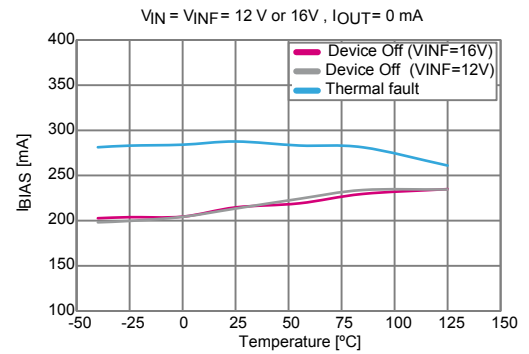
## 7 Typical characteristics

( $C_{IN} = 1 \mu F$ ;  $C_{OUT} = 10 \mu F$ ,  $T_J = 25^\circ C$  unless otherwise specified)

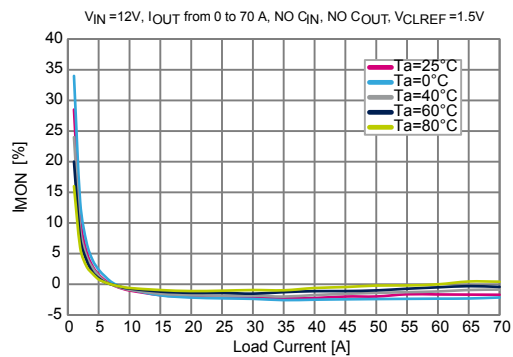
**Figure 6. Quiescent current vs. temperature**



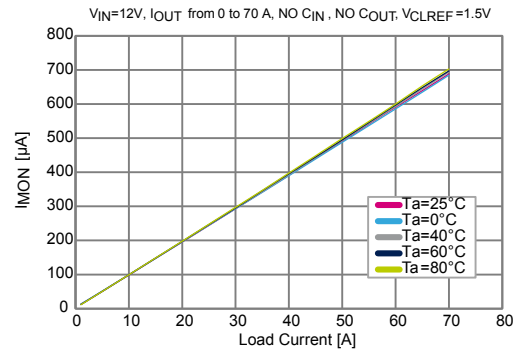
**Figure 7. Shutdown current vs. temperature**



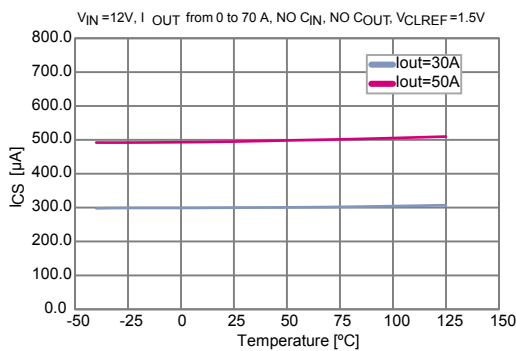
**Figure 8.  $I_{MON}$  gain accuracy vs. load current and temperature**



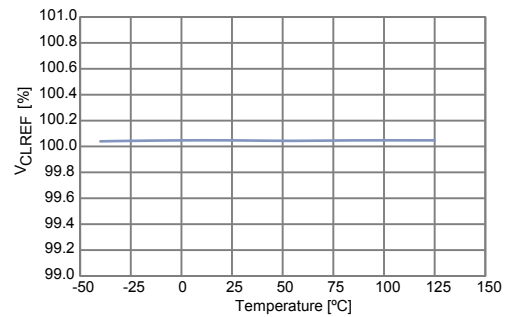
**Figure 9.  $I_{MON}$  current vs. load current**



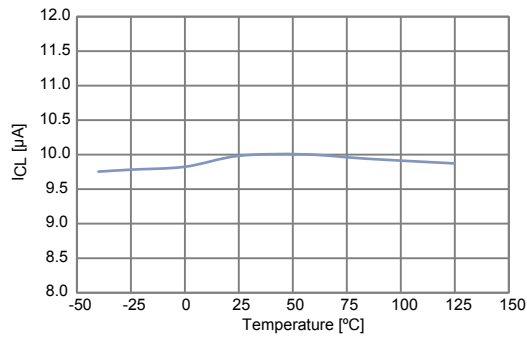
**Figure 10. CS current vs. temperature**



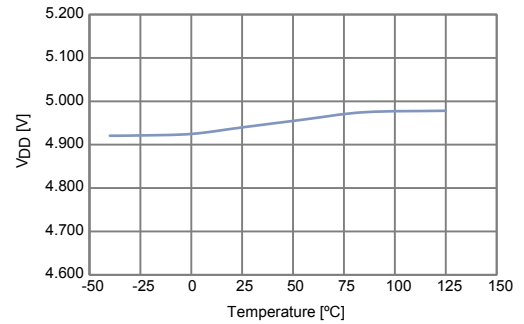
**Figure 11.  $V_{CLREF}$  threshold vs. temperature**



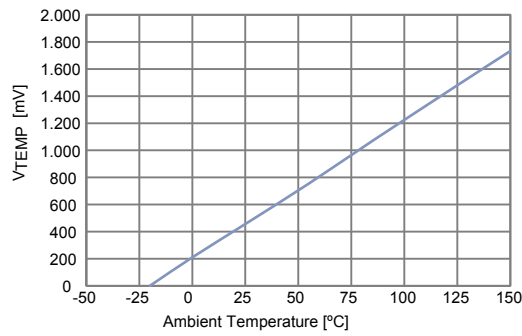
**Figure 12. CLREF pin bias current vs. temperature**



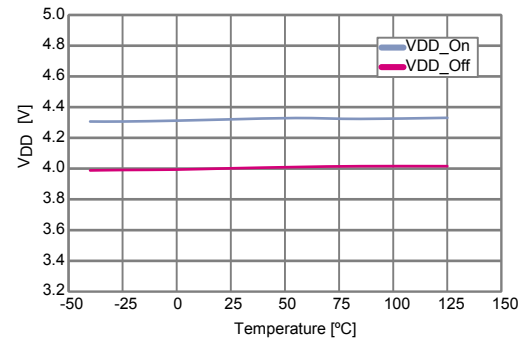
**Figure 13. V<sub>DD</sub> voltage vs. temperature**



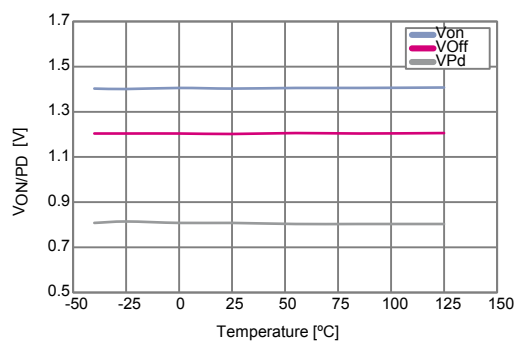
**Figure 14. V<sub>TEMP</sub> voltage vs. temperature**



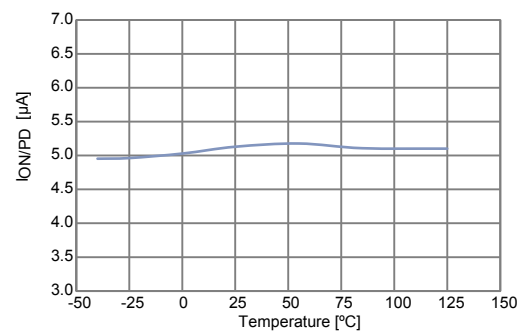
**Figure 15. UVLO thresholds vs. temperature**



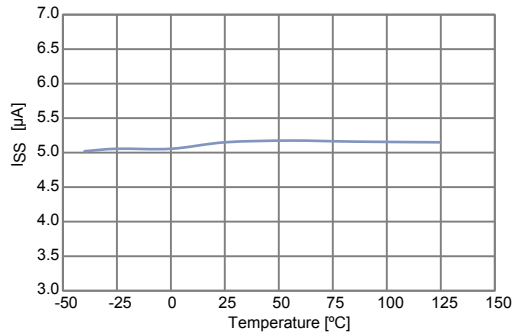
**Figure 16. ON/PD thresholds vs. temperature**



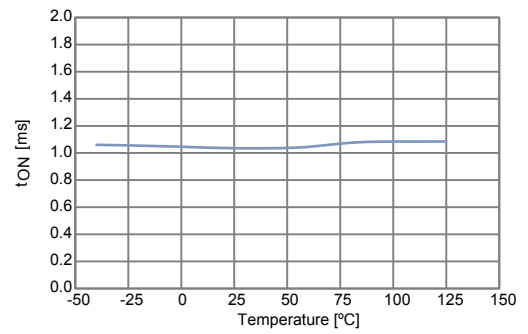
**Figure 17. ON/PD pin current vs. temperature**



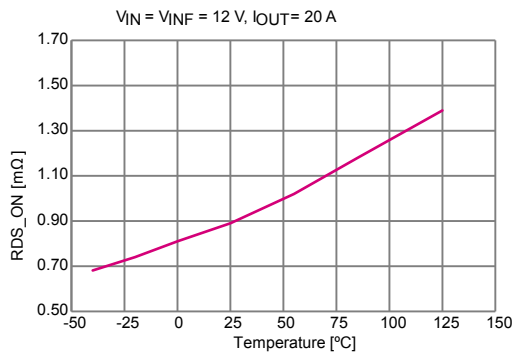
**Figure 18. SS pin bias current vs. temperature**



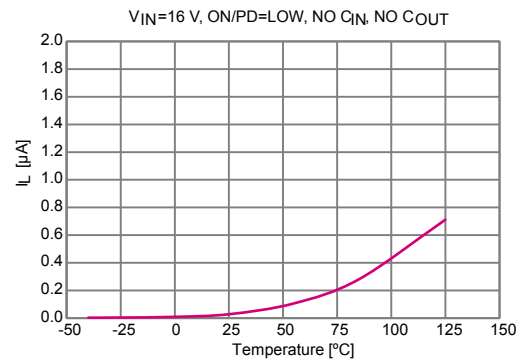
**Figure 19. Turn-on initial delay vs. temperature**



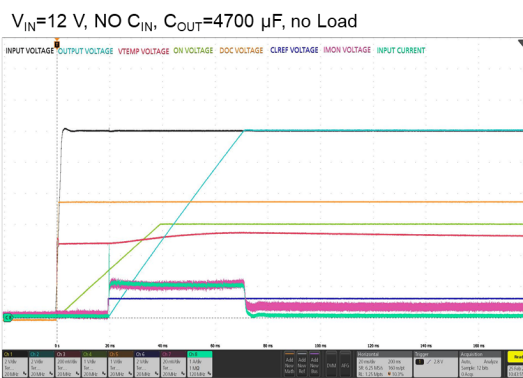
**Figure 20. On-resistance vs. temperature**



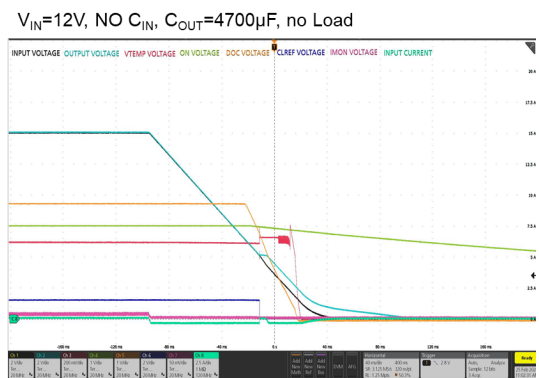
**Figure 21. Off-state leakage current vs. temperature**



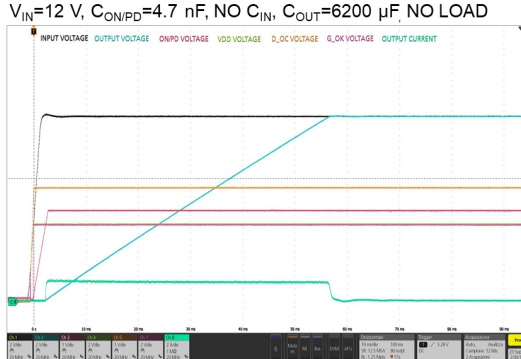
**Figure 22. Startup by  $V_{IN}$  (no load)**



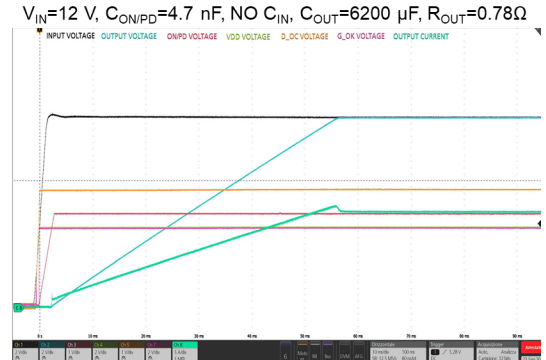
**Figure 23. Shutdown by  $V_{IN}$  (no load)**



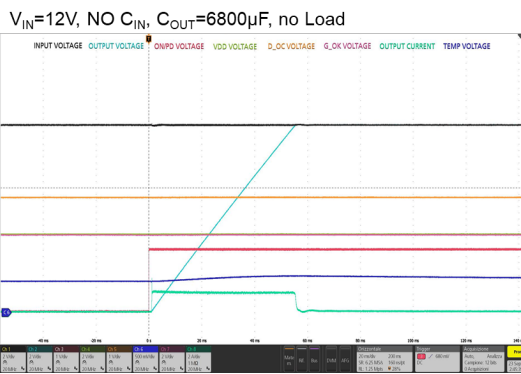
**Figure 24. Startup by  $V_{IN}$  ( $C_{OUT} = 6200 \mu\text{F}$ , no load)**



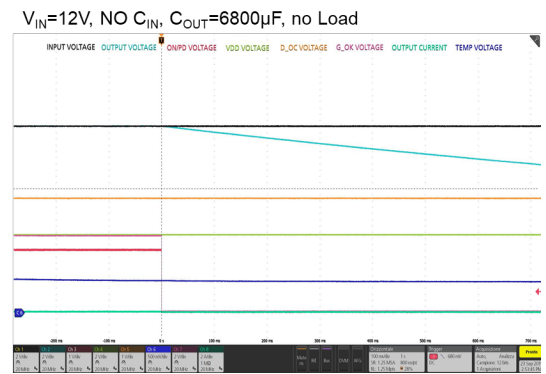
**Figure 25. Startup by  $V_{IN}$  ( $C_{OUT} = 6200 \mu\text{F}$ , 15 A, res. load)**



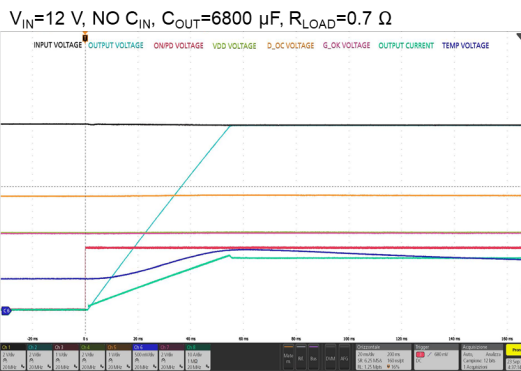
**Figure 26. Startup by ON/PD (no load)**



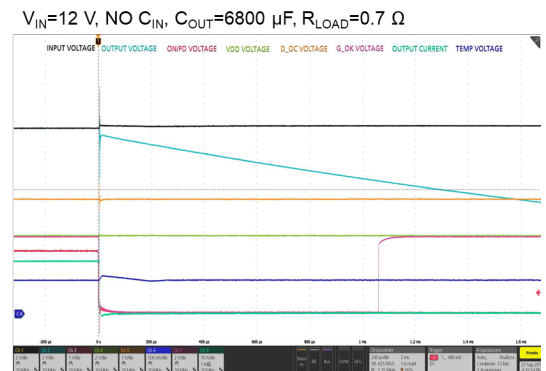
**Figure 27. Shutdown by ON/PD (no load)**



**Figure 28. Start-up by ON/PD ( $I_{OUT} = 15 \text{ A}$ ,  $C_{OUT} = 6800 \mu\text{F}$ )**

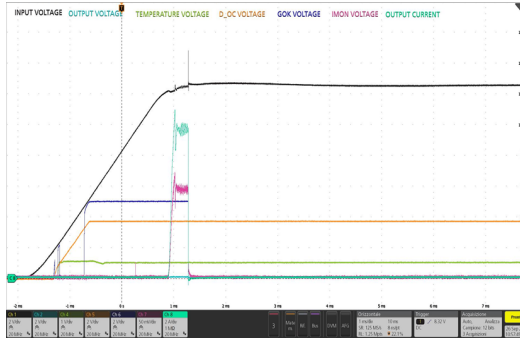


**Figure 29. Shutdown by ON/PD ( $I_{OUT} = 15 \text{ A}$ ,  $C_{OUT} = 6800 \mu\text{F}$ )**



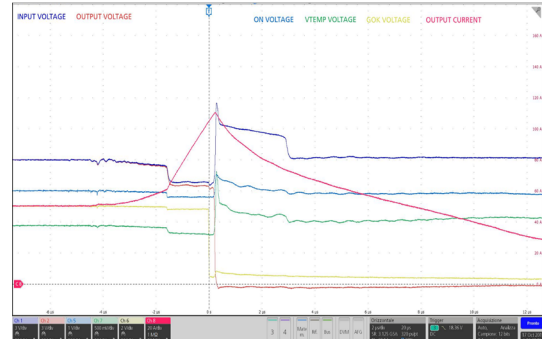
**Figure 30. Start-up into output short-circuit**

$V_{IN} = 12.5\text{ V}$ ,  $C_{ON/PD} = 200\text{ nF}$ , NO  $C_{IN}$ , NO  $C_{OUT}$ ,  $R_{LOAD} = 0\ \Omega$ ,  $GOK = V_{DD}$



**Figure 31. Output short-circuit during operation**

$V_{IN} = 12\text{ V}$ ,  $V_{OUT} = \text{from } 12\text{ V to } 0\text{ V}$ ,  $GOK = 5\text{ V}$ ,  $T_a = 70\text{ }^\circ\text{C}$



## 8 Package information

In order to meet environmental requirements, ST offers these devices in different grades of **ECOPACK** packages, depending on their level of environmental compliance. ECOPACK specifications, grade definitions and product status are available at: [www.st.com](http://www.st.com). ECOPACK is an ST trademark.

### 8.1 VFQFPN (5X5X0.95) 32L package information

Figure 32. VFQFPN (5X5X0.95) 32L package outline

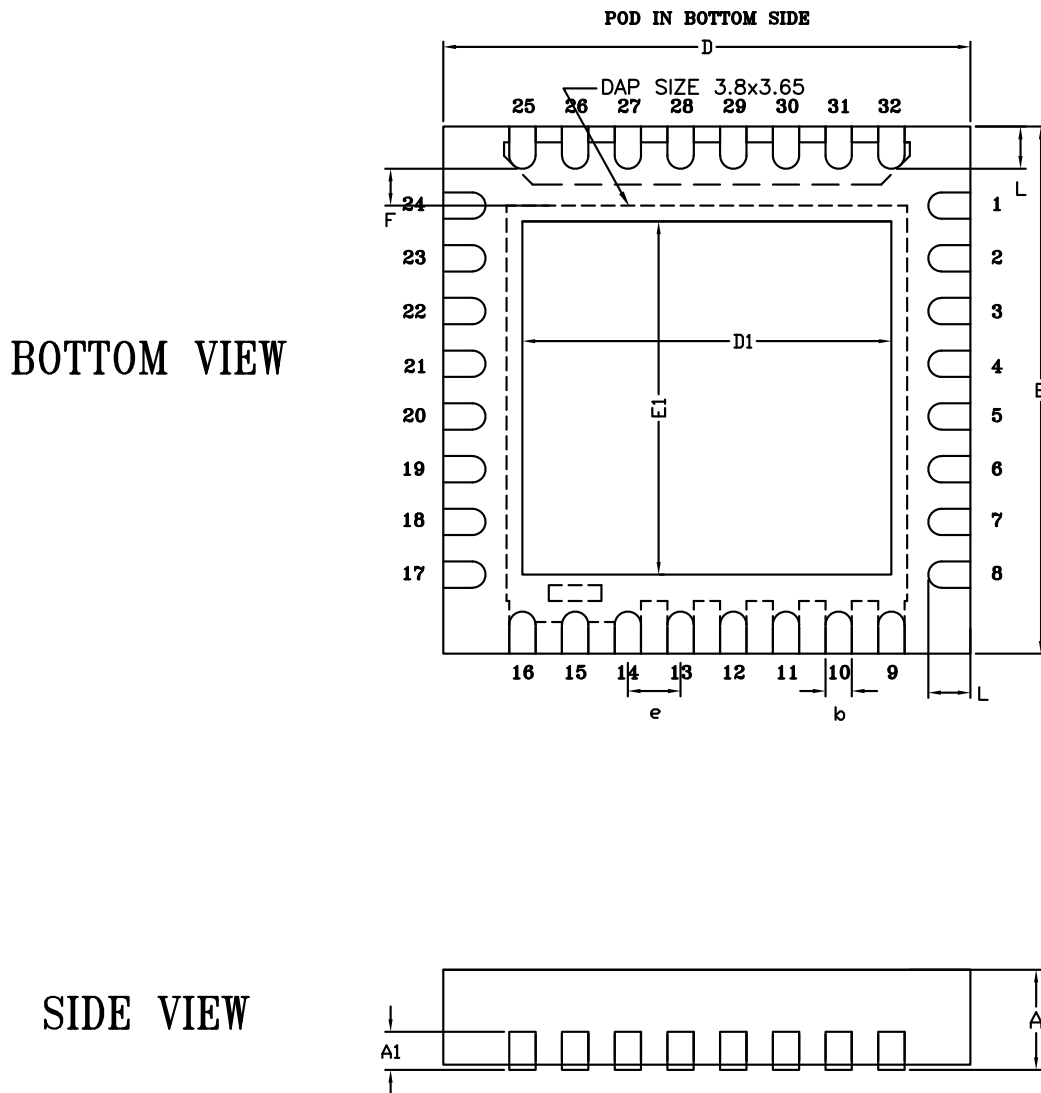
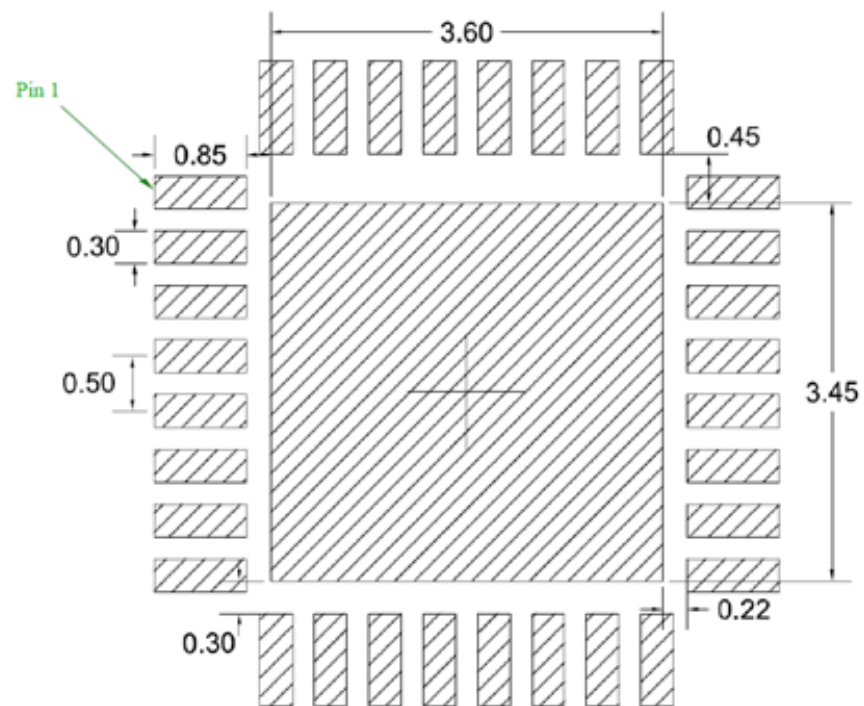


Table 7. VFQFPN (5X5X0.95) 32L package mechanical data

Dim.	mm		
	Min.	Typ.	Max.
A	0.90	0.95	1
A1		0.20	
D	4.90	5.00	5.10
D1	3.40	3.50	3.60
E	4.90	5.00	5.10
E1	3.25	3.35	3.45
e		0.50	
F		0.35	
b	0.20	0.25	0.30
L	0.30	0.40	0.50

Figure 33. VFQFPN (5X5X0.95) 32L recommended footprint





## 8.2 VFQFPN (5X5X0.95) 32L packing information

Figure 34. Carrier tape

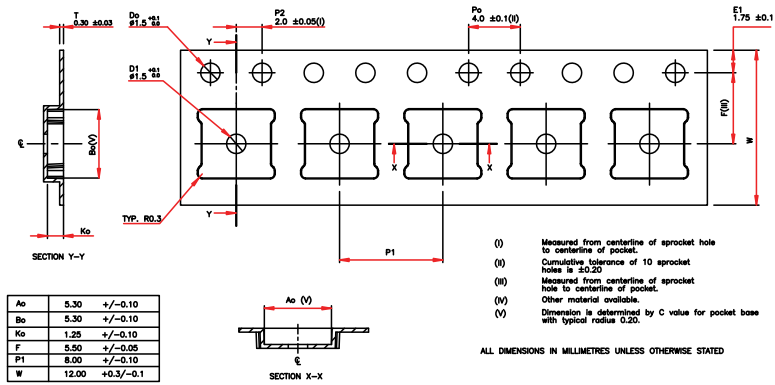


Figure 35. Pin 1 orientation in tape

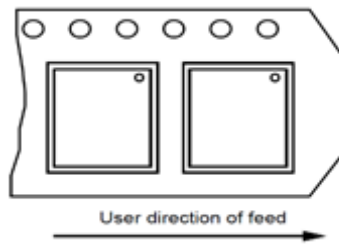


Figure 36. VFQFPN (5X5X0.95) reel outline

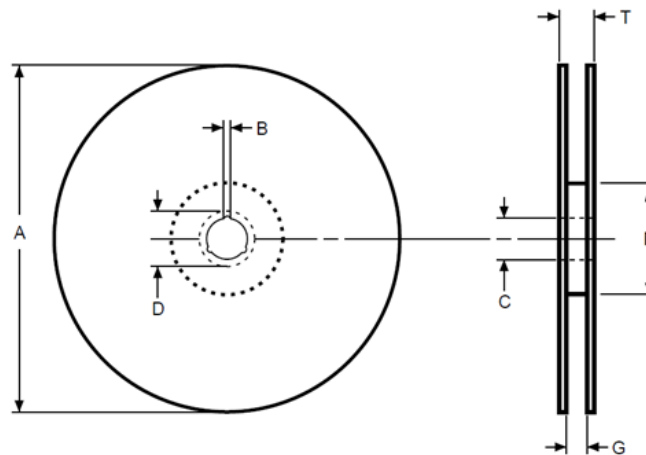


Table 8. VFQFPN (5X5X0.95) reel data

Reel size	Tape width	A (max.)	B (min.)	C	D (min.)	G (max.)	N (min.)	T (max.)	Unit
13"	0.90	330	1.5	13 ± 0.2	20.2	12.6	100	18.4	mm

## 9 Ordering information

**Table 9. Order codes**

Order code	Package	Shutdown mode (latch/auto-retry)	Marking
STEF12H60PUR	VFQFPN (5X5X0.95) 32L	Latch	EF12H60
STEF12H60APUR	VFQFPN (5X5X0.95) 32L	Auto-retry	EF12H60A

## Revision history

**Table 10. Document revision history**

Date	Version	Changes
24-Feb-2020	1	Initial release.
08-May-2020	2	Updated cover page, Table 1. Pin configuration, Table 2. Absolute maximum ratings, Table 4. Recommended operating conditions, Table 5. Electrical characteristics. Updated Section 6 Device functional description, Section 6.3 Soft-start, Section 6.5 Current sensing and current limit.
12-May-2020	3	First public release. Updated Figure 34. Carrier tape.

## Contents

<b>1</b>	<b>Diagram</b> .....	<b>2</b>
<b>2</b>	<b>Pin configuration</b> .....	<b>3</b>
<b>3</b>	<b>Typical application circuit</b> .....	<b>5</b>
<b>4</b>	<b>Absolute maximum ratings</b> .....	<b>7</b>
<b>5</b>	<b>Electrical characteristics</b> .....	<b>9</b>
<b>6</b>	<b>Device functional description</b> .....	<b>13</b>
6.1	UVLO ON/PD function .....	13
6.2	ON/PD function .....	13
6.3	Soft-start .....	13
6.4	Normal operating conditions .....	14
6.5	Current sensing and current limit .....	14
6.6	Current monitor .....	15
6.7	Temperature monitor and thermal shutdown functions .....	16
6.8	Status indicators and fault conditions .....	16
6.9	Diagnostic functions and protections .....	16
6.10	Latch (STEF12H60PUR) and auto-retry versions (STEF12H60APUR) .....	17
<b>7</b>	<b>Typical characteristics</b> .....	<b>18</b>
<b>8</b>	<b>Package information</b> .....	<b>23</b>
8.1	VFQFPN (5X5X0.95) 32L package information .....	23
8.2	VFQFPN (5X5X0.95) 32L packing information .....	25
<b>9</b>	<b>Ordering information</b> .....	<b>26</b>
	<b>Revision history</b> .....	<b>27</b>

## List of tables

<b>Table 1.</b>	Pin configuration . . . . .	3
<b>Table 2.</b>	Absolute maximum ratings . . . . .	7
<b>Table 3.</b>	Thermal data . . . . .	7
<b>Table 4.</b>	Recommended operating conditions . . . . .	8
<b>Table 5.</b>	Electrical characteristics . . . . .	9
<b>Table 6.</b>	Output voltage rise time vs. $C_{SS}$ value ( $V_{IN} = 12\text{ V}$ ) . . . . .	14
<b>Table 7.</b>	VFQFPN (5X5X0.95) 32L package mechanical data . . . . .	24
<b>Table 8.</b>	VFQFPN (5X5X0.95) reel data . . . . .	25
<b>Table 9.</b>	Order codes . . . . .	26
<b>Table 10.</b>	Document revision history . . . . .	27

## List of figures

<b>Figure 1.</b>	Block diagram . . . . .	2
<b>Figure 2.</b>	Pin connection (top view) . . . . .	3
<b>Figure 3.</b>	Typical application diagram (external controller used for CLREF pin) . . . . .	5
<b>Figure 4.</b>	Typical application diagram (current limit fixed via $R_{CL}$ ) . . . . .	6
<b>Figure 5.</b>	Current monitor simplified circuit . . . . .	16
<b>Figure 6.</b>	Quiescent current vs. temperature . . . . .	18
<b>Figure 7.</b>	Shutdown current vs. temperature . . . . .	18
<b>Figure 8.</b>	$I_{MON}$ gain accuracy vs. load current and temperature . . . . .	18
<b>Figure 9.</b>	$I_{MON}$ current vs. load current . . . . .	18
<b>Figure 10.</b>	CS current vs. temperature . . . . .	18
<b>Figure 11.</b>	$V_{CLREF}$ threshold vs. temperature . . . . .	18
<b>Figure 12.</b>	CLREF pin bias current vs. temperature . . . . .	19
<b>Figure 13.</b>	$V_{DD}$ voltage vs. temperature . . . . .	19
<b>Figure 14.</b>	$V_{TEMP}$ voltage vs. temperature . . . . .	19
<b>Figure 15.</b>	UVLO thresholds vs. temperature . . . . .	19
<b>Figure 16.</b>	ON/PD thresholds vs. temperature . . . . .	19
<b>Figure 17.</b>	ON/PD pin current vs. temperature . . . . .	19
<b>Figure 18.</b>	SS pin bias current vs. temperature . . . . .	20
<b>Figure 19.</b>	Turn-on initial delay vs. temperature . . . . .	20
<b>Figure 20.</b>	On-resistance vs. temperature . . . . .	20
<b>Figure 21.</b>	Off-state leakage current vs. temperature . . . . .	20
<b>Figure 22.</b>	Startup by $V_{IN}$ (no load) . . . . .	20
<b>Figure 23.</b>	Shutdown by $V_{IN}$ (no load) . . . . .	20
<b>Figure 24.</b>	Startup by $V_{IN}$ ( $C_{OUT} = 6200 \mu F$ , no load) . . . . .	21
<b>Figure 25.</b>	Startup by $V_{IN}$ ( $C_{OUT} = 6200 \mu F$ , 15 A, res. load) . . . . .	21
<b>Figure 26.</b>	Startup by ON/PD (no load) . . . . .	21
<b>Figure 27.</b>	Shutdown by ON/PD (no load) . . . . .	21
<b>Figure 28.</b>	Start-up by ON/PD ( $I_{OUT} = 15 A$ , $C_{OUT} = 6800 \mu F$ ) . . . . .	21
<b>Figure 29.</b>	Shutdown by ON/PD ( $I_{OUT} = 15 A$ , $C_{OUT} = 6800 \mu F$ ) . . . . .	21
<b>Figure 30.</b>	Start-up into output short-circuit . . . . .	22
<b>Figure 31.</b>	Output short-circuit during operation . . . . .	22
<b>Figure 32.</b>	VFQFPN (5X5X0.95) 32L package outline . . . . .	23
<b>Figure 33.</b>	VFQFPN (5X5X0.95) 32L recommended footprint . . . . .	24
<b>Figure 34.</b>	Carrier tape . . . . .	25
<b>Figure 35.</b>	Pin 1 orientation in tape . . . . .	25
<b>Figure 36.</b>	VFQFPN (5X5X0.95) reel outline . . . . .	25

**IMPORTANT NOTICE – PLEASE READ CAREFULLY**

STMicroelectronics NV and its subsidiaries (“ST”) reserve the right to make changes, corrections, enhancements, modifications, and improvements to ST products and/or to this document at any time without notice. Purchasers should obtain the latest relevant information on ST products before placing orders. ST products are sold pursuant to ST’s terms and conditions of sale in place at the time of order acknowledgement.

Purchasers are solely responsible for the choice, selection, and use of ST products and ST assumes no liability for application assistance or the design of Purchasers’ products.

No license, express or implied, to any intellectual property right is granted by ST herein.

Resale of ST products with provisions different from the information set forth herein shall void any warranty granted by ST for such product.

ST and the ST logo are trademarks of ST. For additional information about ST trademarks, please refer to [www.st.com/trademarks](http://www.st.com/trademarks). All other product or service names are the property of their respective owners.

Information in this document supersedes and replaces information previously supplied in any prior versions of this document.

© 2020 STMicroelectronics – All rights reserved