

# SERPAC A-20

Electronics Enclosures

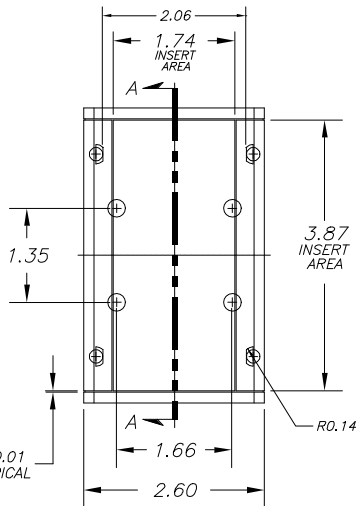

NOTES:  
1. WHEN MACHINE OR I PLATES MODIFICATIONS ARE REQUIRED, USE THE CENTER OF THE BOX TO DIMENSION.

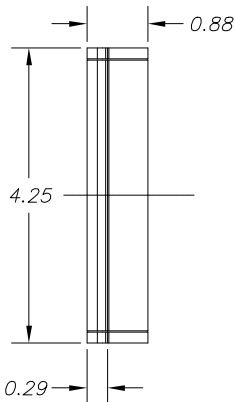
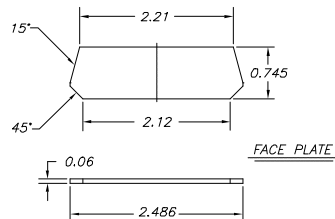
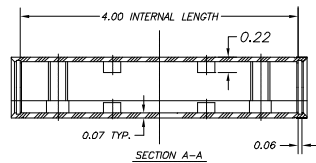
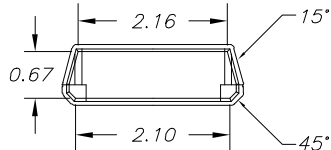
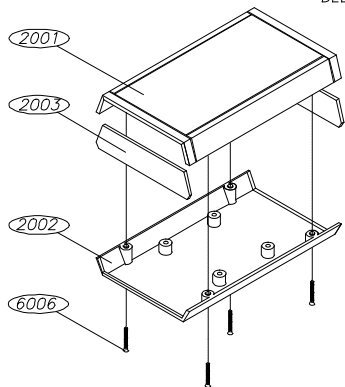
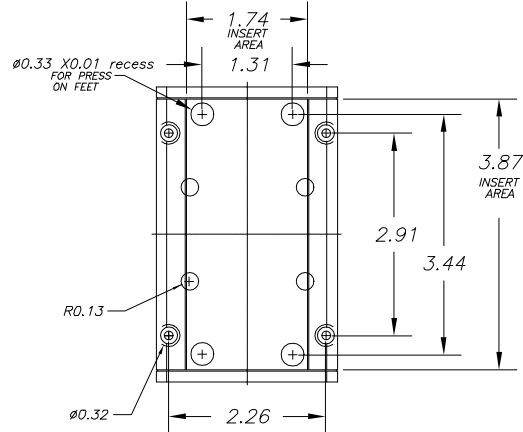

10-07-98

ALL DIMENSIONS ± .010

PART NO.	DESCRIPTION	PART NO.	ACCESSORIES
2001	PLASTIC TOP	52	PRESS ON FEET
2003	PLASTIC END PANEL	2003IR	INFRARED PANELS
2002	PLASTIC BOTTOM	2003CL	CLEAR & TRANSPARENT RED PANELS
6006	SCREW	2003DB9	9 PIN CONNECTOR
		2003DB25	25 PIN CONNECTOR
		PC	POCKET CLIP