

METTEC DOUBLE EUROCARD CASES

Designed to accept double DIN 41612 Eurocards 233.4 x 160 mm and 233.4 x 220 mm in five horizontal positions.

ASSEMBLY

Very robust construction in aluminium assembled by four M4 screws. The side extrusions also incorporate enclosed vertical guide positions for hidden components and devices. For high shielding attenuation all internal parts are masked and interlock with each other. The front panel mounting face on the bezel is also masked for electrical contact.

All cases are supplied assembled and include the fixings for the accessory front panels and four non-slip self-adhesive feet.

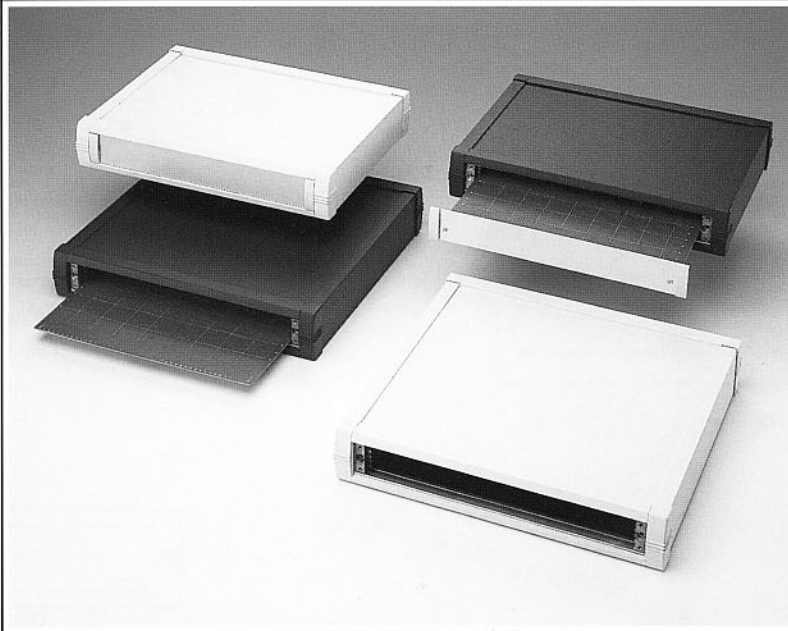

ACCESSORIES

FRONT PANEL KIT:

Supplied with two trims which hide the fixing screws and allow easy assembly of membrane keyboards.

EUROCARD MOUNTING KIT:

For mounting a Eurocard to the front panel. Mounting details see page 26.

SUPPLY

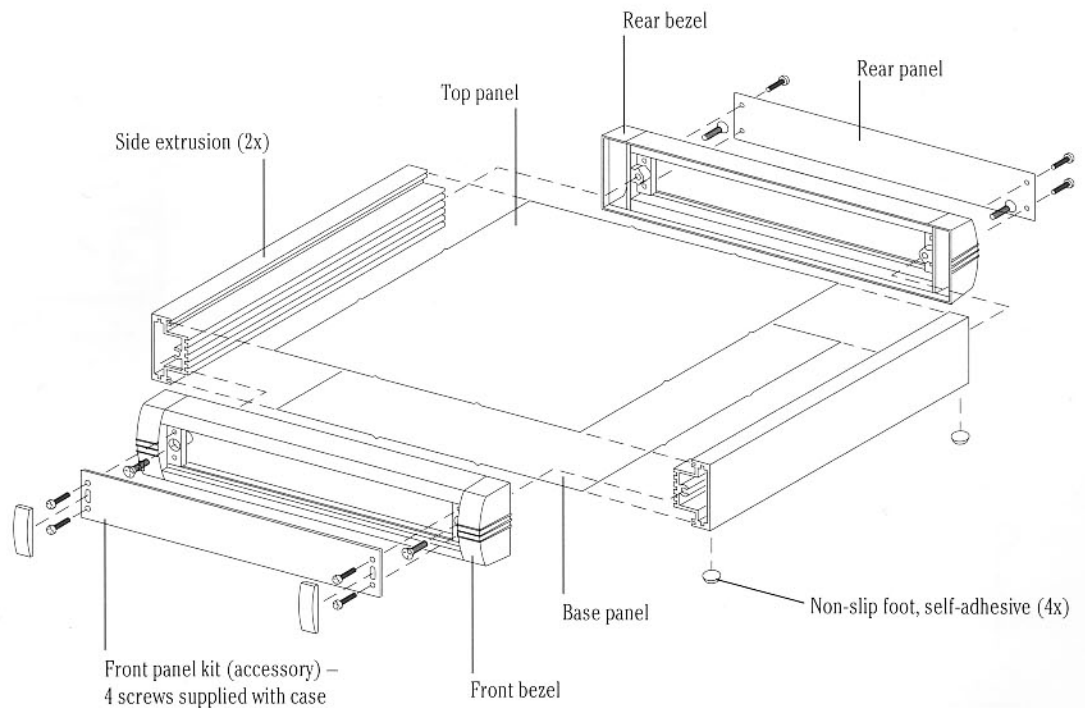

Part No.		METTEC DOUBLE EUROCARD CASES						
anthracite	off-white	For Eurocard...	Outside dim. in mm			Inside dim. in mm		
			Height	Width	Depth	a	b	c
M 57 27 054	M 57 27 057	233.4 x 160 mm	50	286	220	180	206.5	190
M 57 28 054	M 57 28 057	233.4 x 220 mm	50	286	280	240	266.5	250
		ACCESSORIES						
Article		Application / Supply						
M 57 00 623		Front panel kit						
M 57 00 017		Eurocard mounting kit						

METTEC DOUBLE EUROCARD CASES

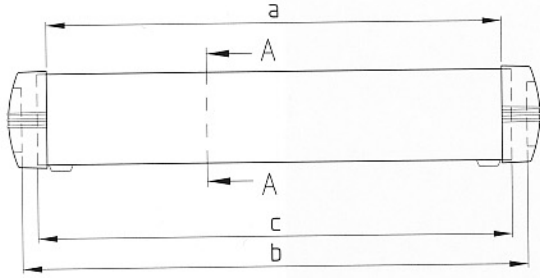

Side View

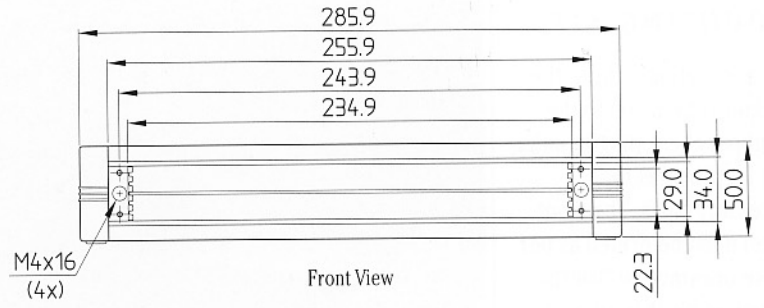

Front View

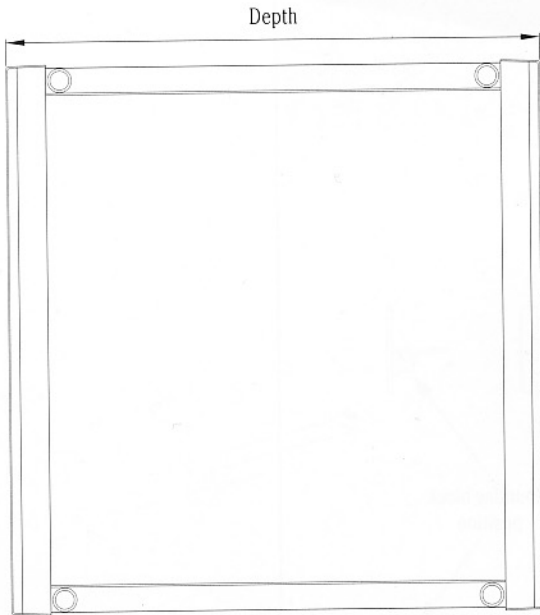

Base View

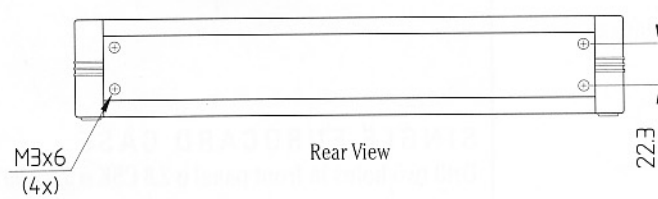

Rear View

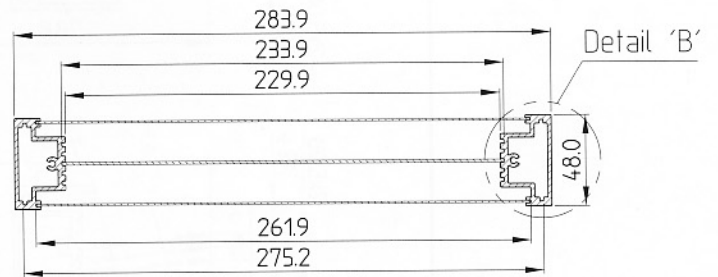

A-A

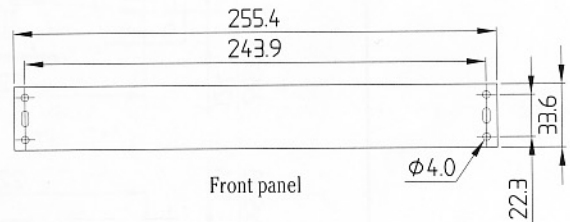
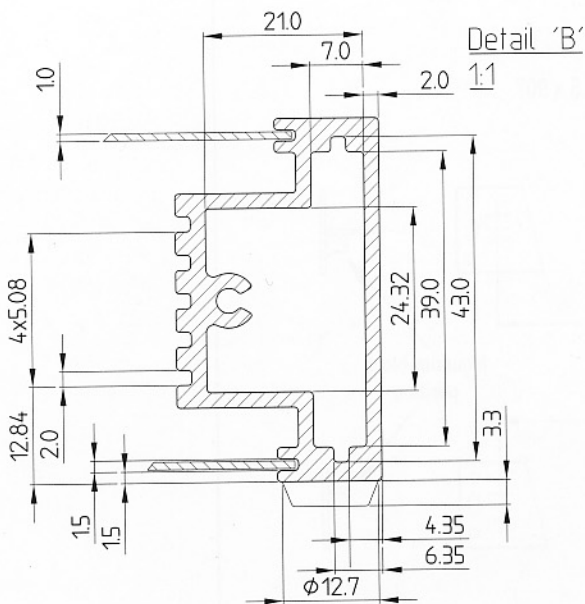

Front panel