

Bias supply DC-DC

KIT_6W_13V_P7_950V

Auxiliary supply solution featuring off-line SMPS current mode controller IC with 950 V CoolMOS™ P7 SJ MOSFET



Description

KIT_6W_13V_P7_950V



Ordering code:
KIT_6W_13V_P7_950V

Board components

- › CoolSET™ 5th gen. Stand-alone controller (ICE5QSAG)
- › 950V CoolMOS™ P7 SJ MOSFET (IPU95R3K7P7)

Board specifications

- › Input voltage: $90V_{DC} - 440 V_{DC}$
- › Output voltage: $13V_{DC}$ (pri. + sec. side)
- › Output power max.: 6W (pri. + sec. side)

Technical Parameter

KIT_6W_13V_P7_950V



Summary

Quasi-resonant flyback using a Infineon's fifth generation controller.

-Snubberless operation to improve efficiency, 950V breakdown voltage allows operating off of higher input voltages.

Primary side regulated 18V and a secondary side unregulated 13V output.

In power supplies that are used for server, telecom, and industrial applications there is typically a small bias power supply in addition to the main power converter. This 6W bias board is designed to run in a system where it is continuously powered from the 400V_{DC} output of a boost power factor correction (PFC) converter and provides power to fans, gatedrivers, and controllers. This board uses the ICE5QSAG quasi-resonant (QR) flyback controller and the new 950V CoolMOS™ P7 (IPU95R3K7P7). This 950V breakdown voltage gives additional margin in the system to ensure the bias continues to run through surge events. This design was done as a snubberless flyback converter to further improve the efficiency over the entire load range.

Description	Value
Max. Efficiency [%]	85
Max. Efficiency [%] @ Output Current [A]	0.35
Max. Efficiency [%] @ Input Voltage [V]	400
Nom. Efficiency [%]	85
Efficiency @ 10% load [%]	50
Efficiency @ 50% load [%]	85
Efficiency @ 100% load [%]	85
Switching frequency min [kHz]	25
Switching frequency max [kHz]	60
Input Voltage Type	DC
Input Voltage min [V]	90
Input Voltage nom [V]	380
Input Voltage max [V]	440

ICE5QSAG

Description:

- › Infineon latest 5th generation quasi-resonant flyback PWM controller offers high performance and comprehensive suite of protection to increase system robustness.

Summary of Features:

- › Novel quasi-resonant switching scheme
- › Rapid and adjustable start-up with cascode configuration
- › 2 level selectable active burst mode level
- › Built-in digital soft-start
- › Cycle by cycle peak current limitation
- › Digital frequency reduction with decreasing load for higher efficiency
- › Adjustable line input over-voltage and brown IN/OUT protection
- › V_{CC} and CS pin short to ground protection
- › OLP, output short, output over-voltage, OTP with hysteresis and V_{CC} over/under voltage protection
- › Auto-restart for all protection features



Benefits:

- › High efficiency with latest CoolMOS™ P7 SJ MOSFET family and quasi-resonant switching scheme
- › Auto-restart recovery scheme to minimize interruption to system operation
- › Extensive protection coverage to increase system robustness
- › Rapid start-up performance with cascode configuration

IPU95R3K7P7

Description:

- › Designed to meet the growing consumer needs in the high voltage MOSFETs arena, the latest 950V CoolMOS™ P7 technology focuses on the low-power SMPS market.

Summary of Features:

- › Offering 50V more blocking voltage than its predecessor 900V CoolMOS™ C3, the 950V CoolMOS™ P7 series delivers outstanding performance in terms of efficiency, thermal behavior and ease-of-use. As the all other P7 family members, the 950V CoolMOS™ P7 series comes with an integrated Zener diode ESD protection. The integrated diode considerably improves ESD robustness, thus reducing ESD-related yield loss and reaching exceptional ease-of-use levels. CoolMOS™ P7 is developed with best-in-class VGS(th) of 3V and a narrow tolerance of only $\pm 0.5V$, which makes it easy to drive and design-in.



Schematic

KIT_6W_13V_P7_950V

Vin: 90Vdc-440Vdc

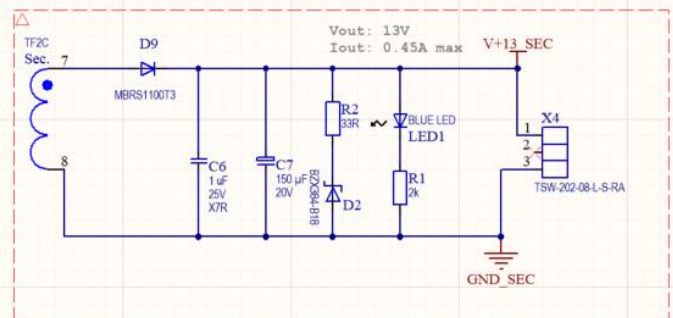
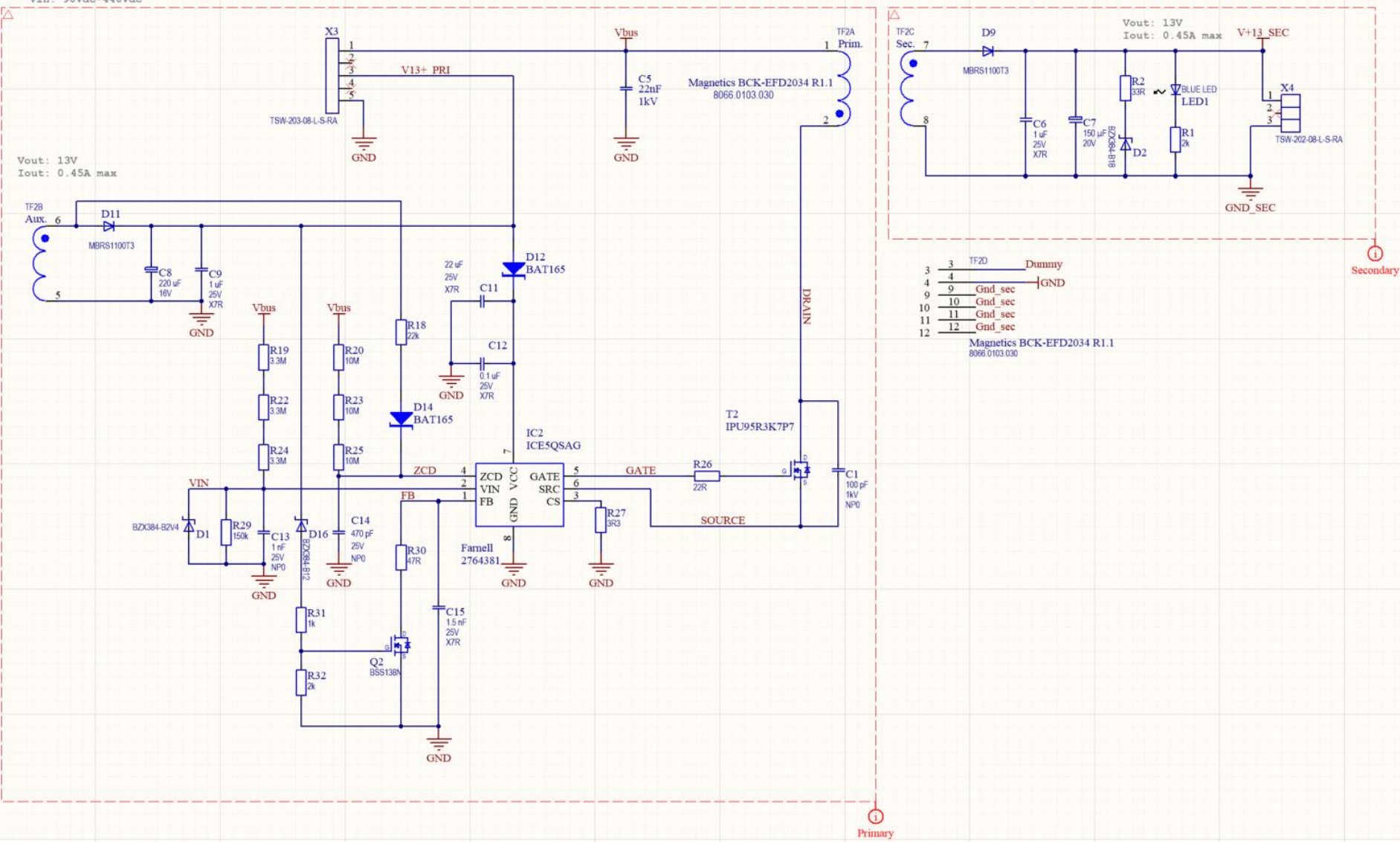

3	3	TF2D	Dummy
4	4		GND
9	9	Gnd_sec	
10	10	Gnd_sec	
11	11	Gnd_sec	
12	12	Gnd_sec	

Magnetics BCK-EFD2034 R1.1
8066 0103.030

Secondary

Primary

Transformer

KIT_6W_13V_P7_950V

AVV. Wind.	CONDUTTORE Wire	Nr. SPIRE Nr. of turns	R P t g z	PIN DI USCITA Pin output	SPIRE STRATO Turns per layer	Nr. STRATI Nr. of layers	NOTE Remarks
N1	Filo rame Ø0,15 Rif.4	0 65	+	2 3	56	2	ESEGUIRE 1 GIRO DI SPONDIRA H=3MM RIF.9 LATO 7-12 Execute 1 turn of tape h=3mm ref.9 side 7-12
ISOLAMENTO: 2		GIRI DI NASTRO ADESIVO POLIESTERE RIF. turns of polyester adhesive tape Ref.			7		
N2	TEX-E050 Rif.5	0 10	+	7 8	10	1	ATTRAVERSAMENTO A 90° SU NASTRO LATERALMENTE Perpendicular crossing on tape
ISOLAMENTO: 2		GIRI DI NASTRO ADESIVO POLIESTERE RIF. turns of polyester adhesive tape Ref.			7		
N3	Filo rame Ø0,50 Rif.6	0 10	+	6 5	10	1	LASCIARE 3MM LATO 7-12 ATTRAVERSAMENTO A 90° SU NASTRO LATERALMENTE Leave 3mm side 7-12. Perpendicular crossing on tape
ISOLAMENTO: 2		GIRI DI NASTRO ADESIVO POLIESTERE RIF. turns of polyester adhesive tape Ref.			7		
N4	Filo rame Ø0,15 Rif.4	0 65	+	3 1	46	2	ESEGUIRE 1 GIRO DI SPONDIRA H=3MM RIF.9 LATO 7-12 E 1 GIRO DI SPONDIRA H=1MM RIF.8 LATO 1-6 Execute 1 turn of tape H=3mm ref.9 side 7-12 and 1 turn of tape H=1mm ref.8 side 1-6
ISOLAMENTO: 2		GIRI DI NASTRO ADESIVO POLIESTERE RIF. turns of polyester adhesive tape Ref.			7		
<p>POSIZIONAMENTO ROCCHETTO Positioning of the coilformer</p>				<p>PIEDINATURA (VISTA DAL BASSO) Pin-out (bottom view)</p>			
<p>SCHEMA ELETTRICO Electrical diagram</p>							

MONTAGGIO – Assembling																																
<p>APPLICARE NR.2 PIASTRINI ISOLANTI RIF.11 Apply nr.2 spacers ref.11</p>																																
<p>ASSEMBLARE I SEMINUCLEI MEDIANTE 2 GIRI DI NASTRO RIF.10 Fix the halfcores with 2 turns of tape ref.10</p>																																
<p>BLOCCARE NUCLEO/NUCLEO E ROCCHETTO/NUCLEO MEDIANTE RIF.15+16 Fix core/core and coil/core with ref.15+16</p>																																
<p>TAGLIARE PIN 3 DOPO LA SALDATURA cut pin 3 after soldering</p>																																
<p>2011/65/UE (RoHS-2) Compliant</p> <p style="text-align: right;">DIMENSIONI IN MILLIMETRI Dimensions in millimeters</p>																																
COLLAUDO ELETTRICO – Electrical checking																																
TIPO DI PROVA – Test	CONDIZIONI DI PROVA – Test Conditions	LIMITI – Limits																														
INDUTTANZA Inductance	2-1 @ 10 kHz – 100 mV	4.25 ÷ 5.75 mH																														
RAPPORTO SPIRE Turns ratio	TRA TUTTI GLI AVV. @ 10kHz – 100mV Between all windings	< 1 SPIRA Turn																														
RIGIDITA' DIELETTRICA Dielectric strength	2+1+6+5/7+8 @ 4200 V – 50 Hz – 2 sec.	SUPERARE LA PROVA pass the test																														
RIGIDITA' DIELETTRICA Dielectric strength	2+1/6+5 @ 300 V – 50 Hz – 2 sec.	SUPERARE LA PROVA pass the test																														
INDUTTANZA DISPERSA Leakage inductance	2-1 @ 10 kHz – 100 mV – 5+6+7+8 c.c.	< 40 µH																														
<p>I. C. E.</p> <table border="1"> <tr> <td>01</td> <td>30.06.17</td> <td></td> <td>EMISSIONE – Release</td> <td>C. Piccirilli</td> <td>D. Di Giorgio</td> </tr> <tr> <td>REV</td> <td>DATA APPR</td> <td>RIF. MOD.</td> <td>DESCRIZIONE MODIFICA</td> <td>REDAZIONE</td> <td>VERIFICA E APPROVAZIONE</td> </tr> <tr> <td>Rev</td> <td>Appr. Date</td> <td>Ref. Mod.</td> <td>Description of modification</td> <td>Editing</td> <td>Check and approval</td> </tr> </table> <p>TRANSFORMERS DESCRIZIONE-Description Transformer EFD20 SMD (6W_BIAS_V2)</p> <table border="1"> <tr> <td>Mod.</td> <td>DOCUMENTO-Document</td> <td>CODICE-Part Number</td> <td>REV.-Revision</td> <td>DATA EMISSIONE-Release date</td> <td>PAG.-Page</td> </tr> <tr> <td>AQ 05.09</td> <td>P.F.</td> <td>8066.0103.030</td> <td>01</td> <td>30.06.17</td> <td>1/1</td> </tr> </table>			01	30.06.17		EMISSIONE – Release	C. Piccirilli	D. Di Giorgio	REV	DATA APPR	RIF. MOD.	DESCRIZIONE MODIFICA	REDAZIONE	VERIFICA E APPROVAZIONE	Rev	Appr. Date	Ref. Mod.	Description of modification	Editing	Check and approval	Mod.	DOCUMENTO-Document	CODICE-Part Number	REV.-Revision	DATA EMISSIONE-Release date	PAG.-Page	AQ 05.09	P.F.	8066.0103.030	01	30.06.17	1/1
01	30.06.17		EMISSIONE – Release	C. Piccirilli	D. Di Giorgio																											
REV	DATA APPR	RIF. MOD.	DESCRIZIONE MODIFICA	REDAZIONE	VERIFICA E APPROVAZIONE																											
Rev	Appr. Date	Ref. Mod.	Description of modification	Editing	Check and approval																											
Mod.	DOCUMENTO-Document	CODICE-Part Number	REV.-Revision	DATA EMISSIONE-Release date	PAG.-Page																											
AQ 05.09	P.F.	8066.0103.030	01	30.06.17	1/1																											

Base board KIT_6W_13V_P7_950V



**Ordering code:
KIT_6W_13V_P7_950V**

Auxiliary supply solution featuring off-line SMPS current mode controller IC with an 950 V CoolMOS™ SJ MOSFET

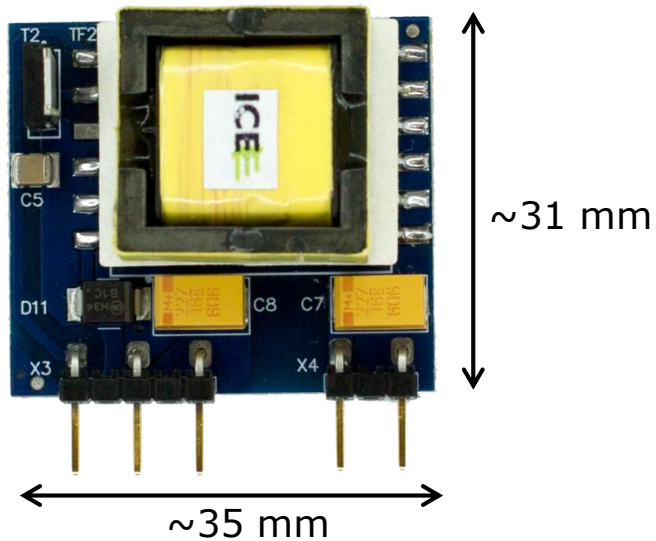



Technical Material

- > Application Notes
- > Simulation Models
- > Datasheets
- > PCB Design Data

> www.infineon.com/kit-6w-13v-p7-950

Evaluation Boards

- > Evaluation Boards
- > Demoboards
- > Reference Designs

> www.infineon.com/evaluationboards

Videos

- > Technical Videos
- > Product Information Videos

> www.infineon.com/mediacenter

Support Online tools and services



The screenshot shows the Infineon website's navigation menu with the following items: Products, Applications, Tools (highlighted with a red box and a '3' in a circle), About Infineon, and Careers. In the top right corner, there are links for Newsletter (highlighted with a red box and a '1' in a circle), Contact, Where to Buy (highlighted with a red box and a '2' in a circle), English, and Login. A search bar is also present. The main content area features a 'Lighting' banner with a city skyline at night. The banner text reads: 'Lighting', 'New LED controller enables low-wattage luminaire designs', 'August 26th 17:00 CEST', and a 'Register Now!' button. A '4' in a circle is positioned near the 'Support' link in the navigation menu.

- 1 **Subscribe to Newsletter**
- 2 **Where to Buy**
- 3 **Tools, Finders and Selectors**
- 4 **Support**

- Products
 - Applications
 - Tools
 - Support (highlighted with a red box and a '4' in a circle)
 - Technology
- Power
 - Automotive System IC
 - ESD & EMI
 - Microcontroller
 - RF & Wireless Control
 - Security IC
 - Sensor
 - Smart Card IC
 - Interface
 - Transistor & Diode
 - Power Overview
 - Power MOSFET
 - IGBT
 - Smart Low-Side & High-Side Switches
 - Linear Voltage Regulator
 - DC-DC Converter
 - LED Driver | Lighting ICs
 - Silicon Carbide (SiC)
 - High Power Thyristors & Diodes
 - Motor Control & Gate Driver
 - AC-DC Supply

News & Tweets



Part of your life. Part of tomorrow.

