

NEW

0.5mm Pitch, 3.57mm depth One Action Lock, Vertical connection FPC/FFC/Shield FFC connector

FH67 Series

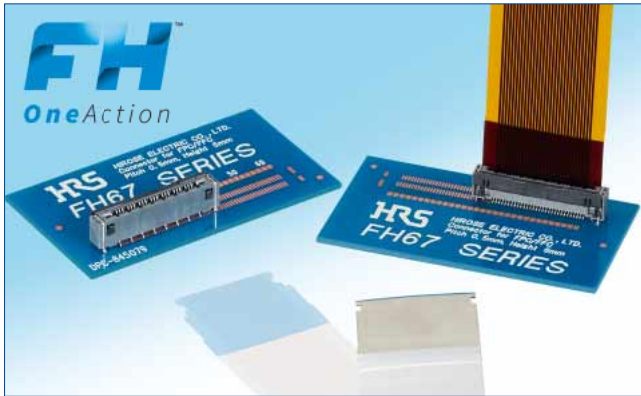

One Action Lock (Dimension diagram : 30pos.)

Insert FPC/FFC without opening the lock lever before insertion!

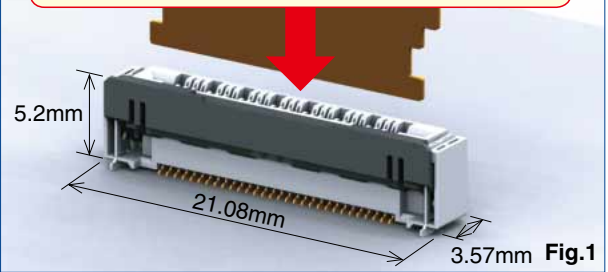

Features

1. Automatic one action lock design

One action locking by simply inserting FPC after mounting contributes to enhanced workability. (Fig.1) (Lock release by operating the lock lever when removing.)

- Operation of the lock lever is not required at the time of mating FPC. Can be inserted with one hand. Contributes to reduced assembly time.
- The lock lever will not be damaged by operation. Mating failure due to FPC displacement does not occur during lock lever operation.

2. Two-point contact prevents contact failure by dust

- High contact reliability by independent spring two-point contact design, preventing contact failure due to dust. (Fig.2)

3. Supports FPC/FFC/Shield FFC

- FH67 allows you to choose from FPC/FFC/Shield FFC.
- Shielded FFC is acceptable for EMI prevention. (Fig.3)

4. High FPC retention force

- The circuit is automatically locked after FPC/FFC is inserted by a one action. The notches on both sides of FPC are held by the lock lever, generating a high FPC retention force in spite of the small contact. (Fig.4)

5. Visual inspection on the mated status of FPC/FFC is possible

- Insufficient insertion during assembly is prevented due to lock lever protrusion after FPC/FFC insertion. (Fig.5)

6. Environmental

- Halogen free
- *As defined by IEC 61249-2-21.
- Br : 900ppm max, Cl : 900ppm max, Br+Cl : 1,500ppm max

Two-point contact design for dust prevention

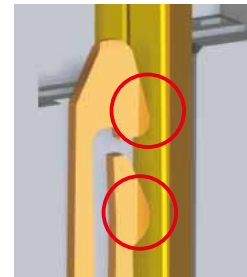

Two-point independent spring contact Fig.2

Supports FPC/FFC/Shield FFC

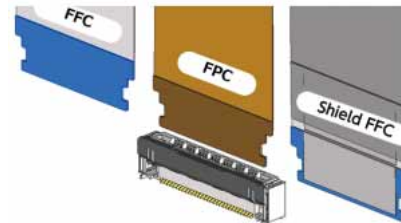

Shielded FFC is acceptable for EMI prevention

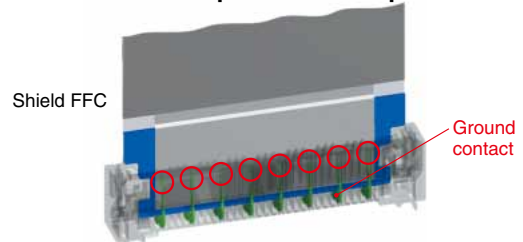

Ground contact and FFC Ground plate contact at multiple points. Fig.3

FPC/FFC can be checked from the top surface after mating.

○ : Mated condition × : Insufficient insertion condition

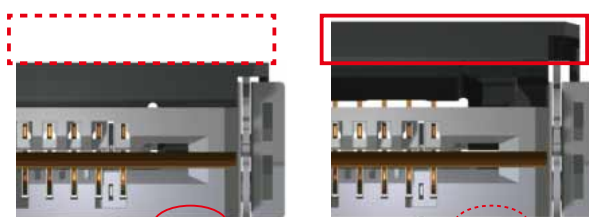

Viewing section Cannot see viewing section Fig.5

High FPC retention force

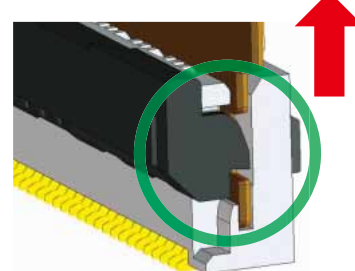

Robust lock firmly retains FPC/FFC. Fig.4

Product Specifications

Rating	Rated Current	0.5A	Operating temperature range	-55 to +125°C (Note 1)	Storage temperature range	-10 to +60°C (Note 2)
	Rated voltage	50V AC/DC	Operating humidity range	Relative humidity 90% max. (No condensation)	Storage humidity range	Relative humidity 90% max. (No condensation)

Adaptive FPC contact specifications	Thickness : = 0.33 ± 0.03mm Signal layout : Gold plated, GND plate : Tin plated
-------------------------------------	---

Item	Specification	Condition
1. Insulation resistance	500MΩ min.	100V DC
2. Withstanding voltage	No flashover or insulation breakdown	150V AC rms / 1minute
3. Contact resistance	[FPC] First cycle : 60mΩ max., After testing : 80mΩ max. (Including FPC 8mm conductor resistance) [FFC] First cycle : 80mΩ max. After testing : 100mΩ max. (Including FFC 26mm conductor resistance)	1mA AC
4. Durability (Insertion/withdrawal)	Contact resistance : 80mΩ max. (FPC) 100mΩ max. (FFC) No damage, cracks, or parts dislocation	10 cycles
5. Vibration	No electrical discontinuity of 1μs or more Contact resistance : 80mΩ max. (FPC) 100mΩ max (FFC) No damage, cracks, or parts dislocation	Frequency : 10 to 55Hz, single amplitude of 0.75mm, 10 cycles in each of the 3 directions
6. Shock	No electrical discontinuity of 1μs or more Contact resistance : 80mΩ max.(FPC) 100mΩ max.(FFC) No damage, cracks, or parts dislocation	Acceleration of 981m/s ² , duration of 6 ms, sine half-wave waveform, 3 cycles in each of the 3 axes
7. Damp heat (Steady state)	Contact resistance : 80mΩ max.(FPC) 100mΩ max.(FFC) Insulation resistance : 50MΩ min. No damage, cracks, or parts dislocation	96 hours at temperature of 60°C and humidity of 90% to 95%
8. Temperature cycle	Contact resistance : 80mΩ max.(FPC) 100mΩ max.(FFC) Insulation resistance : 50MΩ min. No damage, cracks, or parts dislocation	Temperature : -55 → +15 to +35 → +125 → +15 to +35°C Time : 30 → 2 to 3 → 30 → 2 to 3 (Minutes) 5 cycles
9. Resistance to soldering heat	No deformation of components affecting performance	Reflow : Recommended Temperature Profile Manual soldering : 350 ± 10°C for 5 seconds

Note 1 : Includes temperature rise caused by current flow.

Note 2 : The term "storage" refers to products stored for long period of time prior to mounting and use. Operating Temperature Range and Humidity Range covers non-conducting condition of installed connectors in storage, shipment or during transportation.

Materials / Finish

Part	Materials	Finish	UL standard
Insulator	LCP	Grey	UL94V-0
	LCP	Black	
Signal contact	Copper alloy	Nickel barrier gold plated	—
Ground contact	Copper alloy	Pure tin reflow plated	—
Reinforcing metal tabs	Copper alloy	Pure tin reflow plated	—

Product Number Structure

Refer to the chart below when determining the product specifications from the product number. Please select from the product numbers listed in this catalog when placing orders.

FH 67 – 30S – 0.5 SV (99)

① ② ③ ④ ⑤ ⑥

① Series Name : FH	⑤ Terminal type SV...SMT vertical mounting type
② Series No. : 67	
③ No. of Contacts : 30	
④ Contact Pitch : 0.5mm	
⑥ Specification Blank : Standard 1,000pcs/reel (99) : 500pcs/reel	

Connector Dimensions

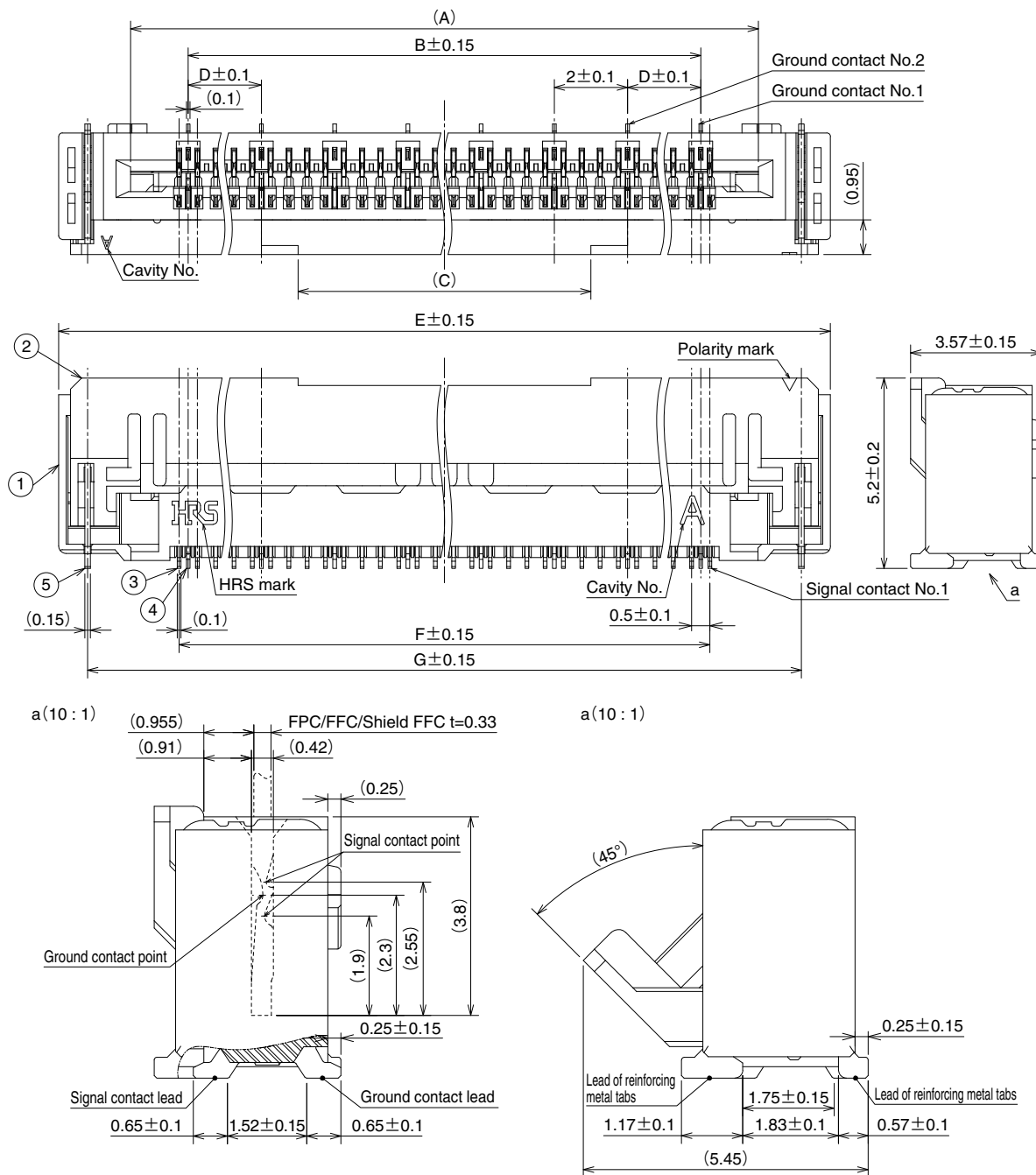

Note

- 1 : The dimension in parentheses are for reference.
- 2 : Lead co-planarity including lead of reinforcing metal tabs shall be 0.1mm max.
- 3 : To be delivered with tape and reel packages.
See the packaging specifications for details.
- 4 : Note that preventive hole for sink mark or slit could be added for improvement.
- 5 : The quality remains good, even with the dark spots, which could occasionally occur on molded plastic.
- 6 : This product satisfies halogen free requirements defined as 900ppm maximum chlorine, 900ppm maximum bromine, and 1500ppm maximum total of chlorine and bromine.

Unit : mm

Part No.	HRS No.	No. of Contacts	A	B	C	D	E	F	G
FH67-10S-0.5SV	Under planning (Note 1)	10	7.15	4	5	2	11.08	4.5	9.5
FH67-20S-0.5SV	Under planning (Note 1)	20	12.15	9	7.5	1.5	16.08	9.5	14.5
FH67-30S-0.5SV	580-4901-0 **	30	17.15	14	8	2	21.08	14.5	19.5
FH67-40S-0.5SV	580-4903-0 **	40	22.15	19	8	1.5	26.08	19.5	24.5

Note 1 : Contact positions without HRS No. are currently under planning.
Please contact HRS for detailed information about product variations.

Recommended PCB Mounting Pattern

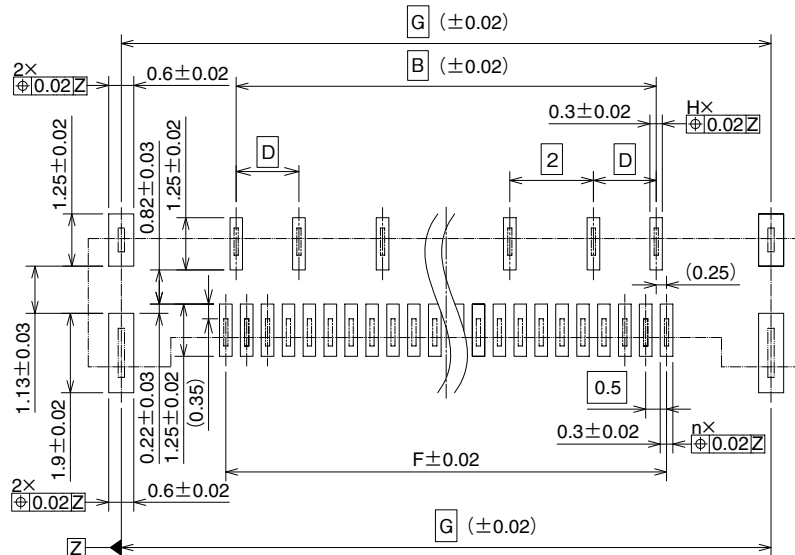

Recommended Stencil Pattern

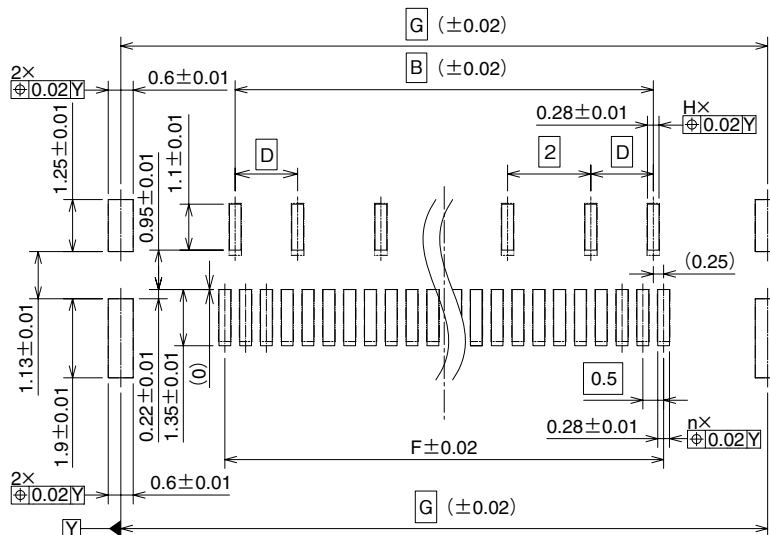

Note 7 : 'n' shows the number of contacts.

Recommended Dimensions of PCB Mounting Pattern and Stencil Pattern

Unit : mm

Part No.	HRS No.	No. of Contacts	B	D	E	G	H
FH67-10S-0.5SV	Under planning (Note 1)	10	4	2	11.08	9.5	3
FH67-20S-0.5SV	Under planning (Note 1)	20	9	1.5	16.08	14.5	6
FH67-30S-0.5SV	580-4901-0 **	30	14	2	21.08	19.5	8
FH67-40S-0.5SV	580-4903-0 **	40	19	1.5	26.08	24.5	11

Note 1 : Contact positions without HRS No. are currently under planning.
Please contact HRS for detailed information about product variations.

◆ Recommended FPC/FFC Dimensions

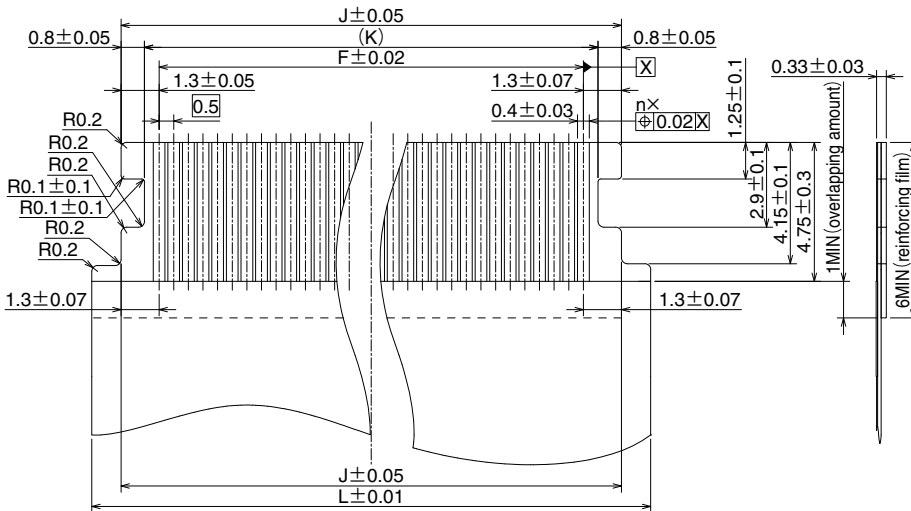

◆ Recommended Shield FFC Dimensions

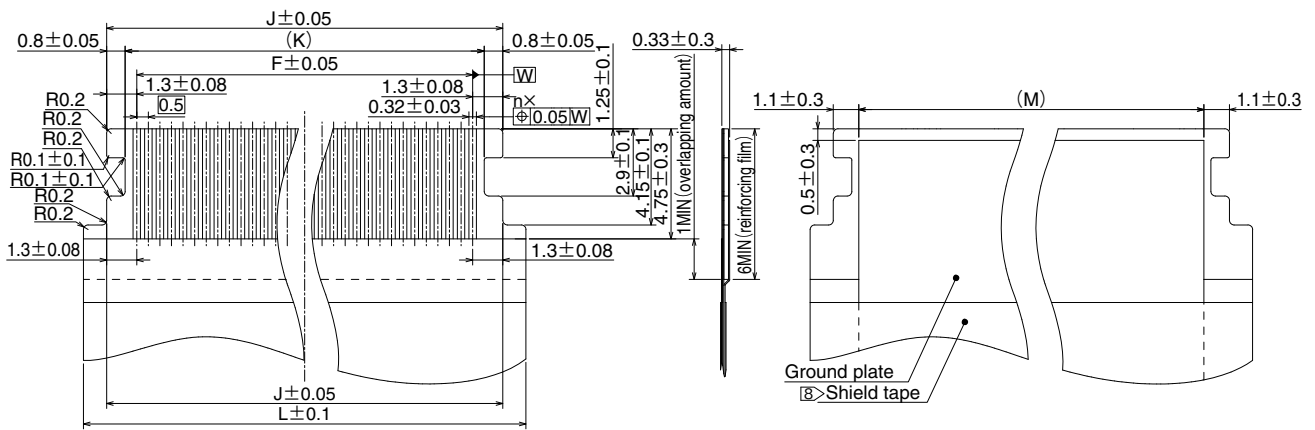

Note 7 : The value 'n' indicates the number of pos.

[Symbol] Overlap the shield on the grounding plate.

◆ Recommended Dimensions of FPC/FFC/Shield FFC

Unit : mm

Part No.	HRS No.	No. of Contacts	F	J	K	L	M
FH67-10S-0.5SV	Under planning (Note 1)	10	4.5	7.1	5.5	9.1	4.9
FH67-20S-0.5SV	Under planning (Note 1)	20	9.5	12.1	10.5	14.1	9.9
FH67-30S-0.5SV	580-4901-0 **	30	14.5	17.1	15.5	19.1	14.9
FH67-40S-0.5SV	580-4903-0 **	40	19.5	22.1	20.5	24.1	19.9

Note 1 : Contact positions without HRS No. are currently under planning.

Please contact HRS for detailed information about product variation.

◆ Material composition of FPC/FFC/Shield FFC (Recommended specifications)

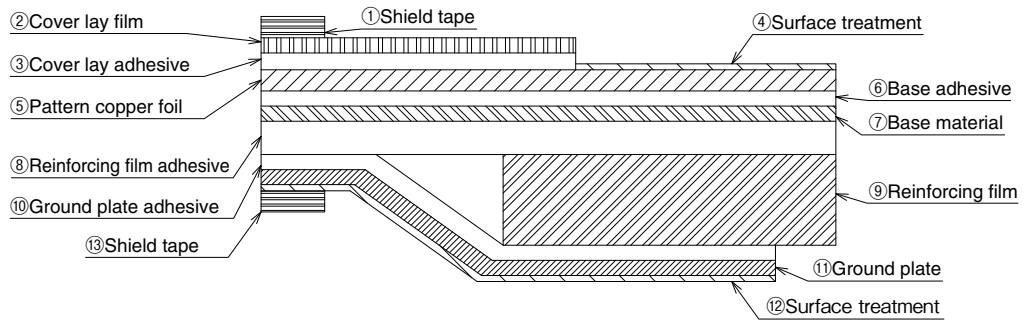

	Material name	FPC		FFC		
		Materials	Thickness (μm)	Materials	Shield FFC Thickness (μm)	FFC Thickness (μm)
①	Shield tape	—	—	—	—	—
②	Cover lay film	Polyimide 1mil	25	Polyester	25	25
③	Cover lay adhesive	Thermosetting adhesive	28	Adhesive	25	25
④	Surface treatment	Nickel foundation 1 to 6μm + Gold plated 0.2μm	(3.7)	Nickel foundation 0.5 to 5μm + Gold plated 0.05 to 1μm	(3.275)	(3.275)
⑤	Pattern copper foil	Rolled copper 1oz	35	Annealed copper foil	35	35
⑥	Base adhesive	Thermosetting adhesive	8	Adhesive	25	25
⑦	Base material	Polyimide 1mil	25	Polyester	25	50
⑧	Reinforcing film adhesive	Thermosetting adhesive	55	Adhesive	30	30
⑨	Reinforcing film	Polyimide 8mil	200	Polyester	150	188
⑩	Ground plate adhesive	—	—	Adhesive	30	—
⑪	Ground plate	—	—	Copper foil Tin plated 1 to 5μm	37	—
⑫	Surface treatment	—	—	—	—	—
⑬	Shield tape	—	—	—	—	—

Caution

1. This specification is recommendation for the construction of the FH67 series FPC/FFC/Shield FFC (t=0.33±0.03mm)
2. For details about the construction, please contact FPC/FFC/Shield FFC manufacturers.

◆ Packaging Specifications

● Embossed Carrier Tape Dimensions

Tape width : 24mm or less

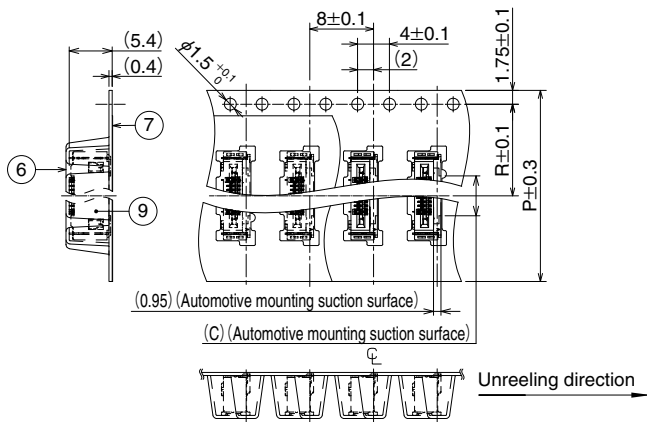

Tape width : 32mm or less

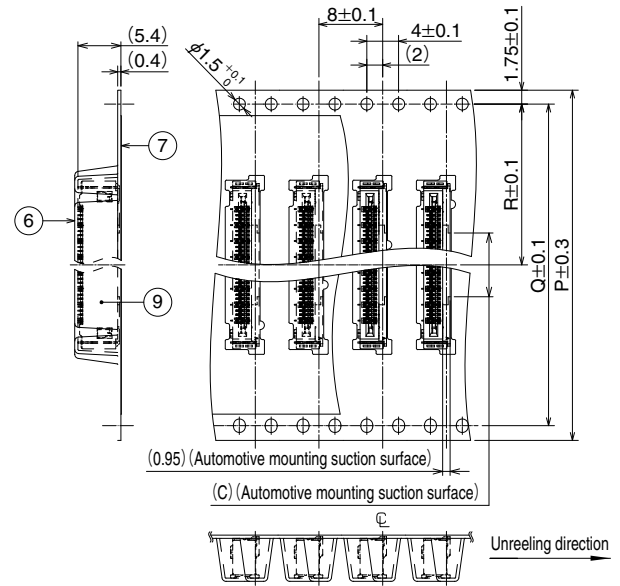

● Reel Dimensions

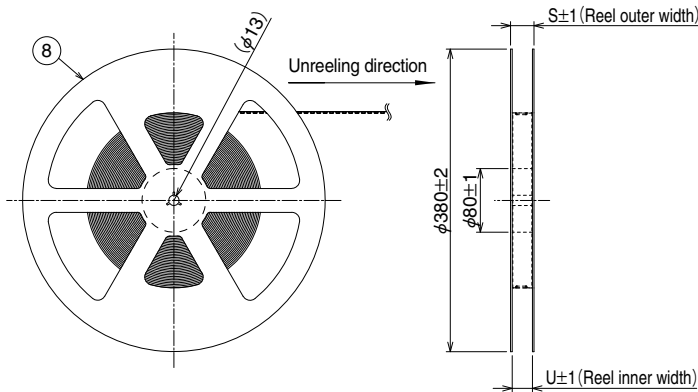

● Leader, Trailer Dimensions

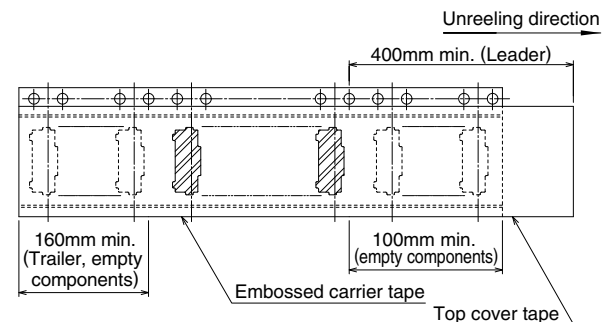

Note 9 : 1000 pieces packaged in one reel. (For standard products)

Note 10 : The package complies with JIS C 0806 and IEC 60286-3 (Packaging of automotive mounting parts) standards.

Unit : mm

Part No.	HRS No.	No. of Contacts	C	P	Q	R	S	U
FH67-10S-0.5SV	Under planning (Note 1)	10	5	24	—	11.5	29.4	25.4
FH67-20S-0.5SV	Under planning (Note 1)	20	7.5	32	28.4	14.2	37.4	33.4
FH67-30S-0.5SV	580-4901-0 **	30	8	44	40.4	20.2	49.4	45.4
FH67-40S-0.5SV	580-4903-0 **	40	8	44	40.4	20.2	49.4	45.4

Note 1 : Contact positions without HRS No. are currently under planning.

Please contact HRS for detailed information about product variation.

◆ Temperature Profile

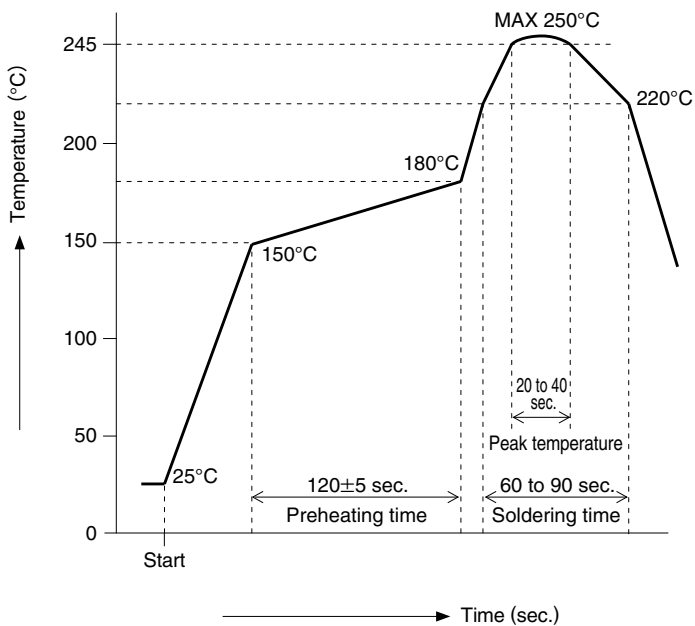

Applicable Conditions

- Reflow method : IR/Hot air
- Reflow environment : Room air
- Solder : Paste type Sn/3.0Ag/0.5Cu
(M705-GRN360-K2-V made by Senju Metal Industry Co.)
- Test PCB : PCB material and size
Glass epoxy 45×25×1mm
Land size, per recommended on page 4.
- Metal mask : Thickness and opening size
Per recommendation on page 4.

This temperature profile is based on the above conditions. It may vastly depending on solder paste type, manufacturer, PCB size and mounting materials. Please use only after checking the mounting conditions.

[Operation Method]

Care needs to be taken when handling this connector. In order to prevent the damage and contact failure etc. (incorrect mating, disconnection of FPC pattern) of connectors and FPC, please use after confirming the following contents.

This connector supports FPC/FFC/Shield FFC, however, for convenience, the description is made only for FPC.

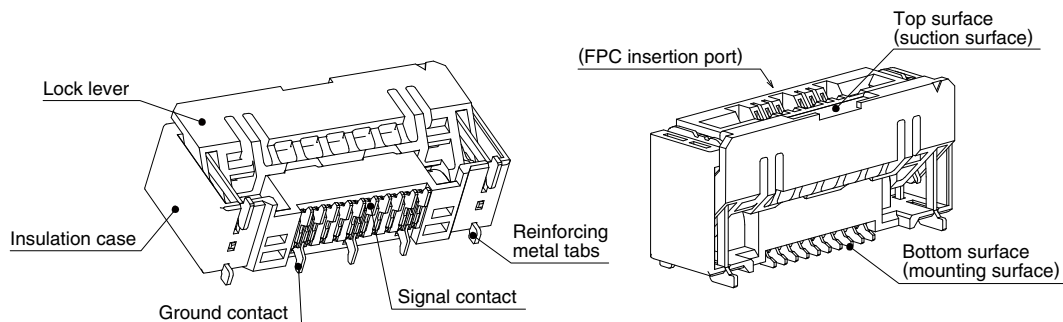

1. Delivered state

This product is delivered with the lock lever closed. The lock lever does not need to be operated before inserting FPC.

[Caution]

- Do not open the lock lever when FPC is not inserted.
Additionally, the lock lever does not need to be opened except to remove the FPC. (Example 1)
- Do not operate the connector until it is mounted on the board. (Example 1)

(Example 1)

NG

— Delivered state —

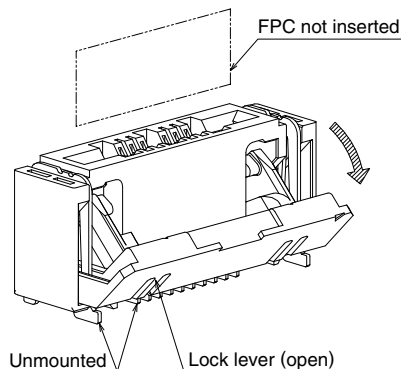
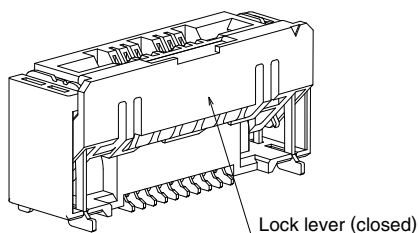

[Operation Method]

2. How to insert FPC

Insert FPC to the end correctly (Example 2) vertical to the board surface.

[Caution]

- Please confirm that the lock lever is closed when you insert FPC.
Do not insert FPC while the lock lever is open. (Example 3)
- Product is designed so that the FPC cannot be inserted when the lock lever is opened. However forcing insertion is a cause of damage.
- Do not FPC while at the same time pressing the lock lever. (Example 4)
- Insert FPC pattern side facing opposite of the lock lever operation part. (Example 5)
- Insert FPC straight after positioning its tip end vertically in reference to the guides on both ends of the connector mating port. (Example 6)
- Do not insert diagonally. (Example 7)
- When inserting, do not move the FPC in a vertical, lateral or diagonal direction. (Example 8)
(Recommended Insertion Angle $\pm 2.5^\circ$)
- Refrain from opening the lock level with a finger when inserting the FPC. (Example 9)

(Example 2)

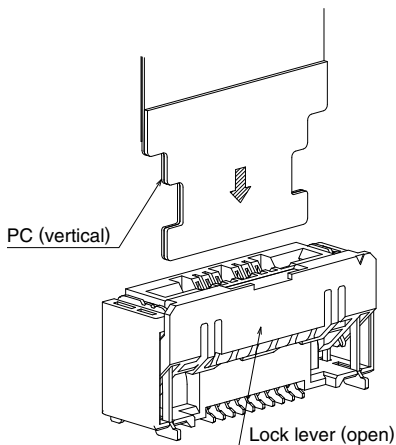

(Example 3)

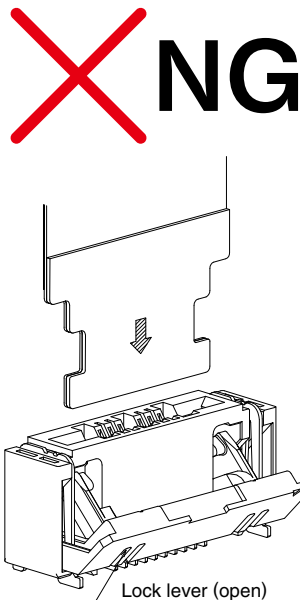

(Example 4)

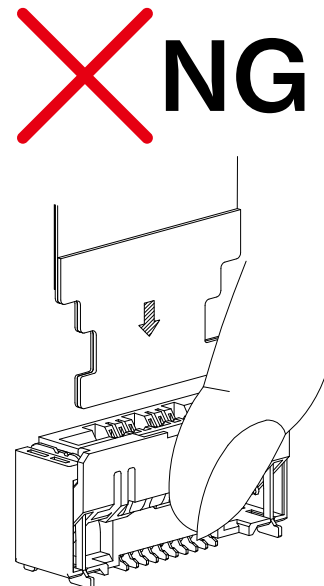

(Example 5)

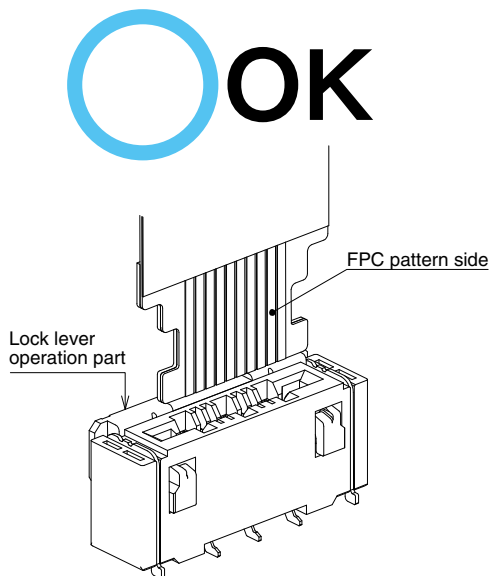

(Example 6)

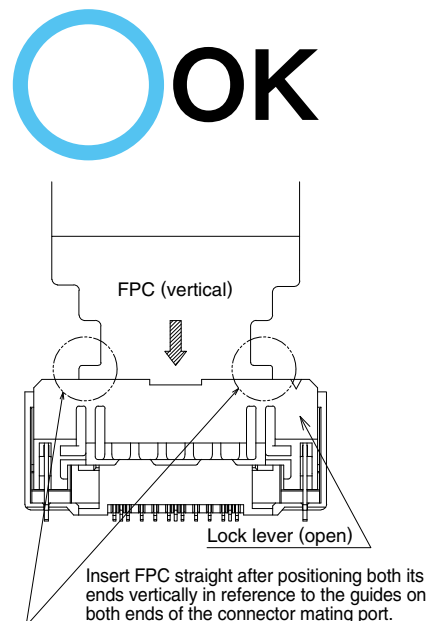

[Operation Method]

(Example 7)

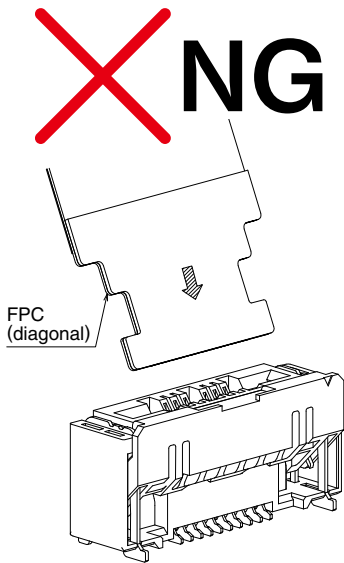

(Example 8)

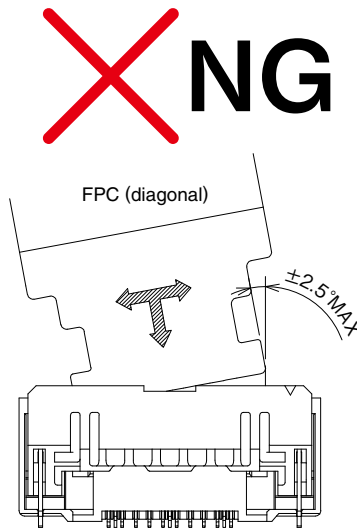

(Example 9)

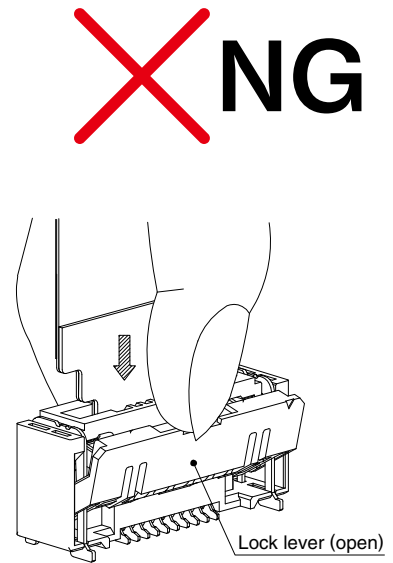

3. Confirming the mated state of FPC

When FPC is completely inserted, visually inspect the inserted status of FPC. (Example 10)
 (This connector uses the lock protrusion of the lock lever for positioning FPC.)

[Caution]

- FPC is not inserted deep enough or in a diagonal direction. (Example 11)(Example 12)
- Because of the one action lock, the lever does not need to be operated after inserting FPC.

(Example 10)

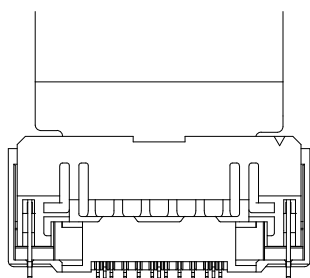

FPC inserted to the back of the mating port.

(Example 11)



FPC is not inserted deep enough, leaving a large gap between FPC and the housing.

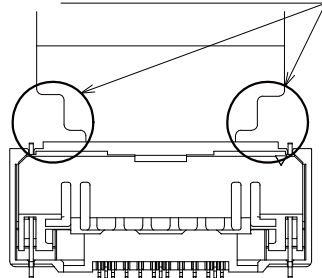

FPC is not inserted deep enough down to the back of the mating port.

(Example 12)



FPC is inserted diagonally, leaving a large gap between FPC and the housing.

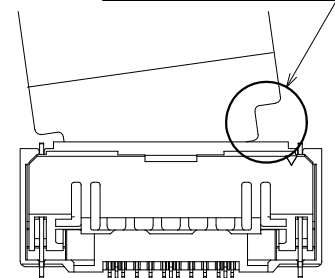

FPC positioned diagonally is not inserted to the back of the mating port.

Can see viewing section when FPC is inserted to the back of the mating port.

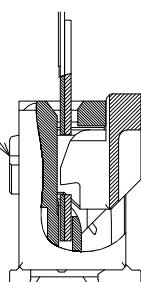

— Cross section of the lock section —

Cannot see viewing section when FPC is not fully inserted.

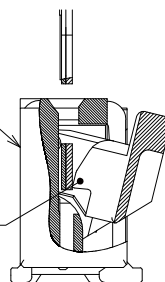

The protrusion of the lock lever runs over the FPC tab.

— Cross section of the lock section —

Cannot see viewing section when FPC is not fully inserted.

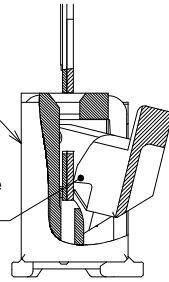

The protrusion of the lock lever runs over the tab.

— Cross section of the lock section —

[Operation Method]

4. How to unlock the lock lever

Push down the lock lever slowly, and release the lock. (Example 13)

[Caution]

- When releasing the lock operate the lock lever around the center. (Example 14)
- When releasing the lock do not operate only one side of the lock lever. (Example 15)
- As the lock lever cannot be opened to over 45°, do not open it over this angle. (Example 16)
- Do not pick and raise the lock lever or pull it. (Example 17)
- Be sure to operate the lock lever by hand, and do not operate it with sharp-edged tools such as tweezers etc. (Example 18)
- Don't apply an excessive force to the housing during operation. (Example 19)

(Example 13)

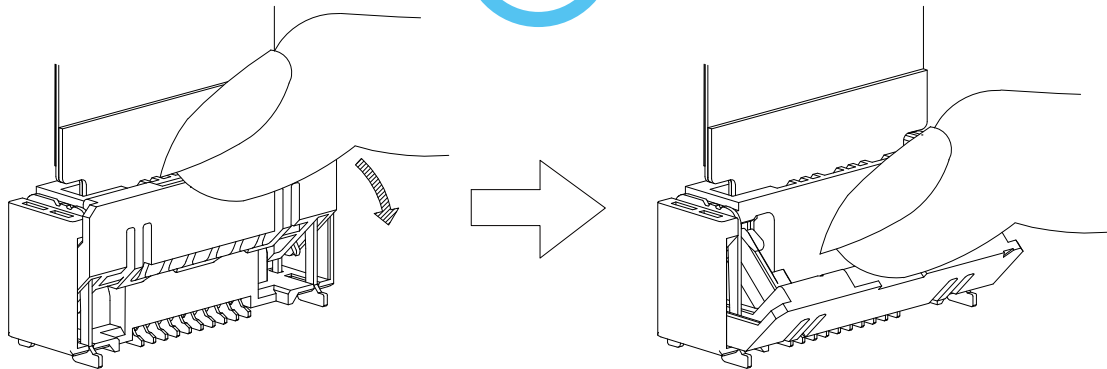

(Example 14)



Operate the lock lever around the center.

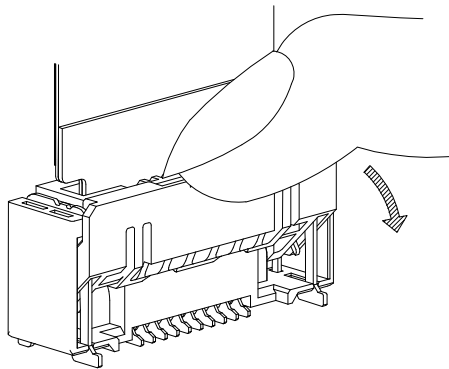

(Example 15)



Operate the lock lever on one side.

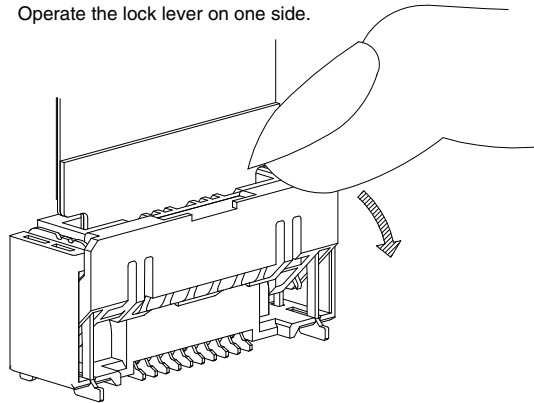

[Operation Method]

(Example 16)

NG

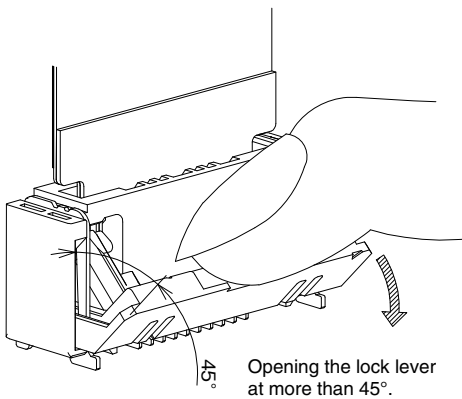

(Example 17)

NG

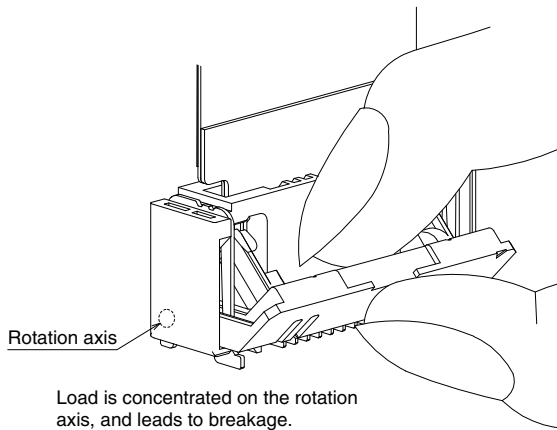

(Example 18)

NG

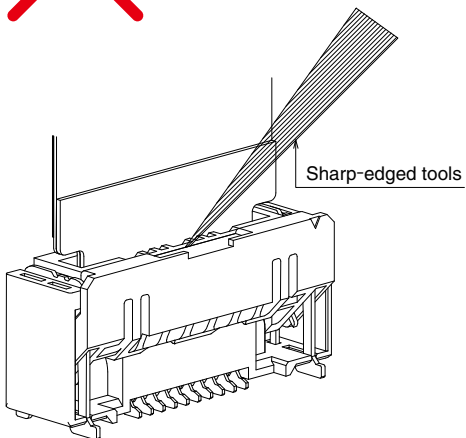

(Example 19)

NG

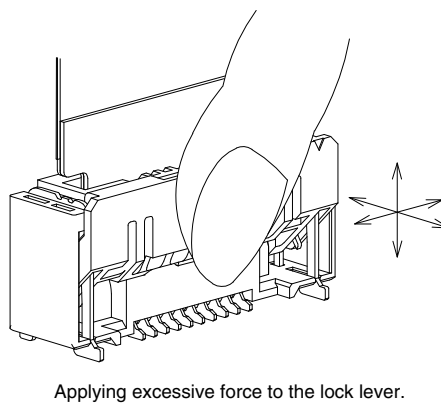

[Operation Method]

5. How to remove the FPC

After releasing the lock lever, remove the FPC vertically from the board side. (Example 20)

When removing the FPC do not press the lock lever. (Example 21)

The released lock lever is designed to close automatically at the time of FPC release. However if it does not please close the lock with your finger. (Example 22)

[Caution]

- Do not pull out FPC while the lever is locked. (Example 23)
- There is a possibility of decrease in the FPC's retention force after forcefully removing the FPC.
- This connector is equipped with the FPC retention mechanism by means of the lock lever.
- When pulling out FPC, do not apply load in any direction other than vertical to the board side. (Example 24)

(Example 20)

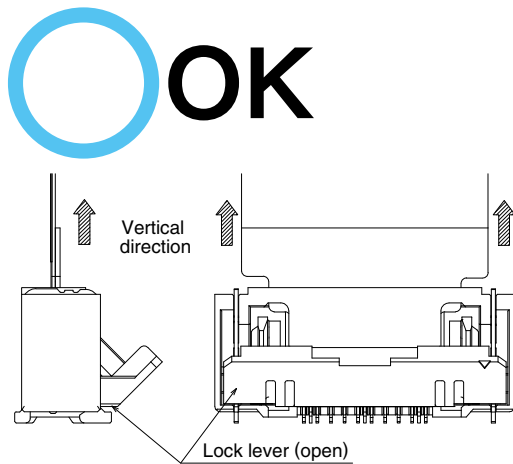

(Example 21)

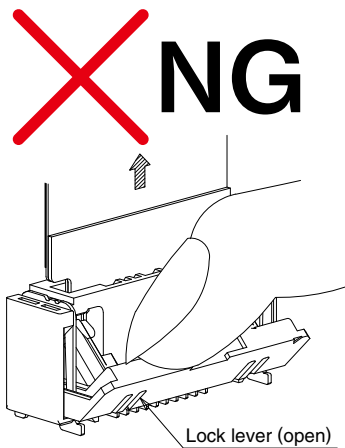

(Example 22)

— Condition after FPC is pulled out —

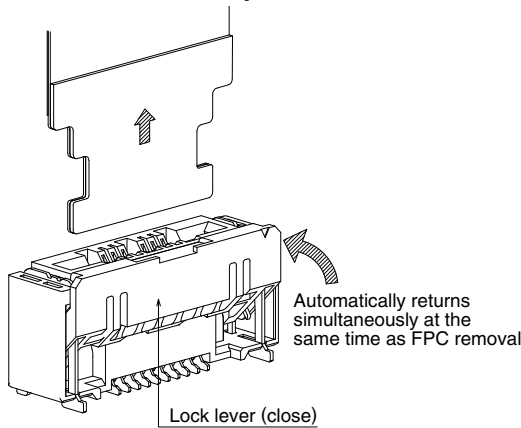

(Example 23)

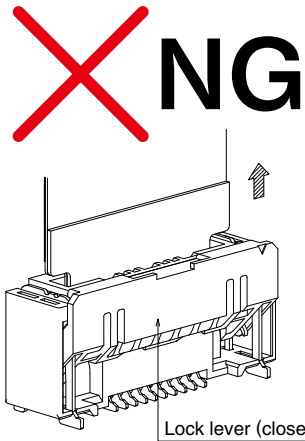

(Example 24)

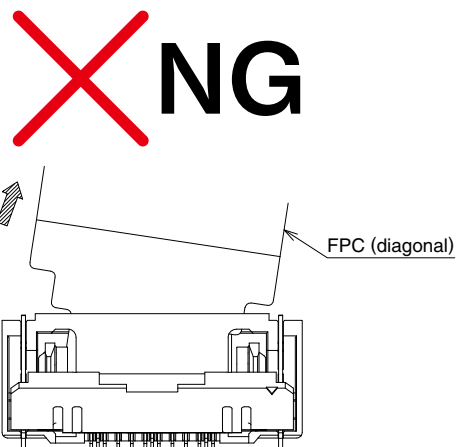
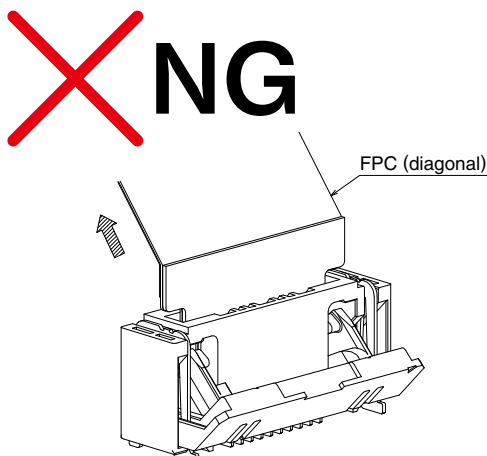

[Operation method]

[Cautions for PCB layout]

Depending on the routing of the mating FPC, a load may be applied to the connector, which may cause failure. In order to prevent this, please consider the following concerning the mechanism design.

[Caution]

- When routing the FPC, please be careful that FPC is not pulled and routing is carried out with extra space. Please check that the reinforcing film is placed vertical to the board surface. (Example 25)
- Please insure there is no load applied to the connector in the pulling, inserting or lateral direction. A bent FPC, it could cause contact failure or damage/disconnection of FPC. Therefore, please take some measure to fix FPC etc. (Example 26)(Example 27)
- Don't place enclosures or mounting parts that will interfere with FPC. (Example 28)
- As for the flexibility of FPC, please make adjustments with the FPC manufacturer.
- Please ensure the FPC has adequate insertion space when designing the layout so that it is not inserted diagonally. Additionally, ensure the insertion space is not too short for FPC. Please adopt adequate parts layout and length for FPC.
- When you design the board/layout, please secure required space for operation.

(Example 25)



Routing that does not put load on reinforcing film

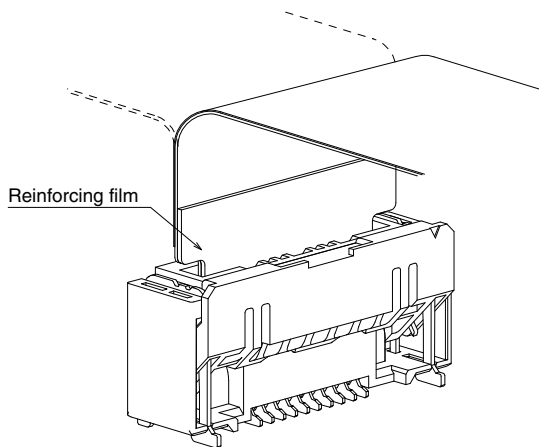

(Example 26)



Routing that passed load on reinforcing film

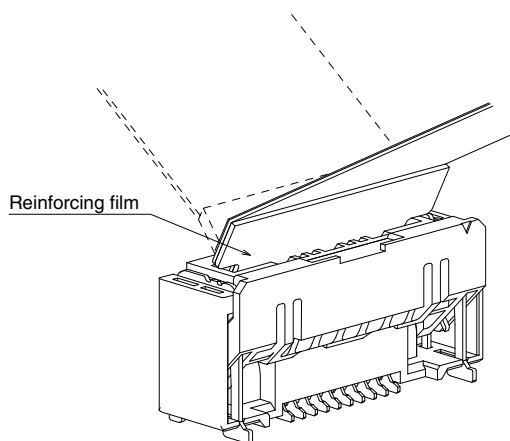

(Example 27)



The state where a load is applied to FPC

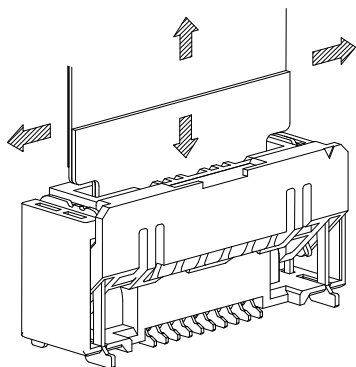

(Example 28)



Enclosure/ mouting parts interfering with FPC

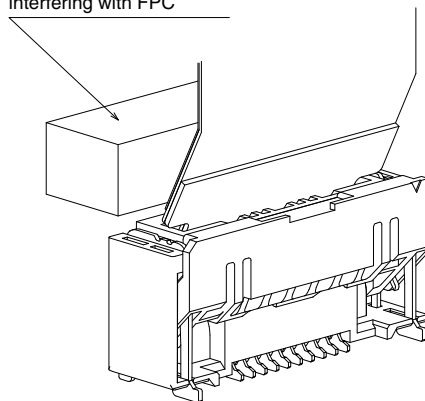

[Notes for mounting on the board/after mounting on the board]

[Notes for board mounting]

Please be careful of the following at the time of board mounting.

[Caution]

- Please confirm recommendations for mount board land shape, metal mask opening shape, and FPC shape.
- If the land is narrower or if the metal mask opening is wider than recommended, solder (flux) wicking is more likely to occur.
If there is difference from the recommendation, please use after checking the mounting state.
- The level difference between the bottom surfaces of contact lead and the mold is designed to be small.
When there is silk print etc. on the bottom surface of the connector, it could push up the bottom surface of the connector and cause solder detachment or defective fillet formation.
When there is silk print etc. on the bottom surface of the connector, please use after checking the mounted state.
- Use the reflow conditions within the specifications of our company.
The mounted status may vary due to external conditions such as the paste solder type, manufacturer, and board size. Please use it after checking the mounted state.
- Please control the board warpage as much as possible. While the coplanarity of this connector is 0.1mm or less, defective soldering could occur if the board warpage is considerable.
- When mounted on FPC, be sure to provide a reinforcing plate to ease handling. We recommend a reinforcing plate of 0.3mm or thicker made of glass epoxy material.
- When pulling out the emboss from the reel, or when the connector is picked from the emboss do not apply any excessive external force (of 1N or more) to the connector before mounting.

[Cautions when handling the board after mounting]

Please be careful of the following when handling the board after mounting operation.

[Caution]

- Do not apply any load to the board in the assembly process, such as dividing a multi-piece board or securing the board to the frame.
Applying a load to the connector may damage it.
- Use the board with the deflection being 1mm or less when the board width is 100mm. (Example 29)
If the board has some deflection, it could apply a load to the connector and damage it.

(Example 29)

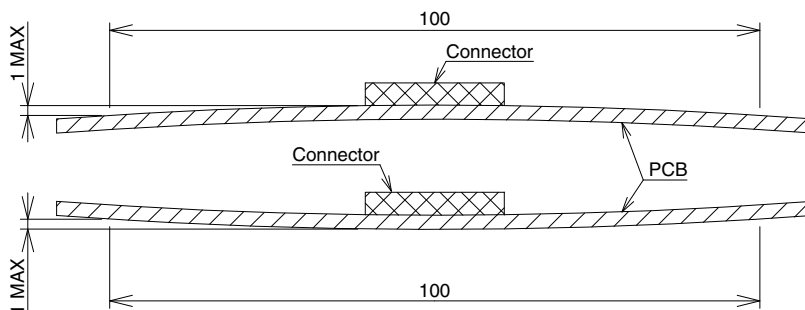

[Cautions for hand-soldering]

Please be careful of the following when hand-soldering for repair work etc.

[Caution]

- Do not hand-solder while FPC is inserted.
- Please be careful not to apply excessive heat or allow the solder iron to touch any place other than the connector contact lead. Such action could cause the connector to be deformed or melted.
- Do not supply an excessive amount of solder (flux).
If too much solder (flux) is supplied to the contact, the solder or flux could adhere on the contact point and cause contact failure.
Additionally, if you supply too much solder to the reinforcing metal tabs the rotational action of the lock lever could be defective and the connector could be damaged.



HIROSE ELECTRIC CO.,LTD.

2-6-3,Nakagawa Chuoh,Tsuzuki-Ku,Yokohama-Shi 224-8540,JAPAN
 TEL: +81-45-620-3526 Fax: +81-45-591-3726
<http://www.hirose.com>
<http://www.hirose-connectors.com>