



TMC246/B – DATA SHEET

High current microstep stepper motor driver with stallGuard™, protection / diagnostics and SPI Interface

TRINAMIC® Motion Control GmbH & Co KG
Hamburg, Germany

WWW.TRINAMIC.COM



Features

The TMC246 / TMC246A / TMC246B (1) is a dual full bridge driver IC for bipolar stepper motor control applications. The integrated unique sensorless stall detection (pat. pend.) stallGuard™ makes it a good choice for applications, where a reference point is needed, but where a switch is not desired. Its ability to predict an overload makes the TMC246 an optimum choice for drives, where a high reliability is desired. The TMC246 is realized in a HVCMOS technology combined with Low-RDS-ON high efficiency MOSFETs (pat. pend.). It allows driving a coil current of up to 1500mA even at high environment temperatures. Its low current consumption and high efficiency together with the miniature package make it a perfect solution for embedded motion control and for battery powered devices. Internal DACs allow microstepping as well as smart current control. The device can be controlled by a serial interface (SPI™) or by analog / digital input signals. Short circuit, temperature, undervoltage and overvoltage protection are integrated.

- Sensorless stall detection stallGuard™ and load measurement integrated
- Control via SPI with easy-to-use 12 bit protocol or external analog / digital signals
- Short circuit, overvoltage and over temperature protection integrated
- Status flags for overcurrent, open load, over temperature, temperature pre-warning, undervoltage
- Integrated 4 bit DACs allow up to 16 times microstepping via SPI (can be expanded to 64 microsteps)
- Any resolution via analog control
- Mixed decay feature for smooth motor operation
- Slope control user programmable to reduce electromagnetic emissions
- Chopper frequency programmable via a single capacitor or external clock
- Current control allows cool motor and driver operation
- 7V to 34V motor supply voltage (A-type)
- Up to 1500mA output current and more than 800mA at 105°C
- 3.3V or 5V operation for digital part
- Low power dissipation via low RDS-ON power stage
- Standby and shutdown mode available

- (1) The term TMC246 in this datasheet always refers to the TMC246B, TMC246A and the TMC246. The major differences in the older TMC246 are explicitly marked with “non-A-type”. The TMC246A brings a number of enhancements and is fully backward compatible to the TMC246. The latest revision TMC246B is 100% compatible to the TMC246A.

FEATURES	1
PINNING.....	5
PACKAGE CODES.....	5
PQFP44 DIMENSIONS.....	6
APPLICATION CIRCUIT / BLOCK DIAGRAM	7
PIN FUNCTIONS.....	7
LAYOUT CONSIDERATIONS	8
CONTROL VIA THE SPI INTERFACE	9
SERIAL DATA WORD TRANSMITTED TO TMC246	9
SERIAL DATA WORD TRANSMITTED FROM TMC246	9
TYPICAL WINDING CURRENT VALUES.....	10
BASE CURRENT CONTROL VIA INA AND INB IN SPI MODE	10
CONTROLLING THE POWER DOWN MODE VIA THE SPI INTERFACE	10
OPEN LOAD DETECTION	11
STANDBY AND SHUTDOWN MODE	11
POWER SAVING	11
STALL DETECTION	12
USING THE SENSORLESS LOAD MEASUREMENT	12
IMPLEMENTING SENSORLESS STALL DETECTION	12
PROTECTION FUNCTIONS	13
OVERCURRENT PROTECTION AND DIAGNOSIS.....	13
OVERTEMPERATURE PROTECTION AND DIAGNOSIS	13
OVERVOLTAGE PROTECTION AND ENN PIN BEHAVIOR	13
CHOPPER PRINCIPLE.....	14
CHOPPER CYCLE / USING THE MIXED DECAY FEATURE	14
ADAPTING THE SINE WAVE FOR SMOOTH MOTOR OPERATION.....	15
BLANK TIME	15
BLANK TIME SETTINGS	15
CLASSICAL NON-SPI CONTROL MODE (STAND ALONE MODE).....	16
PIN FUNCTIONS IN STAND ALONE MODE	16
INPUT SIGNALS FOR MICROSTEP CONTROL IN STAND ALONE MODE.....	16
CALCULATION OF THE EXTERNAL COMPONENTS	17
SENSE RESISTOR.....	17
EXAMPLES FOR SENSE RESISTOR SETTINGS.....	17
HIGH SIDE OVERCURRENT DETECTION RESISTOR R_{SH}	17
MAKING THE CIRCUIT SHORT CIRCUIT PROOF	18
OSCILLATOR CAPACITOR.....	19
TABLE OF OSCILLATOR FREQUENCIES.....	19
PULLUP RESISTORS ON UNUSED INPUTS	19
POWER SUPPLY SEQUENCING CONSIDERATIONS	19
SLOPE CONTROL RESISTOR	20
EXAMPLE FOR SLOPE SETTINGS	20
ABSOLUTE MAXIMUM RATINGS	21
ELECTRICAL CHARACTERISTICS	21
OPERATIONAL RANGE	21
DC CHARACTERISTICS	22
AC CHARACTERISTICS.....	23
THERMAL PROTECTION.....	24

THERMAL CHARACTERISTICS	24
TYPICAL POWER DISSIPATION AT HIGH LOAD / HIGH TEMPERATURE	24
SPI INTERFACE TIMING.....	25
PROPAGATION TIMES	25
USING THE SPI INTERFACE	25
SPI FILTER	25
ESD PROTECTION.....	26
APPLICATION NOTE: EXTENDING THE MICROSTEP RESOLUTION	27
DOCUMENTATION REVISION	28

Life support policy

TRINAMIC Motion Control GmbH & Co KG does not authorize or warrant any of its products for use in life support systems, without the specific written consent of TRINAMIC Motion Control GmbH & Co KG.

Life support systems are equipment intended to support or sustain life, and whose failure to perform, when properly used in accordance with instructions provided, can be reasonably expected to result in personal injury or death.

© TRINAMIC Motion Control GmbH & Co KG 2005

Information given in this data sheet is believed to be accurate and reliable. However no responsibility is assumed for the consequences of its use nor for any infringement of patents or other rights of third parties, which may result from its use.

Specifications subject to change without notice.

Pinning

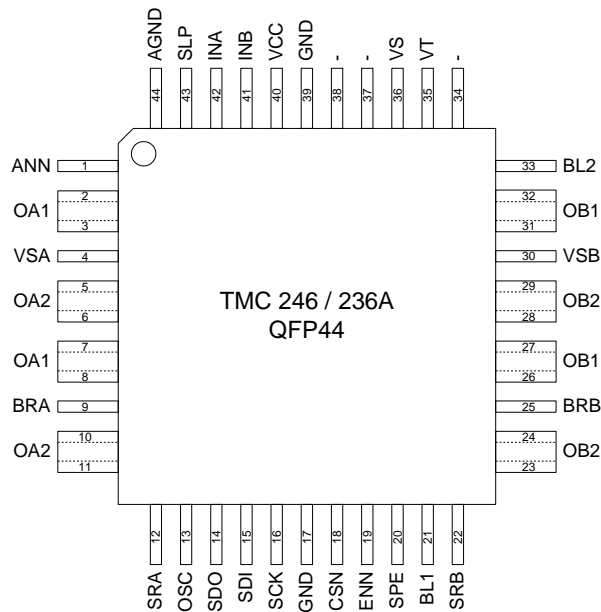

Package codes

Type	Package	Temperature range	Lead free (ROHS)	Code/markings
TMC246B	PQFP44	automotive (1)	Yes	TMC246B-PA
TMC246A	PQFP44	automotive (1)	Yes	TMC246A-PA
TMC246	PQFP44	automotive (1)	From date code 30/04	TMC246-PA

(1) ICs are not tested according to automotive standards, but are usable within the complete automotive temperature range.

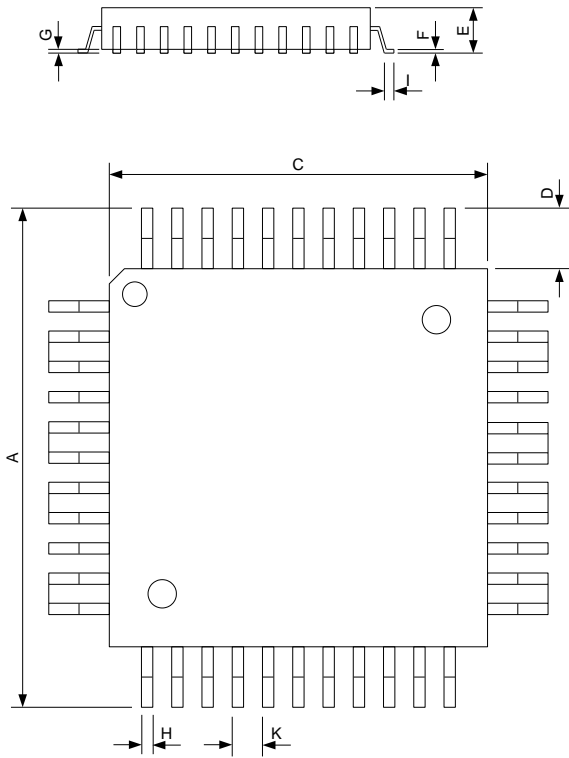
PQFP44 Dimensions

REF	MIN.	MAX.
A		12
C		10
D		1
E	-	1.6
F	0.09	0.2
G	0.05	0.15
H	0.30	0.45
I	0.45	0.75
K	0.8	
L	0	0.08

All dimensions are in mm.
L: Co-planarity of pins

Application Circuit / Block Diagram

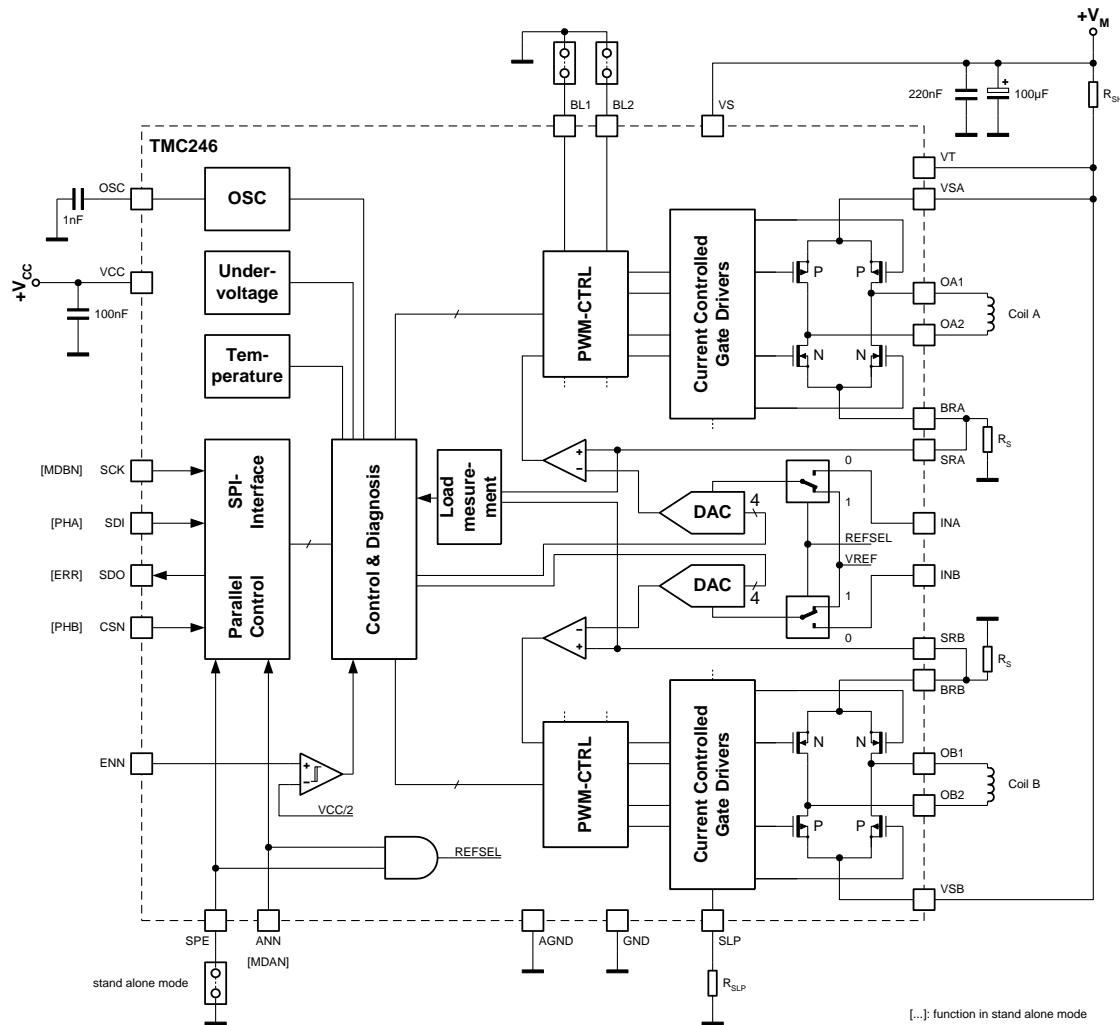

Pin Functions

Pin	Function	Pin	Function
VS	Motor supply voltage	VT	Short to GND detection comparator – connect to VS if not used
VCC	3.0-5.5V supply voltage for analog and logic circuits	GND	Digital / Power ground
AGND	Analog ground (Reference for SRA, SRB, OSC, SLP, INA, INB, SLP)	OSC	Oscillator capacitor or external clock input for chopper
INA	Analog current control phase A	INB	Analog current control input phase B
SCK	Clock input of serial interface	SDO	Data output of serial interface (tri-state)
SDI	Data input of serial interface	CSN	Chip select input of serial interface
ENN	Device enable (low active), and overvoltage shutdown input	SPE	Enable SPI mode (high active). Tie to GND for non-SPI applications
ANN	Enable analog current control via INA and INB (low active)	SLP	Slope control resistor.
BL1, BL2	Digital blank time select	SRA, SRB	Bridge A/B current sense resistor input
OA1, OA2	Output of full-bridge A	OB1, OB2	Output of full-bridge B
VSA, VSB	Supply voltage for bridge A/B	BRA, BRB	Bridge A/B sense resistor

Layout Considerations

For optimal operation of the circuit a careful board layout is important, because of the combination of high current chopper operation coupled with high accuracy threshold comparators. Please pay special attention to a massive grounding. Depending on the required motor current, either a single massive ground plane or a ground plane plus star connection of the power traces may be used. The schematic shows how the high current paths can be routed separately, so that the chopper current does not flow through the system's GND-plane. Tie the TMC246's AGND and GND to the GND plane. Additionally, use enough filtering capacitors located near to the board's power supply input and small ceramic capacitors near to the power supply connections of the TMC246. Use low inductance sense resistors, or add a ceramic capacitor in parallel to each resistor to avoid high voltage spikes. In some applications it may become necessary to introduce additional RC-filtering into the VT and SRA / SRB line, as shown in the schematic, to prevent spikes from triggering the short circuit protection or the chopper comparator.

Be sure to connect all pins of the PQFP package for each of the double/quad output pins externally. Each two of these output pins should be treated as if they were fused to a single wide pin (as shown in the drawing). Each two pins are used as cooling fin for one of the eight integrated output power transistors. Use massive motor current traces on all these pins and multiple vias, if the output trace is changed to a different layer near the package.

A symmetrical layout on all of the OA and OB pins is required, to ensure proper heat dissipation on all output transistors. Otherwise proper function of the thermal protection can not be guaranteed!

A multi-layer PCB shows superior thermal performance, because it allows usage of a massive GND plane, which will act as a heat spreader. The heat will be coupled vertically from the output traces to the GND plane, since vertical heat distribution in PCBs is quite effective. Heat dissipation can be improved by attaching a heat sink to the package directly.

Please be aware, that long or thin traces to the sense resistors may add substantial resistance and thus reduce output current. The same is valid for the high side shunt resistor. Use short and straight traces to avoid parasitic inductivities, because these can generate large voltage spikes and EMV problems.

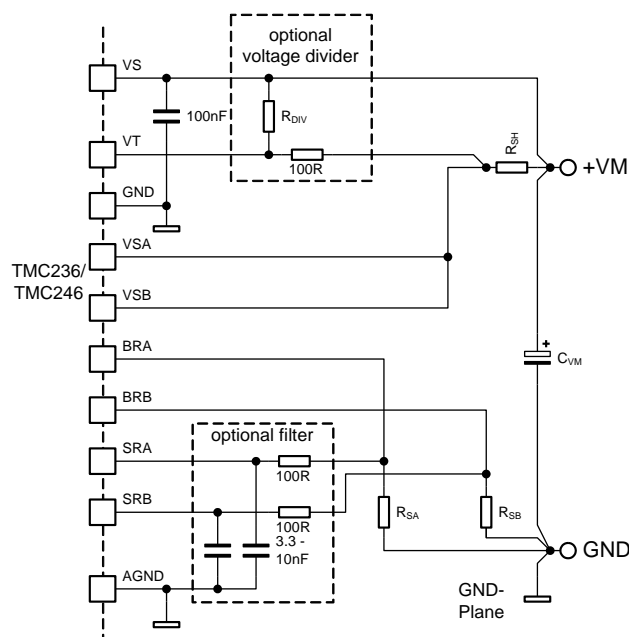

Control via the SPI Interface

The SPI data word sets the current and polarity for both coils. By applying consecutive values, describing a sine and a cosine wave, the motor can be driven in microsteps. Every microstep is initiated by its own telegram. Please refer to the description of the analog mode for details on the waveforms required. The SPI interface timing is described in the timing section. We recommend the TMC428 to automatically generate the required telegrams and motor ramps for up to three motors.

Serial data word transmitted to TMC246

(MSB transmitted first)

Bit	Name	Function	Remark
11	MDA	mixed decay enable phase A	"1" = mixed decay
10	CA3	current bridge A.3	MSB
9	CA2	current bridge A.2	
8	CA1	current bridge A.1	
7	CA0	current bridge A.0	LSB
6	PHA	polarity bridge A	"0" = current flow from OA1 to OA2
5	MDB	mixed decay enable phase B	"1" = mixed decay
4	CB3	current bridge B.3	MSB
3	CB2	current bridge B.2	
2	CB1	current bridge B.1	
1	CB0	current bridge B.0	LSB
0	PHB	polarity bridge B	"0" = current flow from OB1 to OB2

Serial data word transmitted from TMC246

(MSB transmitted first)

Bit	Name	Function	Remark
11	LD2	load indicator bit 2	MSB
10	LD1	load indicator bit 1	
9	LD0	load indicator bit 0	LSB
8	1	always "1"	
7	OT	over temperature	"1" = chip off due to over temperature
6	OTPW	temperature pre-warning	"1" = pre-warning temperature exceeded
5	UV	driver undervoltage	"1" = undervoltage on VS
4	OCHS	overcurrent high side	3 PWM cycles with overcurrent within 63 PWM cycles
3	OLB	open load bridge B	no PWM switch off for 14 oscillator cycles
2	OLA	open load bridge A	no PWM switch off for 14 oscillator cycles
1	OCB	overcurrent bridge B low side	3 PWM cycles with overcurrent within 63 PWM cycles
0	OCA	overcurrent bridge A low side	3 PWM cycles with overcurrent within 63 PWM cycles

Typical winding current values

Current setting CA3..0 / CB3..0	Percentage of current	Typical trip voltage of the current sense comparator (internal reference or analog input voltage of 2V is used)
0000	0%	0 V (bridge continuously in slow decay condition)
0001	6.7%	23 mV
0010	13.3%	45 mV
...	...	
1110	93.3%	317 mV
1111	100%	340 mV

The current values correspond to a standard 4 Bit DAC, where 100%=15/16. The contents of all registers is cleared to “0” on power-on reset or disable via the ENN pin, bringing the chip to a low power standby mode. All SPI inputs have Schmitt-Trigger function.

Base current control via INA and INB in SPI mode

In SPI mode, the IC can use an external reference voltage for each DAC. This allows the adaptation to different motors. This mode is enabled by tying pin ANN to GND. A 2.0V input voltage gives full scale current of 100%. In this case, the typical trip voltage of the current sense comparator is determined by the input voltage and the DAC current setting (see table above) as follows:

$$V_{TRIP,A} = 0.17 V_{INA} \times \text{“percentage SPI current setting A”}$$

$$V_{TRIP,B} = 0.17 V_{INB} \times \text{“percentage SPI current setting B”}$$

A maximum of 3.0V V_{IN} is possible. Multiply the percentage of base current setting and the DAC table to get the overall coil current. It is advised to operate at a high base current setting, to reduce the effects of noise voltages. This feature allows a high resolution setting of the required motor current using an external DAC or PWM-DAC (see schematic for examples).

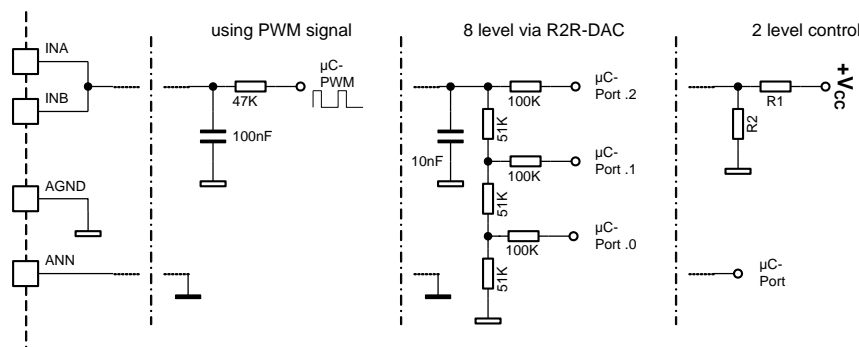

Controlling the power down mode via the SPI interface

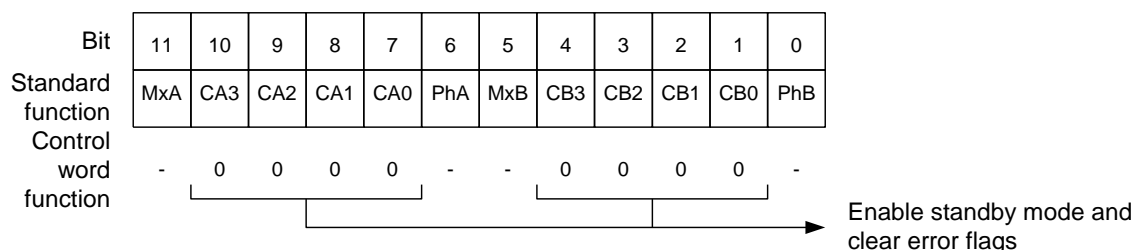

Programming current value “0000” for both coils at a time clears the overcurrent flags and switches the TMC246 into a low current standby mode with coils switched off.

Open load detection

Open load is signaled whenever there are more than 14 oscillator cycles without PWM switch off. Note that open load detection is not possible while coil current is set to "0000", because the chopper is off in this condition. The open load flag will then always be read as inactive ("0"). During overcurrent and undervoltage or over temperature conditions, the open load flags also become active!

Due to their principle, the open load flags not only signal an open load condition, but also a torque loss of the motor, especially at high motor velocities. To detect only an interruption of the connection to the motor, it is advised to evaluate the flags during stand still or during low velocities only (e.g. for the first or last steps of a movement).

Standby and shutdown mode

The circuit can be put into a low power standby mode by the user, or, automatically goes to standby on Vcc undervoltage conditions. Before entering standby mode, the TMC246 switches off all power driver outputs. In standby mode the oscillator becomes disabled and the oscillator pin is held at a low state. The standby mode is available via the interface in SPI-mode and via the ENN pin in non-SPI mode.

The shutdown mode even reduces supply current further. It can only be entered in SPI-mode by pulling the ENN pin high. In shutdown additionally all internal reference voltages become switched off and the SPI circuit is held in reset.

Power saving

The possibility to control the output current can dramatically save energy, reduce heat generation and increase precision by reducing thermal stress on the motor and attached mechanical components. Just reduce motor current during stand still: Even a slight reduction of the coil currents to 70% of the current of the last step of the movement, halves power consumption! In typical applications a 50% current reduction during stand still is reasonable.

Stall Detection

Using the sensorless load measurement

The TMC246 provides a patented sensorless load measurement, which allows a digital read out of the mechanical load on the motor via the serial interface. To get a readout value, just drive the motor using sine commutation and mixed decay switched off. The load measurement then is available as a three bit load indicator during normal motion of the motor. A higher mechanical load on the motor results in a lower readout value. The value is updated once per fullstep.

The load detection is based on the motor's back EMF, thus the level depends on several factors:

- Motor velocity: A higher velocity leads to a higher readout value
- Motor resonance: Motor resonances cause a high dynamic load on the motor, and thus measurement may give unsatisfactory results.
- Motor acceleration: Acceleration phases also produce dynamic load on the motor.
- Mixed decay setting: For load measurement mixed decay has to be off for some time before the zero crossing of the coil current. If mixed decay is used, and the mixed decay period is extended towards the zero crossing, the load indicator value decreases.

Implementing sensorless stall detection

The sensorless stall detection typically is used, to detect the reference point without the usage of a switch or photo interrupter. Therefore the actuator is driven to a mechanical stop, e.g. one end point in a spindle type actuator. As soon as the stop is hit, the motor stalls. Without stall detection, this would give an audible humming noise and vibrations, which could damage mechanics.

To get a reliable stall detection, follow these steps:

1. Choose a motor velocity for reference movement. Use a medium velocity which is far enough away from mechanical resonance frequencies. In some applications even motor start / stop frequency may be used. With this the motor can stop within one fullstep if a stall is detected.
2. Use a sine stepping pattern and switch off mixed decay (at least 1 to 3 microsteps before zero crossing of the wave). Monitor the load indicator during movement. It should show a stable readout value in the range 3 to 7 (L_{MOVE}). If the readout is high (>5), the mixed decay portion may be increased, if desired.
3. Choose a threshold value L_{STALL} between 0 and $L_{MOVE} - 1$.
4. Monitor the load indicator during each reference search movement, as soon as the desired velocity is reached. Readout is required at least once per fullstep. If the readout value at one fullstep is below or equal to L_{STALL} , stop the motor. *Attention: Do not read out the value within one chopper period plus 8 microseconds after toggling one of the phase polarities!*
5. If the motor stops during normal movement without hitting the mechanical stop, decrease L_{STALL} . If the stall condition is not detected at once, when the motor stalls, increase L_{STALL} .

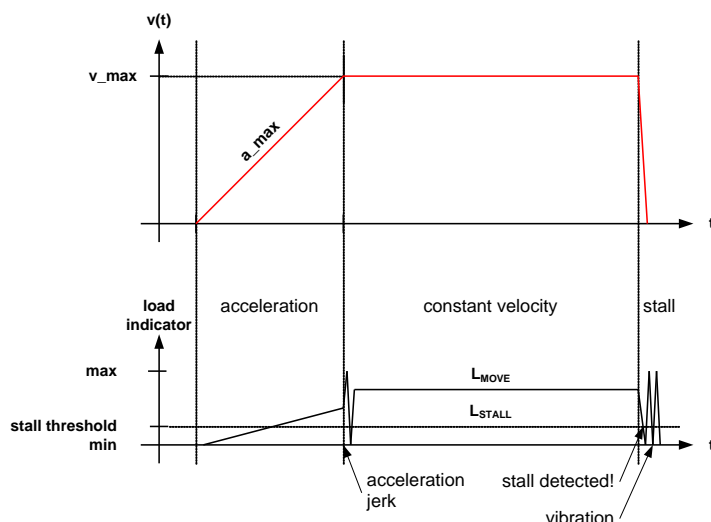

Protection Functions

Overcurrent protection and diagnosis

The TMC246 uses the current sense resistors on the low side to detect an overcurrent: Whenever a voltage above 0.61V is detected, the PWM cycle is terminated at once and all transistors of the bridge are switched off for the rest of the PWM cycle. The error counter is increased by one. If the error counter reaches 3, the bridge remains switched off for 63 PWM cycles and the error flag is read as "active". The user can clear the error condition in advance by clearing the error flag. The error counter is cleared, whenever there are more than 63 PWM cycles without overcurrent. There is one error counter for each of the low side bridges, and one for the high side. The overcurrent detection is inactive during the blank pulse time for each bridge, to suppress spikes which can occur during switching.

The high side comparator detects a short to GND or an overcurrent, whenever the voltage between VS and VT becomes higher than 0.15 V at any time, except for the blank time period which is logically ORed for both bridges. Here all transistors become switched off for the rest of the PWM cycle, because the bridge with the failure is unknown.

The overcurrent flags can be cleared by disabling and re-enabling the chip either via the ENN pin or by sending a telegram with both current control words set to "0000". In high side overcurrent conditions the user can determine which bridge sees the overcurrent, by selectively switching on only one of the bridges with each polarity (therefore the other bridge should remain programmed to "0000").

Over temperature protection and diagnosis

The circuit switches off all output power transistors during an over temperature condition. The over temperature flag should be monitored to detect this condition. The circuit resumes operation after cool down below the temperature threshold. However, operation near the over temperature threshold should be avoided, if a high lifetime is desired.

Overvoltage protection and ENN pin behavior

During disable conditions the circuit switches off all output power transistors and goes into a low current shutdown mode. All register contents is cleared to "0", and all status flags are cleared. The circuit in this condition can also stand a higher voltage, because the voltage then is not limited by the maximum power MOSFET voltage. The enable pin ENN provides a fixed threshold of $\frac{1}{2} V_{CC}$ to allow a simple overvoltage protection up to 40V using an external voltage divider (see schematic).

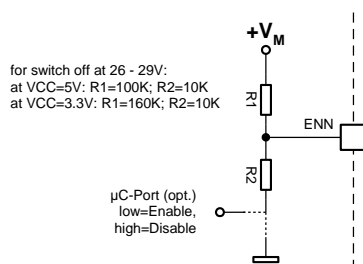

Chopper Principle

Chopper cycle / Using the mixed decay feature

The TMC246 uses a quiet fixed frequency chopper. Both coils are chopped with a phase shift of 180 degrees. The mixed decay option is realized as a self stabilizing system (pat. fi.), by shortening the fast decay phase, if the ON phase becomes longer. It is advised to enable the mixed decay for each phase during the second half of each microstepping half-wave, when the current is meant to decrease. This leads to less motor resonance, especially at medium velocities. With low velocities or during standstill mixed decay should be switched off. In applications requiring high resolution, or using low inductivity motors, the mixed decay mode can also be enabled continuously, to reduce the minimum motor current which can be achieved. When mixed decay mode is continuously on or when using high inductivity motors at low supply voltage, it is advised to raise the chopper frequency to minimum 36kHz, because the half chopper frequency could become audible under these conditions.

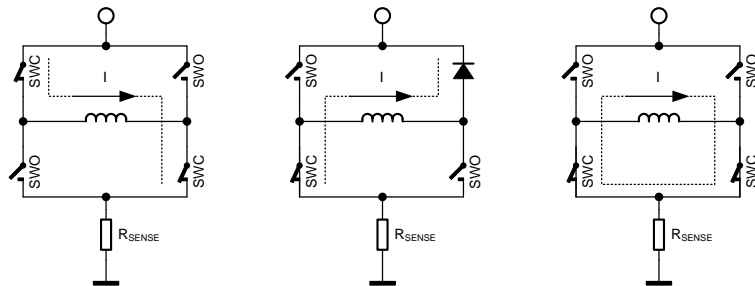

On phase:
Current flows in target direction

Fast decay phase:
Current flows back into power supply

Slow decay phase:
Current re-circulation

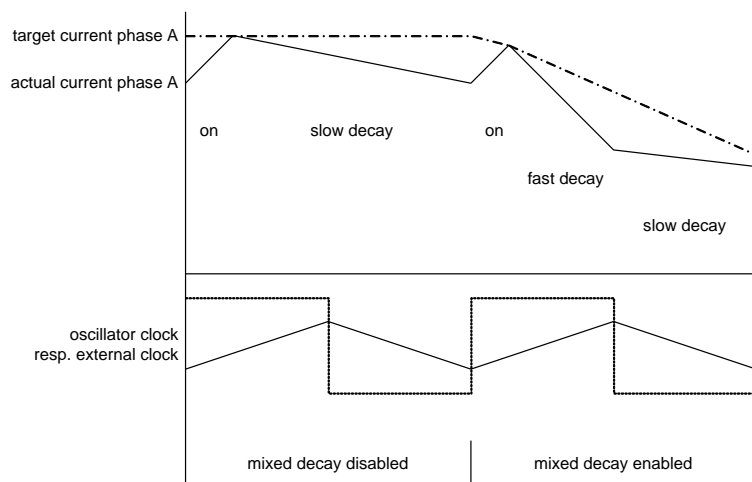

When polarity is changed on one bridge, the PWM cycle on that bridge becomes restarted at once.

Fast decay switches off both upper transistors, while enabling the lower transistor opposite to the selected polarity. Slow decay always enables both lower side transistors.

Adapting the sine wave for smooth motor operation

After reaching the target current in each chopper cycle, both, the slow decay and the fast decay cycle reduce the current by some amount. Especially the fast decay cycle has a larger impact. Thus, the medium coil current always is a bit lower than the target current. This leads to a flat line in the current shape flowing through the motor. It can be corrected, by applying an offset to the sine shape. In mixed decay operation via SPI, an offset of 1 does the job for most motors.

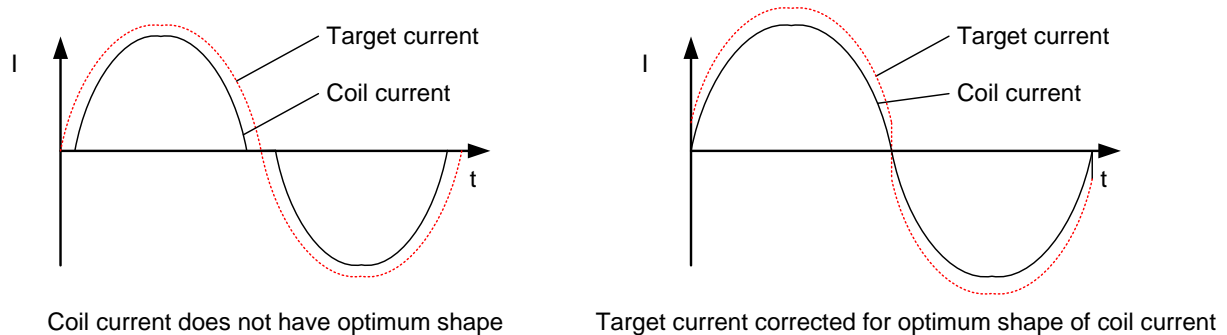

Blank Time

The TMC246 uses a digital blanking pulse for the current chopper comparators. This prevents current spikes, which can occur during switching action due to capacitive loading, from terminating the chopper cycle. The lowest possible blanking time gives the best results for microstepping: A long blank time leads to a long minimum turn-on time, thus giving an increased lower limit for the current. Please remark, that the blank time should cover both, switch-off time of the lower side transistors and turn-on time of the upper side transistors plus some time for the current to settle. Thus the complete switching duration should never exceed 1.5 μ s.

The TMC246 allows adapting the blank time to the load conditions and to the selected slope in four steps (the effective resulting blank times are about 200ns shorter in the non-A-type):

Blank time settings

BL2	BL1	Typical blank time
GND	GND	0.6 μ s
GND	VCC	0.9 μ s
VCC	GND	1.2 μ s
VCC	VCC	1.5 μ s

Classical non-SPI control mode (stand alone mode)

The driver can be controlled by analog current control signals and digital phase signals. To enable this mode, tie pin SPE to GND. In this mode, the SPI interface is disabled and the SPI input pins have alternate functions. The internal DACs are forced to "1111".

Pin functions in stand alone mode

Pin	Stand alone mode name	Function in stand alone mode
SPE	(GND)	Tie to GND to enable stand alone mode
ANN	MDAN	Enable mixed decay for bridge A (low = enable)
SCK	MDBN	Enable mixed decay for bridge B (low = enable)
SDI	PHA	Polarity bridge A (low = current flow from output OA1 to OA2)
CSN	PHB	Polarity bridge B (low = current flow from output OB1 to OB2)
SDO	ERR	Error output (high = overcurrent on any bridge, or overtemperature). In this mode, the pin is never tristated.
ENN	ENN	Standby mode (high active), high causes a low power mode of the device. Setting this pin high also resets all error conditions.
INA, INB	INA, INB	Current control for bridge A, resp. bridge B. Refer to AGND. The sense resistor trip voltage is 0.34V when the input voltage is 2.0V. Maximum input voltage is 3.0V.

Input signals for microstep control in stand alone mode

Attention: When transferring these waves to SPI operation, please remark, that the mixed decay bits are inverted when compared to stand alone mode.

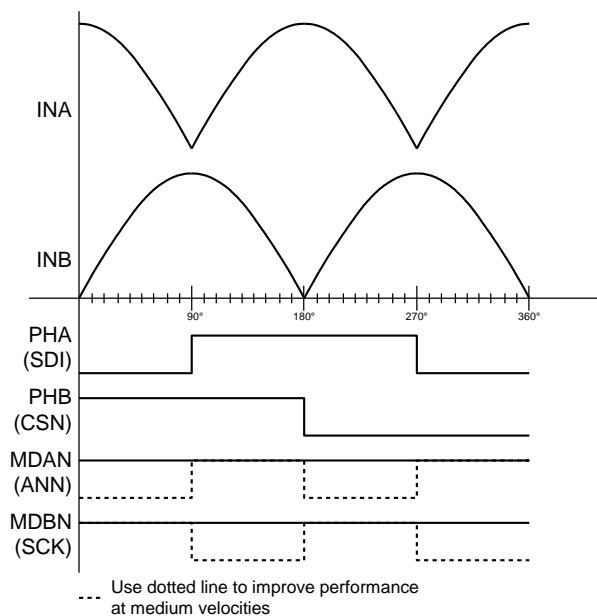

Calculation of the external components

Sense Resistor

Choose an appropriate sense resistor (R_S) to set the desired motor current. The maximum motor current is reached, when the coil current setting is programmed to "1111". This results in a current sense trip voltage of 0.34V when the internal reference or a reference voltage of 2V is used.

When operating your motor in fullstep mode, the maximum motor current is as specified by the manufacturer. When operating in sinestep mode, multiply this value by 1.41 for the maximum current (I_{max}).

$$R_S = V_{TRIP} / I_{max}$$

In a typical application:

$$R_S = 0.34V / I_{max}$$

R_S : Current sense resistor of bridge A, B
 V_{TRIP} : Programmed trip voltage of the current sense comparators
 I_{max} : Desired maximum coil current

Examples for sense resistor settings

R_S	I_{max}
0.47 Ω	723mA
0.43 Ω	790mA
0.39 Ω	870mA
0.33 Ω	1030mA
0.27 Ω	1259mA
0.22 Ω	1545mA

High side overcurrent detection resistor R_{SH}

The TMC246 detects an overcurrent to ground, when the voltage between VS and VT exceeds 150mV. The high side overcurrent detection resistor should be chosen in a way that 100mV voltage drop are not exceeded between VS and VT, when both coils draw the maximum current. In a sinestep application, this is when sine and cosine wave have their highest sum, i.e. at 45 degrees, corresponding to 1.41 times the maximum current setting for one coil. In a fullstep application this is the double coil current.

In a microstep application:

$$R_{SH} = 0.1V / (1.41 \times I_{max})$$

In a fullstep application:

$$R_{SH} = 0.1V / (2 \times I_{max})$$

R_{SH} : High side overcurrent detection resistor
 I_{max} : Maximum coil current

However, if the user desires to use higher resistance values, a voltage divider in the range of 10 Ω to 100 Ω can be used for VT. This might also be desired to limit the peak short to GND current, as described in the following chapter.

Attention: A careful PCB layout is required for the sense resistor traces and for the R_{SH} traces.

Making the circuit short circuit proof

In practical applications, a short circuit does not describe a static condition, but can be of very different nature. It typically involves inductive, resistive and capacitive components. Worst events are unclamped switching events, because huge voltages can build up in inductive components and result in a high energy spark going into the driver, which can destroy the power transistors. The same is true when disconnecting a motor during operation: Never disconnect the motor during operation!

There is no absolute protection against random short circuit conditions, but pre-cautions can be taken to improve robustness of the circuit:

In a short condition, the current can become very high before it is interrupted by the short detection, due to the blanking during switching and internal delays. The high-side transistors allows up to 10A flowing for the selected blank time. The lower the external inductivity, the faster the current climbs. If inductive components are involved in the short, the same current will shoot through the low-side resistor and cause a high negative voltage spike at the sense resistor. Both, the high current and the voltage spikes are a danger for the driver.

Thus there are a two things to be done, if short circuits are expected:

1. Protect SRA/SRB inputs using a series resistance
2. Increase R_{SH} to limit maximum transistor current: Use same value as for sense resistors
3. Use as short as possible blank time

The second measure effectively limits short circuit current, because the upper driver transistor with its fixed ON gate voltage of 7V forms a constant current source together with its internal resistance and R_{SH} . A positive side effect is, that only one type of low ohmic resistor is required. The drawback is, that power dissipation increases slightly. A high side short detection resistor of 0.33 Ohms limits maximum high side transistor current to typically 4A. The schematic shows the modifications to be done.

However, the effectiveness of these measures should be tested in the given application.

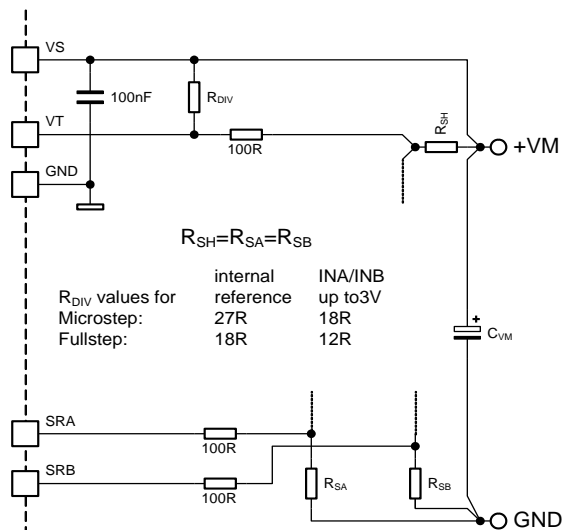

Oscillator Capacitor

The PWM oscillator frequency can be set by an external capacitor. The internal oscillator uses a 28kΩ resistor to charge / discharge the external capacitor to a trip voltage of 2/3 Vcc respectively 1/3 Vcc. It can be overdriven using an external CMOS level square wave signal. Do not set the frequency higher than 100kHz and do not leave the OSC terminal open! The two bridges are chopped with a phase shift of 180 degrees at the positive and at the negative edge of the clock signal.

$$f_{osc} \approx \frac{1}{40 \mu s \times C_{osc} [nF]}$$

f_{osc}: PWM oscillator frequency
C_{osc}: Oscillator capacitor in nF

Table of oscillator frequencies

f _{osc} typ.	C _{osc}
16.7kHz	1.5nF
20.8kHz	1.2nF
25.0kHz	1.0nF
30.5kHz	820pF
36.8kHz	680pF
44.6kHz	560pF

Please remark, that an unnecessary high frequency leads to high switching losses in the power transistors and in the motor. For most applications a chopper frequency slightly above audible range is sufficient. When audible noise occurs in an application, especially with mixed decay continuously enabled, the chopper frequency should be two times the audible range. For most applications we recommend a frequency of 36.8kHz.

Pullup resistors on unused inputs

The digital inputs all have integrated pull-up resistors, except for the ENN input, which is in fact an analog input. Thus, there are no external pull-up resistors required for unused digital inputs which are meant to be positive.

Power supply sequencing considerations

Upon power up, the driver initializes and switches off the bridge power transistors. However, in order for the internal startup logic to work properly, the Vcc supply voltage has to be at least 1.0V, respectively, the Vs supply voltage has to be at least 5.0V. When Vs goes up with Vcc at 0V, a medium current temporary cross conduction of the power stage can result at supply voltages between 2.4V and 4.8V. While this does no harm to the driver, it may hinder the power supply from coming up properly, depending on the power supply start up behavior.

In order to prevent this from occurring, either use a dual voltage power supply, or use a local regulator, generating the 5V or 3.3V Vcc voltage.

Please pay attention to the local regulator start up voltage: Some newer switching regulators do not start before the input voltage has reached 5V. Therefore it is recommended to use a standard linear regulator like 7805 series or LM317 or a low drop regulator or a switching regulator like the LM2595, starting at relatively low input voltages.

Slope Control Resistor

The output-voltage slope of the full bridge outputs can be controlled to reduce noise on the power supply and on the motor lines and thus electromagnetic emission of the circuit. It is controlled by an external resistor at the SLP pin.

Operational range:

$$0\text{k}\Omega \leq R_{\text{SLP}} \leq 100\text{k}\Omega$$

The SLP-pin can directly be connected to AGND for the fastest output-voltage slope (respectively maximum output current). In most applications a minimum external resistance of 10 K Ω is recommended to avoid unnecessary high switching spikes.

Only for non-A-types the slope on the lower transistors is fixed (corresponding to a 5K Ω to 10K Ω slope control resistor). For applications where electromagnetic emission is very critical, it might be necessary to add additional LC (or capacitor only) filtering on the motor connections.

For these applications emission is lower, if only slow decay operation is used.

Please remark, that there is a tradeoff between reduced electromagnetic emissions (slow slope) and high efficiency because of low dynamic losses (fast slope).

The following table and graph depict typical behavior measured from 15% of output voltage to 85% of output voltage. However, the actual values measured in an application depend on multiple parameters and may stray in a user application.

Example for slope settings

$t_{\text{SLP typ.}}$	R_{SLP}
30ns	2.2K Ω
60ns	10K Ω
110ns	22K Ω
245ns	51K Ω
460ns	100K Ω

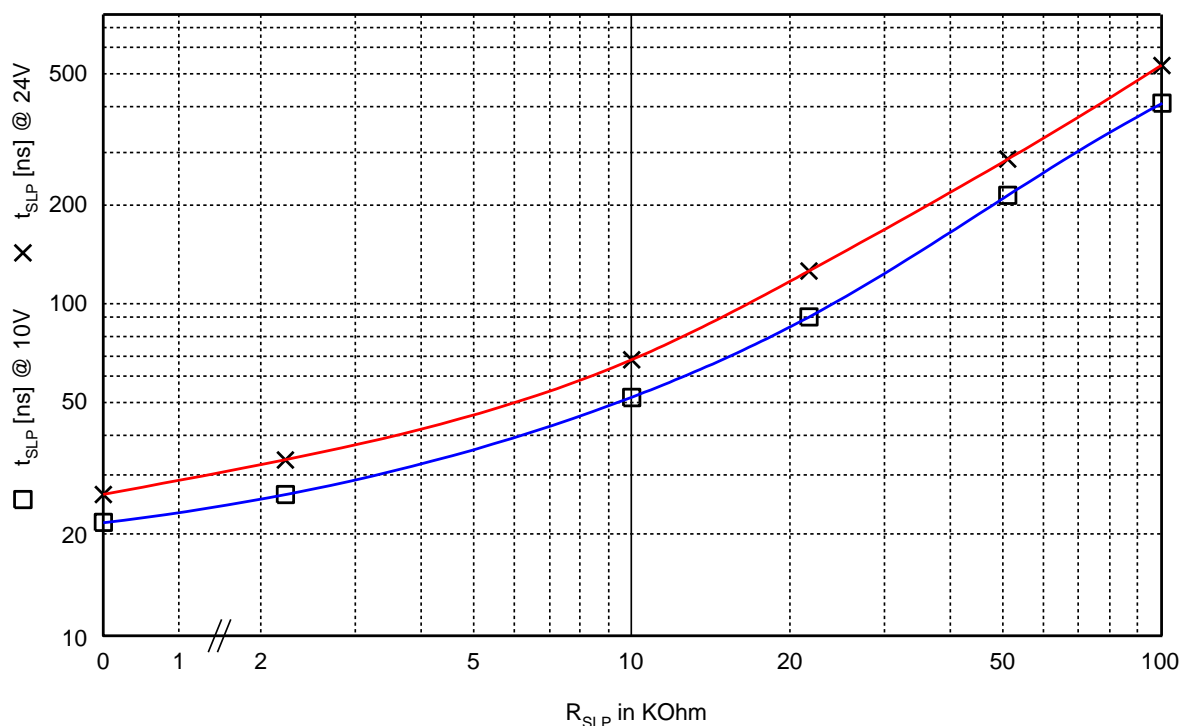

Absolute Maximum Ratings

The maximum ratings may not be exceeded under any circumstances.

Symbol	Parameter	Min	Max	Unit
V _S	Supply voltage (A-type/B-type)	-0.3	36	V
V _S	Supply voltage (non-A/B-type)	-0.3	30	V
V _{MD}	Supply and bridge voltage max. 20000s (non-A-type: device disabled)		40	V
V _{TR}	Power transistor voltage V _{OA} -V _{BRA} , V _{OB} -V _{BRB} , V _{SA} -V _{OA} , V _{SB} -V _{OB} (A/B-type)		40	V
V _{TR}	Power transistor voltage V _{OA} -V _{BRA} , V _{OB} -V _{BRB} , V _{SA} -V _{OA} , V _{SB} -V _{OB} (non-A/B-type)		30	V
V _{CC}	Logic supply voltage	-0.5	6.0	V
I _{OP}	Output peak current (10µs pulse)		+/-7	A
I _{OC}	Output current (continuous, per bridge)	T _A ≤ 85°C	1500	mA
		T _A ≤ 105°C	1000	
		T _A ≤ 125°C	800	
V _I	Logic input voltage	-0.3	V _{CC} +0.3V	V
V _{IA}	Analog input voltage	-0.3	V _{CC} +0.3V	V
I _{IO}	Maximum current to / from digital pins and analog inputs		+/-10	mA
V _{VT}	Short-to-ground detector input voltage	V _S -1V	V _S +0.3V	V
T _J	Junction temperature	-40	150 (1)	°C
T _{STG}	Storage temperature	-55	150	°C

(1) Internally limited

Electrical Characteristics

Operational Range

Symbol	Parameter	Min	Max	Unit
T _{AI}	Ambient temperature industrial (1)	-25	125	°C
T _{AA}	Ambient temperature automotive	-40	125	°C
T _J	Junction temperature	-40	140	°C
V _S	Bridge supply voltage (A-type/B-type)	7	34	V
V _S	Bridge supply voltage (non-A/B-type)	7	28.5	V
V _{CC}	Logic supply voltage	3.0	5.5	V
f _{CLK}	Chopper clock frequency		50	kHz
R _{SLP}	Slope control resistor	0	110	KΩ

(1) The circuit can be operated up to 140°C, but output power derates.

DC Characteristics

DC characteristics contain the spread of values guaranteed within the specified supply voltage and temperature range unless otherwise specified. Typical characteristics represent the average value of all parts.

Logic supply voltage: $V_{CC} = 3.0\text{ V} \dots 5.5\text{ V}$, Junction temperature: $T_J = -40^\circ\text{C} \dots 150^\circ\text{C}$,
 Bridge supply voltage: $V_S = 7\text{ V} \dots 34\text{ V}$
 (unless otherwise specified)

Symbol	Parameter	Conditions	Min	Typ	Max	Unit
$R_{OUT,Sink}$	R_{DSON} of sink-FET (A-type)	$T_J = 25^\circ\text{C}$ $V_S \geq 8\text{V}$		0.12	0.19	Ω
$R_{OUT,Source}$	R_{DSON} of source-FET (A-type)			0.22	0.36	Ω
$R_{OUT,Sink}$	R_{DSON} of sink-FET max. (A-type)	$T_J = 150^\circ\text{C}$ $V_S \geq 8\text{V}$		0.20	0.26	Ω
$R_{OUT,Source}$	R_{DSON} of source-FET max. (A-Type)			0.37	0.47	Ω
$R_{OUT,Sink}$	R_{DSON} of sink-FET (B-type)	$T_J = 25^\circ\text{C}$ $V_S \geq 8\text{V}$		0.10	0.14	Ω
$R_{OUT,Source}$	R_{DSON} of source-FET (B-type)			0.17	0.23	Ω
$R_{OUT,Sink}$	R_{DSON} of sink-FET max. (B-type)	$T_J = 150^\circ\text{C}$ $V_S \geq 8\text{V}$		0.16	0.23	Ω
$R_{OUT,Source}$	R_{DSON} of source-FET max. (B-Type)			0.28	0.38	Ω
V_{DIO}	Diode forward voltages of O_{xx} MOSFET diodes (A-type)	$T_J = 25^\circ\text{C}$ $I_{OXX} = 1.05\text{A}$		0.84	1.21	V
V_{DIO}	Diode forward voltages of O_{xx} MOSFET diodes (B-type)	$T_J = 25^\circ\text{C}$ $I_{OXX} = 1.05\text{A}$		0.77	1.2	V
V_{CCUV}	VCC undervoltage		2.5	2.7	2.9	V
V_{CCOK}	VCC voltage o.k.		2.7	2.9	3.0	V
I_{CC}	VCC supply current	$f_{osc} = 25\text{ kHz}$		0.85	1.35	mA
I_{CCSTB}	VCC supply current standby			0.45	0.75	mA
I_{CCSD}	VCC supply current shutdown	$ENN = 1$		37	70	μA
V_{SUV}	VS undervoltage		5.5	5.9	6.2	V
V_{CCOK}	VS voltage o.k.		6.1	6.4	6.7	V
I_{SSM}	VS supply current with fastest slope setting (static state)	$V_S = 14\text{V}$, $R_{SLP} = 0\text{K}$		6		mA
I_{SSD}	VS supply current shutdown or standby	$V_S = 14\text{V}$		28	50	μA
V_{IH}	High input voltage (SDI, SCK, CSN, BL1, BL2, SPE, ANN)		2.2		$V_{CC} + 0.3\text{ V}$	V
V_{IL}	Low input voltage (SDI, SCK, CSN, BL1, BL2, SPE, ANN)		-0.3		0.7	V
V_{IHYS}	Input voltage hysteresis (SDI, SCK, CSN, BL1, BL2, SPE, ANN)		100	300	500	mV
V_{OH}	High output voltage (output SDO)	$-I_{OH} = 1\text{mA}$	$V_{CC} - 0.6$	$V_{CC} - 0.2$	V_{CC}	V
V_{OL}	Low output voltage (output SDO)	$I_{OL} = 1\text{mA}$	0	0.1	0.4	V

-I _{ISL}	Low input current (SDI, SCK, CSN, BL1, BL2, SPE, ANN)	V _I = 0 V _{CC} = 3.3V V _{CC} = 5.0V	2	10 25	70	μA μA μA
V _{ENNH}	High input voltage threshold (input ENN)			1/2 V _{CC}		
V _{EHYS}	Input voltage hysteresis (input ENN)			0.1 V _{ENNH}		
V _{OSCH}	High input voltage threshold (input OSC)		tbd	2/3 V _{CC}	tbd	V
V _{OSCL}	Low input voltage threshold (input OSC)		tbd	1/3 V _{CC}	tbd	V
V _{VTD}	VT threshold voltage (referenced to VS)		-130	-155	-180	mV
V _{TRIP}	SRA / SRB voltage at DAC="1111"	internal ref. or 2V at INA / INB	315	350	385	mV
V _{SRS}	SRA / SRB overcurrent detection threshold		570	615	660	mV
V _{SROFFS}	SRA / SRB comparator offset voltage		-10	0	10	mV
R _{INAB}	INA / INB input resistance	V _{in} ≤ 3 V	175	264	300	kΩ

AC Characteristics

AC characteristics contain the spread of values guaranteed within the specified supply voltage and temperature range unless otherwise specified. Typical characteristics represent the average value of all parts.

Logic supply voltage: V_{CC} = 5.0V,
Ambient temperature: T_A = 27°C

Bridge supply voltage: V_S = 14.0V,

Symbol	Parameter	Conditions	Min	Typ	Max	Unit
f _{OSC}	Oscillator frequency using internal oscillator	C _{OSC} = 1nF ±1%	20	25	31	kHz
t _{RS} , t _{FS}	Rise and fall time of outputs O _{xx} with R _{SLP} =0	V _o 15% to 85% I _{oXX} = 800mA		25		ns
t _{RS} , t _{FS}	Rise and fall time of outputs O _{xx} with R _{SLP} = 25KΩ	V _o 15% to 85% I _{oXX} = 800mA		125		ns
t _{RS} , t _{FS}	Rise and fall time of outputs O _{xx} with R _{SLP} = 50KΩ	V _o 15% to 85% I _{oXX} = 800mA		250		ns
T _{BL}	Effective Blank time	BL1, BL2 = V _{CC}	1.35	1.5	1.65	μs
T _{ONMIN}	Minimum PWM on-time	BL1, BL2 = GND		0.7		μs

Thermal Protection

Symbol	Parameter	Conditions	Min	Typ	Max	Unit
T _{JOT}	Thermal shutdown		145	155	165	°C
T _{JOTHYS}	T _{JOT} hysteresis			15		°C
T _{JWT}	Prewarning temperature		135	145	155	°C
T _{JWTHYS}	T _{JWT} hysteresis			15		°C

Thermal Characteristics

Symbol	Parameter	Conditions	Typ	Unit
R _{THA12}	Thermal resistance bridge transistor junction to ambient, one bridge chopping, fixed polarity	soldered to 2 layer PCB	88	°K/W
R _{THA22}	Thermal resistance bridge transistor junction to ambient, two bridges chopping, fixed polarity	soldered to 2 layer PCB	68	°K/W
R _{THA14}	Thermal resistance bridge transistor junction to ambient, one bridge chopping, fixed polarity	soldered to 4 layer PCB (pessimistic)	84	°K/W
R _{THA24}	Thermal resistance bridge transistor junction to ambient, two bridges chopping, fixed polarity	soldered to 4 layer PCB (pessimistic)	51	°K/W

Typical Power Dissipation at high load / high temperature

Coil: $L_W = 10\text{mH}$, $R_W = 5.0\Omega$
 Chopping with: $t_{\text{DUTY}} = 33\% \text{ ON}$, only slow decay

Current both bridges on	Current one bridge on	Ambient temperature T_A	Motor supply voltage V_M	Slope t_{SLP}	Chopper frequency f_{CHOP}	Typ total power dissipation P_D
560 mA	-	105 °C	16 V	400 ns	25 KHz	490 mW
-	800 mA	105 °C	16 V	400 ns	25 KHz	450 mW
560 mA	-	125 °C	14 V	60ns	20 KHz	350 mW
-	800 mA	125 °C	14 V	60ns	20 KHz	340 mW
1000 mA	-	70 °C	28 V	60ns	25 KHz	1000 mW
-	1500 mA	70 °C	28 V	60ns	25 KHz	1100 mW

SPI Interface Timing

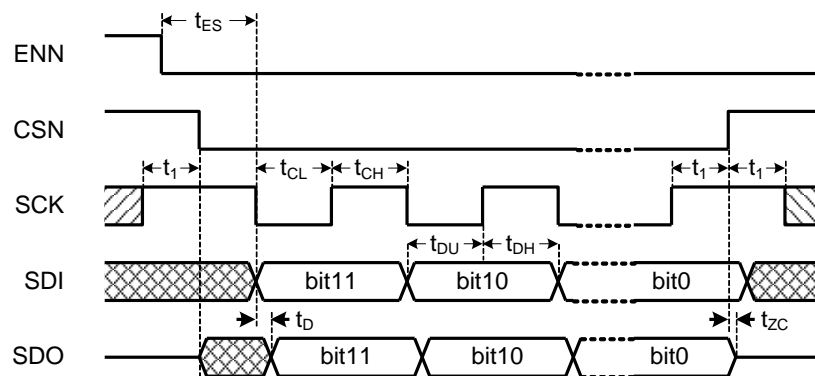

Propagation Times

($3.0\text{ V} \leq V_{CC} \leq 5.5\text{ V}$, $-40^\circ\text{C} \leq T_j \leq 150^\circ\text{C}$; $V_{IH} = 2.8\text{V}$, $V_{IL} = 0.5\text{V}$; $t_r, t_f = 10\text{ns}$; $C_L = 50\text{pF}$, unless otherwise specified)

Symbol	Parameter	Conditions	Min	Typ	Max	Unit
f_{SCK}	SCK frequency	ENN = 0	DC		4	MHz
t_1	SCK stable before and after CSN change		50			ns
t_{CH}	Width of SCK high pulse		100			ns
t_{CL}	Width of SCK low pulse		100			ns
t_{DU}	SDI setup time		40			ns
t_{DH}	SDI hold time		50			ns
t_{D}	SDO delay time	$C_L = 50\text{pF}$		40	100	ns
t_{zc}	CSN high to SDO high impedance	*)	50			ns
t_{ES}	ENN to SCK setup time		30			μs
t_{PD}	CSN high to OA / OB output polarity change delay	**)		3	$t_{\text{osc}} + 4$	μs
t_{LD}	Load indicator valid after OA / OB output polarity change			5	7	μs

*) SDO is tristated whenever ENN is inactive (high) or CSN is inactive (high).

**) Whenever the PHA / PHB polarity is changed, the chopper is restarted for that phase. However, the chopper does not switch on, when the SRA resp. SRB comparator threshold is exceeded upon the start of a chopper period.

Using the SPI interface

The SPI interface allows either cascading of multiple devices, giving a longer shift register, or working with a separate chip select signal for each device, paralleling all other lines. Even when there is only one device attached to a CPU, the CPU can communicate with it using a 16 bit transmission. In this case, the upper 4 bits are dummy bits.

SPI Filter

To prevent spikes from changing the SPI settings, SPI data words are only accepted, if their length is at least 12 bit.

ESD Protection

Please be aware, that the TMC246 is an ESD sensitive device due to integrated high performance MOS transistors.



ESD sensitive device

If the ICs are manually handled before / during soldering, special precautions have to be taken to avoid ESD voltages above 100V HBM (Human body model). For automated SMD equipment the internal device protection is specified with 1000V CDM (charged device model), tbf.

When soldered to the application board, all inputs and outputs withstand at least 1000V HBM.

Application Note: Extending the Microstep Resolution

For some applications it might be desired to have a higher microstep resolution, while keeping the advantages of control via the serial interface. The following schematic shows a solution, which adds two LSBs by selectively pulling up the SRA / SRB pin by a small voltage difference. Please remark, that the lower two bits are inverted in the depicted circuit. A full scale sense voltage of 340mV is assumed. The circuit still takes advantage of completely switching off of the coils when the internal DAC bits are set to "0000". This results in the following comparator trip voltages:

Current setting (MSB first)	Trip voltage
0000xx	0 V
000111	5.8 mV
000110	11.5 mV
000101	17.3 mV
000100	23 mV
...	
111101	334.2 mV
111100	340 mV

SPI bit	15	14	13	12	11	10	9	8
DAC bit	/B1	/B0	/A1	/A0	MDA	A5	A4	A3
SPI bit	7	6	5	4	3	2	1	0
DAC bit	A2	PHA	MDB	B5	B4	B3	B2	PHB

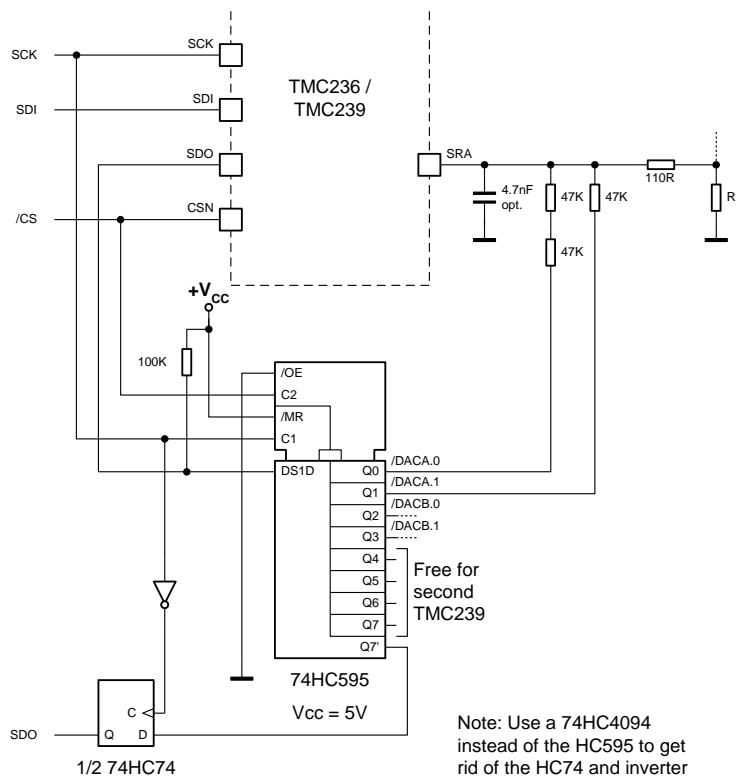

Please see the FAQ document for more application information.

Documentation Revision

Version	Author <small>BD= Bernhard Dwersteg</small>	Description
V1.00	BD	First version, Sept. 2003
V2.04	BD	Added power supply sequencing considerations
V2.05	BD	Adapted style, added info on chopper cycle
V2.06	BD	Corrected ENN timing in SPI section
V2.10	BD	Added IC revision TMC246B with improved MOSFETs – see chapter “Electrical Characteristics” for any differences.
V2.11	BD	Added TMC246B to package code list
V2.12	BD	Updated Logo

ⁱ SPI is a trademark of Motorola