

TMCM-3212 CANopen® Firmware Manual

Firmware Version V3.22 | Document Revision V1.05 • 2019-FEB-13

The TMCM-3212 is a three axes controller/driver module for 2-phase bipolar stepper motors with separate differential encoder and separate home and stop switch inputs for each axis. Dynamic current control, and quiet, smooth and efficient operation are combined with StealthChop™, Dc-Step™, StallGuard2™ and CoolStep™ features. The module offers four analog or digital inputs as well as four digital outputs in combination with a break chopper unit.

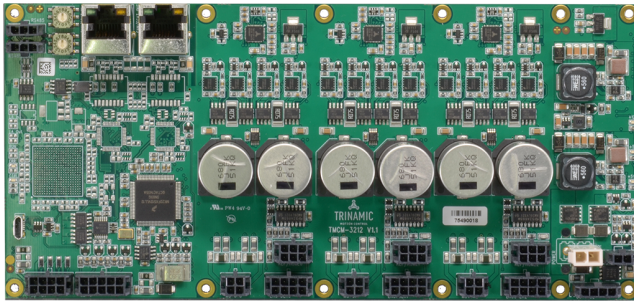

Features

- 3-Axes Stepper Motor Control
- CANopen® CiA-402 Drive Profile
- Encoder Support
- SixPoint™ ramps
- CoolStep™
- DcStep™
- StallGuard2™
- StealthChop™

Applications

- Laboratory Automation
- Manufacturing
- Semiconductor Handling
- Robotics
- Factory Automation
- Test & Measurement
- Life Science
- Biotechnology
- Liquid Handling

Simplified Block Diagram

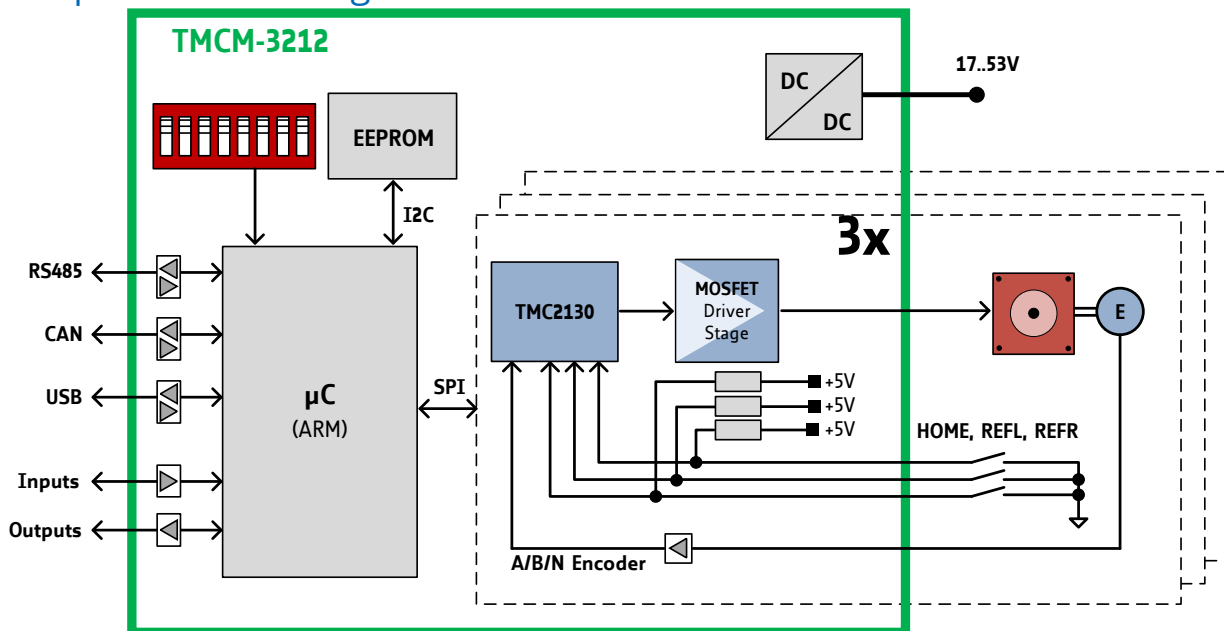

Contents

1	Preface	7
1.1	General Features of this CANopen Implementation	7
1.2	Abbreviations used in this Manual	8
1.3	Firmware Update	8
1.4	Trinamic's unique Features — easy to use with CANopen®	9
1.4.1	StallGuard2™	9
1.4.2	CoolStep™	9
1.5	SixPoint™ Motion Controller	10
2	Communication	12
2.1	Reference Model	12
2.2	NMT State Machine	14
2.3	Device Model	15
2.4	Object Dictionary	16
2.4.1	Object Indices on Multi-Axis Modules	17
3	Communication Area	18
3.1	Detailed Object Specifications	18
3.1.1	Object 1000 _h : Device Type	18
3.1.2	Object 1001 _h : Error Register	18
3.1.3	Object 1005 _h : COB-ID SYNC Message	19
3.1.4	Object 1008 _h : Manufacturer Device Name	20
3.1.5	Object 1009 _h : Manufacturer Hardware Version	20
3.1.6	Object 100A _h : Manufacturer Software Version	20
3.1.7	Object 100C _h : Guard Time	21
3.1.8	Object 100D _h : Life Time Factor	21
3.1.9	Object 1010 _h : Store Parameters	21
3.1.10	Object 1011 _h : Restore Parameters	23
3.1.11	Object 1014 _h : COB-ID Emergency Object	24
3.1.12	Object 1015 _h : Inhibit Time EMCY	24
3.1.13	Object 1016 _h : Consumer Heartbeat Time	25
3.1.14	Object 1017 _h : Producer Heartbeat Time	26
3.1.15	Object 1018 _h : Identity Object	26
3.1.16	Object 1023 _h : OS Command	27
3.1.17	Object 1029 _h : Error Behaviour	27
3.1.18	Objects 1400 _h – 1403 _h : Receive PDO Communication Parameter	28
3.1.19	Objects 1600 _h – 1603 _h : Receive PDO Mapping Parameter	29
3.1.20	Objects 1800 _h – 1803 _h : Transmit PDO Communication Parameter	30
3.1.21	Objects 1A00 _h – 1A03 _h : Transmit PDO Mapping Parameter	31
4	Manufacturer specific Area	33
4.1	Objects related to CoolStep™	33
4.2	Detailed Object Specifications	36
4.2.1	Object 2000 _h : Microstep Resolution	36
4.2.2	Object 2001 _h : Fullstep Resolution	36
4.2.3	Object 2002 _h : Brake Delay Times	36
4.2.4	Object 2003 _h : Maximum Current	37
4.2.5	Object 2004 _h : Standby Current	38
4.2.6	Object 2005 _h : Limit Switches	38
4.2.7	Object 200A _h : Enable Drive Delay Time	39
4.2.8	Object 200B _h : Encoder Parameters	39
4.2.9	Object 200C _h : Brake Current Feed	40



4.2.10	Object 200F _h : Encoder N Channel Latch	40
4.2.11	Object 2010 _h : Profile Start Velocity	41
4.2.12	Object 2011 _h : Profile A1	41
4.2.13	Object 2012 _h : Profile V1	42
4.2.14	Object 2013 _h : Profile D1	42
4.2.15	Object 2015 _h : Ramp Wait Time	42
4.2.16	Object 2089 _h : Setting Delay	43
4.2.17	Object 208C _h : Velocity Dimension Index	43
4.2.18	Object 208E _h : Acceleration Dimension Index	44
4.2.19	Object 2092 _h : Chopper Blank Time	44
4.2.20	Object 2093 _h : Chopper Mode	45
4.2.21	Object 2094 _h : Chopper Hysteresis Decrement	45
4.2.22	Object 2095 _h : Chopper Hysteresis End	46
4.2.23	Object 2096 _h : Chopper Hysteresis Start	46
4.2.24	Object 2097 _h : Chopper Off Time	46
4.2.25	Object 2098 _h : Smart Energy Current Minimum	47
4.2.26	Object 2099 _h : Smart Energy Current Down Step	47
4.2.27	Object 209A _h : Smart Energy Hysteresis	48
4.2.28	Object 209B _h : Smart Energy Current Up Step	48
4.2.29	Object 209C _h : Smart Energy Hysteresis Start	49
4.2.30	Object 209D _h : Smart Energy Filter Enable	49
4.2.31	Object 209E _h : StallGuard2 Threshold	50
4.2.32	Object 20A1 _h : Short Protection Disable	50
4.2.33	Object 20A3 _h : Vsense	51
4.2.34	Object 20A4 _h : Stop on Stall	51
4.2.35	Object 20A5 _h : Smart Energy Threshold Speed	52
4.2.36	Object 20B0 _h : PWM Threshold Speed	52
4.2.37	Object 20B1 _h : PWM Gradient	52
4.2.38	Object 20B2 _h : PWM Amplitude	53
4.2.39	Object 20B3 _h : DcStep Minimum Speed	53
4.2.40	Object 20B4 _h : DcStep Time	54
4.2.41	Object 20B5 _h : DcStep StallGuard	54
4.2.42	Object 20B6 _h : Fullstep Threshold Speed	55
4.2.43	Object 20B7 _h : High Speed Chopper Mode	55
4.2.44	Object 20B8 _h : High Speed Fullstep Mode	55
4.2.45	Object 20B9 _h : Power Down Ramp	56
4.2.46	Object 2100 _h : Home Offset Display	56
4.2.47	Object 2101 _h : Actual Load Value	57
4.2.48	Object 2102 _h : Driver Error Flags	57
4.2.49	Object 2107 _h : Microstep Resolution Display	58
4.2.50	Object 210B _h : Step Counter	58
4.2.51	Object 2121 _h : PWM Scale Value	59
4.2.52	Object 2122 _h : Measured Velocity	59
4.2.53	Object 2700 _h : TMCL Direct Communication	59
4.2.54	Object 2701 _h : Manufacturer Specific Mode	60
4.2.55	Object 2702 _h : Device Digital Inputs	60
4.2.56	Object 2703 _h : Device Digital Outputs	61
4.2.57	Object 2704 _h : CAN Bit Rate	62
4.2.58	Object 2705 _h : Node ID	63
4.2.59	Object 2706 _h : Store	63
4.2.60	Object 2707 _h : CAN Bit Rate Load	64
4.2.61	Object 2708 _h : Node ID Load	64
4.2.62	Object 270E _h : Device Analog Inputs	64



5	Profile specific Area	66
5.1	Detailed Object Specifications	66
5.1.1	Object 605A _h : Quick Stop Option Code	66
5.1.2	Object 605B _h : Shutdown Option Code	67
5.1.3	Object 605C _h : Disable Operation Option Code	68
5.1.4	Object 605D _h : Halt Option Code	68
5.1.5	Object 605E _h : Fault Reaction Option Code	69
5.1.6	Object 6060 _h : Modes of Operation	69
5.1.7	Object 6061 _h : Modes of Operation Display	70
5.1.8	Object 606A _h : Sensor Selection Code	71
5.1.9	Object 608F _h : Position Encoder Resolution	72
5.1.10	Object 60FD _h : Digital Inputs	72
5.1.11	Object 6502 _h : Supported Drive Modes	73
6	Profile Position Mode	75
6.1	Detailed Object Specifications	75
6.1.1	Object 6040 _h : Control Word	76
6.1.2	Object 6041 _h : Status Word	77
6.1.3	Object 6062 _h : Position Demand Value	78
6.1.4	Object 6063 _h : Position Actual Internal Value	79
6.1.5	Object 6064 _h : Position Actual Value	79
6.1.6	Object 6065 _h : Following Error Window	80
6.1.7	Object 6067 _h : Position Window	80
6.1.8	Object 6068 _h : Position Window Time	81
6.1.9	Object 606C _h : Velocity Actual Value	81
6.1.10	Object 607A _h : Target Position	82
6.1.11	Object 607D _h : Software Position Limit	82
6.1.12	Object 6081 _h : Profile Velocity	83
6.1.13	Object 6082 _h : End Velocity	83
6.1.14	Object 6083 _h : Profile Acceleration	84
6.1.15	Object 6084 _h : Profile Deceleration	84
6.1.16	Object 6085 _h : Quick Stop Deceleration	84
6.1.17	Object 60F2 _h : Positioning Option Code	85
6.2	How to move a Motor in pp Mode	86
7	Profile Velocity Mode	87
7.1	Detailed Object Specifications	87
7.1.1	Object 6040 _h : Control Word	87
7.1.2	Object 6041 _h : Status Word	88
7.1.3	Object 6062 _h : Position Demand Value	90
7.1.4	Object 6063 _h : Position Actual Internal Value	90
7.1.5	Object 6064 _h : Position Actual Value	91
7.1.6	Object 6065 _h : Following Error Window	91
7.1.7	Object 606C _h : Velocity Actual Value	92
7.1.8	Object 607D _h : Software Position Limit	92
7.1.9	Object 6083 _h : Profile Acceleration	93
7.1.10	Object 6085 _h : Quick Stop Deceleration	93
7.1.11	Object 60FF _h : Target Velocity	93
7.2	How to move a Motor in pv Mode	94



8 Homing Mode	95
8.1 Homing Methods	96
8.1.1 Homing Method 1: Homing on negative Limit Switch and Index Pulse	96
8.1.2 Homing Method 2: Homing on positive Limit Switch and Index Pulse	97
8.1.3 Homing Method 3: Homing on positive Home Switch and Index Pulse	97
8.1.4 Homing Method 5: Homing on negative Home Switch and Index Pulse	97
8.1.5 Homing Method 17: Homing on negative Limit Switch	98
8.1.6 Homing Method 18: Homing on positive Limit Switch	98
8.1.7 Homing Method 19: Homing on positive Home Switch	99
8.1.8 Homing Method 21: Homing on negative Home Switch	99
8.1.9 Homing Method 33 and 34: Homing on next Index Pulse	99
8.1.10 Homing Method 35: Current Position as Home Position	100
8.2 Detailed Object Specifications	101
8.2.1 Object 6040 _h : Control Word	101
8.2.2 Object 6041 _h : Status Word	102
8.2.3 Object 606C _h : Velocity Actual Value	103
8.2.4 Object 607C _h : Home Offset	104
8.2.5 Object 6098 _h : Homing Method	105
8.2.6 Object 6099 _h : Homing Speeds	105
8.2.7 Object 609A _h : Homing Acceleration	105
8.3 How to start a Homing in hm Mode	106
9 Cyclic synchronous Position Mode	107
9.1 Detailed Object Specifications	107
9.1.1 Object 6040 _h : Control Word	107
9.1.2 Object 6041 _h : Status Word	108
9.1.3 Object 6062 _h : Position Demand Value	110
9.1.4 Object 6063 _h : Position Actual Internal Value	110
9.1.5 Object 6064 _h : Position Actual Value	111
9.1.6 Object 606C _h : Velocity Actual Value	111
9.1.7 Object 607A _h : Target Position	111
9.1.8 Object 607D _h : Software Position Limit	112
9.1.9 Object 60B0 _h : Position Offset	112
9.1.10 Object 60C2 _h : Interpolation Time Period	113
10 Cyclic synchronous Velocity Mode	114
10.1 Detailed Object Specifications	114
10.1.1 Object 6040 _h : Control Word	114
10.1.2 Object 6041 _h : Status Word	115
10.1.3 Object 606C _h : Velocity Actual Value	117
10.1.4 Object 60FF _h : Target Velocity	117
10.1.5 Object 607D _h : Software Position Limit	117
10.1.6 Object 60B1 _h : Velocity Offset	118
10.1.7 Object 60C2 _h : Interpolation Time Period	118
11 Emergency Messages (EMCY)	120
12 Figures Index	122
13 Tables Index	123



14 Supplemental Directives	127
14.1 Producer Information	127
14.2 Copyright	127
14.3 Trademark Designations and Symbols	127
14.4 Target User	127
14.5 Disclaimer: Life Support Systems	127
14.6 Disclaimer: Intended Use	127
14.7 Collateral Documents & Tools	128
15 Revision History	129
15.1 Firmware Revision	129
15.2 Document Revision	129



1 Preface

This document specifies objects and modes of operation of the Trinamic TMCM-3212 stepper motor control module with CANopen firmware. The CANopen firmware is designed to fulfill the CANopen DS402 and DS301 standards. This manual assumes that the reader is already familiar with the basics of the CANopen protocol, defined by the DS301 and DS402 standards of the CAN-CiA. If necessary it is always possible to turn the module into a TMCL module by loading the TMCM-3212 TMCL firmware again through the USB interface, with the help of the firmware update function of the TMCL-IDE 3.0.

1.1 General Features of this CANopen Implementation

Main Characteristics

- Communication according to standard CiA-301 V4.1
- CAN bit rate: 20...1000kBit/s
- CAN ID: 11 bit
- Node ID: 1...127 (use vendor specific objects for changing the node ID)
- NMT services: NMT slave

SDO Communication

- 1 server
- Expedited transfer
- Segmented transfer
- No block transfer

PDO Communication

- Producer
- Consumer
- RPDOs
 - Axis 0: 1, 2, 3, 4
 - Axis 1: 65, 66, 67, 68
 - Axis 2: 129, 130, 131, 132
 - Transmission modes: asynchronous.
 - Dynamic mapping with max. 3 mapping entries.
 - Default mappings: according to CiA-402 for first three PDOs of each axis, manufacturer specific for other PDOs of each axis.
- TPDOs
 - Axis 0: 1, 2, 3, 4
 - Axis 1: 65, 66, 67, 68
 - Axis 2: 129, 130, 131, 132
 - Transmission modes: asynchronous, asynchronous with event timer, synchronous.
 - Dynamic mapping with max. 3 mapping entries.
 - Default mappings: according to CiA-402 for first three PDOs of each axis, manufacturer specific for other PDOs of each axis.



Further Characteristics

- SYNC: consumer (TPDOs 3, 67, 131 are synchronous PDOs)
- Emergency: producer
- RTR: supported only for node guarding/life guarding
- Heartbeat: consumer and producer

1.2 Abbreviations used in this Manual

Abbreviations	
CAN	Controller area network
CHGND	chassis ground / earth ground
COB	Communication object
FSA	Finite state automaton
FSM	Finite state machine
NMT	Network management
ID	Identifier
LSB	Least significant bit
MSB	Most significant bit
PDO	Process data object
PDS	Power drive system
RPDO	Receive process data object
SDO	Service data object
TPDO	Transmit process data object
EMCY	Emergency object
rw	Read and write
ro	Read only
hm	Homing mode
pp	Profile position mode
pv	Profile velocity mode
vm	Velocity mode

Table 1: Abbreviations used in this Manual

1.3 Firmware Update

The software running on the microprocessor consists of two parts, a boot loader and the CANopen firmware itself. Whereas the boot loader is installed during production and testing at TRINAMIC and remains untouched throughout the whole lifetime, the CANopen firmware can easily be updated by the user. The new firmware can be loaded into the module via the firmware update function of the TMCL-IDE, using the USB interface of the module.



1.4 Trinamic's unique Features — easy to use with CANopen®

1.4.1 StallGuard2™

StallGuard2™ is a high-precision sensorless load measurement using the back EMF of the coils. It can be used for stall detection as well as other uses at loads below those which stall the motor. The StallGuard2™ measurement value changes linearly over a wide range of load, velocity, and current settings. At maximum motor load, the value reaches zero or is near zero. This is the most energy-efficient point of operation for the motor.

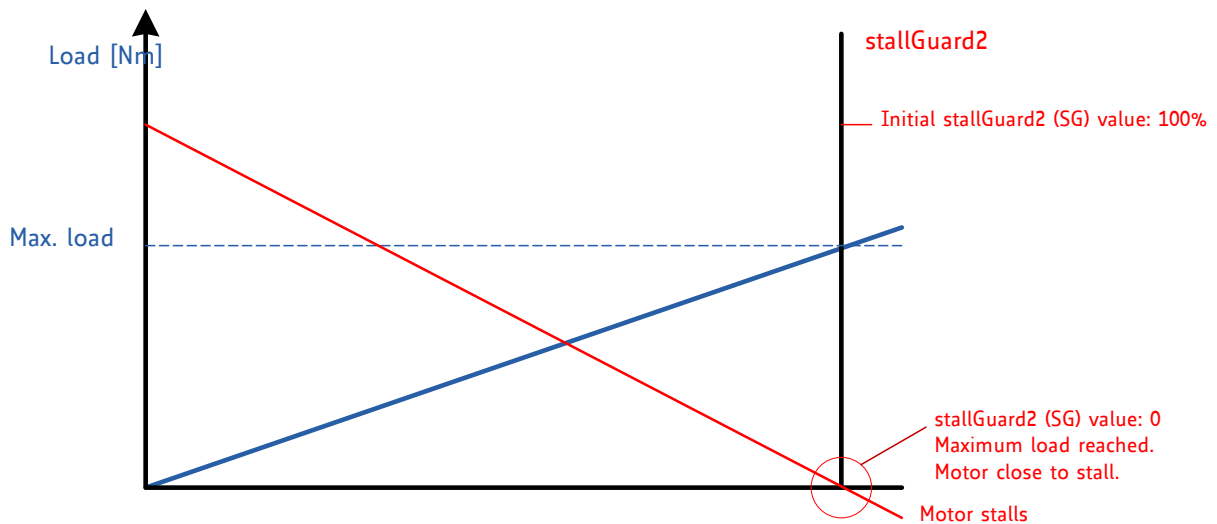

Figure 1: StallGuard2 Load Measurement as a Function of Load

1.4.2 CoolStep™

CoolStep™ is a load-adaptive automatic current scaling based on the load measurement via StallGuard2™ adapting the required current to the load. Energy consumption can be reduced by as much as 75%. CoolStep™ allows substantial energy savings, especially for motors which see varying loads or operate at a high duty cycle. Because a stepper motor application needs to work with a torque reserve of 30% to 50%, even a constant-load application allows significant energy savings because CoolStep™ automatically enables torque reserve when required. Reducing power consumption keeps the system cooler, increases motor life, and allows cost reduction.



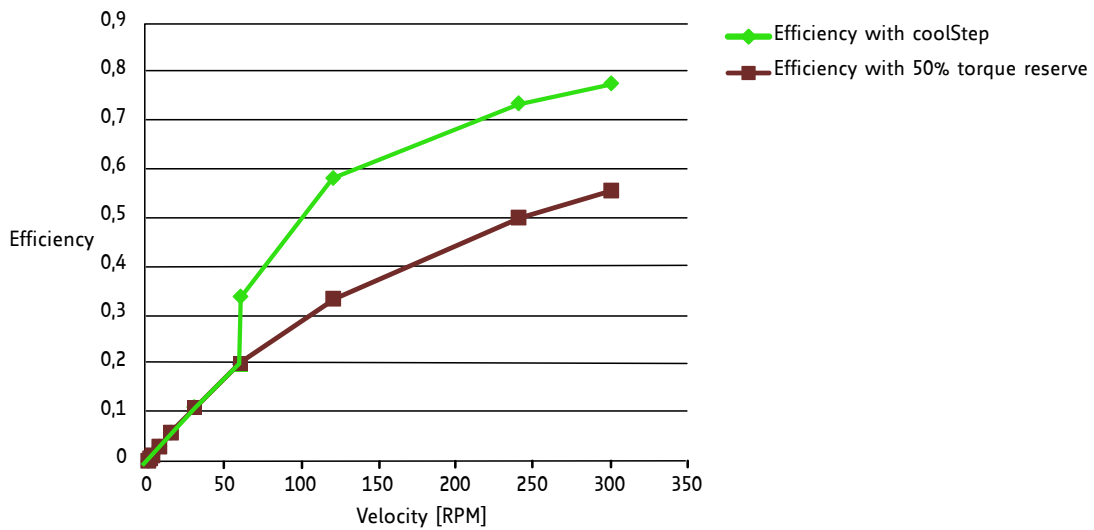

Figure 2: Energy Efficiency Example with CoolStep

1.5 SixPoint™ Motion Controller

TRINAMIC’s SixPoint™ motion controller is a new type of ramp generator which offers faster machine operation compared to the classical linear acceleration ramps. The SixPoint™ ramp generator allows adapting the acceleration ramps to the torque curves of a stepper motor. It uses two different acceleration settings for the acceleration phase and also two different deceleration settings for the deceleration phase. Start and stop speeds greater than zero can also be used.

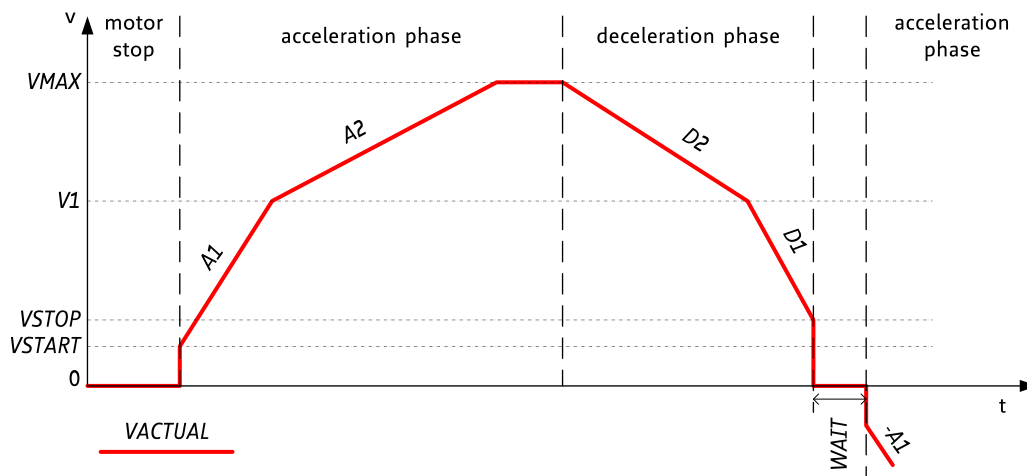

Figure 3: Typical motion profile with TRINAMIC’s SixPoint™ motion controller

A six point ramp begins using the start speed V_{START} (which can also be zero). Then, the acceleration value A_1 will be used to accelerate the motor to the speed V_1 . When the speed V_1 has been reached, the motor will be further accelerated using the acceleration value A_2 until it has reached the speed V_{MAX} . The deceleration phase begins using the deceleration value D_2 . After reaching the speed V_1 again the deceleration value D_1 will be used to decelerate to the stop speed V_{STOP} (which can also be zero).



The SixPoint™ ramp can be configured using the following objects:

Parameter Name	Object Index
Start velocity (V_{START})	2010 _h
Acceleration A1	2011 _h
Velocity V1	2012 _h
Acceleration A2	6083 _h
Maximum positioning velocity (V_{MAX})	6081 _h
Deceleration D2	6084 _h
Deceleration D1	2013 _h
Stop velocity V_{STOP}	6082 _h
Wait time WAIT	2015 _h

Table 2: SixPoint Ramp Parameters

Setting the velocity V1 (object 2012_h) to zero switches off the SixPoint™ ramp. In this case, a trapezoidal ramp defined by the parameters V_{START} , A2, V_{MAX} , D2 and V_{STOP} will be used.

Note

The SixPoint™ ramp will only be used in profile positioning mode (pp mode). Profile velocity mode (pv mode) will always use a trapezoidal ramp, defined just by the acceleration (object 6083_h), the speed given using object 60FF_h and the start and stop speed (objects 2010_h and 6082_h). The deceleration parameters will not be used in pv mode.



2 Communication

2.1 Reference Model

The application layer comprises a concept to configure and communicate real-time-data as well as the mechanisms for synchronization between devices. The functionality which the application layer offers to an application is logically divided over different service data objects (SDO) in the application layer. A service object offers a specific functionality and all the related services.

Applications interact by invoking services of a service object in the application layer. To realize these services this object exchanges data via the CAN Network with peer service object(s) using a protocol.

The application and the application layer interact with service primitives.

Service Primitives	
Primitive	Definition
Request	Issued by the application to the application layer to request a service.
Indication	Issued by the application layer to the application to report an internal event detected by the application layer or indicate that a service is requested.
Response	Issued by the application to the application layer to respond to a previous received indication.
Confirmation	Issued by the application layer to the application to report the result of a previously issued request.

Table 3: Service Primitives

A service type defines the primitives that are exchanged between the application layer and the cooperating applications for a particular service of a service object. Unconfirmed and confirmed services are collectively called remote services.



Service Types	
Type	Definition
Local service	Involves only the local service object. The application issues a request to its local service object that executes the requested service without communicating with peer service object(s).
Unconfirmed service	Involves one or more peer service objects. The application issues a request to its local service object. This request is transferred to the peer service object(s) that each passes it to their application as an indication. The result is not confirmed back.
Confirmed service	Can involve only one peer service object. The application issues a request to its local service object. This request is transferred to the peer service object that passes it to the other application as an indication. The other application issues a response that is transferred to the originating service object that passes it as a confirmation to the requesting application.
Provider initiated service	Involves only the local service object. The service object (being the service provider) detects an event not solicited by a requested service. This event is then indicated to the application.

Table 4: Service Types



2.2 NMT State Machine

The finite state machine (FSM) or simply state machine is a model of behavior composed of a finite number of states, transitions between those states, and actions. It shows which way the logic runs when certain conditions are met.

Starting and resetting the device is controlled via the state machine. The NMT state machine consists of the states shown in figure 4.

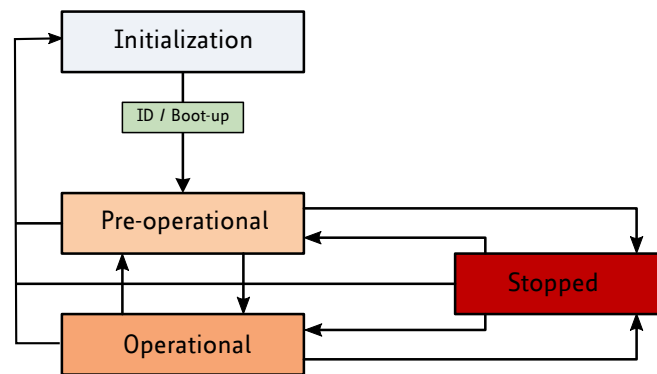

Figure 4: NMT State Machine

After power-on or reset the device enters the Initialization state. After the device initialization is finished, the device automatically transits to the **Pre-operational** state and indicates this state transition by sending the boot-up message. This way the device indicates that it is ready to work. A device that stays in Pre-operational state may start to transmit SYNC-, time stamp- or heartbeat message. In contrast to the PDO communication that is disabled in this state, the device can communicate via SDO.

The PDO communication is only possible within the **Operational** state. During Operational state the device can use all supported communication objects.

A device that was switched to the **Stopped** state only reacts on received NMT commands. In addition the device indicates the current NMT state by supporting the error control protocol during Stopped state.

The transitions between states are made by issuing a network management (NMT) communication object to the device. The NMT protocols are used to generate state machine change commands (e.g. to start and stop the device), detect remote device boot-ups and error conditions.

The Heartbeat message of a CANopen device contains the device status of the NMT state machine and is sent cyclically by the CANopen device.

The NMT state machine (or DS301 state machine) is not to be confused with the DS402 state machine. There is only one NMT state machine for the entire device, but for each motor there is a DS402 state machine which controls the motor. There are no links between these state machines, with one exception: When the NMT state machine is being switched to the stopped state, all DS402 state machines that are in OPERATION_ENABLED state will be switch to FAULT state.



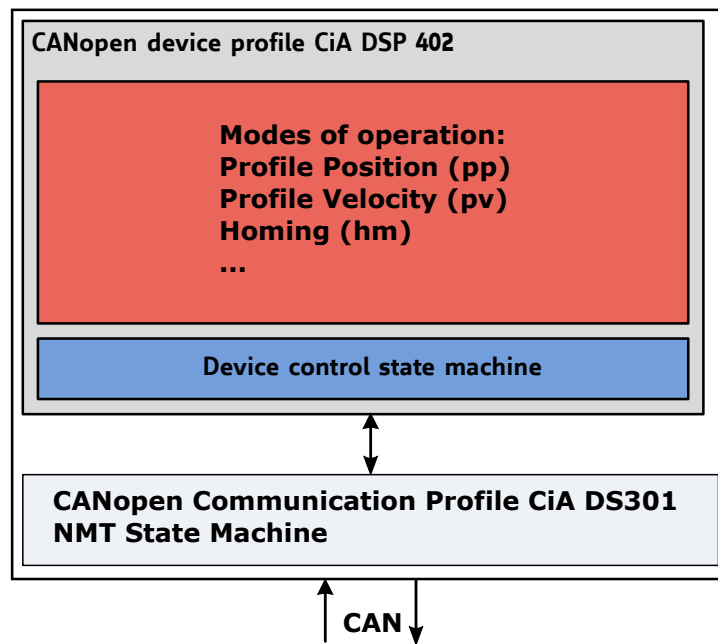

Figure 5: Communication Architecture

2.3 Device Model

A CANopen device mainly consists of the following parts:

- *Communication*: This function unit provides the communication objects and the appropriate functionality to transport data items via the underlying network structure.
- *Object dictionary*: The object dictionary is a collection of all the data items which have an influence on the behavior of the application objects, the communication objects and the state machine used on this device.
- *Application*: The application comprises the functionality of the device with respect to the interaction with the process environment.



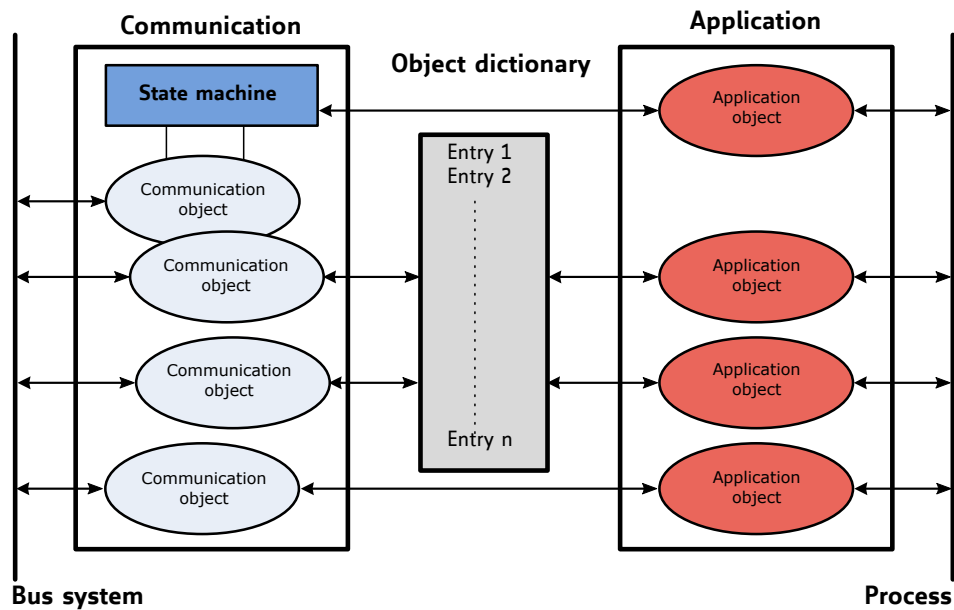

Figure 6: Device Model

2.4 Object Dictionary

The most important part of a device profile is the object dictionary description. The object dictionary is essentially a grouping of objects accessible via the network in an ordered pre-defined fashion. Each object within the dictionary is addressed using a 16-bit index. The overall layout of the standard object dictionary is shown in table 5:

Object Dictionary	
Index	Object
0000 _h	Not used.
0001 _h – 001F _h	Static data types.
0020 _h – 003F _h	Complex data types.
0040 _h – 005F _h	Manufacturer specific complex data types.
0060 _h – 007F _h	Device profile specific static data types.
0080 _h – 009F _h	Device profile specific complex data types.
00A0 _h – 0FFF _h	Reserved for further use.
1000 _h – 1FFF _h	Communication profile area.
2000 _h – 5FFF _h	Manufacturer specific profile area.
6000 _h – 9FFF _h	Standardized device profile area.
A000 _h – BFFF _h	Standardized interface profile area.
C000 _h – FFFF _h	Reserved for further use.

Table 5: Object Dictionary



The communication profile area at indices 1000_h through 1FFF_h contains the communication specific parameters for the CAN network. These entries are common to all devices.

The manufacturer segment at indices 2000_h through 5FFF_h contains manufacturer specific objects. These objects control the special features of the Trinamic TMCM-3212 motion control device.

The standardized device profile area at indices 6000_h through 9FFF_h contains all data objects common to a class of devices that can be read or written via the network. They describe the device parameters and the device functionality of the device profile.

2.4.1 Object Indices on Multi-Axis Modules

On a multi-axis module like the TMCM-3212 each object in the manufacturer area and each object in the profile specific area is available for each motor. In this manual, only the object indices for motor #0 are shown. The objects for the other motors can be accessed by adding offsets to the object indices:

- Add an offset of $motor_number \cdot 200_h$ to the index of a manufacturer specific object to get its index for other motors.
- Add an offset of $motor_number \cdot 800_h$ to the index of a profile specific object to get its index for other motors.

For example, the control word for motor #1 would be 6840_h (instead of 6040_h for motor #0), and the microstep resolution of motor #1 would be 2200_h for motor #1 (instead of 2000_h for motor #0).

Multi-Axis Object Indices		
Motor	Manufacturer area	Profile area
Motor #0	2000 _h – 21FF _h	6000 _h – 67FF _h
Motor #1	2200 _h – 23FF _h	6800 _h – 6FFF _h
Motor #2	2400 _h – 25FF _h	7000 _h – 77FF _h

Table 6: Multi-Axis Object Indices



3 Communication Area

The communication area contains all objects that define the communication parameters of the CANopen device according to the DS301 standard.

3.1 Detailed Object Specifications

3.1.1 Object 1000_h: Device Type

This object contains information about the device type. The object 1000_h describes the type of device and its functionality. It is composed of a 16-bit field which describes the device profile that is used and a second 16-bit field which provides additional information about optional functionality of the device.

Object Description			
Index	Name	Object Type	Data Type
1000 _h	Device type	Variable	UNSIGNED32

Table 7: Object Description (1000_h)

Entry Description				
Sub-index	Access	PDO Mapping	Value Range	Default Value
0	ro	no	UNSIGNED32	FFFC0192 _h

Table 8: Entry Description (1000_h)

3.1.2 Object 1001_h: Error Register

This object contains error information. The CANopen device maps internal errors into object 1001_h. It is part of an emergency object.

Object Description			
Index	Name	Object Type	Data Type
1001 _h	Error register	Variable	UNSIGNED8

Table 9: Object Description (1001_h)

Entry Description				
Sub-index	Access	PDO Mapping	Value Range	Default Value
0	ro	no	UNSIGNED8	0

Table 10: Entry Description (1001_h)



Error Register Bits	
Bit	Definition
0	Generic error
1	Current
2	Voltage
3	Temperature
4	Communication error
5	Device profile specific
6	Reserved (always 0)
7	Manufacturer specific

Table 11: Error Register Bits

3.1.3 Object 1005_h: COB-ID SYNC Message

This object defines the COB-ID of the synchronization object (SYNC). Further, it defines whether the module generates the SYNC.

Value Definition		
Bit	Name	Definition
30	Generate	0: Device does not generate SYNC message 1: Device generates SYNC message
29	Frame	Not supported, always set to 0.
28... 11	29 bit ID	Not supported, always set to 0.
10... 0	11 bit ID	11 bit COB-ID.

Table 12: Value Definition (1005_h)

Object Description			
Index	Name	Object Type	Data Type
1005 _h	COB-ID SYNC message	Variable	UNSIGNED32

Table 13: Object Description (1005_h)

Entry Description				
Sub-index	Access	PDO Mapping	Value Range	Default Value
0	rw	no	UNSIGNED32	80 _h

Table 14: Entry Description (1005_h)

3.1.4 Object 1008_h: Manufacturer Device Name

This object contains the name of the device as given by the manufacturer.

Object Description			
Index	Name	Object Type	Data Type
1008 _h	Manufacturer Device Name	Variable	Visible String

Table 15: Object Description (1008_h)

Entry Description				
Sub-index	Access	PDO Mapping	Value Range	Default Value
0	ro	no	—	TMCM-3212

Table 16: Entry Description (1008_h)

3.1.5 Object 1009_h: Manufacturer Hardware Version

This object contains the hardware version description.

Object Description			
Index	Name	Object Type	Data Type
1009 _h	Manufacturer Hardware Version	Variable	Visible String

Table 17: Object Description (1009_h)

Entry Description				
Sub-index	Access	PDO Mapping	Value Range	Default Value
0	ro	no	—	Depends on device, e.g. 1.0.

Table 18: Entry Description (1009_h)

3.1.6 Object 100A_h: Manufacturer Software Version

This object contains the software version description.

Object Description			
Index	Name	Object Type	Data Type
100A _h	Manufacturer Software Version	Variable	Visible String

Table 19: Object Description (100A_h)



Entry Description				
Sub-index	Access	PDO Mapping	Value Range	Default Value
0	ro	no	—	Depends on device, e.g. 1.0.

Table 20: Entry Description (100A_h)

3.1.7 Object 100C_h: Guard Time

The objects at index 100C_h and 100D_h shall indicate the configured guard time respectively the life time factor. The life time factor multiplied with the guard time gives the life time for the life guarding protocol.

Object Description			
Index	Name	Object Type	Data Type
100C _h	Guard Time	Variable	UNSIGNED16

Table 21: Object Description (100C_h)

Entry Description				
Sub-index	Access	PDO Mapping	Value Range	Default Value
0	rw	no	UNSIGNED16	0

Table 22: Entry Description (100C_h)

3.1.8 Object 100D_h: Life Time Factor

The life time factor multiplied with the guard time gives the life time for the life guarding protocol.

Object Description			
Index	Name	Object Type	Data Type
100D _h	Life Time Factor	Variable	UNSIGNED8

Table 23: Object Description (100D_h)

Entry Description				
Sub-index	Access	PDO Mapping	Value Range	Default Value
0	rw	no	UNSIGNED8	0

Table 24: Entry Description (100D_h)

3.1.9 Object 1010_h: Store Parameters

This object supports the saving of parameters in non volatile memory. By read access the device provides information about its saving capabilities.



There are several parameter groups:

- Sub-index 0_h: contains the largest sub-index that is supported.
- Sub-index 1_h: saves all parameters.
- Sub-index 2_h: saves communication parameters 2704_h and 2705_h.
- Sub-index 3_h: saves device profile parameters.
- Sub-index 4_h: saves motor 0 parameters.
- Sub-index 5_h: saves motor 1 parameters.
- Sub-index 6_h: saves motor 2 parameters.

Note In order to avoid storage of parameters by mistake, storage is only executed when a specific signature is written to the appropriate sub-Index. This signature is "save" (65766173_h, see also table 25).

Save Signature			
e	v	a	s
65 _h	76 _h	61 _h	73 _h

Table 25: Save Signature

On reception of the correct signature in the appropriate sub-index the device stores the parameter and then confirms the SDO transmission (initiate download response). If the storing failed, the device responds with an abort SDO transfer (abort code: 06060000_h). If a wrong signature is written, the device refuses to store and responds with abort SDO transfer (abort code: 0800002x_h).

On read access, each sub-index provides information if it is possible to store the parameter group. It reads 1 if yes and 0 if no.

Object Description			
Index	Name	Object Type	Data Type
1010 _h	Store Parameters	Array	UNSIGNED32

Table 26: Object Description (1010_h)



Entry Description					
Sub-index	Description	Access	PDO Mapping	Value Range	Default Value
01h	Save all parameters	rw	no	UNSIGNED32	—
02h	Save communication parameters	rw	no	UNSIGNED32	—
03h	Save device profile parameters	rw	no	UNSIGNED32	—
04h	Save motor axis 0 parameters	rw	no	UNSIGNED32	—
04h	Save motor axis 1 parameters	rw	no	UNSIGNED32	—
04h	Save motor axis 2 parameters	rw	no	UNSIGNED32	—

Table 27: Entry Description (1010_h)

3.1.10 Object 1011_h: Restore Parameters

With this object the default values of parameters according to the communication or device profile are restored. By read access the device provides information about its capabilities to restore these values.

There are several parameter groups:

- Sub-index 0_h: contains the largest sub-index that is supported.
- Sub-index 1_h: restores all parameters (factory reset).
- Sub-index 2_h: restores communication parameters 2704_h and 2705_h.
- Sub-index 3_h: restores device profile parameters.
- Sub-index 4_h: restores motor 0 parameters.
- Sub-index 5_h: restores motor 1 parameters.
- Sub-index 6_h: restores motor 2 parameters.

Note In order to avoid restoring the parameters by mistake, restoring is only executed when a specific signature is written to the appropriate sub-Index. This signature is "load" (64616F6C_h, see also table 28).

Load Signature			
d	a	o	l
64 _h	61 _h	6F _h	6C _h

Table 28: Load Signature

On reception of the correct signature in the appropriate sub-index the device restores the parameter and then confirms the SDO transmission (initiate download response). If the restoring failed, the device responds with an abort SDO transfer (abort code: 06060000_h). If a wrong signature is written, the device refuses to restore and responds with abort SDO transfer (abort code: 0800002x_h).



On read access, each sub-index provides information if it is possible to restore the parameter group. It reads 1 if yes and 0 if no.

After the default values have been restored they will become active after the next rest or power cycle of the TMCM-3212.

Object Description			
Index	Name	Object Type	Data Type
1011 _h	Restore parameters	Array	UNSIGNED32

Table 29: Object Description (1011_h)

Entry Description					
Sub-index	Description	Access	PDO Mapping	Value Range	Default Value
01h	Restore all parameters	rw	no	UNSIGNED32	—
02h	Restore communication parameters	rw	no	UNSIGNED32	—
03h	Restore device profile parameters	rw	no	UNSIGNED32	—
04h	Restore motor axis 0 parameters	rw	no	UNSIGNED32	—
04h	Restore motor axis 1 parameters	rw	no	UNSIGNED32	—
04h	Restore motor axis 2 parameters	rw	no	UNSIGNED32	—

Table 30: Entry Description (1011_h)

3.1.11 Object 1014_h: COB-ID Emergency Object

This object defines the COB-ID of the emergency object (EMCY).

Object Description			
Index	Name	Object Type	Data Type
1014 _h	COB-ID emergency object	Variable	UNSIGNED32

Table 31: Object Description (1014_h)

Entry Description				
Sub-index	Access	PDO Mapping	Value Range	Default Value
0	rw	no	UNSIGNED32	80 _h + Node ID

Table 32: Entry Description (1014_h)

3.1.12 Object 1015_h: Inhibit Time EMCY

The inhibit time for the EMCY message can be adjusted via this entry. The time has to be a multiple of 100µs.



Object Description			
Index	Name	Object Type	Data Type
1015 _h	COB-ID emergency object	Variable	UNSIGNED16

Table 33: Object Description (1015_h)

Entry Description				
Sub-index	Access	PDO Mapping	Value Range	Default Value
0	rw	no	UNSIGNED16	0

Table 34: Entry Description (1015_h)

3.1.13 Object 1016_h: Consumer Heartbeat Time

The consumer heartbeat time defines the expected heartbeat cycle time and thus has to be higher than the corresponding producer heartbeat time configured on the module producing this heartbeat. The monitoring starts after the reception of the first heartbeat. If the consumer heartbeat time is 0 the corresponding entry is not used. The time has to be a multiple of 1ms.

Value Definition		
Bits	Name	Definition
31...24	Reserved	—
23...16	Node ID	Heartbeat Producer Node ID
15...0	Heartbeat time	Time in 1ms

Table 35: Value Definition (1016_h)

Object Description			
Index	Name	Object Type	Data Type
1016 _h	Consumer heartbeat time	Variable	UNSIGNED16

Table 36: Object Description (1016_h)

Entry Description				
Sub-index	Access	PDO Mapping	Value Range	Default Value
0	rw	no	UNSIGNED16	0

Table 37: Entry Description (1016_h)

3.1.14 Object 1017_h: Producer Heartbeat Time

The producer heartbeat time defines the cycle time of the heartbeat. The producer heartbeat time is 0 if it is not used. The time has to be a multiple of 1ms.

Object Description			
Index	Name	Object Type	Data Type
1017 _h	Producer heartbeat time	Variable	UNSIGNED16

Table 38: Object Description (1017_h)

Entry Description				
Sub-index	Access	PDO Mapping	Value Range	Default Value
0	rw	no	UNSIGNED16	0

Table 39: Entry Description (1017_h)

3.1.15 Object 1018_h: Identity Object

The object 1018_h contains general information about the device:

- The vendor ID (sub-index 01_h) contains a unique value allocated to each manufacturer. The vendor ID of Trinamic is 286_h.
- The manufacturer specific product code (sub-index 2_h) identifies a specific device version.
- The manufacturer specific revision number (sub-index 3_h) consists of a major revision number and a minor revision number.

Object Description			
Index	Name	Object Type	Data Type
1018 _h	Identity object	Record	Identity

Table 40: Object Description (1018_h)

Entry Description					
Sub-index	Description	Access	PDO Mapping	Value Range	Default Value
00 _h	Number of entries	ro	no	0...3	3
01 _h	Vendor ID	ro	no	UNSIGNED32	0286 _h
02 _h	Product code	ro	no	UNSIGNED32	3212
03 _h	Revision number	ro	no	UNSIGNED32	e.g. 20003 _h for version 2.3

Table 41: Entry Description (1018_h)



3.1.16 Object 1023_h: OS Command

After switching to TMCL command mode using object 2700_h, this object can be used to send TMCL commands to the TMCM-3212 module. A TMCL command can be written to sub-index 1. After the command has been executed, the status code and the TMCL reply can be read from sub-index 2 and sub-index 3.

Object Description			
Index	Name	Object Type	Data Type
1023 _h	OS Command	Record	Command

Table 42: Object Description (1023_h)

Entry Description					
Sub-index	Description	Access	PDO Mapping	Value Range	Default Value
00 _h	Number of entries	ro	no	—	3
01 _h	TMCL command	rw	no	Octet string (7 bytes)	—
02 _h	Reply	ro	no	UNSIGNED8	—
03 _h	TMCL reply	ro	no	Octet string (7 bytes)	—

Table 43: Entry Description (1023_h)

3.1.17 Object 1029_h: Error Behaviour

If a device failure is detected in operational state, the device can be configured to enter alternatively the stopped state or remain in the current state in case of a device failure. Device failures include the following errors:

- Communication error
- Application error

Object Description			
Index	Name	Object Type	Data Type
1029 _h	Error behaviour	Array	UNSIGNED8

Table 44: Object Description (1029_h)

Entry Description					
Sub-index	Description	Access	PDO Mapping	Value Range	Default Value
00 _h	Number of error classes	ro	no	—	2
01 _h	Communication error	rw	no	UNSIGNED8	0 (enter stopped state)
02 _h	Application error	rw	no	UNSIGNED8	1 (remain in current state)

Table 45: Entry Description (1029_h)



3.1.18 Objects 1400_h – 1403_h: Receive PDO Communication Parameter

This object contains the communication parameters for the RPDOs which the device is able to receive. The sub-index 00_h contains the number of valid entries within the communication record. Its value normally is 2, as this object consists of two other entries.

Sub-index 01_h contains the COB-ID used by this PDO (in bits 10...0). Bit 30 (RTR bit) defines if this PDO uses RTRs. As RTRs are not supported for PDOs by this CANopen implementation, this bit must always be set in order to turn off RTR support for this PDO. Bit 31 defines if this PDO is active or not. If this bit is set, the PDO is inactive, and if this bit is clear, the PDO is active. Before making any changes to a PDO definition, set this bit to inactivate the PDO.

Sub-Index 02_h contains the transmission type of the RPDO. This can be FF_h or FE_h for event-driven, or 00_h for synchronous.

The RPDOs defined by objects 1400_h – 1403_h (RPDO 1...3) are normally used for motor #0. For the other motors, the following RPDOs are used:

- RPDO 65...68 (objects 1440_h – 1443_h) for motor #1.
- RPDO 129...132 (objects 1480_h – 1483_h) for motor #2.

Object Description			
Index	Name	Object Type	Data Type
1400 _h – 1403 _h	Receive PDO parameter	RECORD	RPDO CommPar
1400 _h	RPDO 1	RECORD	RPDO CommPar
1401 _h	RPDO 2	RECORD	RPDO CommPar
1402 _h	RPDO 3	RECORD	RPDO CommPar
1403 _h	RPDO 4	RECORD	RPDO CommPar

Table 46: Object Description (1400_h)

Entry Description				
Sub-index	Description	Access	Value Range	Default Value
00 _h	Largest sub-index supported	ro	2	2
01 _h	COB-ID used by PDO	rw	UNSIGNED32	Index 1400 _h : 200 _h + Node-ID Index 1401 _h : 300 _h + Node-ID Index 1402 _h : 400 _h + Node-ID Index 1403 _h : 500 _h + Node-ID
02 _h	Transmission type	rw	UNSIGNED8	Index 1400 _h : FF _h Index 1401 _h : FF _h Index 1402 _h : FF _h Index 1403 _h : FE _h

Table 47: Entry Description (1400_h)



3.1.19 Objects 1600_h – 1603_h: Receive PDO Mapping Parameter

These objects contain the mapping parameters for the RPDOs the device is able to receive. The sub-index 00_h contains the number of valid entries within the mapping record. This number of entries is also the number of the application variables which shall be received with the corresponding RPDO. The sub-indices from 01_h to the number of entries contain the information about the mapped application variables. These entries describe the PDO contents by their index, sub-index and length.

The RPDOs defined by objects 1600_h – 1603_h (RPDO 1...3) are normally used for motor #0. For the other motors, the following RPDOs are used:

- RPDO 65...68 (objects 1640_h – 1643_h) for motor #1.
- RPDO 129...132 (objects 1680_h – 1683_h) for motor #2.

Object Description			
Index	Name	Object Type	Data Type
1600 _h – 1603 _h	Receive PDO mapping parameter	RECORD	PDO Mapping
1600 _h	RPDO 1	RECORD	PDO Mapping
1601 _h	RPDO 2	RECORD	PDO Mapping
1602 _h	RPDO 3	RECORD	PDO Mapping
1603 _h	RPDO 4	RECORD	PDO Mapping

Table 48: Object Description (1600_h)

Entry Description				
Sub-index	Description	Access	Value Range	Default Value
00 _h	Number of mapped application objects in PDO	rw	0...3	Index 1600 _h : 1 Index 1601 _h : 2 Index 1602 _h : 2 Index 1603 _h : 2
01 _h	Mapping entry 1	rw	UNSIGNED32	Index 1600 _h : 60400010 _h Index 1601 _h : 60400010 _h Index 1602 _h : 60400010 _h Index 1603 _h : 60400010 _h
02 _h	Mapping entry 2	rw	UNSIGNED32	Index 1600 _h : 0 Index 1601 _h : 60600008 _h Index 1602 _h : 607A0020 _h Index 1603 _h : 60FF0020 _h
03 _h	Mapping entry 3	rw	UNSIGNED32	Index 1600 _h : 0 _h Index 1601 _h : 0 _h Index 1602 _h : 0 _h Index 1603 _h : 0 _h

Table 49: Entry Description (1600_h)



Before making changes to PDO definitions, first mark the PDO as inactive by setting bit 31 of its COB-ID (see section 3.1.18). Then, set its number of mapped PDO entries to zero (sub-index 0 of the appropriate PDO mapping object). Now, the mappings themselves can be changed. After that, set the number of map objects to the desired value, and finally activate the PDO by clearing bit 31 of its COB-ID.

3.1.20 Objects 1800_h – 1803_h: Transmit PDO Communication Parameter

This object contains the communication parameters for the TPDOs which the device is able to transmit. The sub-index 00_h contains the number of valid entries within the communication record. Its value normally is 5, as this object consists of five other entries.

Sub-index 01_h contains the COB-ID used by this PDO (in bits 10...0). Bit 30 (RTR bit) defines if this PDO uses RTRs. As RTRs are not supported for PDOs by this CANopen implementation, this bit must always be set in order to turn off RTR support for this PDO. Bit 31 defines if this PDO is active or not. If this bit is set, the PDO is inactive, and if this bit is clear, the PDO is active. Before making any changes to a PDO definition, set this bit to inactivate the PDO.

Sub-index 02_h contains the transmission type of the RPDO. This can be FF_h or FE_h for event-driven, or 00_h or 01_h for synchronous.

Sub-index 03_h contains the inhibit time, given in milliseconds. After a TPDO has been sent, it will not be sent again before the inhibit time has elapsed.

Sub-index 04_h is not used.

Sub-index 05_h contains the event timer value in milliseconds. When this is set to a value greater than 0 the TPDO will be sent repeatedly each time the event timer has elapsed. For example, when this value is set to 250, the TPDO will be sent every 250ms.

The TPDOs defined by objects 1800_h – 1803_h (TPDO 1...3) are normally used for motor #0. For the other motors, the following TPDOs are used:

- TPDO 65...68 (objects 1840_h – 1843_h) for motor #1.
- TPDO 129...132 (objects 1880_h – 1883_h) for motor #2.

Object Description			
Index	Name	Object Type	Data Type
1800 _h – 1803 _h	Transmit PDO communication parameter	RECORD	TPDO CommPar
1800 _h	TPDO 1	RECORD	TPDO CommPar
1801 _h	TPDO 2	RECORD	TPDO CommPar
1802 _h	TPDO 3	RECORD	TPDO CommPar
1803 _h	TPDO 4	RECORD	TPDO CommPar

Table 50: Object Description (1800_h)



Entry Description				
Sub-index	Description	Access	Value Range	Default Value
00 _h	Largest sub-index supported	ro	5	5
01 _h	COB-ID	rw	UNSIGNED32	Index 1800 _h : 180 _h + Node-ID Index 1801 _h : 280 _h + Node-ID Index 1802 _h : 380 _h + Node-ID Index 1803 _h : 480 _h + Node-ID
02 _h	Transmission type	rw	UNSIGNED8	Index 1800 _h : FF _h Index 1801 _h : FF _h Index 1802 _h : 01 _h Index 1803 _h : 01 _h
03 _h	Inhibit time	rw	UNSIGNED16	0
04 _h	Compatibility entry	ro	UNSIGNED8	0
05 _h	Event timer	rw	UNSIGNED16	0

Table 51: Entry Description (1800_h)

3.1.21 Objects 1A00_h – 1A03_h: Transmit PDO Mapping Parameter

These objects contain the mapping parameters for the TPDOs the device is able to transmit. The sub-index 00_h contains the number of valid entries within the mapping record. This number of entries is also the number of the application variables which shall be transmitted with the corresponding TPDO. The sub-indices from 01_h to the number of entries contain the information about the mapped application variables. These entries describe the PDO contents by their index, sub-index and length.

The TPDOs defined by objects 1A00_h – 1A03_h (TPDO 1...3) are normally used for motor #0. For the other motors, the following TPDOs are used:

- TPDO 65...68 (objects 1A40_h – 1A43_h) for motor #1.
- TPDO 129...132 (objects 1A80_h – 1A83_h) for motor #2.

Object Description			
Index	Name	Object Type	Data Type
1A00 _h – 1A03 _h	Transmit PDO mapping parameter	RECORD	PDO Mapping
1A00 _h	TPDO 1	RECORD	PDO Mapping
1A01 _h	TPDO 2	RECORD	PDO Mapping
1A02 _h	TPDO 3	RECORD	PDO Mapping
1A03 _h	TPDO 4	RECORD	PDO Mapping

Table 52: Object Description (1A00_h)

Entry Description				
Sub-index	Description	Access	Value Range	Default Value
00 _h	Number of mapped application objects in PDO	rw	0...3	Index 1A00 _h : 1 Index 1A01 _h : 2 Index 1A02 _h : 2 Index 1A03 _h : 2
01 _h	Mapping entry 1	rw	UNSIGNED32	Index 1A00 _h : 60410010 _h Index 1A01 _h : 60410010 _h Index 1A02 _h : 60410010 _h Index 1A03 _h : 60410010 _h
02 _h	Mapping entry 2	rw	UNSIGNED32	Index 1A00 _h : 0 Index 1A01 _h : 60610008 _h Index 1A02 _h : 60640020 _h Index 1A03 _h : 606C0020 _h
03 _h	Mapping entry 3	rw	UNSIGNED32	Index 1A00 _h : 0 _h Index 1A01 _h : 0 _h Index 1A02 _h : 0 _h Index 1A03 _h : 0 _h

Table 53: Entry Description (1A00_h)

Before making changes to PDO definitions, first mark the PDO as inactive by setting bit 31 of its COB-ID (see section 3.1.20). Then, set its number of mapped PDO entries to zero (sub-index 0 of the appropriate PDO mapping object). Now, the mappings themselves can be changed. After that, set the number of map objects to the desired value, and finally activate the PDO by clearing bit 31 of its COB-ID.



4 Manufacturer specific Area

The manufacturer segment contains manufacturer specific objects. These objects control the special features of the Trinamic Motion Control device TMCM-3212.

i Info

This section of the manual only shows the object indices for motor #0. Of course the same objects are also available for the other motors. For the other motors, add an offset of $motor_number \cdot 200_h$ to the object index. So for example the microstep resolution (object 2000_h for motor #0) can be accessed as object 2200_h for motor #1 and as object 2400_h for motor #2. Please see also section 2.4.1.

Multi-axis Object Indices	
Motor	Object Index Range
Motor #0	$2000_h - 21FF_h$
Motor #1	$2200_h - 23FF_h$
Motor #2	$2400_h - 25FF_h$

Table 54: Multi-axis Object Indices (Manufacturer specific Area)

4.1 Objects related to CoolStep™

Figure 7 shows an overview of the CoolStep™ related objects for motor #0. Please bear in mind that the figure only shows one example for a drive. There are objects which concern the configuration of the current. Other objects are for velocity regulation and for time adjustment. The CoolStep™ feature is sometimes also called SmartEnergy.

The following adjustments have to be made:

- Thresholds for current and velocity have to be identified and set.
- The StallGuard2™ feature has to be adjusted and enabled.
- The reduction or increasing of the current in the CoolStep™ area (depending on the load) has to be configured.



coolStep™ adjustment points and thresholds

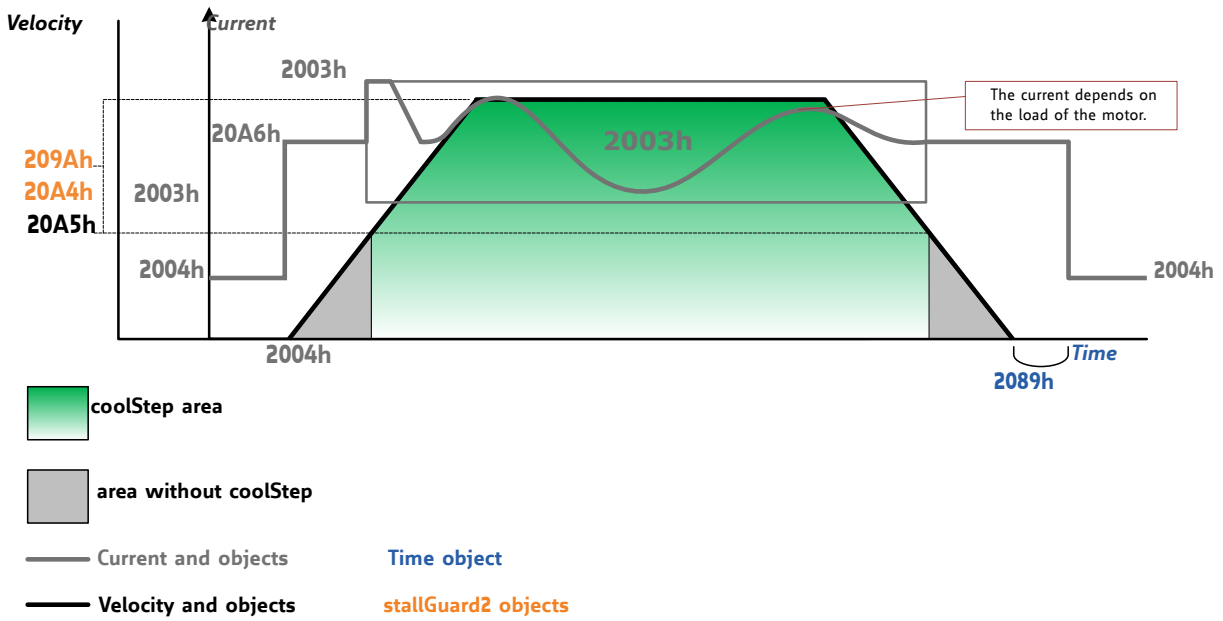

Figure 7: CoolStep Adjustment Points and Thresholds



CoolStep Adjustment Objects		
Object	Name	Description
2003 _h	Absolute maximum current	The maximum value is 255. This value means 100% of the maximum current of the module. The current adjustment is within the range 0...255 and can be adjusted in 32 steps (0...255 divided by eight; step 0 = 0...7, step 1 = 8...15 and so on). The most important motor setting, since too high values might cause motor damage!
2004 _h	Standby current	The current limit two seconds after the motor has stopped.
2098 _h	SmartEnergy current minimum	Sets the lower motor current limit for CoolStep operation by scaling the run current (object 2003 _h) value. This can be: 0: for 1/2 of the run current 1: for 1/4 of the run current
2099 _h	SmartEnergy current down step	Sets the speed of current decrement when the StallGuard2 reading is above the upper threshold. 0: slow decrement 3: fast decrement
209B _h	SmartEnergy current up step	Sets the current increment step when the StallGuard2 below the lower threshold. 0: slow increment 3: fast increment / fast reaction to rising load
209A _h	SmartEnergy hysteresis	Sets the distance between the lower and the upper threshold for StallGuard2 reading. Above the upper threshold the motor current becomes decreased.
20A4 _h	Stop on stall	Below this speed the motor will not be stopped. Above this speed the motor will stop in case StallGuard2 load value reaches zero.
20A5 _h	SmartEnergy threshold speed.	Above this speed CoolStep becomes enabled.
2089 _h	Standby delay	Standstill period before the current is changed down to standby current. The standard value is 200 which is 2 seconds.

Table 55: CoolStep related Objects



4.2 Detailed Object Specifications

4.2.1 Object 2000_h: Microstep Resolution

This object sets the microstep resolution of the drive. A value of 8 selects 256 (2^8) microsteps per full step.

Object Description			
Index	Name	Object Type	Data Type
2000 _h	Microstep Resolution	Variable	UNSIGNED8

Table 56: Object Description (2000_h)

Entry Description				
Sub-index	Access	PDO Mapping	Value Range	Default Value
0	rw	no	0...8	8

Table 57: Entry Description (2000_h)

4.2.2 Object 2001_h: Fullstep Resolution

This object sets the fullstep resolution of the motor connected to the drive. Its default value is 200 because most motors are 1.8° motors.

Object Description			
Index	Name	Object Type	Data Type
2001 _h	Motor full step resolution	Variable	UNSIGNED16

Table 58: Object Description (2001_h)

Entry Description				
Sub-index	Access	PDO Mapping	Value Range	Default Value
0	rw	no	0...65535	200

Table 59: Entry Description (2001_h)

4.2.3 Object 2002_h: Brake Delay Times

With this object the delay times for applying and releasing an (optional) brake can be defined. Please see also object 200Ah for an additional delay between enabling the power stage and releasing the brake. Both times are given in ms.



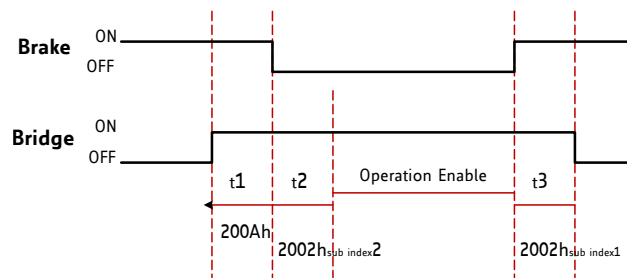

Figure 8: Brake Output Timing

Object Description			
Index	Name	Object Type	Data Type
2002 _h	Brake delay times	Array	UNSIGNED16

Table 60: Object Description (2002_h)

Entry Description					
Sub-index	Description	Access	PDO Mapping	Value Range	Default Value
1	Time between applying brake / disabling power stage	rw	no	0...65535	0
2	Time between releasing brake / switching the state machine to operational	rw	no	0..65535	0

Table 61: Entry Description (2002_h)

4.2.4 Object 2003_h: Maximum Current

This object defines the current used when the motor is moving. A value of 255 means 100% of the maximum current of the drive.

Object Description			
Index	Name	Object Type	Data Type
2003 _h	Maximum current	Variable	UNSIGNED8

Table 62: Object Description (2003_h)

Entry Description				
Sub-index	Access	PDO Mapping	Value Range	Default Value
0	rw	no	0...255	128

Table 63: Entry Description (2003_h)



4.2.5 Object 2004_h: Standby Current

This object defines the current used when the motor is standing (two seconds after the last move). A value of 255 means 100% of the maximum current of the drive.

Object Description			
Index	Name	Object Type	Data Type
2004 _h	Maximum current	Variable	UNSIGNED8

Table 64: Object Description (2004_h)

Entry Description				
Sub-index	Access	PDO Mapping	Value Range	Default Value
0	rw	no	0...255	8

Table 65: Entry Description (2004_h)

4.2.6 Object 2005_h: Limit Switches

This object defines which limit switches are to be used. Bit 0 stands for the left and bit 1 stands for the right limit switch. If a bit is set, the corresponding limit switch will not be used. So this object has to be set to the value 3 if limit switches are not connected. The object can only be written when the drive is in the SWITCHED_ON_DISABLED state (but is always readable).

The limit switches can also be inverted using bit 2 and bit 3:

- Bit 2 inverts the left limit switch
- Bit 3 inverts the right limit switch

The polarity of the home switch can be set using bit 5.

Object Description			
Index	Name	Object Type	Data Type
2005 _h	Limit switches	Variable	UNSIGNED32

Table 66: Object Description (2005_h)

Entry Description				
Sub-index	Access	PDO Mapping	Value Range	Default Value
0	rw	no	0...63	0

Table 67: Entry Description (2005_h)



Bit Definitions	
Bit	Definition
0	Left limit switch deactivated if set.
1	Right limit switch deactivated if set.
2	Left limit switch inverted if set.
3	Right limit switch inverted if set.
4	Home switch deactivated if set.
5	Home switch inverted if set.

Table 68: Bit Definitions (2005_h)

4.2.7 Object 200A_h: Enable Drive Delay Time

This is an additional delay time (in milliseconds) between enabling the power stage and releasing the brake. It can be used to prevent the brake from being released too early (before the hold current in the motor has been reached). Please see also object 4.2.3.

Object Description			
Index	Name	Object Type	Data Type
200A _h	Enable drive delay time	Variable	UNSIGNED16

Table 69: Object Description (200A_h)

Entry Description				
Sub-index	Access	PDO Mapping	Value Range	Default Value
0	rw	no	0...65535	0

Table 70: Entry Description (200A_h)

4.2.8 Object 200B_h: Encoder Parameters

This object defines encoder parameters. These are the polarity of the encoder null channel, the direction of rotation (set it to 1 if the direction is reversed compared to the motor) and if the position is to be initialized with the encoder position. It is only writable in SWITCHED_ON_DISABLED state.

Object Description			
Index	Name	Object Type	Data Type
200B _h	Encoder parameters	Array	UNSIGNED8

Table 71: Object Description (200B_h)

Entry Description					
Sub-index	Description	Access	PDO Mapping	Value Range	Default Value
1	Null channel polarity	rw	no	0/1	0
2	Direction of rotation	rw	no	0/1	0
3	Initialize position	rw	no	0/1	1

Table 72: Entry Description (200B_h)

4.2.9 Object 200C_h: Brake Current Feed

This object configures how much current has to be fed into the brake to apply and to release it. 0 means 0%, 255 means 100% of the maximum current (this depends on the module). In most cases it is needed to feed current into the brake to release it. Setting both values to 0 disables the automatic brake control. This object is only writable in SWITCHED_ON_DISABLED state.

Object Description			
Index	Name	Object Type	Data Type
200C _h	Brake current feed	Array	UNSIGNED8

Table 73: Object Description (200C_h)

Entry Description					
Sub-index	Description	Access	PDO Mapping	Value Range	Default Value
1	Apply current	rw	no	0...255	0
2	Release current	rw	no	0...255	0

Table 74: Entry Description (200C_h)

4.2.10 Object 200F_h: Encoder N Channel Latch

With this object it is possible to make use of the encoder N channel latch capabilities of the motion controller used on the TMCM-3212 module. Write 1 to sub-index 1 to activate the latch functionality. When the encoder N channel has been passed, the internal position and the encoder position will automatically be stored to sub-index 2 and sub-index 3 of this object, and sub-index 1 will be reset to zero to show that the N channel event has occurred.

The encoder interface must have been configured properly in order to make this function work correctly.

Object Description			
Index	Name	Object Type	Data Type
200F _h	Encoder N Channel Latch	Variable	RECORD

Table 75: Object Description (200F_h)



Entry Description					
Sub-index	Description	Access	PDO Mapping	Value Range	Default Value
1	Mode	rw	no	0/1	0
2	Latched internal position	ro	no	SIGNED32	0
3	Latched encoder position	ro	no	SIGNED32	0

Table 76: Entry Description (200F_h)

4.2.11 Object 2010_h: Profile Start Velocity

This object contains the velocity with which a positioning ramp will be started.

Object Description			
Index	Name	Object Type	Data Type
2010 _h	Profile Start Velocity	Variable	UNSIGNED32

Table 77: Object Description (2010_h)

Entry Description				
Sub-index	Access	PDO Mapping	Value Range	Default Value
0	rw	no	0...268435455	0

Table 78: Entry Description (2010_h)

4.2.12 Object 2011_h: Profile A1

This object contains the acceleration value used for ramping up from the start velocity (object 2011_h, see section 4.2.11) to the velocity V1 (object (2012)_h, see section 4.2.13).

Object Description			
Index	Name	Object Type	Data Type
2011 _h	Profile A1	Variable	UNSIGNED32

Table 79: Object Description (2011_h)

Entry Description				
Sub-index	Access	PDO Mapping	Value Range	Default Value
0	rw	no	0...16777215	0

Table 80: Entry Description (2011_h)

4.2.13 Object 2012_h: Profile V1

This object contains the velocity used for the first segment of a positioning ramp.

Object Description			
Index	Name	Object Type	Data Type
2012 _h	Profile V1	Variable	UNSIGNED32

Table 81: Object Description (2012_h)

Entry Description				
Sub-index	Access	PDO Mapping	Value Range	Default Value
0	rw	no	0...16777215	0

Table 82: Entry Description (2012_h)

4.2.14 Object 2013_h: Profile D1

This object contains the deceleration value used for decelerating from the maximum positioning velocity to the velocity V1 (object 2012_h, see section 4.2.13).

Object Description			
Index	Name	Object Type	Data Type
2013 _h	Profile D1	Variable	UNSIGNED32

Table 83: Object Description (2013_h)

Entry Description				
Sub-index	Access	PDO Mapping	Value Range	Default Value
0	rw	no	0...16777215	0

Table 84: Entry Description (2013_h)

4.2.15 Object 2015_h: Ramp Wait Time

This object defines the waiting time after ramping down to zero velocity before the next movement or direction inversion can start. Time range is 0 to 2 seconds. This setting avoids excess acceleration e.g. from positive stop velocity to negative start velocity.



Object Description			
Index	Name	Object Type	Data Type
2015 _h	Ramp Wait Time	Variable	UNSIGNED16

Table 85: Object Description (2015_h)

Entry Description				
Sub-index	Access	PDO Mapping	Value Range	Default Value
0	rw	no	0...65535 [0.000032s]	0

Table 86: Entry Description (2015_h)

4.2.16 Object 2089_h: Setting Delay

This object has to be used for setting a standstill period before the current is changed down to standby current.

Unit: 10msec

Object Description			
Index	Name	Object Type	Data Type
2089 _h	Setting Delay	Variable	UNSIGNED16

Table 87: Object Description (2089_h)

Entry Description				
Sub-index	Access	PDO Mapping	Value Range	Default Value
0	rw	no	0...400	0

Table 88: Entry Description (2089_h)

4.2.17 Object 208C_h: Velocity Dimension Index

With this object different units can be chosen:

- Writing 0 selects internal units.
- Writing 181 sets PPS for velocity and PPS/s for acceleration.

This can only be changed in SWITCHED_ON_DISABLED mode.



Object Description			
Index	Name	Object Type	Data Type
208C _h	Velocity Dimension Index	Variable	UNSIGNED8

Table 89: Object Description (208C_h)

Entry Description				
Sub-index	Access	PDO Mapping	Value Range	Default Value
0	rw	no	0/181	181

Table 90: Entry Description (208C_h)

4.2.18 Object 208E_h: Acceleration Dimension Index

With this object, the unit for acceleration can be read out. The unit can be set using object 208C_h. Object 208E_h reads 0 when internal units are selected and 179 when PPS/s is selected.

Object Description			
Index	Name	Object Type	Data Type
208E _h	Acceleration Dimension Index	Variable	UNSIGNED8

Table 91: Object Description (208E_h)

Entry Description				
Sub-index	Access	PDO Mapping	Value Range	Default Value
0	ro	no	0/179	179

Table 92: Entry Description (208E_h)

4.2.19 Object 2092_h: Chopper Blank Time

This object serves for selecting the comparator blank time. This time needs to safely cover the switching event and the duration of the ringing on the sense resistor. For low current drivers, a setting of 1 or 2 is good. For higher current applications a setting of 2 or 3 will be required.

Object Description			
Index	Name	Object Type	Data Type
2092 _h	Chopper Blank Time	Variable	UNSIGNED8

Table 93: Object Description (2092_h)

Entry Description				
Sub-index	Access	PDO Mapping	Value Range	Default Value
0	rw	no	0...3	2

Table 94: Entry Description (2092_h)

4.2.20 Object 2093_h: Chopper Mode

Select the chopper mode using this object:

- 0 – spreadCycle chopper
- 1 – classic constant off time chopper

Object Description			
Index	Name	Object Type	Data Type
2093 _h	Chopper Mode	Variable	UNSIGNED8

Table 95: Object Description (2093_h)

Entry Description				
Sub-index	Access	PDO Mapping	Value Range	Default Value
0	rw	no	0/1	0

Table 96: Entry Description (2093_h)

4.2.21 Object 2094_h: Chopper Hysteresis Decrement

This object serves for the hysteresis decrement setting. This setting determines the slope of the hysteresis during on time and during fast decay time.

- 0 – fast decrement
- 3 – very slow decrement

Object Description			
Index	Name	Object Type	Data Type
2094 _h	Chopper Hysteresis Decrement	Variable	UNSIGNED8

Table 97: Object Description (2094_h)

Entry Description				
Sub-index	Access	PDO Mapping	Value Range	Default Value
0	rw	no	0...3	0

Table 98: Entry Description (2094_h)

4.2.22 Object 2095_h: Chopper Hysteresis End

This object provides the setting of the hysteresis end value after a number of decrements. The decrement interval time is controlled by object 2094_h (section 4.2.21).

Possible values are:

- -3...-1 – negative hysteresis end setting
- 0 – zero hysteresis end setting
- 1...12 – positive hysteresis end setting

Object Description			
Index	Name	Object Type	Data Type
2095 _h	Chopper Hysteresis End	Variable	SIGNED8

Table 99: Object Description (2095_h)

Entry Description				
Sub-index	Access	PDO Mapping	Value Range	Default Value
0	rw	no	-3...12	0

Table 100: Entry Description (2095_h)

4.2.23 Object 2096_h: Chopper Hysteresis Start

This object provides the hysteresis start setting. Please notice that this value is an offset to the hysteresis end value.

Object Description			
Index	Name	Object Type	Data Type
2096 _h	Chopper Hysteresis Start	Variable	UNSIGNED8

Table 101: Object Description (2096_h)

Entry Description				
Sub-index	Access	PDO Mapping	Value Range	Default Value
0	rw	no	0...8	3

Table 102: Entry Description (2096_h)

4.2.24 Object 2097_h: Chopper Off Time

The off time setting controls the minimum chopper frequency. Under normal circumstances, an off time within the range of 5µs to 20µs is used. Off time setting for constant t_{OFF} chopper: $N_{CLK} = 12 + 32 * t_{OFF}$.



Minimum is 64 clocks.

Setting this parameter to zero completely disables all driver transistors and so lets the motor free-wheel.

Object Description			
Index	Name	Object Type	Data Type
2097 _h	Chopper Off Time	Variable	UNSIGNED8

Table 103: Object Description (2097_h)

Entry Description				
Sub-index	Access	PDO Mapping	Value Range	Default Value
0	rw	no	0 / 2...15	5

Table 104: Entry Description (2097_h)

4.2.25 Object 2098_h: Smart Energy Current Minimum

This object provides the setting of the lower motor current limit for CoolStep™ operation by scaling the CS value.

Possible values are:

- 0 – 1/2 of maximum motor current setting (section 4.2.4)
- 1 – 1/4 of maximum motor current setting (section 4.2.4)

Object Description			
Index	Name	Object Type	Data Type
2098 _h	Smart Energy Current Minimum	Variable	UNSIGNED8

Table 105: Object Description (2098_h)

Entry Description				
Sub-index	Access	PDO Mapping	Value Range	Default Value
0	rw	no	0/1	0

Table 106: Entry Description (2098_h)

4.2.26 Object 2099_h: Smart Energy Current Down Step

This object provides the setting of the number of StallGuard2 readings above the upper threshold necessary for each current decrement of the motor current.

Possible values are:

- 0 – 32 measurements – slowest decrement
- 1 – 8 measurements



- 2 – 2 measurements
- 3 – 1 measurements – fastest decrement

Object Description			
Index	Name	Object Type	Data Type
2099 _h	Smart Energy Current Down Step	Variable	UNSIGNED8

Table 107: Object Description (2099_h)

Entry Description				
Sub-index	Access	PDO Mapping	Value Range	Default Value
0	rw	no	0...3	0

Table 108: Entry Description (2099_h)

4.2.27 Object 209A_h: Smart Energy Hysteresis

This object sets the distance between the lower and the upper threshold for StallGuard2 reading. Above the upper threshold the motor current becomes decreased.

Hysteresis: (SmartEnergy hysteresis value + 1) * 32

Upper StallGuard2 threshold: (SmartEnergy hysteresis start + SmartEnergy hysteresis + 1) * 32

Object Description			
Index	Name	Object Type	Data Type
209A _h	Smart Energy Hysteresis	Variable	UNSIGNED8

Table 109: Object Description (209A_h)

Entry Description				
Sub-index	Access	PDO Mapping	Value Range	Default Value
0	rw	no	0...15	0

Table 110: Entry Description (209A_h)

4.2.28 Object 209B_h: Smart Energy Current Up Step

This object sets the current increment step. The current becomes incremented for each measured StallGuard2 value below the lower threshold (see smart energy hysteresis start (object 209C_h, section 4.2.29).

Possible values are:

- 0 – 1 step – slowest increment



- 1 – 2 steps
- 2 – 4 steps
- 3 – 8 steps – fastest increment

Object Description			
Index	Name	Object Type	Data Type
209B _h	Smart Energy Current Up Step	Variable	UNSIGNED8

Table 111: Object Description (209B_h)

Entry Description				
Sub-index	Access	PDO Mapping	Value Range	Default Value
0	rw	no	0...3	0

Table 112: Entry Description (209B_h)

4.2.29 Object 209C_h: Smart Energy Hysteresis Start

This object serves to set the lower threshold for the StallGuard2 value (see smart Energy current up step (section 4.2.28)). Setting this to 0 disables the CoolStep™ function.

Object Description			
Index	Name	Object Type	Data Type
209C _h	Smart Energy Hysteresis Start	Variable	UNSIGNED8

Table 113: Object Description (209C_h)

Entry Description				
Sub-index	Access	PDO Mapping	Value Range	Default Value
0	rw	no	0...15	0

Table 114: Entry Description (209C_h)

4.2.30 Object 209D_h: Smart Energy Filter Enable

This object is used to set the StallGuard2 filter for more precision of the measurement. It reduces the measurement frequency to one measurement per four fullsteps if set.

In most cases it is expedient to set the filtered mode when using CoolStep™. Use the standard mode for step loss detection.

Possible values are:

- 0 – standard mode
- 1 – filtered mode



Object Description			
Index	Name	Object Type	Data Type
209D _h	Smart Energy Filter Enable	Variable	UNSIGNED8

Table 115: Object Description (209D_h)

Entry Description				
Sub-index	Access	PDO Mapping	Value Range	Default Value
0	rw	no	0/1	0

Table 116: Entry Description (209D_h)

4.2.31 Object 209E_h: StallGuard2 Threshold

This signed value controls the StallGuard2 threshold level for stall output and sets the optimum measurement range for readout. A lower value gives a higher sensitivity. Zero is the starting value. A higher value makes StallGuard2 less sensitive and requires more torque to indicate a stall.

Object Description			
Index	Name	Object Type	Data Type
209E _h	StallGuard2 Threshold	Variable	SIGNED8

Table 117: Object Description (209E_h)

Entry Description				
Sub-index	Access	PDO Mapping	Value Range	Default Value
0	rw	no	-63...63	0

Table 118: Entry Description (209E_h)

4.2.32 Object 20A1_h: Short Protection Disable

This object is used to enable or to disable the short to ground protection. Normally there is no need to change this. Use the default value.

Possible values are:

- 0 – Short to GND protection enabled
- 1 – Short to GND protection disabled

Object Description			
Index	Name	Object Type	Data Type
20A1 _h	Short Protection Disable	Variable	UNSIGNED8

Table 119: Object Description (20A1_h)



Entry Description				
Sub-index	Access	PDO Mapping	Value Range	Default Value
0	rw	no	0/1	0

Table 120: Entry Description (20A1_h)

4.2.33 Object 20A3_h: Vsense

This object is used for setting the sense resistor voltage based current scaling. *Use the default value and change only when recommended by Trinamic.*

Possible settings are:

- 0 - Full scale sense resistor voltage is 1/18 VDD
- 1 - Full scale sense resistor voltage is 1/36 VDD

Object Description			
Index	Name	Object Type	Data Type
20A3 _h	Vsense	Variable	UNSIGNED8

Table 121: Object Description (20A3_h)

Entry Description				
Sub-index	Access	PDO Mapping	Value Range	Default Value
0	rw	no	0/1	0

Table 122: Entry Description (20A3_h)

4.2.34 Object 20A4_h: Stop on Stall

Below this speed the motor will not be stopped. Above this speed the motor will be stopped in case the StallGuard2 load value reaches zero.

Object Description			
Index	Name	Object Type	Data Type
20A4 _h	Stop on Stall	Variable	UNSIGNED32

Table 123: Object Description (20A4_h)

Entry Description				
Sub-index	Access	PDO Mapping	Value Range	Default Value
0	rw	no	0...2147483647	0

Table 124: Entry Description (20A4_h)

4.2.35 Object 20A5_n: Smart Energy Threshold Speed

The CoolStep™ functionality will be enabled when the actual speed is above this speed. It will be disabled again when the actual speed drops below this value.

Object Description			
Index	Name	Object Type	Data Type
20A5 _n	Smart Energy Threshold Speed	Variable	UNSIGNED32

Table 125: Object Description (20A5_n)

Entry Description				
Sub-index	Access	PDO Mapping	Value Range	Default Value
0	rw	no	0...2147483647	0

Table 126: Entry Description (20A5_n)

4.2.36 Object 20B0_n: PWM Threshold Speed

The StealthChop feature will be switched on when the value of this object is greater than zero and the actual velocity is lower than the value set by this object.

Object Description			
Index	Name	Object Type	Data Type
20B0 _n	PWM Threshold Speed	Variable	UNSIGNED32

Table 127: Object Description (20B0_n)

Entry Description				
Sub-index	Access	PDO Mapping	Value Range	Default Value
0	rw	no	0...16777215	0

Table 128: Entry Description (20B0_n)

4.2.37 Object 20B1_n: PWM Gradient

Velocity dependent gradient for the PWM amplitude (StealthChop). Setting this value to 0 turns off StealthChop.



Object Description			
Index	Name	Object Type	Data Type
20B1 _h	PWM Gradient	Variable	UNSIGNED8

Table 129: Object Description (20B1_h)

Entry Description				
Sub-index	Access	PDO Mapping	Value Range	Default Value
0	rw	no	0...255	0

Table 130: Entry Description (20B1_h)

4.2.38 Object 20B2_h: PWM Amplitude

Maximum PWM amplitude when switching to StealthChop mode. Do not set too low. Values above 64 are recommended.

Object Description			
Index	Name	Object Type	Data Type
20B2 _h	PWM Amplitude	Variable	UNSIGNED8

Table 131: Object Description (20B2_h)

Entry Description				
Sub-index	Access	PDO Mapping	Value Range	Default Value
0	rw	no	0...255	0

Table 132: Entry Description (20B2_h)

4.2.39 Object 20B3_h: DcStep Minimum Speed

Minimum speed for switching to DcStep. The motor driver will not switch to DcStep mode when the actual velocity is below this value. Setting this object to zero completely switches off DcStep.

Object Description			
Index	Name	Object Type	Data Type
20B3 _h	DcStep Minimum Speed	Variable	UNSIGNED32

Table 133: Object Description (20B3_h)

Entry Description				
Sub-index	Access	PDO Mapping	Value Range	Default Value
0	rw	no	0...16777215	0

Table 134: Entry Description (20B3_h)

4.2.40 Object 20B4_h: DcStep Time

This setting controls the reference pulse width for DcStep load measurement. It must be optimized for robust operation with maximum motor torque. A higher value allows higher torque and higher velocity, a lower value allows operation down to a lower velocity as set by the minimum DcStep speed (object 20B3_h, see section 4.2.39).

Object Description			
Index	Name	Object Type	Data Type
20B4 _h	DcStep Time	Variable	UNSIGNED16

Table 135: Object Description (20B4_h)

Entry Description				
Sub-index	Access	PDO Mapping	Value Range	Default Value
0	rw	no	0...1023	0

Table 136: Entry Description (20B4_h)

4.2.41 Object 20B5_h: DcStep StallGuard

This setting controls stall detection in DcStep mode. Increase this value for higher sensitivity.

Object Description			
Index	Name	Object Type	Data Type
20B5 _h	DcStep StallGuard	Variable	UNSIGNED8

Table 137: Object Description (20B5_h)

Entry Description				
Sub-index	Access	PDO Mapping	Value Range	Default Value
0	rw	no	0...255	0

Table 138: Entry Description (20B5_h)

4.2.42 Object 20B6_h: Fullstep Threshold Speed

Depending on the settings of objects 20B7_h and 20B8_h (see sections 4.2.43 and 4.2.44) the driver switches to fullstep mode and/or to a different chopper mode when the speed set by this object is exceeded.

Object Description			
Index	Name	Object Type	Data Type
20B6 _h	Fullstep Threshold Speed	Variable	UNSIGNED32

Table 139: Object Description (20B6_h)

Entry Description				
Sub-index	Access	PDO Mapping	Value Range	Default Value
0	rw	no	0...16777215	0

Table 140: Entry Description (20B6_h)

4.2.43 Object 20B7_h: High Speed Chopper Mode

The motor driver will switch to a different chopper mode when this object is set to 1 and the measured speed is greater than the threshold speed set by object 20B6_h (see section 4.2.42).

Object Description			
Index	Name	Object Type	Data Type
20B7 _h	High Speed Chopper Mode	Variable	UNSIGNED8

Table 141: Object Description (20B7_h)

Entry Description				
Sub-index	Access	PDO Mapping	Value Range	Default Value
0	rw	no	0/1	0

Table 142: Entry Description (20B7_h)

4.2.44 Object 20B8_h: High Speed Fullstep Mode

The motor driver will switch to fullstep mode when this object is set to 1 and the measured speed is greater than the threshold speed set by object 20B6_h (see section 4.2.42).

Object Description			
Index	Name	Object Type	Data Type
20B8 _h	High Speed Chopper Mode	Variable	UNSIGNED8

Table 143: Object Description (20B8_h)



Entry Description				
Sub-index	Access	PDO Mapping	Value Range	Default Value
0	rw	no	0/1	0

Table 144: Entry Description (20B8_h)

4.2.45 Object 20B9_h: Power Down Ramp

The value set by this object controls the number of clock cycles for motor power down after a motion as soon as the motor has stopped and the setting time (set by object 2089_h, please see section 4.2.16) has expired. The smooth transition avoids a motor jerk upon power down.

- 0=instant power down.
- 15=longest possible power down ramp.

Object Description			
Index	Name	Object Type	Data Type
20B9 _h	Power Down Ramp	Variable	UNSIGNED8

Table 145: Object Description (20B9_h)

Entry Description				
Sub-index	Access	PDO Mapping	Value Range	Default Value
0	rw	no	0 ... 15	7

Table 146: Entry Description (20B9_h)

4.2.46 Object 2100_h: Home Offset Display

This object shows the home offset. The value is given in microsteps.

Object Description			
Index	Name	Object Type	Data Type
2100 _h	Home Offset Display	Variable	SIGNED32

Table 147: Object Description (2100_h)

Entry Description				
Sub-index	Access	PDO Mapping	Value Range	Default Value
0	ro	no	-2147483648...2147483647	0

Table 148: Entry Description (2100_h)

4.2.47 Object 2101_h: Actual Load Value

This object shows the actual load value used for stall detection (StallGuard2™).

Object Description			
Index	Name	Object Type	Data Type
2101 _h	Actual Load Value	Variable	UNSIGNED16

Table 149: Object Description (2101_h)

Entry Description				
Sub-index	Access	PDO Mapping	Value Range	Default Value
0	ro	no	0...1023	0

Table 150: Entry Description (2101_h)

4.2.48 Object 2102_h: Driver Error Flags

This object shows the error flags of the motor driver IC.

Error Flags		
Bit	Name	Meaning
7	OT	Overtemperature
6	OTPW	Temperature pre-warning
5	UV	Undervoltage
4	OCHS	Overcurrent high side
3	OLB	Open load on bridge B
2	OLA	Open load on bridge A
1	OCB	Overcurrent on bridge B
0	OCA	Overcurrent on bridge A

Table 151: Driver Error Flags (2102_h)

Object Description			
Index	Name	Object Type	Data Type
2102 _h	Driver Error Flags	Variable	UNSIGNED8

Table 152: Object Description (2102_h)



Entry Description				
Sub-index	Access	PDO Mapping	Value Range	Default Value
0	ro	no	0...255	0

Table 153: Entry Description (2102_h)

4.2.49 Object 2107_h: Microstep Resolution Display

This object shows the microstep resolution, set by object 2000_h (please see section 4.2.1).

Object Description			
Index	Name	Object Type	Data Type
2107 _h	Microstep resolution display	Variable	UNSIGNED8

Table 154: Object Description (2107_h)

Entry Description				
Sub-index	Access	PDO Mapping	Value Range	Default Value
0	ro	no	0...8	8

Table 155: Entry Description (2107_h)

4.2.50 Object 210B_h: Step Counter

This object shows the overall number of microsteps done by this motor so far. The value can be read as a 64 bit value (sub-index 3) or split into two 32 bit values (sub-index 1 and sub-index 2).

Object Description			
Index	Name	Object Type	Data Type
210B _h	Step Counter	Variable	RECORD

Table 156: Object Description (210B_h)

Entry Description					
Sub-index	Description	Access	PDO Mapping	Value Range	Default Value
1	Lower 32 Bits	ro	no	0...ffffffff _h	0
2	Higher 32 Bits	ro	no	0...ffffffff _h	0
3	64 Bit Value	ro	no	0...ffffffffffffffff _h	0

Table 157: Entry Description (210B_h)



4.2.51 Object 2121_h: PWM Scale Value

Actual PWM scale value used when the motor driver is operating in StealthChop mode.

Object Description			
Index	Name	Object Type	Data Type
2121 _h	PWM Scale Value	Variable	UNSIGNED8

Table 158: Object Description (2121_h)

Entry Description				
Sub-index	Access	PDO Mapping	Value Range	Default Value
0	ro	no	0...255	—

Table 159: Entry Description (2121_h)

4.2.52 Object 2122_h: Measured Velocity

This object contains the velocity measured by the motor driver. This value is important only when the motor driver is operating in DcStep mode.

Object Description			
Index	Name	Object Type	Data Type
2122 _h	Measured Velocity	Variable	SIGNED32

Table 160: Object Description (2122_h)

Entry Description				
Sub-index	Access	PDO Mapping	Value Range	Default Value
0	ro	no	-16777215...16777215	—

Table 161: Entry Description (2122_h)

4.2.53 Object 2700_h: TMCL Direct Communication

After writing the make signature 656b616d_h to this object the drive switches to TMCL mode. The drive can then only be controlled via TMCL commands written to the OS command object 1023/01_h. The drive can only be reset to normal CANopen functionality using the DS-301 reset application command.



Object Description			
Index	Name	Object Type	Data Type
2700 _h	TMCL Direct Communication	Variable	UNSIGNED32

Table 162: Object Description (2700_h)

Entry Description				
Sub-index	Access	PDO Mapping	Value Range	Default Value
0	rw	no	656b616d _h	0

Table 163: Entry Description (2700_h)

4.2.54 Object 2701_h: Manufacturer Specific Mode

Writing the make signature to this object turns on the manufacturer specific mode. The manufacturer specific mode can be turned off again by writing the kill signature to this object. The manufacturer specific mode has the following features:

- PDOs do not need to be disabled and re-enabled when the PDO mapping is to be changed.
- The RTR bit in the COB-ID of PDO definitions is ignored.

read:	0	=	manufacturer specific mode is inactive
	1	=	manufacturer specific mode is active
write:	656b616d _h	=	make signature
	6c6c696b _h	=	kill signature

Object Description			
Index	Name	Object Type	Data Type
2701 _h	Manufacturer Specific Mode	Variable	UNSIGNED32

Table 164: Object Description (2701_h)

Entry Description				
Sub-index	Access	PDO Mapping	Value Range	Default Value
0	rw	no	see above	0

Table 165: Entry Description (2701_h)

4.2.55 Object 2702_h: Device Digital Inputs

Bits 23...16 of this object reflect the states of the general purpose inputs of the module. The number of available inputs depends on the module type.



Bit Definitions	
Bit	Description
16	IN0
17	IN1
18	IN2
19	IN3

Table 166: Bit Definitions (2702_h)

Object Description			
Index	Name	Object Type	Data Type
2702 _h	Device Digital Inputs	Variable	UNSIGNED32

Table 167: Object Description (2702_h)

Entry Description				
Sub-index	Access	PDO Mapping	Value Range	Default Value
0	ro	yes	-	0

Table 168: Entry Description (2702_h)

4.2.56 Object 2703_h: Device Digital Outputs

With this object the digital outputs (general purpose outputs) can be set. Bits 23...16 of sub index 1 switch the outputs of the module. Bits 23...16 of sub index 2 determine which outputs can be switched. The number of available digital outputs depends on the module type.

Bit Definitions	
Bit	Description
16	OUT0
17	OUT1
18	OUT2
19	OUT3

Table 169: Bit Definitions (2703_h)



Object Description			
Index	Name	Object Type	Data Type
2703 _h	Device Digital Outputs	Variable	ARRAY

Table 170: Object Description (2703_h)

Entry Description					
Sub-index	Description	Access	PDO Mapping	Value Range	Default Value
1	Physical outputs	rw	yes	UNSIGNED32	0
2	Output mask	rw	yes	UNSIGNED32	0

Table 171: Entry Description (2703_h)**Note**

Some outputs can also be used for automatically controlling a brake that can be connected to the module via these outputs. In order to be able to control these outputs via this object the automatic brake control function has to be disabled. Do this by writing 0 to sub-index 1 and sub-index 2 of object 200C_h.

4.2.57 Object 2704_h: CAN Bit Rate

With this object it is possible to change the CAN bit rate. To do this, first write the new value to this object. Then, store the new setting by writing the save signature to object 2706_h. After that, reset the module. The new setting then becomes active.

Object Description			
Index	Name	Object Type	Data Type
2704 _h	CAN Bit Rate	Variable	UNSIGNED16

Table 172: Object Description (2704_h)

Entry Description				
Sub-index	Access	PDO Mapping	Value Range	Default Value
0	rw	no	20,50,100,125,250,500,800,1000	1000

Table 173: Entry Description (2704_h)

How to change the bit rate of a module:

- Write new bit rate in object 2704_h.
- Write the save signature 65766173_h to sub-index 1 of object 2706_h.
- Reset module.



4.2.58 Object 2705_h: Node ID

On modules that do not have address switches the node ID can be selected using this object. On modules with address switches the node ID is normally selected using the address switches. Only when the address switches are set to an invalid value (0 or >127) this object overrides the address switch setting. To change the node ID, first write the new node ID to this object. Then, store the new setting by writing the save signature to object 2706_h. After that, reset the module. The new setting then becomes active.

Object Description			
Index	Name	Object Type	Data Type
2705 _h	Node ID	Variable	UNSIGNED8

Table 174: Object Description (2705_h)

Entry Description				
Sub-index	Access	PDO Mapping	Value Range	Default Value
0	rw	no	1...127	1

Table 175: Entry Description (2705_h)

How to change the node ID of a module:

- Write new node ID to object 2705_h.
- Write save signature 65766173_h to sub-index 1 of object 2706_h.
- Reset the module.

4.2.59 Object 2706_h: Store

Writing the save signature to this object permanently saves changes made to objects 2704_h and 2705_h. The save signature is 65766173_h.

Object Description			
Index	Name	Object Type	Data Type
2706 _h	Store	Variable	UNSIGNED32

Table 176: Object Description (2706_h)

Entry Description				
Sub-index	Access	PDO Mapping	Value Range	Default Value
0	rw	no	save signature: 65766173 _h	1

Table 177: Entry Description (2706_h)



4.2.60 Object 2707_h: CAN Bit Rate Load

This object shows the selected CAN bit rate.

Object Description			
Index	Name	Object Type	Data Type
2707 _h	CAN Bit Rate Load	Variable	UNSIGNED8

Table 178: Object Description (2707_h)

Entry Description				
Sub-index	Access	PDO Mapping	Value Range	Default Value
0	ro	no	20...1000	depends on bit rate

Table 179: Entry Description (2707_h)

4.2.61 Object 2708_h: Node ID Load

This object shows the selected node ID.

Object Description			
Index	Name	Object Type	Data Type
2708 _h	Node ID Load	Variable	UNSIGNED8

Table 180: Object Description (2708_h)

Entry Description				
Sub-index	Access	PDO Mapping	Value Range	Default Value
0	ro	no	1..127	Depends on node ID setting

Table 181: Entry Description (2708_h)

4.2.62 Object 270E_h: Device Analog Inputs

This object shows the values of the analog inputs of the device.

Object Description			
Index	Name	Object Type	Data Type
270E _h	Device Analog Inputs	Array	UNSIGNED32

Table 182: Object Description (270E_h)



Entry Description					
Sub-index	Description	Access	PDO Mapping	Value Range	Default Value
1	Analog input 0	ro	yes	0...65535	-
2	Analog input 1	ro	yes	0...65535	-
3	Analog input 2	ro	yes	0...65535	-
4	Analog input 3	ro	yes	0...65535	-

Table 183: Entry Description (270E_h)



5 Profile specific Area

The profile segment contains CiA-402 standard motion control objects. These objects control the motion control functions of the TMCM-3212. Since it is not possible to operate the modes in parallel, the user is able to activate the required function by selecting a mode of operation. The control device writes to the modes of operation object in order to select the operation mode. The drive device provides the modes of operation display object to indicate the actual activated operation mode. Controlword, statusword, and set-points are used mode-specific. This implies the responsibility of the control device to avoid inconsistencies and erroneous behavior.

The following operating modes (selectable via object 6060_h, please see 5.1.6) are implemented on the TMCM-3212:

- Profile position mode (pp)
- Profile velocity mode (pv)
- Homing mode (hm)
- Cyclic position mode (csp)
- Cyclic velocity mode (csv)

i Info

This section of the manual only shows the object indices for motor #0. Of course the same objects are also available for the other motors. For the other motors, add an offset of $motor_number \cdot 800_h$ to the object index. So for example the control word (object 6040_h for motor #0) can be accessed as object 6840_h for motor #1 and as object 7040_h for motor #2. Please see also section 2.4.1.

Multi-axis Object Indices	
Motor	Object Index Range
Motor #0	6000 _h – 67FF _h
Motor #1	6800 _h – 6FFF _h
Motor #2	7000 _h – 77FF _h

Table 184: Multi-axis Object Indices (Profile specific Area)

5.1 Detailed Object Specifications

5.1.1 Object 605A_h: Quick Stop Option Code

This object indicates what action is performed when the quick stop function is executed. The slow down ramp is the deceleration value of the used mode of operation. The following quick stop option codes are supported in the current version of the CANopen firmware:



Value Definition	
Value	Definition
1	Slow down on <i>slow down ramp</i> and transit into <i>switch on disabled</i>
2	Slow down on <i>quick stop ramp</i> and transit into <i>switch on disabled</i>
5	Slow down on <i>slow down ramp</i> and stay in <i>quick stop active</i>
6	Slow down on <i>quick stop ramp</i> and stay in <i>quick stop active</i>

Table 185: Value Description (605A_h)

Object Description			
Index	Name	Object Type	Data Type
605A _h	Quick stop option code	Variable	SIGNED16

Table 186: Object Description (605A_h)

Entry Description				
Sub-index	Access	PDO Mapping	Value Range	Default Value
0	rw	no	1/2/5/6	2

Table 187: Entry Description (605A_h)

5.1.2 Object 605B_h: Shutdown Option Code

This object indicates what action is performed if there is a transition from *operation enabled* state to *ready to switch on state*. The shutdown option code always has the value 0 as only this is supported.

Value Definition	
Value	Definition
0	Disable drive function (switch off the power stage)

Table 188: Value Description (605B_h)

Object Description			
Index	Name	Object Type	Data Type
605B _h	Shutdown option code	Variable	UNSIGNED16

Table 189: Object Description (605B_h)



Entry Description				
Sub-index	Access	PDO Mapping	Value Range	Default Value
0	rw	no	0	0

Table 190: Entry Description (605B_h)

5.1.3 Object 605C_h: Disable Operation Option Code

This object indicates what action is performed if there is a transition from *operation enabled* state to *switched on* state. The disable operation option code always has the value 1 as only this is supported. The slow down ramp is the deceleration value of the used mode of operation.

Value Definition	
Value	Definition
1	Slow down on slow down ramp

Table 191: Value Description (605C_h)

Object Description			
Index	Name	Object Type	Data Type
605C _h	Disable operation option code	Variable	UNSIGNED16

Table 192: Object Description (605C_h)

Entry Description				
Sub-index	Access	PDO Mapping	Value Range	Default Value
0	rw	no	1	1

Table 193: Entry Description (605C_h)

5.1.4 Object 605D_h: Halt Option Code

This object indicates what action is performed when the halt function is executed. The slow down ramp is the deceleration value of the used mode of operation. The halt option code always has the value 1 as only this is supported.

Value Definition	
Value	Definition
1	Slow down on slow down ramp and stay in <i>operation enabled</i>

Table 194: Value Description (605D_h)



Object Description			
Index	Name	Object Type	Data Type
605D _h	Halt option code	Variable	UNSIGNED16

Table 195: Object Description (605D_h)

Entry Description				
Sub-index	Access	PDO Mapping	Value Range	Default Value
0	rw	no	1	1

Table 196: Entry Description (605D_h)

5.1.5 Object 605E_h: Fault Reaction Option Code

This object indicates what action is performed when fault is detected in the power drive system. The slow down ramp is the deceleration value of the used mode of operation. The fault reaction option code always has the value 2 as only this is supported.

Value Definition	
Value	Definition
2	Slow down on quick stop ramp

Table 197: Value Description (605E_h)

Object Description			
Index	Name	Object Type	Data Type
605E _h	Fault reaction option code	Variable	UNSIGNED16

Table 198: Object Description (605E_h)

Entry Description				
Sub-index	Access	PDO Mapping	Value Range	Default Value
0	rw	no	2	2

Table 199: Entry Description (605E_h)

5.1.6 Object 6060_h: Modes of Operation

This object indicates the requested operation mode. Supported operating modes are:



Value Definition	
Value	Mode
0	No mode
1	Profile position mode (pp)
3	Profile velocity mode (pv)
6	Homing mode (hm)
8	Cyclic synchronous position mode (csp)
9	Cyclic synchronous velocity mode (csv)

Table 200: Value Description (6060_h)

The motor will not run when the operating mode is set to 0. It will be stopped when the motor is running in one of the supported operating modes and the operating mode is then switched to 0.

Object Description			
Index	Name	Object Type	Data Type
6060 _h	Modes of operation	Variable	SIGNED8

Table 201: Object Description (6060_h)

Entry Description				
Sub-index	Access	PDO Mapping	Value Range	Default Value
0	rw	refer to CiA-402	see table 200	0

Table 202: Entry Description (6060_h)

Note It is not allowed to write the same mode number twice to object 6060_h. So before writing a new value to object 6060_h, either check object 6061_h or object 6060_h to see if the operating mode has not already been set to that value.

5.1.7 Object 6061_h: Modes of Operation Display

This object shows the operating mode that is currently set.



Value Definition	
Value	Mode
0	No mode
1	Profile position mode (pp)
3	Profile velocity mode (pv)
6	Homing mode (hm)
8	Cyclic synchronous position mode (csp)
9	Cyclic synchronous velocity mode (csv)

Table 203: Value Description (6061_h)

The motor will not run when the operating mode is set to 0. It will be stopped when the motor is running in one of the supported operating modes and the operating mode is then switched to 0.

Object Description			
Index	Name	Object Type	Data Type
6061 _h	Modes of operation display	Variable	SIGNED8

Table 204: Object Description (6061_h)

Entry Description				
Sub-index	Access	PDO Mapping	Value Range	Default Value
0	rw	refer to CiA-402	see table 203	0

Table 205: Entry Description (6061_h)

5.1.8 Object 606A_h: Sensor Selection Code

This object provides the source of the position sensor actual value. It selects whether an encoder is to be used or not.

Value Definition	
Value	Mode
0	Encoder used
-1	No encoder

Table 206: Value Description (606A_h)



Object Description			
Index	Name	Object Type	Data Type
606A _h	Sensor selection code	Variable	SIGNED16

Table 207: Object Description (606A_h)

Entry Description				
Sub-index	Access	PDO Mapping	Value Range	Default Value
0	rw	no	0/-1	-1

Table 208: Entry Description (606A_h)

5.1.9 Object 608F_h: Position Encoder Resolution

This object defines the resolution of the encoder. The position encoder resolution is calculated by the following formula:

$$position\ encoder\ resolution = \frac{encoder\ increments}{motor\ revolutions}$$

All values are dimensionless.

Object Description			
Index	Name	Object Type	Data Type
608F _h	Position Encoder Resolution	Array	UNSIGNED32

Table 209: Object Description (608F_h)

Entry Description					
Sub-index	Description	Access	PDO Mapping	Value Range	Default Value
0	Highest sub-index supported	ro	no	2	2
1	Encoder increments	rw	no	0...2147483647	1
2	Motor revolutions	ro	no	1	1

Table 210: Entry Description (608F_h)

5.1.10 Object 60FD_h: Digital Inputs

This object contains the states of the digital inputs of the module. Starting from bit 0, every bit reflects the state of one digital input. The number of valid bits depends on the number of digital inputs on the module used.



Object Description			
Index	Name	Object Type	Data Type
60FD _h	Digital inputs	Variable	UNSIGNED32

Table 211: Object Description (60FD_h)

Entry Description				
Sub-index	Access	PDO Mapping	Value Range	Default Value
0	rw	mappable	UNSIGNED32	0

Table 212: Entry Description (60FD_h)

5.1.11 Object 6502_h: Supported Drive Modes

This object provides information on the supported drive modes. A bit that is set means that the mode is supported, a bit that is not set means that the mode is not supported by the drive.

Value Definition	
Bit	Mode
0	Profile position mode (pp)
1	Velocity mode (vl)
2	Profile velocity mode (pv)
3	Torque mode (tq)
4	Reserved
5	Homing mode (hm)
6	Interpolated position mode (ip)
7	Cyclic synchronous position mode (csp)
8	Cyclic synchronous velocity mode (csv)
9	Cyclic synchronous torque mode (cst)

Table 213: Value Definition (6502_h)

Object Description			
Index	Name	Object Type	Data Type
6502 _h	Supported drive modes	Variable	UNSIGNED32

Table 214: Object Description (6502_h)



Entry Description				
Sub-index	Access	PDO Mapping	Value Range	Default Value
0	ro	no	UNSIGNED32	Depends on supported modes.

Table 215: Entry Description (6502_h)



6 Profile Position Mode

A target position is applied to the trajectory generator. It is generating a position demand value for the position control loop described in the position control function.

Please refer to object 6060_h (section 5.1.6) for information about how to choose an operation mode. Object 6061_h (section 5.1.7) shows the operation mode that is set.

6.1 Detailed Object Specifications

The following text offers detailed object specifications. For a better understanding, it is necessary to see how the state machine works.

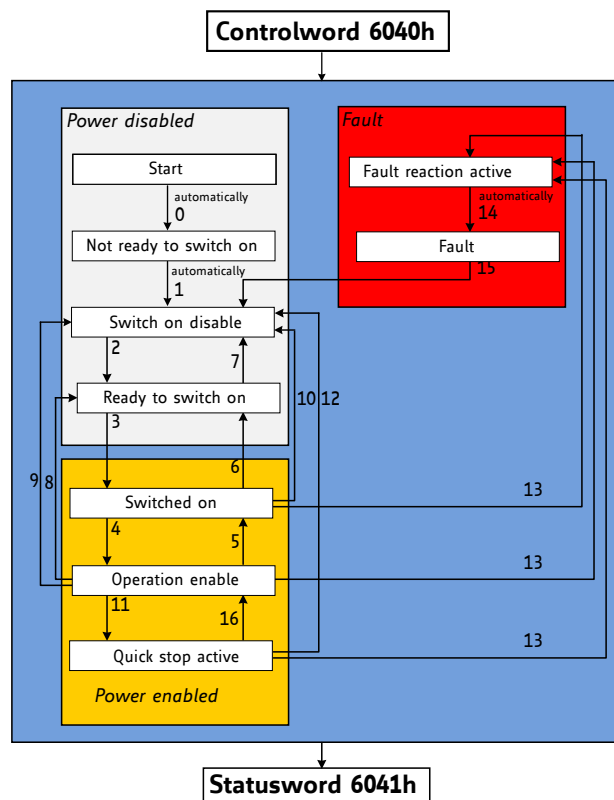

Figure 9: DS402 Finite State Machine

Notes on state transitions:

- Commands directing a change in state are processed completely and the new state achieved before additional state change commands are processed.
- Transitions 0 and 1 occur automatically at drive power-on or reset. Transition 14 occurs automatically, too. All other state changes must be directed by the host.
- Drive function disabled indicates that no current is being supplied to the motor.
- Drive function enabled indicates that current is available for the motor and profile position and profile velocity reference values may be processed.



6.1.1 Object 6040_n: Control Word

This object indicates the received command controlling the power drive system finite state automaton (PDS FSA). The CiA-402 state machine can be controlled using this object. Please refer to figure 9 for detailed information.

Structure of the Control Word											
15	11	10	9	8	7	6	4	3	2	1	0
nu	r	oms	h	fr	oms	eo	qs	ev	so		
MSB										LSB	

Legend: nu=not used; r=reserved; oms=operation mode specific; h=halt; fr=fault reset; eo=enable operation; qs=quick stop; ev=enable voltage; so=switch on.

Table 216: Structure of the Control Word in pp Mode

Operation Mode specific Bits in pp Mode		
Bit	Name	Definition
4	New set point	0-to-1: the next positioning will be started.
5	Change immediately	Not supported.
6	Absolute / relative	0: New position is absolute. 1: New position is relative.
9	Change set point	Not supported.

Table 217: Operation Mode specific Bits in pp Mode

Command Coding						
Command	Bits of Control Word					Transitions
	Bit 7	Bit 3	Bit 2	Bit 1	Bit 0	
Shutdown	0	x	1	1	0	2,6,8
Switch on	0	0	1	1	1	3
Switch on & enable operation	0	1	1	1	1	3, 4
Disable voltage	0	x	x	0	x	7,9,10,12
Quick stop	0	x	0	1	x	7,10,11
Disable operation	0	0	1	1	1	5
Enable operation	0	1	1	1	1	4, 16
Fault reset	0-to-1	x	x	x	x	15

Table 218: Command Coding



Object Description			
Index	Name	Object Type	Data Type
6040 _h	Controlword	Variable	UNSIGNED16

Table 219: Object Description (6040_h in pp Mode)

Entry Description				
Sub-index	Access	PDO Mapping	Value Range	Default Value
0	rw	see CiA402-3	See command coding above.	

Table 220: Entry Description (6040_h in pp Mode)

6.1.2 Object 6041_h: Status Word

This object provides the status of the PDS FSA. It reflects the status of the CiA-402 state machine. Please refer to figure 9 for detailed information. The object is structured as defined below. For more information about the coding please refer to the CANopen Drives and motion control device profile, part 2.

Structure of the Status Word															
15	14	13	12	11	10	9	8	7	6	5	4	3	2	1	0
dir	mot	oms	ila	tr	rm	ms	w	sod	qs	ve	f	oe	so	rtso	
MSB														LSB	

Legend: nu=not used; r=reserved; oms=operation mode specific; h=halt; fr=fault reset; oe=operation enable; qs=quick stop; ve=voltage enable; so=switch on.

Table 221: Structure of the Status Word in pp Mode

Trinamic Specific Bits		
Bit	Name	Definition
14	Motor activity	0: Motor stands still. 1: Motor rotates.
15	Direction of rotation	This bit shows the direction of rotation.

Table 222: Trinamic Specific Bits



Operation Mode specific Bits in pp Mode		
Bit	Name	Definition
10	Target reached	Set when the motor is within the position window.
12	Set point acknowledged	0: Set point processed. 1: Set point still in process.
13	Following error	Not supported.

Table 223: Operation Mode specific Bits in pp Mode

State Coding	
Status word	FSA state
xxxx xxxx x0xx 0000 _h	Not ready to switch on
xxxx xxxx x1xx 0000 _h	Switch on disabled
xxxx xxxx x01x 0001 _h	Ready to switch on
xxxx xxxx x01x 0011 _h	Switched on
xxxx xxxx x01x 0111 _h	Operation enabled
xxxx xxxx x00x 0111 _h	Quick stop active
xxxx xxxx x0xx 1111 _h	Fault reaction active
xxxx xxxx x0xx 1000 _h	Fault

Table 224: State Coding

Object Description			
Index	Name	Object Type	Data Type
6041 _h	Controlword	Variable	UNSIGNED16

Table 225: Object Description (6041_h in pp Mode)

Entry Description				
Sub-index	Access	PDO Mapping	Value Range	Default Value
0	rw	see CiA402-3	See state coding above.	

Table 226: Entry Description (6041_h in pp Mode)

6.1.3 Object 6062_h: Position Demand Value

This object provides the demanded position value. The value is given in microsteps. Object 6062_h indicates the actual position that the motor should have. It is not to be confused with objects 6063_h and 6064_h.



Object Description			
Index	Name	Object Type	Data Type
6062 _h	Position Demand Value	Variable	SIGNED32

Table 227: Object Description (6062_h)

Entry Description				
Sub-index	Access	PDO Mapping	Value Range	Default Value
0	ro	Refer to CiA402-3	SIGNED32	no

Table 228: Entry Description (6062_h)

6.1.4 Object 6063_h: Position Actual Internal Value

This object provides the actual value of the encoder or the motor. Please use the sensor selection object 606A_h (see section 5.1.8) for selecting the motor or the encoder first. Object 6063_h indicates the actual position of the encoder or the motor, re-scaled to the microstep resolution. The value is given in microsteps.

Object Description			
Index	Name	Object Type	Data Type
6063 _h	Position Actual Internal Value	Variable	SIGNED32

Table 229: Object Description (6063_h)

Entry Description				
Sub-index	Access	PDO Mapping	Value Range	Default Value
0	ro	Refer to CiA402-3	SIGNED32	no

Table 230: Entry Description (6063_h)

6.1.5 Object 6064_h: Position Actual Value

This object provides the actual value of the position measurement device. It always contains the same value as object 6063_h.

Object Description			
Index	Name	Object Type	Data Type
6064 _h	Position Actual Value	Variable	SIGNED32

Table 231: Object Description (6064_h)

Entry Description				
Sub-index	Access	PDO Mapping	Value Range	Default Value
0	ro	Refer to CiA402-3	SIGNED32	no

Table 232: Entry Description (6064_h)

6.1.6 Object 6065_h: Following Error Window

This object indicates the configured range of tolerated position values symmetrically to the position demand value. If the position actual value is out of the following error window, a following error occurs. A following error may occur when a drive is blocked, unreachable profile velocity occurs, or at wrong closed-loop coefficients. The value shall be given in microsteps.

When the difference between motor position (object 6062_h) and encoder position (object 6063_h or 6064_h) is greater than the value set here, the motor will be stopped and an emergency message will be sent. Setting this object to zero will turn off this feature completely.

Note Setting this object to a too low value will lead to false alarms.

Object Description			
Index	Name	Object Type	Data Type
6065 _h	Following Error Window	Variable	UNSIGNED32

Table 233: Object Description (6065_h)

Entry Description				
Sub-index	Access	PDO Mapping	Value Range	Default Value
0	rw	no	0...2147483647	0

Table 234: Entry Description (6065_h)

6.1.7 Object 6067_h: Position Window

This object indicates the configured symmetrical range of accepted positions relative to the target position. If the actual value of the position encoder is within the position window, this target position is regarded as having been reached. The value is given in increments. If the value of the position window is FFFFFFFF_h, the position window control is switched off. If this object is set to zero, the target reached event will be signaled when the demand position (6062_h) has reached the target position (6064_h). When the position window is set to a value greater than zero, the target reached event will be signaled when the actual encoder position value (6064_h) is within $(target_position - position_window)$ and $(target_position + position_window)$.



Object Description			
Index	Name	Object Type	Data Type
6067 _h	Position Window	Variable	UNSIGNED32

Table 235: Object Description (6067_h)

Entry Description				
Sub-index	Access	PDO Mapping	Value Range	Default Value
0	rw	no	UNSIGNED32	FFFFFFF _h

Table 236: Entry Description (6067_h)

6.1.8 Object 6068_h: Position Window Time

This object indicates the configured time, during which the actual position within the position window is measured. The value is given in ms. If this object is set to a value greater than zero and also the position window (6067_h) is set to a value greater than zero the target reached event will not be signaled until the actual position (6064_h) is at least as many milliseconds within the position window as defined by this object.

Object Description			
Index	Name	Object Type	Data Type
6068 _h	Position Window Time	Variable	UNSIGNED16

Table 237: Object Description (6068_h)

Entry Description				
Sub-index	Access	PDO Mapping	Value Range	Default Value
0	rw	no	UNSIGNED16	0

Table 238: Entry Description (6068_h)

6.1.9 Object 606C_h: Velocity Actual Value

This object shows the actual velocity value of the motor. The value is given in internal or user-defined velocity units (depending on object 208C_h, described in section 4.2.17).

Object Description			
Index	Name	Object Type	Data Type
606C _h	Velocity Actual Value	Variable	SIGNED32

Table 239: Object Description (606C_h)



Entry Description				
Sub-index	Access	PDO Mapping	Value Range	Default Value
0	ro	Refer to CiA402-3	SIGNED32	no

Table 240: Entry Description (606C_h)

6.1.10 Object 607A_h: Target Position

The target position is the position that the drive should move to in profile position mode using the current settings of motion control parameters (such as velocity, acceleration, deceleration, motion profile type etc.). The value of this object is interpreted as absolute or relative depending on the abs/rel flag in the controlword. It is given in microsteps.

Object Description			
Index	Name	Object Type	Data Type
607A _h	Target Position	Variable	SIGNED32

Table 241: Object Description (607A_h in pp Mode)

Entry Description				
Sub-index	Access	PDO Mapping	Value Range	Default Value
0	rw	Refer to CiA402-3	SIGNED32	0

Table 242: Entry Description (607A_h in pp Mode)

6.1.11 Object 607D_h: Software Position Limit

This object indicates the configured maximal and minimal software position limits. These parameters define the absolute position limits for the position demand value and the position actual value. Every new target position is checked against these limits. The limit positions are always relative to the machine home position. Before being compared with the target position, they are corrected internally by the home offset as follows:

$$\begin{aligned} \text{Corrected_min_position_limit} &= \text{min_position_limit} - \text{home_offset} \\ \text{Corrected_max_position_limit} &= \text{max_position_limit} - \text{home_offset} \end{aligned}$$

Object Description			
Index	Name	Object Type	Data Type
607D _h	Software Position Limit	Array	SIGNED32

Table 243: Object Description (607D_h)



Entry Description					
Sub-index	Description	Access	PDO Mapping	Value Range	Default Value
1	Minimum Position Limit	rw	no	SIGNED32	-2147483648
2	Maximum Position Limit	rw	no	SIGNED32	2147483647

Table 244: Entry Description (607D_h)

6.1.12 Object 6081_h: Profile Velocity

This object indicates the configured velocity normally attained at the end of the acceleration ramp during a profiled motion and is valid for both directions of motion. The profile velocity is the maximum velocity used when driving to a new position. It is given in internal or user specific units (depending on object 208C_h, section 4.2.17).

Object Description			
Index	Name	Object Type	Data Type
6081 _h	Profile Velocity	Variable	SIGNED32

Table 245: Object Description (6081_h)

Entry Description				
Sub-index	Access	PDO Mapping	Value Range	Default Value
0	rw	no	SIGNED32	0

Table 246: Entry Description (6081_h)

6.1.13 Object 6082_h: End Velocity

This object indicates the configured velocity normally attained at the end of the deceleration ramp during a profiled motion and is valid for both directions of motion. The end velocity is the velocity used when reaching the new position. It is given in internal or user specific units (depending on object 208C_h, section 4.2.17).

Object Description			
Index	Name	Object Type	Data Type
6082 _h	End Velocity	Variable	SIGNED32

Table 247: Object Description (6082_h)

Entry Description				
Sub-index	Access	PDO Mapping	Value Range	Default Value
0	rw	no	SIGNED32	0

Table 248: Entry Description (6082_h)



6.1.14 Object 6083_h: Profile Acceleration

This object indicates the configured acceleration. Object 6083_h sets the maximum acceleration to be used in profile position and profile velocity mode.

The units for object 6083_h can be chosen with object 208E_h, described in section 4.2.18.

In profile velocity mode, this object also sets the deceleration to be used (the deceleration ramp is always the same as the acceleration ramp in pv mode).

Object Description			
Index	Name	Object Type	Data Type
6083 _h	Profile Acceleration	Variable	SIGNED32

Table 249: Object Description (6083_h)

Entry Description				
Sub-index	Access	PDO Mapping	Value Range	Default Value
0	rw	no	SIGNED32	0

Table 250: Entry Description (6083_h)

6.1.15 Object 6084_h: Profile Deceleration

This object indicates the configured deceleration. Object 6084_h sets the maximum deceleration to be used in profile positioning mode.

The units for object 6084_h can be chosen with object 208E_h, described in section 4.2.18.

Object Description			
Index	Name	Object Type	Data Type
6084 _h	Profile Deceleration	Variable	SIGNED32

Table 251: Object Description (6084_h)

Entry Description				
Sub-index	Access	PDO Mapping	Value Range	Default Value
0	rw	no	SIGNED32	0

Table 252: Entry Description (6084_h)

6.1.16 Object 6085_h: Quick Stop Deceleration

This object indicates the configured deceleration used to stop the motor when the quick stop function is activated and the quick stop code object 605A_h is set to 2 (or 6). The value is given in the same unit as profile acceleration object 6083_h.



Object Description			
Index	Name	Object Type	Data Type
6085 _h	Quick stop deceleration	Variable	UNSIGNED32

Table 253: Object Description (6085_h)

Entry Description				
Sub-index	Access	PDO Mapping	Value Range	Default Value
0	rw	no	UNSIGNED32	51200

Table 254: Entry Description (6085_h)

6.1.17 Object 60F2_h: Positioning Option Code

This object indicates the positioning behaviour in profile position mode. Only bits 0 and 1 (relative option) are supported.

Bit Definitions		
Bit 1	Bit 0	Definition
0	0	Positioning moves shall be performed relative to the preceding (internal absolute) target position.
0	1	Positioning moves shall be performed relative to the actual position demand value (object 6063 _h).
1	0	Positioning moves shall be performed relative to the position actual value (object 6064 _h).
1	1	reserved

Table 255: Bit Definitions of Object 60F2_h

Object Description			
Index	Name	Object Type	Data Type
60F2 _h	Positioning option code	Variable	UNSIGNED16

Table 256: Object Description (60F2_h)

Entry Description				
Sub-index	Access	PDO Mapping	Value Range	Default Value
0	rw	no	UNSIGNED16	0

Table 257: Entry Description (60F2_h)



6.2 How to move a Motor in pp Mode

Here is a little example that shows how to get a motor running in pp mode. In this little example we assume that the module has been reset (and then switched to pre-operational or operational) by NMT commands before. Please note that the values are decimal.

- If you do not have any limit switches connected, first disable the limit switch inputs by writing 3 to object 2005_h.
- Select pp mode by writing 1 to object 6060_h.
- Write 6 to object 6040_h to switch to READY_TO_SWITCH_ON state.
- Write 7 to object 6040_h to switch to SWITCHED_ON state.
- Write 15 to object 6040_h to switch to OPERATION_ENABLED state.
- Write the desired target position (e.g. 500000) to object 607A_h.
- Mark the new target position as active by writing 31 to object 6040_h. The motor starts moving now.
- Reset the activation by writing 15 to object 6040_h (this can be done while the motor is still moving).



7 Profile Velocity Mode

The profile velocity mode is used to control the velocity of the drive without a special regard of the position. It contains limit functions and trajectory generation.

The profile velocity mode covers the following sub-functions:

- Demand value input via trajectory generator.
- Monitoring of the profile velocity using a window-function.
- Monitoring of velocity actual value using a threshold.

The operation of the reference value generator and its input parameters include:

- Profile velocity
- Profile acceleration
- Profile deceleration
- Emergency stop
- Motion profile type

7.1 Detailed Object Specifications

7.1.1 Object 6040_n: Control Word

This object indicates the received command controlling the power drive system finite state automaton (PDS FSA). The CiA-402 state machine can be controlled using this object. Please refer to figure 9 for detailed information.

In pv mode the control word does not contain any operation mode specific bits.

Structure of the Control Word											
15	11	10	9	8	7	6	4	3	2	1	0
nu	r	r	h	fr	r	eo	qs	ev	so		
MSB										LSB	

Legend: nu=not used; r=reserved; h=halt; fr=fault reset; eo=enable operation; qs=quick stop; ev=enable voltage; so=switch on.

Table 258: Structure of the Control Word in pv Mode



Command Coding						
Command	Bits of Control Word					Transitions
	Bit 7	Bit 3	Bit 2	Bit 1	Bit 0	
Shutdown	0	x	1	1	0	2,6,8
Switch on	0	0	1	1	1	3
Switch on & enable operation	0	1	1	1	1	3, 4
Disable voltage	0	x	x	0	x	7,9,10,12
Quick stop	0	x	0	1	x	7,10,11
Disable operation	0	0	1	1	1	5
Enable operation	0	1	1	1	1	4, 16
Fault reset	0-to-1	x	x	x	x	15

Table 259: Command Coding

Object Description			
Index	Name	Object Type	Data Type
6040 _h	Controlword	Variable	UNSIGNED16

Table 260: Object Description (6040_h in pv Mode)

Entry Description				
Sub-index	Access	PDO Mapping	Value Range	Default Value
0	rw	see CiA402-3	See command coding above.	

Table 261: Entry Description (6040_h in pv Mode)

7.1.2 Object 6041_h: Status Word

This object provides the status of the PDS FSA. It reflects the status of the CiA-402 state machine. Please refer to figure 9 for detailed information. The object is structured as defined below. For more information about the coding please refer to the CANopen Drives and motion control device profile, part 2.

Structure of the Status Word															
15	14	13	12	11	10	9	8	7	6	5	4	3	2	1	0
dir	mot	oms	ila	tr	rm	ms	w	sod	qs	ve	f	oe	so	rtso	
MSB														LSB	

Legend: nu=not used; r=reserved; oms=operation mode specific; h=halt; fr=fault reset; oe=operation enable; qs=quick stop; ve=voltage enable; so=switch on.

Table 262: Structure of the Status Word in pv Mode



Trinamic Specific Bits		
Bit	Name	Definition
14	Motor activity	0: Motor stands still. 1: Motor rotates.
15	Direction of rotation	This bit shows the direction of rotation.

Table 263: Trinamic Specific Bits

Operation Mode specific Bits in pv Mode		
Bit	Name	Definition
10	Target reached	Indicates that the target speed has been reached.
12	Speed	Not supported.
13	Max. slippage error	Not supported.

Table 264: Operation Mode specific Bits in pv Mode

State Coding	
Status word	FSA state
xxxx xxxx x0xx 0000 _h	Not ready to switch on
xxxx xxxx x1xx 0000 _h	Switch on disabled
xxxx xxxx x01x 0001 _h	Ready to switch on
xxxx xxxx x01x 0011 _h	Switched on
xxxx xxxx x01x 0111 _h	Operation enabled
xxxx xxxx x00x 0111 _h	Quick stop active
xxxx xxxx x0xx 1111 _h	Fault reaction active
xxxx xxxx x0xx 1000 _h	Fault

Table 265: State Coding

Object Description			
Index	Name	Object Type	Data Type
6041 _h	Controlword	Variable	UNSIGNED16

Table 266: Object Description (6041_h in pv Mode)



Entry Description				
Sub-index	Access	PDO Mapping	Value Range	Default Value
0	rw	see CiA402-3	See state coding above	

Table 267: Entry Description (6041_h in pv Mode)

7.1.3 Object 6062_h: Position Demand Value

This object provides the demanded position value. The value is given in microsteps. Object 6062_h indicates the actual position that the motor should have. It is not to be confused with objects 6063_h and 6064_h.

Object Description			
Index	Name	Object Type	Data Type
6062 _h	Position Demand Value	Variable	SIGNED32

Table 268: Object Description (6062_h)

Entry Description				
Sub-index	Access	PDO Mapping	Value Range	Default Value
0	ro	Refer to CiA402-3	SIGNED32	no

Table 269: Entry Description (6062_h)

7.1.4 Object 6063_h: Position Actual Internal Value

This object provides the actual value of the encoder or the motor. Please use the sensor selection object 606A_h (see section 5.1.8) for selecting the motor or the encoder first. Object 6063_h indicates the actual position of the encoder or the motor, re-scaled to the microstep resolution. The value is given in microsteps.

Object Description			
Index	Name	Object Type	Data Type
6063 _h	Position Actual Internal Value	Variable	SIGNED32

Table 270: Object Description (6063_h)

Entry Description				
Sub-index	Access	PDO Mapping	Value Range	Default Value
0	ro	Refer to CiA402-3	SIGNED32	no

Table 271: Entry Description (6063_h)

7.1.5 Object 6064_h: Position Actual Value

This object provides the actual value of the position measurement device. It always contains the same value as object 6063_h.

Object Description			
Index	Name	Object Type	Data Type
6064 _h	Position Actual Value	Variable	SIGNED32

Table 272: Object Description (6064_h)

Entry Description				
Sub-index	Access	PDO Mapping	Value Range	Default Value
0	ro	Refer to CiA402-3	SIGNED32	no

Table 273: Entry Description (6064_h)

7.1.6 Object 6065_h: Following Error Window

This object indicates the configured range of tolerated position values symmetrically to the position demand value. If the position actual value is out of the following error window, a following error occurs. A following error may occur when a drive is blocked, unreachable profile velocity occurs, or at wrong closed-loop coefficients. The value shall be given in microsteps.

When the difference between motor position (object 6062_h) and encoder position (object 6063_h or 6064_h) is greater than the value set here, the motor will be stopped and an emergency message will be sent. Setting this object to zero will turn off this feature completely.

Note Setting this object to a too low value will lead to false alarms.

Object Description			
Index	Name	Object Type	Data Type
6065 _h	Following Error Window	Variable	UNSIGNED32

Table 274: Object Description (6065_h)

Entry Description				
Sub-index	Access	PDO Mapping	Value Range	Default Value
0	rw	no	0...2147483647	0

Table 275: Entry Description (6065_h)



7.1.7 Object 606C_h: Velocity Actual Value

This object shows the actual velocity value of the motor. The value is given in internal or user-defined velocity units (depending on object 208C_h, described in section 4.2.17).

Object Description			
Index	Name	Object Type	Data Type
606C _h	Velocity Actual Value	Variable	SIGNED32

Table 276: Object Description (606C_h)

Entry Description				
Sub-index	Access	PDO Mapping	Value Range	Default Value
0	ro	Refer to CiA402-3	SIGNED32	no

Table 277: Entry Description (606C_h)

7.1.8 Object 607D_h: Software Position Limit

This object indicates the configured maximal and minimal software position limits. These parameters define the absolute position limits for the position demand value and the position actual value. Every new target position is checked against these limits. The limit positions are always relative to the machine home position. Before being compared with the target position, they are corrected internally by the home offset as follows:

$$\text{Corrected_min_position_limit} = \text{min_position_limit} - \text{home_offset}$$

$$\text{Corrected_max_position_limit} = \text{max_position_limit} - \text{home_offset}$$

Object Description			
Index	Name	Object Type	Data Type
607D _h	Software Position Limit	Array	SIGNED32

Table 278: Object Description (607D_h)

Entry Description					
Sub-index	Description	Access	PDO Mapping	Value Range	Default Value
1	Minimum Position Limit	rw	no	SIGNED32	-2147483648
2	Maximum Position Limit	rw	no	SIGNED32	2147483647

Table 279: Entry Description (607D_h)



7.1.9 Object 6083_h: Profile Acceleration

This object indicates the configured acceleration. Object 6083_h sets the maximum acceleration to be used in profile position and profile velocity mode.

The units for object 6083_h can be chosen with object 208E_h, described in section 4.2.18.

In profile velocity mode, this object also sets the deceleration to be used (the deceleration ramp is always the same as the acceleration ramp in pv mode).

Object Description			
Index	Name	Object Type	Data Type
6083 _h	Profile Acceleration	Variable	SIGNED32

Table 280: Object Description (6083_h)

Entry Description				
Sub-index	Access	PDO Mapping	Value Range	Default Value
0	rw	no	SIGNED32	0

Table 281: Entry Description (6083_h)

7.1.10 Object 6085_h: Quick Stop Deceleration

This object indicates the configured deceleration used to stop the motor when the quick stop function is activated and the quick stop code object 605A_h is set to 2 (or 6). The value is given in the same unit as profile acceleration object 6083_h.

Object Description			
Index	Name	Object Type	Data Type
6085 _h	Quick stop deceleration	Variable	UNSIGNED32

Table 282: Object Description (6085_h)

Entry Description				
Sub-index	Access	PDO Mapping	Value Range	Default Value
0	rw	no	UNSIGNED32	51200

Table 283: Entry Description (6085_h)

7.1.11 Object 60FF_h: Target Velocity

This object indicates the configured target velocity and is used as input for the trajectory generator. Object 60FF_h sets the target velocity when using profile velocity mode. The drive then accelerates or decelerates to that velocity using the acceleration and deceleration set by objects 6083_h and 6084_h. The values are given in units which can be selected with object 208C_h, described in section 4.2.17.



Object Description			
Index	Name	Object Type	Data Type
60FF _h	Target Velocity	Variable	SIGNED32

Table 284: Object Description (60FF_h)

Entry Description				
Sub-index	Access	PDO Mapping	Value Range	Default Value
0	rw	see CiA402-3	SIGNED32	0

Table 285: Entry Description (60FF_h)

7.2 How to move a Motor in pv Mode

Here is a little example that shows how to get a motor running in pv mode. In this little example we assume that the module has been reset (and then switched to pre-operational or operational) by NMT commands before.

- If you do not have any limit switches connected, first disable the limit switch inputs by writing 3 to object 2005_h.
- Select pv mode by writing 3 to object 6060_h.
- Write 6 to object 6040_h to switch to READY_TO_SWITCH_ON state.
- Write 7 to object 6040_h to switch to SWITCHED_ON state.
- Write 15 to object 6040_h to switch to OPERATION_ENABLED state.
- Write the desired target speed (e.g. 100000) to object 60FF_h. The motor now accelerates to that speed.
- Stop the motor by writing 0 to object 60FF_h.



8 Homing Mode

This chapter describes the method by which a drive seeks the home position (reference point). There are various methods of achieving this using limit switches at the ends of travel or a home switch in mid-travel. Some methods also use the index (zero) pulse train from an incremental encoder. The user may specify the speeds, acceleration and the method of homing.

There is no output data except for those bits in the statusword which return the status or result of the homing process and the demand to the position control loops.

There are four sources of the homing signal available: these are positive and negative limit switches, the home switch and the index pulse from an encoder.

Figure 10 shows the defined input objects as well as the output objects. The user can specify the speeds, acceleration and method of homing. The home offset object 607C_h allows displacing the zero in point the coordinate system for the home position.

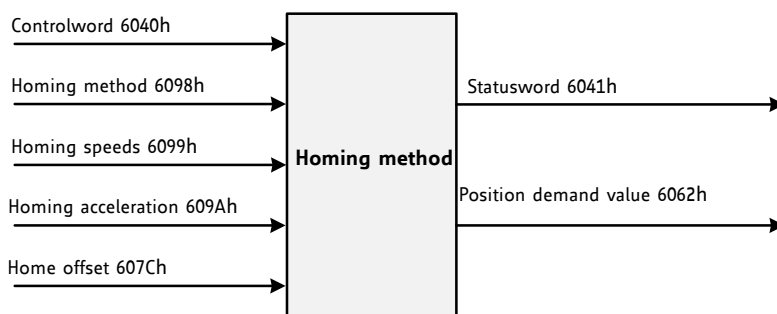

Figure 10: Homing Mode Function

Choosing a homing mode determines the following things:

- The homing signal (positive limit switch, negative limit switch, and home switch).
- The direction of actuation where appropriate.
- The position of the index pulse.

The home position and the zero position are offset by the home offset (see object 607C_h, section 8.2.4).

Depending on the module there are different sources of homing methods available:

- Negative and positive limit switches.
- Home switch.
- Index pulse of an encoder.

For the operation of positioning drives, an exact knowledge of the absolute position is normally required. Since for cost reasons drives often do not have an absolute encoder, a homing operation is necessary.



8.1 Homing Methods

The TMCM-3212 supports a subset of different standard CANopen homing methods. The homing method that is to be used can be chosen via object 6098_h (section 8.2.5).

Supported Homing Methods	
Method	Description
0	No homing (default value for object 6098 _h).
1	Search the left end switch, then search the next encoder index pulse.
2	Search the right end switch, then search the next encoder index pulse.
3	Search the positive edge of the home switch, then search the next encoder index pulse.
5	Search the negative edge of the home switch, then search the next encoder index pulse.
17	Search the left end switch.
18	Search the right end switch.
19	Search the positive edge of the home switch.
21	Search the negative edge of the home switch.
33	Search next index pulse in negative direction.
34	Search next index pulse in positive direction.
35	The actual position is used as home position. All position values (objects 6062h, 6063h, and 6064h) are set to zero, but the motor will not move.

Table 286: Supported CANopen Homing Methods

When using homing methods that need end switch inputs or home switch inputs please take care of their configuration (object 2005_h, section 4.2.6).

8.1.1 Homing Method 1: Homing on negative Limit Switch and Index Pulse

Using this method, the initial direction of movement shall be leftward if the negative limit switch is inactive (here: low). The home position shall be at the first index pulse to the right of the position where the negative limit switch becomes inactive.

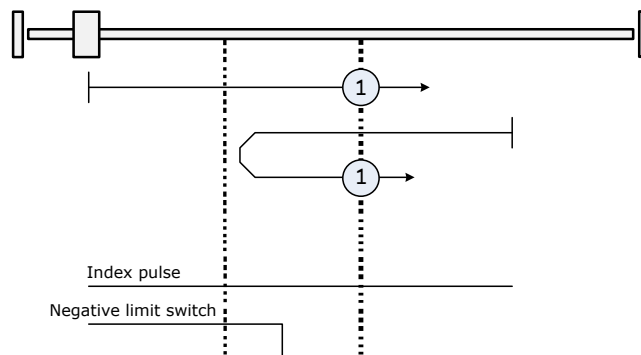

Figure 11: Homing Method 1



8.1.2 Homing Method 2: Homing on positive Limit Switch and Index Pulse

Using this method, the initial direction of movement shall be rightward if the positive limit switch is inactive (here: low). The position of home shall be at the first index pulse to the left of the position where the positive limit switch becomes inactive.

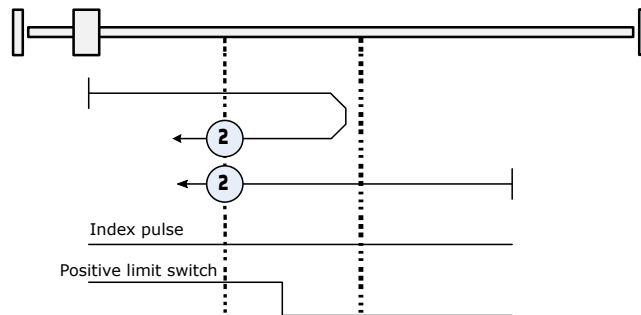

Figure 12: Homing Method 2

8.1.3 Homing Method 3: Homing on positive Home Switch and Index Pulse

Using this method, the initial direction of movement shall be dependent on the state of the home switch. The home position shall be at the index pulse to either to the left or the right of the point where the home switch changes state. If the initial position is situated so that the direction of movement shall reverse during homing, the point at which the reversal takes place is anywhere after a change of state of the home switch.

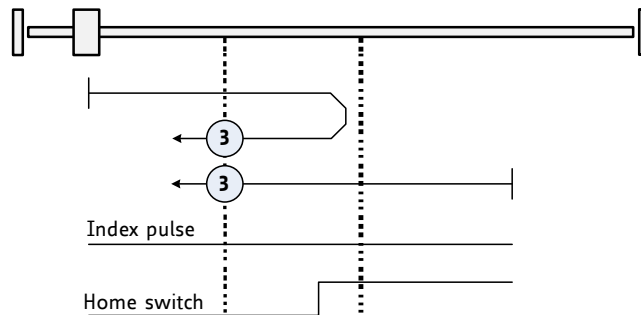

Figure 13: Homing Method 3

8.1.4 Homing Method 5: Homing on negative Home Switch and Index Pulse

Using this method, the initial direction of movement shall be dependent on the state of the home switch. The home position shall be at the index pulse to either to the left or the right of the point where the home switch changes state. If the initial position is situated so that the direction of movement shall reverse during homing, the point at which the reversal takes place is anywhere after a change of state of the home switch.



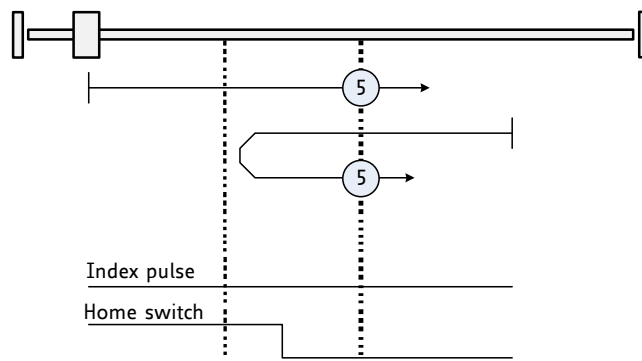

Figure 14: Homing Method 5

8.1.5 Homing Method 17: Homing on negative Limit Switch

Using this method, the initial direction of movement shall be leftward if the negative limit switch is inactive (here: low). The home position shall be at the point where the negative limit switch becomes inactive.

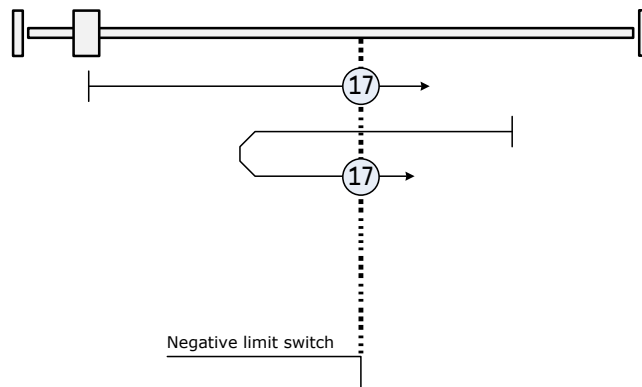

Figure 15: Homing Method 17

8.1.6 Homing Method 18: Homing on positive Limit Switch

Using this method, the initial direction of movement shall be rightward if the positive limit switch is inactive (here: low). The home position shall be at point the where the positive limit switch becomes inactive.

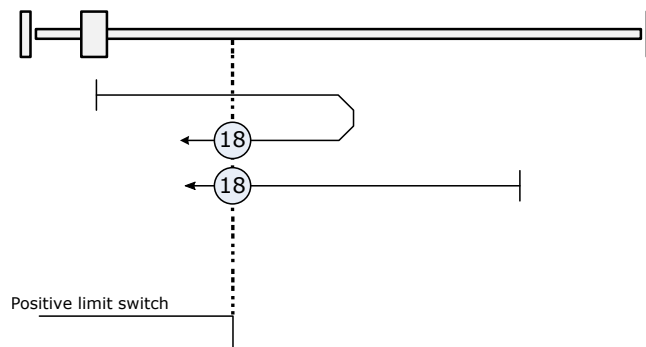

Figure 16: Homing Method 18



8.1.7 Homing Method 19: Homing on positive Home Switch

Using this method, the initial direction of movement shall be dependent on the state of the home switch. The home position shall be at the point where the home switch changes state. If the initial direction of movement leads away from the home switch, the drive shall reverse on encountering the relevant limit switch.

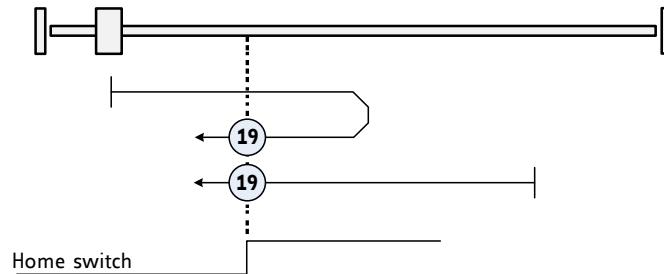

Figure 17: Homing Method 19

8.1.8 Homing Method 21: Homing on negative Home Switch

Using this method, the initial direction of movement shall be dependent on the state of the home switch. The home position shall be at the point where the home switch changes state. If the initial direction of movement leads away from the home switch, the drive shall reverse on encountering the relevant limit switch.

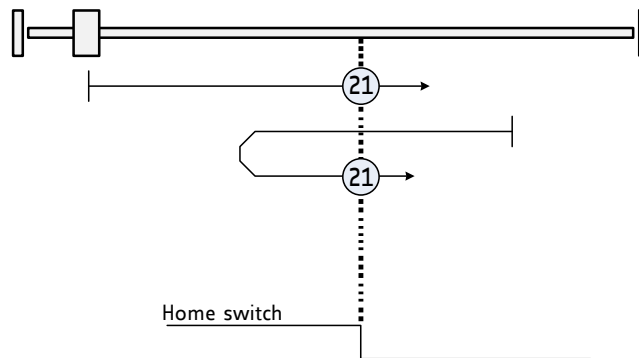

Figure 18: Homing Method 21

8.1.9 Homing Method 33 and 34: Homing on next Index Pulse

Using these methods, the direction of homing is negative or positive respectively. The home position shall be at the index pulse found in the selected direction.



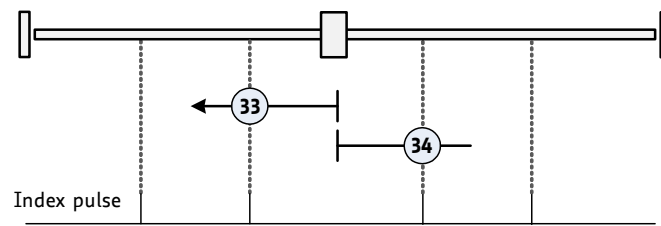

Figure 19: Homing Methods 33 and 34

8.1.10 Homing Method 35: Current Position as Home Position

In this method, the current position shall be taken to be the home position. This method does not require the drive device to be in operation enabled state.



8.2 Detailed Object Specifications

8.2.1 Object 6040_h: Control Word

This object indicates the received command controlling the power drive system finite state automaton (PDS FSA). The CiA-402 state machine can be controlled using this object. Please refer to figure 9 for detailed information.

Structure of the Control Word											
15	11	10	9	8	7	6	4	3	2	1	0
nu	r	oms	h	fr	oms	eo	qs	ev	so		
MSB						LSB					

Legend: nu=not used; r=reserved; oms=operation mode specific; h=halt; fr=fault reset; eo=enable operation; qs=quick stop; ev=enable voltage; so=switch on.

Table 287: Structure of the Control Word in hm Mode

Operation Mode specific Bits in hm Mode		
Bit	Name	Definition
4	Homing operation start	1: start homing; 0: stop homing
8	Halt	Not supported.

Table 288: Operation Mode specific Bits in hm Mode

Command Coding						
Command	Bits of Control Word					Transitions
	Bit 7	Bit 3	Bit 2	Bit 1	Bit 0	
Shutdown	0	x	1	1	0	2,6,8
Switch on	0	0	1	1	1	3
Switch on & enable operation	0	1	1	1	1	3, 4
Disable voltage	0	x	x	0	x	7,9,10,12
Quick stop	0	x	0	1	x	7,10,11
Disable operation	0	0	1	1	1	5
Enable operation	0	1	1	1	1	4, 16
Fault reset	0-to-1	x	x	x	x	15

Table 289: Command Coding



Object Description			
Index	Name	Object Type	Data Type
6040 _h	Controlword	Variable	UNSIGNED16

Table 290: Object Description (6040_h in hm Mode)

Entry Description				
Sub-index	Access	PDO Mapping	Value Range	Default Value
0	rw	see CiA402-3	See command coding above.	

Table 291: Entry Description (6040_h in hm Mode)

8.2.2 Object 6041_h: Status Word

This object provides the status of the PDS FSA. It reflects the status of the CiA-402 state machine. Please refer to figure 9 for detailed information. The object is structured as defined below.

For more information about the coding please refer to the CANopen Drives and motion control device profile, part 2.

Structure of the Status Word															
15	14	13	12	11	10	9	8	7	6	5	4	3	2	1	0
dir	mot	oms	ila	tr	rm	ms	w	sod	qs	ve	f	oe	so	rtso	
MSB														LSB	

Legend: nu=not used; r=reserved; oms=operation mode specific; h=halt; fr=fault reset; oe=operation enable; qs=quick stop; ve=voltage enable; so=switch on.

Table 292: Structure of the Status Word in hm Mode

Trinamic Specific Bits		
Bit	Name	Definition
14	Motor activity	0: Motor stands still. 1: Motor rotates.
15	Direction of rotation	This bit shows the direction of rotation.

Table 293: Trinamic Specific Bits



Operation Mode specific Bits in hm Mode		
Bit	Name	Definition
10	Target reached	Set when the zero position has been found or homing has been stopped by setting controlword bit 4 to zero.
12	Home attained	Set when zero position has been found.
13	Homing error	Not supported.

Table 294: Operation Mode specific Bits in hm Mode

State Coding	
Status word	FSA state
xxxx xxxx x0xx 0000 _h	Not ready to switch on
xxxx xxxx x1xx 0000 _h	Switch on disabled
xxxx xxxx x01x 0001 _h	Ready to switch on
xxxx xxxx x01x 0011 _h	Switched on
xxxx xxxx x01x 0111 _h	Operation enabled
xxxx xxxx x00x 0111 _h	Quick stop active
xxxx xxxx x0xx 1111 _h	Fault reaction active
xxxx xxxx x0xx 1000 _h	Fault

Table 295: State Coding

Object Description			
Index	Name	Object Type	Data Type
6041 _h	Controlword	Variable	UNSIGNED16

Table 296: Object Description (6041_h in hm Mode)

Entry Description				
Sub-index	Access	PDO Mapping	Value Range	Default Value
0	rw	see CiA402-3	See state coding above.	

Table 297: Entry Description (6041_h in hm Mode)

8.2.3 Object 606C_h: Velocity Actual Value

This object shows the actual velocity value of the motor. The value is given in internal or user-defined velocity units (depending on object 208C_h, described in section 4.2.17).



Object Description			
Index	Name	Object Type	Data Type
606C _h	Velocity Actual Value	Variable	SIGNED32

Table 298: Object Description (606C_h)

Entry Description				
Sub-index	Access	PDO Mapping	Value Range	Default Value
0	ro	Refer to CiA402-3	SIGNED32	no

Table 299: Entry Description (606C_h)

8.2.4 Object 607C_h: Home Offset

This object indicates the configured difference between the zero position for the application and the machine home position/home switch (found during homing). While homing, the machine home position is found and once the homing is completed, the zero position is offset from the home position by adding the home offset to the home position. The effect of setting the home position to a non-zero value depends on the selected homing method. The value of this object is given in microsteps. Negative values indicate the opposite direction.

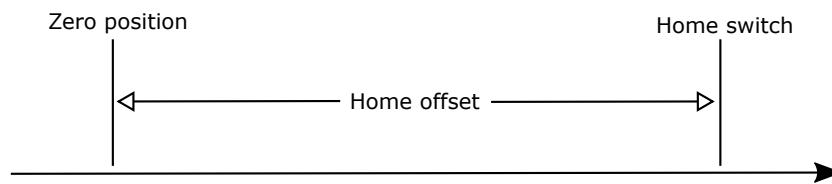

Figure 20: Home Offset

Object Description			
Index	Name	Object Type	Data Type
607C _h	Home offset	Variable	SIGNED32

Table 300: Object Description (607C_h)

Entry Description				
Sub-index	Access	PDO Mapping	Value Range	Default Value
0	rw	no	SIGNED32	0

Table 301: Entry Description (607C_h)



8.2.5 Object 6098_h: Homing Method

The homing method to be used can be selected by writing to this object. Please see table 286 for a list of homing methods supported by the current version of the TMCM-3212 CANopen firmware.

Object Description			
Index	Name	Object Type	Data Type
6098 _h	Homing method	Variable	SIGNED8

Table 302: Object Description (6098_h)

Entry Description				
Sub-index	Access	PDO Mapping	Value Range	Default Value
0	rw	no	SIGNED8	0

Table 303: Entry Description (6098_h)

8.2.6 Object 6099_h: Homing Speeds

This object indicates the configured speeds used during homing procedure. The values are given in pps units or internal units selectable with object 208C_h (section 4.2.17). Using object 6099_h a fast and a slow homing speed can be set. In most homing modes, the home switch is searched with the fast speed first. When the home switch has been found, the motor will be decelerated to the slow speed (using the homing acceleration, object 609A_h) to search for the exact switch point. When the switch point has been found the motor will be stopped at that point.

Object Description			
Index	Name	Object Type	Data Type
6099 _h	Homing speeds	Array	UNSIGNED32

Table 304: Object Description (6099_h)

Entry Description					
Sub-index	Description	Access	PDO Mapping	Value Range	Default Value
1	Fast homing speed	rw	no	UNSIGNED32	0
2	Slow homing speed	rw	no	UNSIGNED32	0

Table 305: Entry Description (6099_h)

8.2.7 Object 609A_h: Homing Acceleration

This object indicates the configured acceleration and deceleration to be used during homing operation. The value is given in units selected by object 208E_h (section 4.2.18).



Object Description			
Index	Name	Object Type	Data Type
609A _h	Homing acceleration	Variable	UNSIGNED32

Table 306: Object Description (609A_h)

Entry Description				
Sub-index	Access	PDO Mapping	Value Range	Default Value
0	rw	no	UNSIGNED32	0

Table 307: Entry Description (609A_h)

8.3 How to start a Homing in hm Mode

Here is a little example that shows how to home the motor in hm mode. In this little example we assume that the module has been reset (and then switched to pre-operational or operational) by NMT commands before. The home switch must be connected to the home switch input. It can be operated manually.

- Select hm mode by writing 6 to object 6060_h.
- Write 6 to object 6040_h to switch to READY_TO_SWITCH_ON state.
- Write 7 to object 6040_h to switch to SWITCHED_ON state.
- Write 15 to object 6040_h to switch to OPERATION_ENABLED state.
- Select homing method 19 by writing 19 to object 6098_h.
- Set the homing speeds by writing e.g. 50000 to object 6099_h sub index 1 and e.g. 10000 to object 6099_h sub index 2.
- Write 31 to object 6040_h to start the homing process.
- Press and release the home switch.
- When homing has finished, write 15 to object 6040_h again.



9 Cyclic synchronous Position Mode

The cyclic synchronous position mode is used to directly control the position of the motor. It contains limit functions, but not a trajectory generator. The trajectory generator is located in the control device (the master), not in the drive device. In cyclic synchronous manner, the control device provides a target position to the drive device, which performs position control, velocity control and torque control.

The main control parameters are the target position (object 607A_h, see section 9.1.7) and the interpolation time period (object 60C2_h, see section 9.1.10). The drive automatically sets the velocity in such a manner that the next target position is reached within the interpolation time period. Acceleration and deceleration ramps are not used in this mode.

The cyclic synchronous position mode covers the following sub-functions:

- Position demand value input directly via an object.
- Monitoring of the position.
- Limiting the position using the software limits or the hardware limit switches.

9.1 Detailed Object Specifications

9.1.1 Object 6040_h: Control Word

This object indicates the received command controlling the power drive system finite state automaton (PDS FSA). The CiA-402 state machine can be controlled using this object. Please refer to figure 9 for detailed information. The cyclic synchronous position mode does not use any mode specific bits of the control word.

Structure of the Control Word									
15	9	8	7	6	4	3	2	1	0
nu	h	fr	nu	eo	qs	ev	so		
MSB					LSB				

Legend: nu=not used; h=halt; fr=fault reset; eo=enable operation; qs=quick stop; ev=enable voltage; so=switch on.

Table 308: Structure of the Control Word in csp Mode



Command Coding						
Command	Bits of Control Word					Transitions
	Bit 7	Bit 3	Bit 2	Bit 1	Bit 0	
Shutdown	0	x	1	1	0	2,6,8
Switch on	0	0	1	1	1	3
Switch on & enable operation	0	1	1	1	1	3, 4
Disable voltage	0	x	x	0	x	7,9,10,12
Quick stop	0	x	0	1	x	7,10,11
Disable operation	0	0	1	1	1	5
Enable operation	0	1	1	1	1	4, 16
Fault reset	0-to-1	x	x	x	x	15

Table 309: Command Coding

Object Description			
Index	Name	Object Type	Data Type
6040 _h	Controlword	Variable	UNSIGNED16

Table 310: Object Description (6040_h in csp Mode)

Entry Description				
Sub-index	Access	PDO Mapping	Value Range	Default Value
0	rw	see CiA402-3	See command coding above.	

Table 311: Entry Description (6040_h in csp Mode)

9.1.2 Object 6041_h: Status Word

This object provides the status of the PDS FSA. It reflects the status of the CiA-402 state machine. Please refer to figure 9 for detailed information. The object is structured as defined below. For more information about the coding please refer to the CANopen Drives and motion control device profile, part 2.

Structure of the Status Word															
15	14	13	12	11	10	9	8	7	6	5	4	3	2	1	0
dir	mot	oms	ila	r	rm	ms	w	sod	qs	ve	f	oe	so	rtso	
MSB														LSB	

Legend: nu=not used; r=reserved; oms=operation mode specific; h=halt; fr=fault reset; oe=operation enable; qs=quick stop; ve=voltage enable; so=switch on.

Table 312: Structure of the Status Word in csp Mode



Trinamic Specific Bits		
Bit	Name	Definition
14	Motor activity	0: Motor stands still. 1: Motor rotates.
15	Direction of rotation	This bit shows the direction of rotation.

Table 313: Trinamic Specific Bits

Operation Mode specific Bits in csp Mode		
Bit	Name	Definition
10	Reserved	Not used.
12	Target position ignored	0: Target position ignored. 1: Target position used as input to position controller.
13	Following error	0: No following error. 1: Following error.

Table 314: Operation Mode specific Bits in csp Mode

State Coding	
Status word	FSA state
xxxx xxxx x0xx 0000 _h	Not ready to switch on
xxxx xxxx x1xx 0000 _h	Switch on disabled
xxxx xxxx x01x 0001 _h	Ready to switch on
xxxx xxxx x01x 0011 _h	Switched on
xxxx xxxx x01x 0111 _h	Operation enabled
xxxx xxxx x00x 0111 _h	Quick stop active
xxxx xxxx x0xx 1111 _h	Fault reaction active
xxxx xxxx x0xx 1000 _h	Fault

Table 315: State Coding

Object Description			
Index	Name	Object Type	Data Type
6041 _h	Controlword	Variable	UNSIGNED16

Table 316: Object Description (6041_h in csp Mode)



Entry Description				
Sub-index	Access	PDO Mapping	Value Range	Default Value
0	rw	see CiA402-3	See state coding above	

Table 317: Entry Description (6041_h in csp Mode)

9.1.3 Object 6062_h: Position Demand Value

This object provides the demanded position value. The value is given in microsteps. Object 6062_h indicates the actual position that the motor should have. It is not to be confused with objects 6063_h and 6064_h.

Object Description			
Index	Name	Object Type	Data Type
6062 _h	Position Demand Value	Variable	SIGNED32

Table 318: Object Description (6062_h)

Entry Description				
Sub-index	Access	PDO Mapping	Value Range	Default Value
0	ro	Refer to CiA402-3	SIGNED32	no

Table 319: Entry Description (6062_h)

9.1.4 Object 6063_h: Position Actual Internal Value

This object provides the actual value of the encoder or the motor. Please use the sensor selection object 606A_h (see section 5.1.8) for selecting the motor or the encoder first. Object 6063_h indicates the actual position of the encoder or the motor, re-scaled to the microstep resolution. The value is given in microsteps.

Object Description			
Index	Name	Object Type	Data Type
6063 _h	Position Actual Internal Value	Variable	SIGNED32

Table 320: Object Description (6063_h)

Entry Description				
Sub-index	Access	PDO Mapping	Value Range	Default Value
0	ro	Refer to CiA402-3	SIGNED32	no

Table 321: Entry Description (6063_h)

9.1.5 Object 6064_h: Position Actual Value

This object provides the actual value of the position measurement device. It always contains the same value as object 6063_h.

Object Description			
Index	Name	Object Type	Data Type
6064 _h	Position Actual Value	Variable	SIGNED32

Table 322: Object Description (6064_h)

Entry Description				
Sub-index	Access	PDO Mapping	Value Range	Default Value
0	ro	Refer to CiA402-3	SIGNED32	no

Table 323: Entry Description (6064_h)

9.1.6 Object 606C_h: Velocity Actual Value

This object shows the actual velocity value of the motor. The value is given in internal or user-defined velocity units (depending on object 208C_h, described in section 4.2.17).

Object Description			
Index	Name	Object Type	Data Type
606C _h	Velocity Actual Value	Variable	SIGNED32

Table 324: Object Description (606C_h)

Entry Description				
Sub-index	Access	PDO Mapping	Value Range	Default Value
0	ro	Refer to CiA402-3	SIGNED32	no

Table 325: Entry Description (606C_h)

9.1.7 Object 607A_h: Target Position

The target position is the position that the drive should move to in cyclic synchronous position mode using the current interpolation time period. In csp mode this value is always interpreted as an absolute value.

Object Description			
Index	Name	Object Type	Data Type
607A _h	Target Position	Variable	SIGNED32

Table 326: Object Description (607A_h in csp Mode)



Entry Description				
Sub-index	Access	PDO Mapping	Value Range	Default Value
0	rw	Refer to CiA402-3	SIGNED32	0

Table 327: Entry Description (607A_h in csp Mode)

9.1.8 Object 607D_h: Software Position Limit

This object indicates the configured maximal and minimal software position limits. These parameters define the absolute position limits for the position demand value and the position actual value. Every new target position is checked against these limits. The limit positions are always relative to the machine home position. Before being compared with the target position, they are corrected internally by the home offset as follows:

$$\text{Corrected_min_position_limit} = \text{min_position_limit} - \text{home_offset}$$

$$\text{Corrected_max_position_limit} = \text{max_position_limit} - \text{home_offset}$$

Object Description			
Index	Name	Object Type	Data Type
607D _h	Software Position Limit	Array	SIGNED32

Table 328: Object Description (607D_h)

Entry Description					
Sub-index	Description	Access	PDO Mapping	Value Range	Default Value
1	Minimum Position Limit	rw	no	SIGNED32	-2147483648
2	Maximum Position Limit	rw	no	SIGNED32	2147483647

Table 329: Entry Description (607D_h)

9.1.9 Object 60B0_h: Position Offset

This object provides an offset to the target position (object 607A_h, see section 9.1.7). The value is given in microsteps and will be added to the target position.

Object Description			
Index	Name	Object Type	Data Type
60B0 _h	Offset Torque	Variable	INTEGER32

Table 330: Object Description (60B0_h)

Entry Description				
Sub-index	Access	PDO Mapping	Value Range	Default Value
0	rw	yes	-2147483648...2147483647	0

Table 331: Entry Description (60B0_h)

9.1.10 Object 60C2_h: Interpolation Time Period

This object indicates the interpolation cycle time. The interpolation time period (sub-index 01_h) is given in $10^{\text{interpolation_time_index}}$ s. The interpolation time index (sub-index 02_h) is dimensionless.

Object Description			
Index	Name	Object Type	Data Type
60C2 _h	Offset Torque	Vecord	Interpolation time period record (0080 _h)

Table 332: Object Description (60C2_h)

Entry Description					
Sub-index	Description	Access	PDO Mapping	Value Range	Default Value
0	Highest sub-index supported	ro	no	UNSIGNED8	2
1	Interpolation time period value	rw	no	UNSIGNED8	1
2	Interpolation time index	rw	no	-3...3	-3

Table 333: Entry Description (60C2_h)

10 Cyclic synchronous Velocity Mode

The cyclic synchronous velocity mode is used to directly control the velocity of the motor. It contains limit functions, but not a trajectory generator. The trajectory generator is located in the control device (the master), not in the drive device. In cyclic synchronous manner, the control device provides a target velocity to the drive device, which performs position control, velocity control and torque control.

The main control parameters are the target velocity (object 60FF_h, see section 10.1.4) and the interpolation time period (object 60C2_h, see section 10.1.7). The drive automatically sets the acceleration in such a manner that the next target velocity is reached within the interpolation time period. Acceleration and deceleration ramps are not used in this mode.

The cyclic synchronous velocity mode covers the following sub-functions:

- Velocity demand value input directly via an object.
- Monitoring of the position.
- Limiting the position using the software limits or the hardware limit switches.

10.1 Detailed Object Specifications

10.1.1 Object 6040_h: Control Word

This object indicates the received command controlling the power drive system finite state automaton (PDS FSA). The CiA-402 state machine can be controlled using this object. Please refer to figure 9 for detailed information. The cyclic synchronous velocity mode does not use any mode specific bits of the control word.

Structure of the Control Word									
15	9	8	7	6	4	3	2	1	0
nu	h	fr	nu	eo	qs	ev	so		
MSB					LSB				

Legend: nu=not used; h=halt; fr=fault reset; eo=enable operation; qs=quick stop; ev=enable voltage; so=switch on.

Table 334: Structure of the Control Word in csv Mode



Command Coding						
Command	Bits of Control Word					Transitions
	Bit 7	Bit 3	Bit 2	Bit 1	Bit 0	
Shutdown	0	x	1	1	0	2,6,8
Switch on	0	0	1	1	1	3
Switch on & enable operation	0	1	1	1	1	3, 4
Disable voltage	0	x	x	0	x	7,9,10,12
Quick stop	0	x	0	1	x	7,10,11
Disable operation	0	0	1	1	1	5
Enable operation	0	1	1	1	1	4, 16
Fault reset	0-to-1	x	x	x	x	15

Table 335: Command Coding

Object Description			
Index	Name	Object Type	Data Type
6040 _h	Controlword	Variable	UNSIGNED16

Table 336: Object Description (6040_h in csv Mode)

Entry Description				
Sub-index	Access	PDO Mapping	Value Range	Default Value
0	rw	see CiA402-3	See command coding above.	

Table 337: Entry Description (6040_h in csv Mode)

10.1.2 Object 6041_h: Status Word

This object provides the status of the PDS FSA. It reflects the status of the CiA-402 state machine. Please refer to figure 9 for detailed information. The object is structured as defined below. For more information about the coding please refer to the CANopen Drives and motion control device profile, part 2.

Structure of the Status Word															
15	14	13	12	11	10	9	8	7	6	5	4	3	2	1	0
dir	mot	oms	ila	r	rm	ms	w	sod	qs	ve	f	oe	so	rtso	
MSB														LSB	

Legend: nu=not used; r=reserved; oms=operation mode specific; h=halt; fr=fault reset; oe=operation enable; qs=quick stop; ve=voltage enable; so=switch on.

Table 338: Structure of the Status Word in csv Mode



Trinamic Specific Bits		
Bit	Name	Definition
14	Motor activity	0: Motor stands still. 1: Motor rotates.
15	Direction of rotation	This bit shows the direction of rotation.

Table 339: Trinamic Specific Bits

Operation Mode specific Bits in csv Mode		
Bit	Name	Definition
10	Reserved	Not used.
12	Target position ignored	0: Target velocity ignored. 1: Target velocity used as input to velocity controller.
13	Reserved	Not used.

Table 340: Operation Mode specific Bits in csv Mode

State Coding	
Status word	FSA state
xxxx xxxx x0xx 0000 _h	Not ready to switch on
xxxx xxxx x1xx 0000 _h	Switch on disabled
xxxx xxxx x01x 0001 _h	Ready to switch on
xxxx xxxx x01x 0011 _h	Switched on
xxxx xxxx x01x 0111 _h	Operation enabled
xxxx xxxx x00x 0111 _h	Quick stop active
xxxx xxxx x0xx 1111 _h	Fault reaction active
xxxx xxxx x0xx 1000 _h	Fault

Table 341: State Coding

Object Description			
Index	Name	Object Type	Data Type
6041 _h	Controlword	Variable	UNSIGNED16

Table 342: Object Description (6041_h in csv Mode)

Entry Description				
Sub-index	Access	PDO Mapping	Value Range	Default Value
0	rw	see CiA402-3	See state coding above	

Table 343: Entry Description (6041_h in csv Mode)

10.1.3 Object 606C_h: Velocity Actual Value

This object shows the actual velocity value of the motor. The value is given in internal or user-defined velocity units (depending on object 208C_h, described in section 4.2.17).

Object Description			
Index	Name	Object Type	Data Type
606C _h	Velocity Actual Value	Variable	SIGNED32

Table 344: Object Description (606C_h)

Entry Description				
Sub-index	Access	PDO Mapping	Value Range	Default Value
0	ro	Refer to CiA402-3	SIGNED32	no

Table 345: Entry Description (606C_h)

10.1.4 Object 60FF_h: Target Velocity

In csv mode the target velocity specifies the velocity that is to be reached within the interpolation time period. The values are given in units which can be selected with object 208C_h, described in section 4.2.17.

Object Description			
Index	Name	Object Type	Data Type
60FF _h	Target Velocity	Variable	SIGNED32

Table 346: Object Description (60FF_h)

Entry Description				
Sub-index	Access	PDO Mapping	Value Range	Default Value
0	rw	see CiA402-3	SIGNED32	0

Table 347: Entry Description (60FF_h)

10.1.5 Object 607D_h: Software Position Limit

This object indicates the configured maximal and minimal software position limits. These parameters define the absolute position limits for the position demand value and the position actual value. Every new



target position is checked against these limits. The limit positions are always relative to the machine home position. Before being compared with the target position, they are corrected internally by the home offset as follows:

$$\begin{aligned} \text{Corrected_min_position_limit} &= \text{min_position_limit} - \text{home_offset} \\ \text{Corrected_max_position_limit} &= \text{max_position_limit} - \text{home_offset} \end{aligned}$$

Object Description			
Index	Name	Object Type	Data Type
607D _h	Software Position Limit	Array	SIGNED32

Table 348: Object Description (607D_h)

Entry Description					
Sub-index	Description	Access	PDO Mapping	Value Range	Default Value
1	Minimum Position Limit	rw	no	SIGNED32	-2147483648
2	Maximum Position Limit	rw	no	SIGNED32	2147483647

Table 349: Entry Description (607D_h)

10.1.6 Object 60B1_h: Velocity Offset

This object provides an offset to the target velocity (object 60FF_h, see section 10.1.4). The value will be added to the target velocity.

Object Description			
Index	Name	Object Type	Data Type
60B1 _h	Velocity Offset	Variable	INTEGER32

Table 350: Object Description (60B1_h)

Entry Description				
Sub-index	Access	PDO Mapping	Value Range	Default Value
0	rw	yes	-2147483648...2147483647	0

Table 351: Entry Description (60B1_h)

10.1.7 Object 60C2_h: Interpolation Time Period

This object indicates the interpolation cycle time. The interpolation time period (sub-index 01_h) is given in $10^{\text{interpolation_time_index}}$ s. The interpolation time index (sub-index 02_h) is dimensionless.



Object Description			
Index	Name	Object Type	Data Type
60C2 _h	Offset Torque	Vecord	Interpolation time period record (0080 _h)

Table 352: Object Description (60C2_h)

Entry Description					
Sub-index	Description	Access	PDO Mapping	Value Range	Default Value
0	Highest sub-index supported	ro	no	UNSIGNED8	2
1	Interpolation time period value	rw	no	UNSIGNED8	1
2	Interpolation time index	rw	no	-3...3	-3

Table 353: Entry Description (60C2_h)



11 Emergency Messages (EMCY)

The module sends an emergency message if an error occurs. The message contains information about the error type. The module can map internal errors and object 1001_h (error register) is part of every emergency object.

Please note that the additional byte #2 shows which motor is affected.

Emergency Messages (EMCY) of the TMCM-3212						
Error code	Additional byte					Description
	1	2	3	4	5	
0000 _h	0	0...2	0	0	0	Fault reset The fault reset command has been executed.
1000 _h	1	0...2	0	0	0	Generic error: open load bridge A The motor driver indicates open load on bridge A. It is possible that the motor cable is broken or that there is an error in the power amplifier itself.
1000 _h	2	0...2	0	0	0	Generic error: open load bridge B The motor driver indicates open load on bridge B. It is possible that the motor cable is broken or that there is an error in the power amplifier itself.
2310 _h	0	0...2	0	0	0	Overcurrent high side The motor driver indicates an overcurrent on the high side. This can be caused by a short circuit in the driver stage.
2311 _h	0	0...2	0	0	0	Overcurrent bridge B The motor driver indicates that there is overcurrent on bridge B. This can be caused by a short circuit in the motor itself or in the motor driver stage.
2312 _h	0	0...2	0	0	0	Overcurrent bridge A The motor driver indicates that there is overcurrent on bridge A. This can be caused by a short circuit in the motor itself or in the motor driver stage.
3230 _h	0	0...2	0	0	0	stallGuard2 error The actual load value exceeds the stallGuard2 limit.
4310 _h	1	0...2	0	0	0	Overtemperature pre-warning The temperature in the motor driver exceeds the pre-warning limit.
4310 _h	2	0...2	0	0	0	Overtemperature error The motor driver has been switched off because the temperature limit has been exceeded.
5441 _h	0	255	0	0	0	Shutdown switch active The enable signal is missing (due to the shutdown switch) and the motor driver has been switched off.
6320 _h	0	255	0	0	0	Parameter error The data in the received PDO is either wrong or cannot be accepted due to the internal state of the drive.



Error code	Additional byte					Description
	1	2	3	4	5	
8110 _h	1	255	0	0	0	CAN controller overflow The receive message buffer of the CAN controller hardware is full and some CAN messages are lost.
8110 _h	2	255	0	0	0	CAN Tx buffer overflow The software CAN transmit buffer is full and thus some CAN messages are lost.
8110 _h	3	255	0	0	0	CAN Rx buffer overflow The software CAN receive buffer is full and so some CAN messages are lost.
8120 _h	0	255	0	0	0	CAN error passive The CAN controller has detected communication errors and has entered the CAN Error passive state.
8140 _h	0	255	0	0	0	CAN controller recovered from bus-off state The CAN controller has detected too many errors and has changed into the bus-off state. The drive has been stopped and disabled. This message is sent after the CAN controller has recovered from bus-off state and is bus-on again.
8611 _h	0	0...2	0	0	0	Following error The deviation between motor position counter and encoder position counter has exceeded the following error window.
ff00 _h	0	0...2	0	0	0	Undervoltage The supply voltage is too low to drive a motor.
ff01 _h	1	0...2	0	0	0	Positive software limit The actual position is outside the range defined by object 607d _h .
ff01 _h	2	0...2	0	0	0	Negative software limit The actual position is outside the range defined by object 607d _h .
ff01 _h	3	0...2	0	0	0	Positive limit switch The positive limit switch has been touched outside of the homing function.
ff01 _h	4	0...2	0	0	0	Negative limit switch The negative limit switch has been touched outside of the homing function.

Table 354: Emergency Messages (EMCY)



12 Figures Index

1	StallGuard2 Load Measurement as a Function of Load	9	10	Homing Mode Function	95
2	Energy Efficiency Example with CoolStep	10	11	Homing Method 1	96
3	Typical motion profile with TRINAMIC's SixPoint™ motion controller	10	12	Homing Method 2	97
4	NMT State Machine	14	13	Homing Method 3	97
5	Communication Architecture	15	14	Homing Method 5	98
6	Device Model	16	15	Homing Method 17	98
7	CoolStep Adjustment Points and Thresholds	34	16	Homing Method 18	98
8	Brake Output Timing	37	17	Homing Method 19	99
9	DS402 Finite State Machine	75	18	Homing Method 21	99
			19	Homing Methods 33 and 34	100
			20	Home Offset	104



13 Tables Index

1	Abbreviations used in this Manual . . .	8	53	Entry Description (1A00 _h)	32
2	SixPoint Ramp Parameters	11	54	Multi-axis Object Indices (Manufacturer specific Area)	33
3	Service Primitives	12	55	CoolStep related Objects	35
4	Service Types	13	56	Object Description (2000 _h)	36
5	Object Dictionary	16	57	Entry Description (2000 _h)	36
6	Multi-Axis Object Indices	17	58	Object Description (2001 _h)	36
7	Object Description (1000 _h)	18	59	Entry Description (2001 _h)	36
8	Entry Description (1000 _h)	18	60	Object Description (2002 _h)	37
9	Object Description (1001 _h)	18	61	Entry Description (2002 _h)	37
10	Entry Description (1001 _h)	18	62	Object Description (2003 _h)	37
11	Error Register Bits	19	63	Entry Description (2003 _h)	37
12	Value Definition (1005 _h)	19	64	Object Description (2004 _h)	38
13	Object Description (1005 _h)	19	65	Entry Description (2004 _h)	38
14	Entry Description (1005 _h)	19	66	Object Description (2005 _h)	38
15	Object Description (1008 _h)	20	67	Entry Description (2005 _h)	38
16	Entry Description (1008 _h)	20	68	Bit Definitions (2005 _h)	39
17	Object Description (1009 _h)	20	69	Object Description (200A _h)	39
18	Entry Description (1009 _h)	20	70	Entry Description (200A _h)	39
19	Object Description (100A _h)	20	71	Object Description (200B _h)	39
20	Entry Description (100A _h)	21	72	Entry Description (200B _h)	40
21	Object Description (100C _h)	21	73	Object Description (200C _h)	40
22	Entry Description (100C _h)	21	74	Entry Description (200C _h)	40
23	Object Description (100D _h)	21	75	Object Description (200F _h)	40
24	Entry Description (100D _h)	21	76	Entry Description (200F _h)	41
25	Save Signature	22	77	Object Description (2010 _h)	41
26	Object Description (1010 _h)	22	78	Entry Description (2010 _h)	41
27	Entry Description (1010 _h)	23	79	Object Description (2011 _h)	41
28	Load Signature	23	80	Entry Description (2011 _h)	41
29	Object Description (1011 _h)	24	81	Object Description (2012 _h)	42
30	Entry Description (1011 _h)	24	82	Entry Description (2012 _h)	42
31	Object Description (1014 _h)	24	83	Object Description (2013 _h)	42
32	Entry Description (1014 _h)	24	84	Entry Description (2013 _h)	42
33	Object Description (1015 _h)	25	85	Object Description (2015 _h)	43
34	Entry Description (1015 _h)	25	86	Entry Description (2015 _h)	43
35	Value Definition (1016 _h)	25	87	Object Description (2089 _h)	43
36	Object Description (1016 _h)	25	88	Entry Description (2089 _h)	43
37	Entry Description (1016 _h)	25	89	Object Description (208C _h)	44
38	Object Description (1017 _h)	26	90	Entry Description (208C _h)	44
39	Entry Description (1017 _h)	26	91	Object Description (208E _h)	44
40	Object Description (1018 _h)	26	92	Entry Description (208E _h)	44
41	Entry Description (1018 _h)	26	93	Object Description (2092 _h)	44
42	Object Description (1023 _h)	27	94	Entry Description (2092 _h)	45
43	Entry Description (1023 _h)	27	95	Object Description (2093 _h)	45
44	Object Description (1029 _h)	27	96	Entry Description (2093 _h)	45
45	Entry Description (1029 _h)	27	97	Object Description (2094 _h)	45
46	Object Description (1400 _h)	28	98	Entry Description (2094 _h)	45
47	Entry Description (1400 _h)	28	99	Object Description (2095 _h)	46
48	Object Description (1600 _h)	29	100	Entry Description (2095 _h)	46
49	Entry Description (1600 _h)	29	101	Object Description (2096 _h)	46
50	Object Description (1800 _h)	30	102	Entry Description (2096 _h)	46
51	Entry Description (1800 _h)	31	103	Object Description (2097 _h)	47
52	Object Description (1A00 _h)	31			



104	Entry Description (2097 _h)	47	158	Object Description (2121 _h)	59
105	Object Description (2098 _h)	47	159	Entry Description (2121 _h)	59
106	Entry Description (2098 _h)	47	160	Object Description (2122 _h)	59
107	Object Description (2099 _h)	48	161	Entry Description (2122 _h)	59
108	Entry Description (2099 _h)	48	162	Object Description (2700 _h)	60
109	Object Description (209A _h)	48	163	Entry Description (2700 _h)	60
110	Entry Description (209A _h)	48	164	Object Description (2701 _h)	60
111	Object Description (209B _h)	49	165	Entry Description (2701 _h)	60
112	Entry Description (209B _h)	49	166	Bit Definitions (2702 _h)	61
113	Object Description (209C _h)	49	167	Object Description (2702 _h)	61
114	Entry Description (209C _h)	49	168	Entry Description (2702 _h)	61
115	Object Description (209D _h)	50	169	Bit Definitions (2703 _h)	61
116	Entry Description (209D _h)	50	170	Object Description (2703 _h)	62
117	Object Description (209E _h)	50	171	Entry Description (2703 _h)	62
118	Entry Description (209E _h)	50	172	Object Description (2704 _h)	62
119	Object Description (20A1 _h)	50	173	Entry Description (2704 _h)	62
120	Entry Description (20A1 _h)	51	174	Object Description (2705 _h)	63
121	Object Description (20A3 _h)	51	175	Entry Description (2705 _h)	63
122	Entry Description (20A3 _h)	51	176	Object Description (2706 _h)	63
123	Object Description (20A4 _h)	51	177	Entry Description (2706 _h)	63
124	Entry Description (20A4 _h)	51	178	Object Description (2707 _h)	64
125	Object Description (20A5 _h)	52	179	Entry Description (2707 _h)	64
126	Entry Description (20A5 _h)	52	180	Object Description (2708 _h)	64
127	Object Description (20B0 _h)	52	181	Entry Description (2708 _h)	64
128	Entry Description (20B0 _h)	52	182	Object Description (270E _h)	64
129	Object Description (20B1 _h)	53	183	Entry Description (270E _h)	65
130	Entry Description (20B1 _h)	53	184	Multi-axis Object Indices (Profile specific Area)	66
131	Object Description (20B2 _h)	53	185	Value Description (605A _h)	67
132	Entry Description (20B2 _h)	53	186	Object Description (605A _h)	67
133	Object Description (20B3 _h)	53	187	Entry Description (605A _h)	67
134	Entry Description (20B3 _h)	54	188	Value Description (605B _h)	67
135	Object Description (20B4 _h)	54	189	Object Description (605B _h)	67
136	Entry Description (20B4 _h)	54	190	Entry Description (605B _h)	68
137	Object Description (20B5 _h)	54	191	Value Description (605C _h)	68
138	Entry Description (20B5 _h)	54	192	Object Description (605C _h)	68
139	Object Description (20B6 _h)	55	193	Entry Description (605C _h)	68
140	Entry Description (20B6 _h)	55	194	Value Description (605D _h)	68
141	Object Description (20B7 _h)	55	195	Object Description (605D _h)	69
142	Entry Description (20B7 _h)	55	196	Entry Description (605D _h)	69
143	Object Description (20B8 _h)	55	197	Value Description (605E _h)	69
144	Entry Description (20B8 _h)	56	198	Object Description (605E _h)	69
145	Object Description (20B9 _h)	56	199	Entry Description (605E _h)	69
146	Entry Description (20B9 _h)	56	200	Value Description (6060 _h)	70
147	Object Description (2100 _h)	56	201	Object Description (6060 _h)	70
148	Entry Description (2100 _h)	56	202	Entry Description (6060 _h)	70
149	Object Description (2101 _h)	57	203	Value Description (6061 _h)	71
150	Entry Description (2101 _h)	57	204	Object Description (6061 _h)	71
151	Driver Error Flags (2102 _h)	57	205	Entry Description (6061 _h)	71
152	Object Description (2102 _h)	57	206	Value Description (606A _h)	71
153	Entry Description (2102 _h)	58	207	Object Description (606A _h)	72
154	Object Description (2107 _h)	58	208	Entry Description (606A _h)	72
155	Entry Description (2107 _h)	58	209	Object Description (608F _h)	72
156	Object Description (210B _h)	58	210	Entry Description (608F _h)	72
157	Entry Description (210B _h)	58			



211	Object Description (60FD _h)	73	263	Trinamic Specific Bits	89
212	Entry Description (60FD _h)	73	264	Operation Mode specific Bits in pv Mode	89
213	Value Definition (6502 _h)	73	265	State Coding	89
214	Object Description (6502 _h)	73	266	Object Description (6041 _h in pv Mode)	89
215	Entry Description (6502 _h)	74	267	Entry Description (6041 _h in pv Mode)	90
216	Structure of the Control Word in pp Mode	76	268	Object Description (6062 _h)	90
217	Operation Mode specific Bits in pp Mode	76	269	Entry Description (6062 _h)	90
218	Command Coding	76	270	Object Description (6063 _h)	90
219	Object Description (6040 _h in pp Mode)	77	271	Entry Description (6063 _h)	90
220	Entry Description (6040 _h in pp Mode)	77	272	Object Description (6064 _h)	91
221	Structure of the Status Word in pp Mode	77	273	Entry Description (6064 _h)	91
222	Trinamic Specific Bits	77	274	Object Description (6065 _h)	91
223	Operation Mode specific Bits in pp Mode	78	275	Entry Description (6065 _h)	91
224	State Coding	78	276	Object Description (606C _h)	92
225	Object Description (6041 _h in pp Mode)	78	277	Entry Description (606C _h)	92
226	Entry Description (6041 _h in pp Mode)	78	278	Object Description (607D _h)	92
227	Object Description (6062 _h)	79	279	Entry Description (607D _h)	92
228	Entry Description (6062 _h)	79	280	Object Description (6083 _h)	93
229	Object Description (6063 _h)	79	281	Entry Description (6083 _h)	93
230	Entry Description (6063 _h)	79	282	Object Description (6085 _h)	93
231	Object Description (6064 _h)	79	283	Entry Description (6085 _h)	93
232	Entry Description (6064 _h)	80	284	Object Description (60FF _h)	94
233	Object Description (6065 _h)	80	285	Entry Description (60FF _h)	94
234	Entry Description (6065 _h)	80	286	Supported CANopen Homing Methods	96
235	Object Description (6067 _h)	81	287	Structure of the Control Word in hm Mode	101
236	Entry Description (6067 _h)	81	288	Operation Mode specific Bits in hm Mode	101
237	Object Description (6068 _h)	81	289	Command Coding	101
238	Entry Description (6068 _h)	81	290	Object Description (6040 _h in hm Mode)	102
239	Object Description (606C _h)	81	291	Entry Description (6040 _h in hm Mode)	102
240	Entry Description (606C _h)	82	292	Structure of the Status Word in hm Mode	102
241	Object Description (607A _h in pp Mode)	82	293	Trinamic Specific Bits	102
242	Entry Description (607A _h in pp Mode)	82	294	Operation Mode specific Bits in hm Mode	103
243	Object Description (607D _h)	82	295	State Coding	103
244	Entry Description (607D _h)	83	296	Object Description (6041 _h in hm Mode)	103
245	Object Description (6081 _h)	83	297	Entry Description (6041 _h in hm Mode)	103
246	Entry Description (6081 _h)	83	298	Object Description (606C _h)	104
247	Object Description (6082 _h)	83	299	Entry Description (606C _h)	104
248	Entry Description (6082 _h)	83	300	Object Description (607C _h)	104
249	Object Description (6083 _h)	84	301	Entry Description (607C _h)	104
250	Entry Description (6083 _h)	84	302	Object Description (6098 _h)	105
251	Object Description (6084 _h)	84	303	Entry Description (6098 _h)	105
252	Entry Description (6084 _h)	84	304	Object Description (6099 _h)	105
253	Object Description (6085 _h)	85	305	Entry Description (6099 _h)	105
254	Entry Description (6085 _h)	85	306	Object Description (609A _h)	106
255	Bit Definitions of Object 60F2 _h	85	307	Entry Description (609A _h)	106
256	Object Description (60F2 _h)	85	308	Structure of the Control Word in csp Mode	107
257	Entry Description (60F2 _h)	85	309	Command Coding	108
258	Structure of the Control Word in pv Mode	87	310	Object Description (6040 _h in csp Mode)	108
259	Command Coding	88	311	Entry Description (6040 _h in csp Mode)	108
260	Object Description (6040 _h in pv Mode)	88			
261	Entry Description (6040 _h in pv Mode)	88			
262	Structure of the Status Word in pv Mode	88			



312	Structure of the Status Word in csp Mode	108	334	Structure of the Control Word in csv Mode	114
313	Trinamic Specific Bits	109	335	Command Coding	115
314	Operation Mode specific Bits in csp Mode	109	336	Object Description (6040 _h in csv Mode)	115
315	State Coding	109	337	Entry Description (6040 _h in csv Mode)	115
316	Object Description (6041 _h in csp Mode)	109	338	Structure of the Status Word in csv Mode	115
317	Entry Description (6041 _h in csp Mode)	110	339	Trinamic Specific Bits	116
318	Object Description (6062 _h)	110	340	Operation Mode specific Bits in csv Mode	116
319	Entry Description (6062 _h)	110	341	State Coding	116
320	Object Description (6063 _h)	110	342	Object Description (6041 _h in csv Mode)	116
321	Entry Description (6063 _h)	110	343	Entry Description (6041 _h in csv Mode)	117
322	Object Description (6064 _h)	111	344	Object Description (606C _h)	117
323	Entry Description (6064 _h)	111	345	Entry Description (606C _h)	117
324	Object Description (606C _h)	111	346	Object Description (60FF _h)	117
325	Entry Description (606C _h)	111	347	Entry Description (60FF _h)	117
326	Object Description (607A _h in csp Mode)	111	348	Object Description (607D _h)	118
327	Entry Description (607A _h in csp Mode)	112	349	Entry Description (607D _h)	118
328	Object Description (607D _h)	112	350	Object Description (60B1 _h)	118
329	Entry Description (607D _h)	112	351	Entry Description (60B1 _h)	118
330	Object Description (60B0 _h)	112	352	Object Description (60C2 _h)	119
331	Entry Description (60B0 _h)	113	353	Entry Description (60C2 _h)	119
332	Object Description (60C2 _h)	113	354	Emergency Messages (EMCY)	121
333	Entry Description (60C2 _h)	113	355	Firmware Revision	129
			356	Document Revision	129



14 Supplemental Directives

14.1 Producer Information

14.2 Copyright

TRINAMIC owns the content of this user manual in its entirety, including but not limited to pictures, logos, trademarks, and resources. © Copyright 2019 TRINAMIC. All rights reserved. Electronically published by TRINAMIC, Germany.

Redistributions of source or derived format (for example, Portable Document Format or Hypertext Markup Language) must retain the above copyright notice, and the complete Datasheet User Manual documentation of this product including associated Application Notes; and a reference to other available product-related documentation.

14.3 Trademark Designations and Symbols

Trademark designations and symbols used in this documentation indicate that a product or feature is owned and registered as trademark and/or patent either by TRINAMIC or by other manufacturers, whose products are used or referred to in combination with TRINAMIC's products and TRINAMIC's product documentation.

This CANopen® Firmware Manual is a non-commercial publication that seeks to provide concise scientific and technical user information to the target user. Thus, trademark designations and symbols are only entered in the Short Spec of this document that introduces the product at a quick glance. The trademark designation /symbol is also entered when the product or feature name occurs for the first time in the document. All trademarks and brand names used are property of their respective owners.

14.4 Target User

The documentation provided here, is for programmers and engineers only, who are equipped with the necessary skills and have been trained to work with this type of product.

The Target User knows how to responsibly make use of this product without causing harm to himself or others, and without causing damage to systems or devices, in which the user incorporates the product.

14.5 Disclaimer: Life Support Systems

TRINAMIC Motion Control GmbH & Co. KG does not authorize or warrant any of its products for use in life support systems, without the specific written consent of TRINAMIC Motion Control GmbH & Co. KG.

Life support systems are equipment intended to support or sustain life, and whose failure to perform, when properly used in accordance with instructions provided, can be reasonably expected to result in personal injury or death.

Information given in this document is believed to be accurate and reliable. However, no responsibility is assumed for the consequences of its use nor for any infringement of patents or other rights of third parties which may result from its use. Specifications are subject to change without notice.

14.6 Disclaimer: Intended Use

The data specified in this user manual is intended solely for the purpose of product description. No representations or warranties, either express or implied, of merchantability, fitness for a particular purpose



or of any other nature are made hereunder with respect to information/specification or the products to which information refers and no guarantee with respect to compliance to the intended use is given.

In particular, this also applies to the stated possible applications or areas of applications of the product. TRINAMIC products are not designed for and must not be used in connection with any applications where the failure of such products would reasonably be expected to result in significant personal injury or death (safety-Critical Applications) without TRINAMIC's specific written consent.

TRINAMIC products are not designed nor intended for use in military or aerospace applications or environments or in automotive applications unless specifically designated for such use by TRINAMIC. TRINAMIC conveys no patent, copyright, mask work right or other trade mark right to this product. TRINAMIC assumes no liability for any patent and/or other trade mark rights of a third party resulting from processing or handling of the product and/or any other use of the product.

14.7 Collateral Documents & Tools

This product documentation is related and/or associated with additional tool kits, firmware and other items, as provided on the product page at: www.trinamic.com.



15 Revision History

15.1 Firmware Revision

Version	Date	Author	Description
3.19	2016-JUL-13	OK	First release.
3.20	2017-JUN-17	OK	Save parameter function fixed.
3.21	2018-JAN-10	OK	CSP mode included.
3.22	2019-FEB-11	OK	CSV mode included. Internal performance optimized. Automatic brake control switched off by default (default value of object 200C _h sub-index 2 now 0).

Table 355: Firmware Revision

15.2 Document Revision

Version	Date	Author	Description
1.01	2016-JUL-16	OK	First release.
1.02	2016-NOV-29	OK	Block diagrams included.
1.03	2017-JUN-09	OK	CSP mode added (firmware rev. 3.20).
1.04	2018-JAN-10	OK	Includes firmware V3.21.
1.05	2019-FEB-13	OK	Includes firmware V3.22. CSV mode added. SixPoint™ ramp added.

Table 356: Document Revision

