

THIS DRAWING IS UNPUBLISHED. RELEASED FOR PUBLICATION
 © COPYRIGHT 2017 TE Connectivity ALL RIGHTS RESERVED.

REVISIONS				
P	LTR	DESCRIPTION	DATE	APVD
	A	RELEASE TO PRODUCTION	18 JUN 2020	AY PS

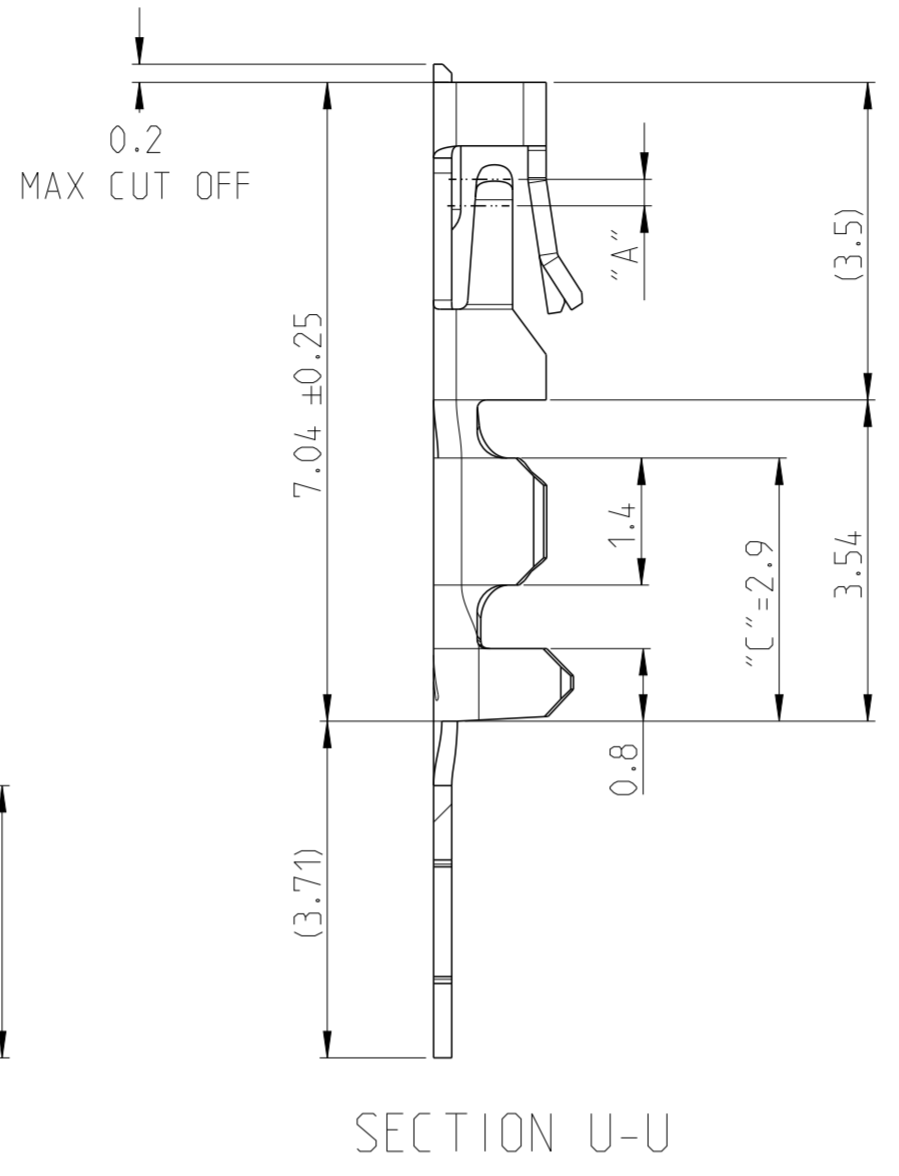

- NOTES:
- 1 MATERIAL: PHOSPHOR BRONZE, 0.2mm THICK
 - 2 FINISH: 1.27-2.54 μm TIN ALL OVER UNDERPLATE 1.27 μm MIN NICKEL ALL OVER
 - 3 CONTACT AREA "A": MIN 0.1 μm THK GOLD CRIMP AREA "C" : 1.27 - 2.54 μm THK TIN UNDERPLATE 1.27 μm MIN NICKEL ALL OVER
 - 4 CONTACT AREA "A" : MIN 0.38 μm THK GOLD CRIMP AREA "C" : 1.27 - 2.54 μm THK TIN UNDERPLATE 1.27 μm MIN NICKEL ALL OVER
 - 5 CONTACT AREA "A" : MIN 0.76 μm THK GOLD CRIMP AREA "C" : 1.27 - 2.54 μm THK TIN UNDERPLATE 1.27 μm MIN NICKEL ALL OVER
6. APPLICABLE HOUSINGS :
 SINGLE ROW : 2316102
 DUAL ROW : 2316108, 2316109

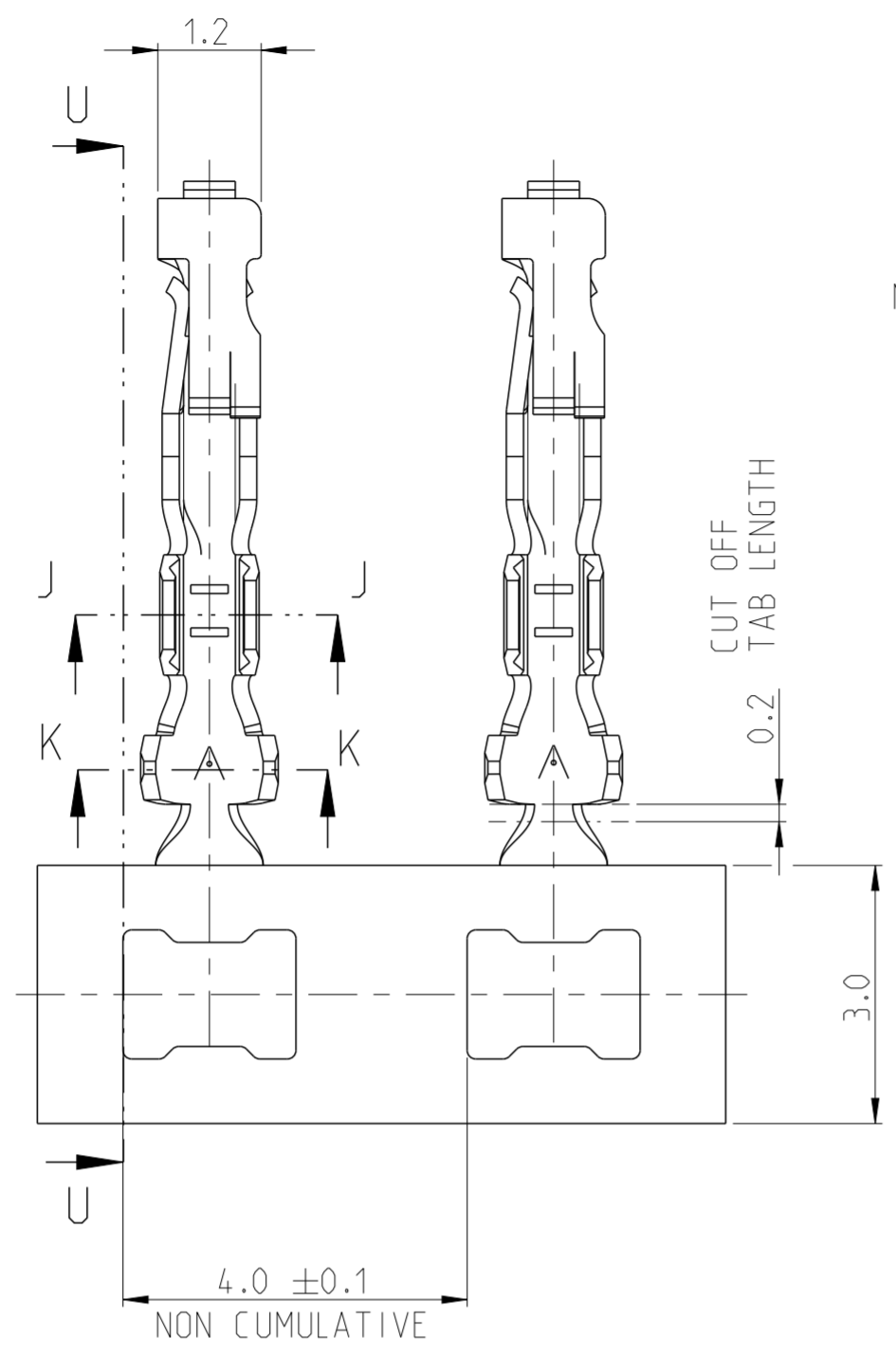
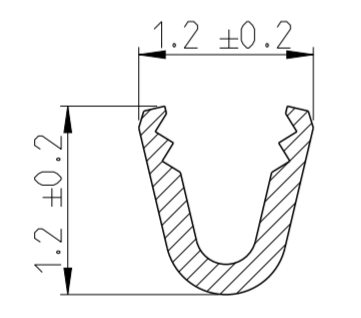

SECTION J-J
20:1

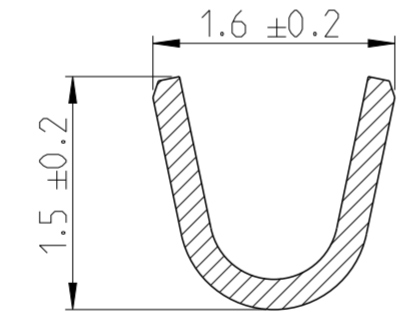

SECTION K-K
20:1

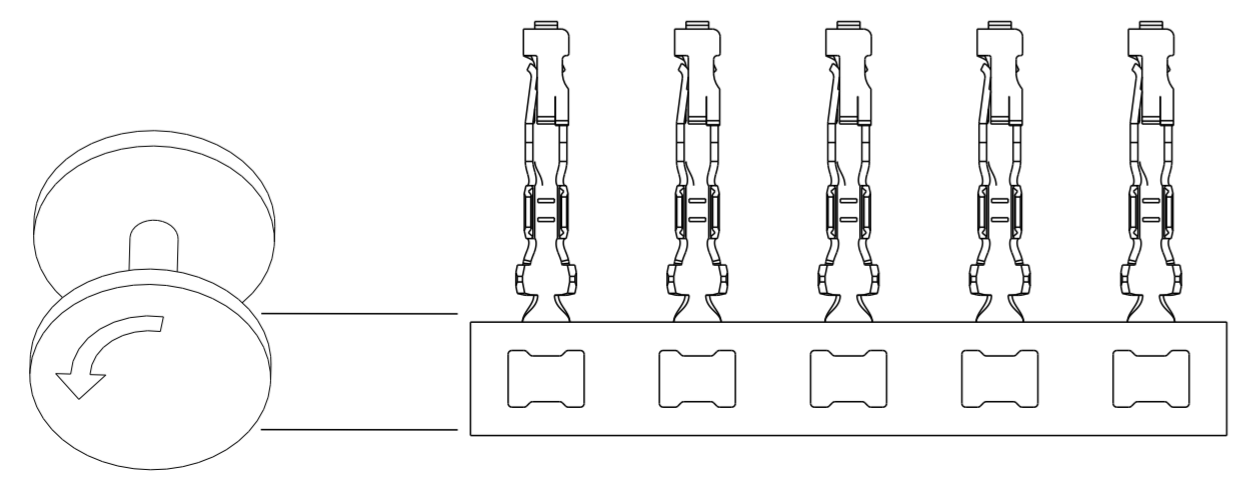

(CRIMP UP)

WIRE RANGE: 0.05-0.08 mm² (30-28 AWG)
 INSULATION RANGE: Ø0.5-Ø1.0mm

5	-	5-2316114-6	LOOSE PIECE - HANDTOOL
5	30,000	5-2316114-5	FOR OCEAN APPLICATOR
4	-	4-2316114-5	LOOSE PIECE - HANDTOOL
4	30,000	4-2316114-4	FOR OCEAN APPLICATOR
3	-	3-2316114-4	LOOSE PIECE - HANDTOOL
3	30,000	3-2316114-3	FOR OCEAN APPLICATOR
2	-	2-2316114-3	LOOSE PIECE - HANDTOOL
2	30,000	2-2316114-2	FOR OCEAN APPLICATOR
FINISH	QTY PER REEL	PART NUMBER	TOOLING

THIS DRAWING IS A CONTROLLED DOCUMENT.

DIMENSIONS: mm	TOLERANCES UNLESS OTHERWISE SPECIFIED:	DWN SOURAV DAS 29OCT2017	TE Connectivity
	0 PLC ±	CHK RAKSHITH R NAYAK 29OCT2017	
	1 PLC ±0.15	APVD PRASHANTH 08DEC2017	
	2 PLC ±0.10	PRODUCT SPEC 108-64040-1	
MATERIAL SEE NOTE	FINISH -	APPLICATION SPEC 114-32173	NAME AMPMODU 2mm RECEPTACLE, wTB CRIMP CONTACT, AWG 30-28
		WEIGHT -	SIZE A2 CAGE CODE 00779 DRAWING NO C-2316114 RESTRICTED TO -
		CUSTOMER DRAWING	SCALE 5:1 SHEET 1 OF 1 REV A