



<http://www.hioki.com>



All regional contact information

**HEADQUARTERS**  
81 Koizumi  
Ueda, Nagano 386-1192 Japan

**HIOKI EUROPE GmbH**  
Rudolf-Diesel-Strasse 5  
65760 Eschborn, Germany  
hioki@hioki.eu

1906 EN

Edited and published by HIOKI E.E. CORPORATION

Printed in Japan

- CE declarations of conformity can be downloaded from our website.
- Contents subject to change without notice.
- This document contains copyrighted content.
- It is prohibited to copy, reproduce, or modify the content of this document without permission.
- Company names, product names, etc. mentioned in this document are trademarks or registered trademarks of their respective companies.

### Warranty

Warranty malfunctions occurring under conditions of normal use in conformity with the Instruction Manual and Product Precautionary Markings will be repaired free of charge. This warranty is valid for a period of three (3) year from the date of purchase. Please contact the distributor from which you purchased the product for further information on warranty provisions.

### Introduction

Thank you for purchasing the HIOKI Model 9322 DIFFERENTIAL PROBE. To obtain maximum performance from the device, please read this manual first, and keep it handy for future reference.

### Overview

The 9322 is a differential probe that connects to input of 8800 series Memory HiCorder input unit. After high voltage is input to H and L terminal and divided by 1/1000, the difference is output as signal to GND.

## Inspection and Maintenance

### Initial Inspection

When you receive the device, inspect it carefully to ensure that no damage occurred during shipping. If damage is evident, or if it fails to operate according to the specifications, contact your dealer or Hioki representative.

### Confirming package contents

- 9322 Differential Probe...1
- Alligator clip.....1 set (Red/Black)
- 9243 Grabber Clip.....1 set (Red/Black)
- C0203 Carrying Case.....1
- Instruction manual.....1

### Preliminary Checks

- Before using the device the first time, verify that it operates normally to ensure that the no damage occurred during storage or shipping. If you find any damage, contact your dealer or Hioki representative.
- Before using the device, make sure that the insulation on the probes is undamaged and that no bare conductors are improperly exposed. Using the device in such conditions could cause an electric shock, so contact your dealer or Hioki representative for repair.

### Maintenance and Service

- To clean the device, wipe it gently with a soft cloth moistened with water or mild detergent. Never use solvents such as benzene, alcohol, acetone, ether, ketones, thinners or gasoline, as they can deform and discolor the case.
- If the device seems to be malfunctioning, contact your dealer or Hioki representative.
- Pack the device so that it will not sustain damage during shipping, and include a description of existing damage. We cannot accept responsibility for damage incurred during shipping.

## Safety

This manual contains information and warnings essential for safe operation of the device and for maintaining it in safe operating condition. Before using it, be sure to carefully read the following safety precautions.

### **⚠ DANGER**

This device is designed to comply with IEC 61010 Safety Standards, and has been thoroughly tested for safety prior to shipment. However, mishandling during use could result in injury or death, as well as damage to the device. Be certain that you understand the instructions and precautions in the manual before use. We disclaim any responsibility for accidents or injuries not resulting directly from device defects.

### Safety Symbol

	In the manual, the ⚠ symbol indicates particularly important information that the user should read before using the device. The ⚠ symbol printed on the device indicates that the user should refer to a corresponding topic in the manual (marked with the ⚠ symbol) before using the relevant function.
	Indicates that dangerous voltage may be present at this terminal.
	Indicates AC (Alternating Current).
	Indicates DC (Direct Current).
	Indicates both DC (Direct Current) and AC (Alternating Current).
	Indicates a grounding terminal.

The following symbols in this manual indicate the relative importance of cautions and warnings.

<b>⚠ DANGER</b>	Indicates that incorrect operation presents an extreme hazard that could result in serious injury or death to the user.
<b>⚠ WARNING</b>	Indicates that incorrect operation presents a significant hazard that could result in serious injury or death to the user.
<b>⚠ CAUTION</b>	Indicates that incorrect operation presents a possibility of injury to the user or damage to the device.
<b>NOTE</b>	Indicates advisory items related to performance or correct operation of the device.

### Measurement categories

This device complies with CAT II safety requirements. To ensure safe operation of measurement devices, IEC 61010 establishes safety standards for various electrical environments, categorized as CAT II to CAT IV, and called measurement categories. These are defined as follows.

**CAT II:** Primary electrical circuits in equipment connected to an AC electrical outlet by a power cord (portable tools, household appliances, etc.). CAT II covers directly measuring electrical outlet receptacles.

**CAT III:** Primary electrical circuits of heavy equipment (fixed installations) connected directly to the distribution panel, and feeders from the distribution panel to outlets.

**CAT IV:** The circuit from the service drop to the service entrance, and to the power meter and primary overcurrent protection device (distribution panel).

Using a measurement device in an environment designated with a higher-numbered category than that for which the device is rated could result in a severe accident, and must be carefully avoided. Use of a measurement instrument that is not CAT-rated in CAT II to CAT IV measurement applications could result in a severe accident, and must be carefully avoided.

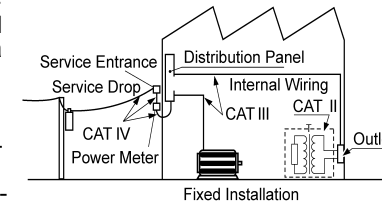

## Usage Notes

Follow these precautions to ensure safe operation and to obtain the full benefits of the various functions.

### **⚠ DANGER**

Note the following maximum input voltage and maximum rated voltage to earth. If their voltages are exceeded, this device will be damaged and personal injury will result. Therefore, do not perform measurement in this case.

- Maximum input voltage 2000 V DC, 1000 V AC
- Maximum rated voltage to earth  
When using the 9243 Grabber clip:  
(CAT II) 1500 V AC/DC, (CAT III) 600 V AC/DC  
When using the Alligator clip:  
(CAT II) 1000 V AC/DC, (CAT III) 600 V AC/DC

### **⚠ WARNING**

- Do not allow the device to get wet, and do not take measurements with wet hands. This may cause an electric shock.
- To avoid shock and short circuits, turn off all power before connecting probes.
- The 9322 input part is applied with high voltage. To avoid electric accident, be sure to turn off the power of equipment to be measured before connecting. After connection is properly handled, turn the power on.

### **⚠ CAUTION**

- Do not store or use the device where it could be exposed to direct sunlight, high temperature or humidity, or condensation. Under such conditions, the device may be damaged and insulation may deteriorate so that it no longer meets specifications.
- This device is not designed to be entirely water- or dust-proof. Do not use it in an especially dusty environment, nor where it might be splashed with liquid. This may cause damage.
- To avoid damage to the device, protect it from physical shock when transporting and handling. Be especially careful to avoid physical shock from dropping.
- To prevent an electric shock accident, confirm that the white or red portion (insulation layer) inside the cable is not exposed. If a color inside the cable is exposed, do not use the cable.

### **NOTE**

This product may cause interference if used in residential areas. Such use must be avoided unless the user takes special measures to reduce electromagnetic emissions to prevent interference to the reception of radio and television broadcasts.

## Specifications

Accuracy guaranteed for one year at 23±5°C (73±9°F), 35 to 80%RH, after 30 minutes or more of warming-up time  
Guaranteed accuracy period: 1 year  
Guaranteed accuracy period after adjustment made by Hioki: 1 year

Product warranty period	3 years
Maximum input voltage	2000 V DC, 1000 V AC
Maximum rated voltage to earth	9243 Grabber Clip: 1500 V AC/DC (CAT II), 600 V AC/DC (CAT III) Alligator clip: 1000 V AC/DC (CAT II), 600 V AC/DC (CAT III)
Attenuation ratio	1000:1
Output	BNC terminal (DC/AC/RMS output)
DC output	
Amplitude accuracy	±1%f.s (1000 V DC max.), ±3%f.s (2000 V DC max.) f.s. = 2000 VDC
Frequency characteristic	DC to 10 MHz (±3 dB)
RMS output	
Amplitude accuracy	±1%f.s. (DC, 40 Hz to 1 kHz), ±4%f.s. (1 kHz to 100 kHz) f.s. = 1000 V AC
Frequency characteristic	DC, 40 Hz to 100 kHz
Response speed	200 ms max. (400 V AC)
AC output	
Frequency characteristic	1 kHz to 10 MHz (±3 dB, low cut-off frequency 1 kHz±300 Hz)
Common mode rejection ratio	10000 :1 or more (50/60 Hz, input shorted, Input:output) 1000 :1 or more (100 kHz, 1 MHz, input shorted, Input:output)
Temperature characteristic	1 mV/°C max. (output)
Input resistance	9 MΩ±2%, 10 pF max. (between H and L) 4.5 MΩ±2%, 20 pF max. (between H, L and main unit)
Operating temperature & humidity	0 to 40°C (32 to 104°F), 35 to 80% RH (no condensation)
Storage temperature & humidity	-10 to 50°C (14 to 122°F), 20 to 90% RH (no condensation)
Operating environment	Indoors, altitude up to 2000 m (6562-ft.)
Effect of radiated radio-frequency electromagnetic field	Within ±5%f.s. at 3 V/m
Effect of conducted radio-frequency electromagnetic field	Within ±5%f.s. at 3 V
Applicable Standards	
Safety	EN 61010 Pollution degree 2, Measurement category II, (Anticipated Transient Overvoltage: 6000 V)
EMC	EN 61326 Class A
Dimensions and mass	Approx. 70W x 150H x 25D mm (2.76"W x 5.91"H x 0.98"D), Approx.350 g (12.3 oz.)

Power supply	+5 V to +12 V 300 mA max. DC jack: $\phi 5.5 \times 2.1$ mm • Supplied from the 9418-15 AC Adapter • Supplied from the 9687 Probe Power Unit with the 9248 Power Cord. • Supplied from the Z5021 Probe Power Unit with the 9248 Power Cord. • Supplied from the logic connector of the main unit with the 9324 Power Cord. <sup>*1</sup> • Supplied from the sensor connector of the 8940 F/V Unit with the 9325 Power Cord. <sup>*2</sup> • Supplied from the power terminal of the 8950 Analog Unit, 8952 RMS/DC Unit, 8953/8953-10 High Resolution Unit, or 8955 F/V Unit with the 9328 Power Cord
Accessories	• Alligator Clips $\times 1$ set (Red/Black) • 9243 Grabber Clips $\times 1$ set (Red/Black) • C0203 Carrying Case • Instruction Manual
Options <sup>*4</sup>	• 9418-15 AC Adapter • 9248 Power Cord (for the 9687, Z5021) • 9324 Power Cord <sup>*3</sup> (for the logic connector) • 9325 Power Cord (for the sensor connector of the 8940) • 9328 Power Cord (for the 8950, 8952, 8953, 8953-10, 8955) • 9243 Grabber Clip • 3853 Carrying Case • C0203 Carrying Case

\*1: The number of the connectable device varies depending on the Memory HiCorder used. Use the 9324 to connect the device to the large logic-conductor. Use both of the 9324 and 9323 to connect the device to the small logic-conductor.  
 \*2: The number of the connectable device varies depending on the Memory HiCorder used.  
 \*3: Discontinued product  
 \*4: The following options are available for the instrument. To purchase an option, please contact your authorized Hioki distributor or reseller. Options are subject to change. Please check Hioki's website for the latest information.

## Using Method

**⚠ DANGER**  
 To avoid an electric shock, use a grounded 2-pole outlet and the accessory power cord to supply power from the Memory HiCorder or its options to the 9322.

**⚠ CAUTION**

- When disconnecting the BNC connector, be sure to release the lock before pulling off the connector. Forcibly pulling the connector without releasing the lock, or pulling on the cable, can damage the connector.
- To prevent damage to the instrument and device, turn off the power to all devices before plugging or unplugging any cables or peripherals.

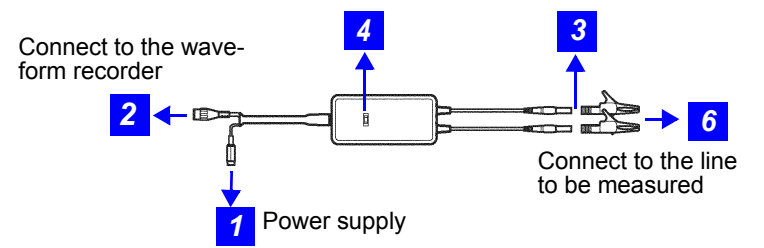

**3** Connect the alligator clip or 9243 Grabber Clip to the input leads.  
 Use either one of them, depending on the object to measure.

**4** Select the output using the output switch.

DC	After each H and L terminal signal is divided into voltage by 1/1000, the difference is output as signal to GND.
AC	By converting DC signal to AC, impulse voltage is sampled on carrier voltage.
RMS	Applies RMS conversion on DC output signal and outputs as level change.

**5** Set up input range scaling.  
 (Use the Memory HiCorder main unit to set up.)  
 See "About input range scaling" for details.

**6** Connect to the object and then perform measurement.

### How to supply power from the Memory HiCorder to the 9322

**⚠ DANGER**  
 To avoid an electric shock, use a grounded 2-pole outlet and the accessory power cord.

To use 9325 Power Cord (8940 F/V UNIT), use appropriate units with versions listed below. Contact your dealer or HIOKI representative for details.

- Model 8826 : After Ver.2.30 (Unit No.1999-0338386)
- Model 8841, 8842 : After Ver.2.31
- Model 8835-01 : After Ver.1.10, 9540-01 Install model after Ver.5.10
- Model 8860, 8861, 8860-50, 8861-50 : After Ver.1.00 (Model 8835: No power available from sensor connector terminal)

Memory HiCorder	Logic terminal of instrument			Sensor connector terminal of 8940 F/V Unit <sup>*1</sup>			9687 Probe Power Unit for the 8860 series only <sup>*2</sup>		Z5021 Probe Power Unit for the MR6000 series only	
	Power code required	Max. number of the connectable 9322	Number of logic probes available concurrently	Power code required	Max. number of the connectable 9322	Number of logic probes available concurrently with clamp sensor	Power code required	Max. number of the connectable 9322	Power code required	Max. number of the connectable 9322
MR6000 MR6000-01	-	-	-	-	-	-	-	-	9248	8 <sup>*4</sup>
8870 <sup>*1</sup> MR8870 MR8880	No power available from logic terminal			-	-	-	-	-	-	-
MR8875	No power available from logic terminal			-	-	-	-	-	-	-
8860 <sup>*1</sup> 8860-50 <sup>*1</sup> 8861 <sup>*1</sup> 8861-50 <sup>*1</sup>	9323 <sup>*2</sup> + 9324 <sup>*1</sup>	2	9322 $\times$ 2: N/A 9322 $\times$ 1: 3	9325 <sup>*2</sup>	6	8	9248	8 <sup>*3</sup>	-	-
8855 <sup>*1</sup>	9323 <sup>*2</sup> + 9324 <sup>*1</sup>	2	9322 $\times$ 2: N/A 9322 $\times$ 1: 3	-	-	-	-	-	-	-
8847 <sup>*1</sup> MR8847-01 <sup>*1</sup> MR8847-02 <sup>*1</sup> MR8847-03 <sup>*1</sup> MR8847-51 MR8847-52 MR8847-53 MR8827 MR8740 MR8741	9323 <sup>*2</sup> + 9324 <sup>*1</sup>	4	9322 $\times$ 4: N/A 9322 $\times$ 3: N/A 9322 $\times$ 2: N/A 9322 $\times$ 1: 2	-	-	-	-	-	-	-
8841 <sup>*1</sup> 8842 <sup>*1</sup>	9324 <sup>*1</sup>	1	N/A	9325 <sup>*2</sup>	6	4	-	-	-	-
8835 <sup>*1</sup>	9324 <sup>*1</sup>	1	N/A	No power available from Sensor connector terminal			-	-	-	-
8835-01 <sup>*1</sup>	9324 <sup>*1</sup>	1	N/A	9325 <sup>*2</sup>	4	4	-	-	-	-
8826 <sup>*1</sup>	9324 <sup>*1</sup>	4	9322 $\times$ 4: N/A 9322 $\times$ 3: 4 9322 $\times$ 2: 6 9322 $\times$ 1: 7	9325 <sup>*2</sup>	6	6	-	-	-	-

\*1: Discontinued product  
 \*2: Product of which production will be discontinued  
 \*3: The number of the connectable 9322 varies depending on devices, such as Clamp on Probes, connected to the 9687 Probe Power Unit.

9322 only	Total: 8
Including with 3273	Total: 8
Including with 3273-50, 3274 and 3276	Total: 6
Including with 3275	Total: 5

\*4: Connecting the Z5021 Probe Power Unit, 8971 Current Unit, or U8977 3CH Current Unit reduces the number of connectable devices, which include Current Sensors, to up to nine.

## Parts Names

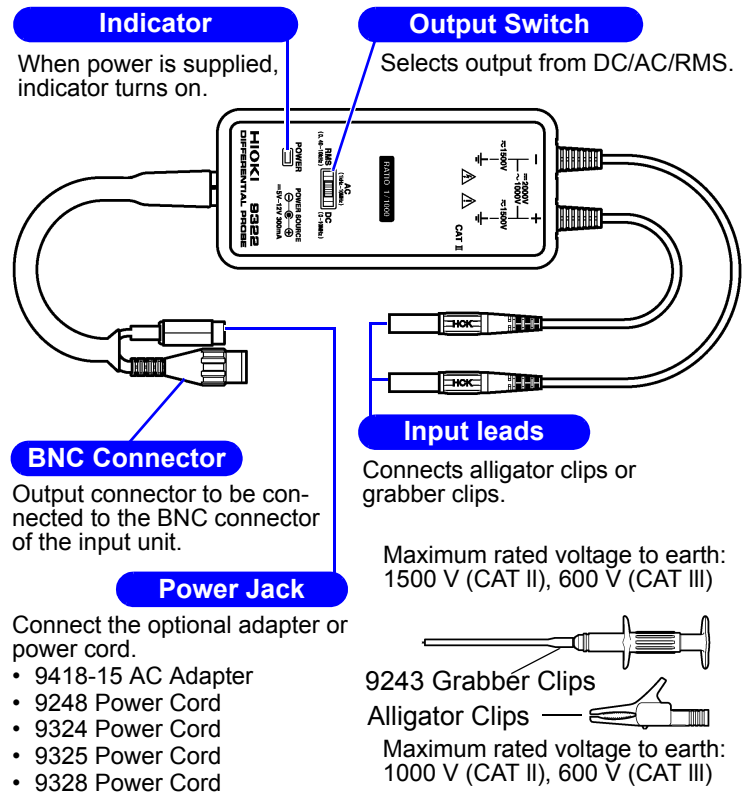

**1** Connect the optional AC adapter or power cord to the power jack.  
 Depending on the usage, the AC adapter and power cord to use for the connection may be different.  
 (example: 9324 Power Cord)

Power cord  
 Power jack  
 (When power is supplied, indicator turns on.)

**When power is supplied from a commercial power source:**  
 Connect the 9418-15 AC Adapter.

**When power is supplied from the input units of the Z5021 Probe Power Unit.**  
 Connect the 9248 Power Cord.

**2** Connect the BNC connector to the input unit of the Memory HiCorder.

Connect  
 Engage the BNC connector grooves with the connector-guide projections, and turn the connector clockwise to lock the components.

Remove  
 Turn the connector counter-clockwise and pull it out.