

## Technical Datasheet

**Product Code:** PCB3BKFV

**Description:** 250/400V 16A 3 Pole Female PCB Mount Connector - Vertical Mounted

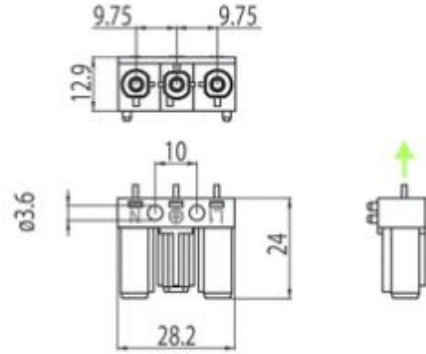

### General Information

<b>Rating</b>	20A 250V~
<b>Colour</b>	Black
<b>Materials</b>	Body: Polyamide (PA6/6 V0) Contacts: Brass Silver Plated
<b>Number Of Poles</b>	3
<b>Terminal Type</b>	PCB
<b>Mounting Position</b>	Vertical
<b>Compatible Male Plug</b>	PCB3BKMV or PCB3BKMH
<b>Temperature Rating</b>	100°C
<b>Ingress Protection</b>	IP20

**Additional Information** Installation couplers are only intended for connection and disconnection without load. This installation coupler is not suitable for installation in readily accessible areas.

**Standards** EN61535: 2008 +A1: 2013,  
EN 60335-1

