

SEM104 SERIES

SEM104P Pt100 Temperature Transmitter

SEM104TC Thermocouple Temperature Transmitter



Status Instruments Ltd, Green Lane Business Park, Tewkesbury, Glos. GL20 8DE

Tel: +44 (0)1684 296818 • Fax: +44 (0)1684 293746

Email: sales@status.co.uk • Web: www.status.co.uk

INDEX

SECTION	CONTENTS	PAGE NO.
	SEM104P	1
1.0	DESCRIPTION	2
2.0	SPECIFICATION	2
3.0	INSTALLATION	2-4
4.0	RANGES	5-7
	SEM104TC	8
1.0	DESCRIPTION	9
2.0	SPECIFICATION	9
3.0	INSTALLATION	10-11
4.0	RANGES	12-13

SEM104P

Pt100 TEMPERATURE TRANSMITTER



1.0 DESCRIPTION

The SEM104P is a temperature transmitter designed to accept a standard platinum resistance sensor (Pt100 2 or 3 wire) to BS EN60751, BS1904 or DIN43760 and convert the temperature to industrial (4 to 20) mA. It is housed in a purpose designed DIN standard connecting block enclosure.

The transmitters are available in 6 standard factory calibrated ranges, but the transmitter can be user re-ranged to operate over most temperature ranges encountered in both industrial and building management applications. Non standard ranges can be supplied to special order. The enclosure provides trim potentiometer access, allowing fine re-calibration adjustments to be made at both ends of the scale.

2.0 SPECIFICATION @ 20 °C

Input	Pt100 sensor to BS EN60751, BS 1904 or DIN 43760 100 Ω @ 0 °C. FI = 38.5 Ω , 2 or 3 wire.
Output	(4 to 20) mA loop powered, maximum 30 mA
Loop Supply	(10 to 30) VDC
Loop Resistance	700 Ω @ 24 V
Loop Protection	Reverse connection protected
Loop Sensitivity	10 μ A/V
Accuracy	\pm 0.2 °C plus \pm 0.2 % of reading
Temp Stability	Zero Drift
Span	Typically 0.05 % full range output/°C
Ambient Temp	Typically 0.002 % full range output/°C (0 to 70) °C operating (-40 to 70) °C storage
Ambient Humidity	(0 to 95) % non condensing
Connection	Screw terminal
Cable Size	Recommended maximum wire 2.5 mm ²
EMC	Conforms to BS EN 0081-1, BS EN50082-1

3.0 INSTALLATION

3.1 MECHANICAL

The transmitter is mounted using two 5.5 mm diameter holes, on standard 33 mm fixing centres. This transmitter has been specifically designed to be mounted inside a DIN standard probe head enclosure, which must provide adequate protection from moisture, corrosive atmosphere etc. All cable entries should be sealed using the correct size cable gland. Care must be taken when locating the transmitter to ensure the ambient temperature will remain inside the specified range of (0 to 50) °C. The diagrams below and overleaf show the mechanical layout and a typical application of the transmitter mounted inside a probe head enclosure, with sensor wires entering through the centre hole.

Figure 1

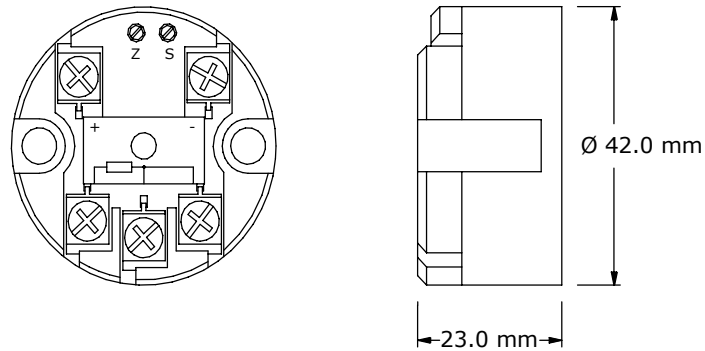

Mounting holes : 2 holes 5.5 mm diameter, 33 mm centres

Centre hole sensor wire entry : 4.0 mm diameter

Figure 2

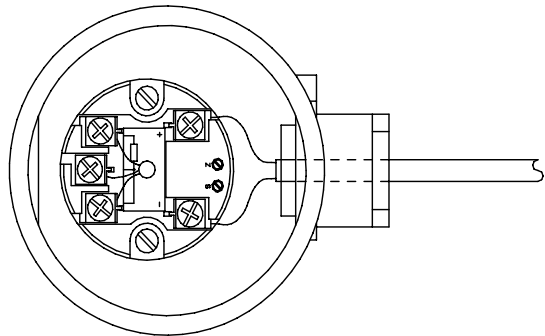

3.2 ELECTRICAL

Connections to the transmitter are made to the screw terminals provided on the top face. To maintain CE compliance, input wires must be less than 3 m in length and output wiring must be screened cable, with the screen earthed at one end only. All three input wires must have the same core diameter to maintain equal lead resistance in each wire. A hole is provided through the centre of the transmitter to allow sensor wires, (entering direct from the probe assembly via a base entry), to be threaded through the transmitter body, direct to the input screw terminals. The screw terminals have been designed to allow all connection wires to enter from either an inner or outer direction.

The transmitter is protected against reverse connection by means of a series diode, therefore incorrect connection of the output wires will result in near zero current flow in the loop. Incorrect connection of the sensor wires will result in the transmitter saturating at either its low or upper limits.

The diagram on the next page shows the method of connection to provide a (4 to 20) mA current loop output. The Pt100 sensor shown would normally take the form of a probe assembly with a three wire output. The output loop shows a 24 VDC power supply, used to provide loop excitation, the transmitter, and a load all connected in series. The load symbol represents other equipment in the loop e.g. indicators, controllers, loggers etc. Sometimes these instruments may come with the 24 V supply built in as standard, this simplifies wiring and reduces cost.

Care must be taken when designing the (4 to 20) mA circuit to ensure that the total burden of the loop, that is the total voltage requirements of all the equipment in the loop added together, does not exceed the power supply voltage. If a number of transmitters are connected in the loop, ensure that only one instrument is tied to ground. Grounding the loop at two points will result in shorting out part of the loop and therefore any transmitters in that part of the loop will not operate.

Figure 3

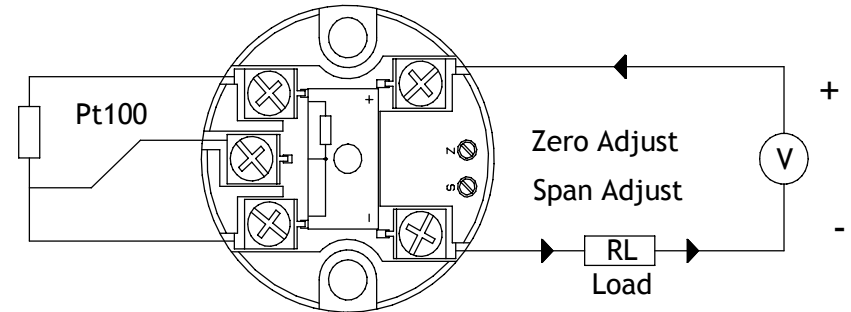

Maximum load resistor, R_L , is calculated as follows :

$$R_L = (V-10)/20 \times 1000$$

For 24 V supply :

$$R_L = (24-10)/20 \times 1000 = 700 \Omega$$

3.3 EMC

This transmitter conforms with EC directive BS EN50081-1 and BS EN50082-1 when correctly installed in a termination head providing at least IP20 protection and fitted with a sensor with less than 3 m of cable.

4.0 RANGES

This transmitter is normally supplied in one of six standard ranges. Other ranges can be supplied at time of order but with the aid of suitable equipment, the user can re-range the transmitter. On board links allow the transmitter to be re-ranged to operate over most common industrial and commercial ranges. Due to the nature of this transmitter, changes in span range affect both (4 and 20) mA calibration points. Ranging the transmitter is very much simplified if calculations are based on the true zero of the transmitter, i.e. the temperature at which the output would in theory be at 0 mA.

To verify that the transmitter will operate over the range you require, please follow the simple procedure listed overleaf, calculating the SPAN and TRUE-ZERO temperatures for your range. Then ensure these temperatures fall into one of the bands for SPAN and TRUE-ZERO listed in the tables overleaf. From the tables select the links you need to make, solder blob them and then follow the calibration procedure to trim the transmitter to the range you require.

NOTE : TRUE-ZERO is the temperature at which theoretical zero current would flow.

- **WARNING!** Re-ranging requires the soldering of small links located on a pcb, housed inside the transmitter. The operator must be experienced in soldering and un-soldering techniques on small PCB, or damage may occur to both PCB and enclosure. If in doubt please state the required range at the time of order, to allow the factory to calibrate for you. It is the users responsibility to ensure that no damage occurs due to lack of care during this re-ranging procedure.

RE-RANGING AND CALIBRATION PROCEDURE

Before you start you will need the following equipment and information:

- Resistance box; accuracy $\pm 0.01 \Omega$ or better to simulate Pt100
- DC milliamp meter (Digital); accuracy 0.05 % on (0 to 20) mA range.
- Power supply; 24 VDC 30 mA minimum output current.
- Suitable wires together with a trim tool and the Pt100 equivalent resistance values for the range limits you require to set, i.e. the 4 mA and 20 mA calibration points.

STEP 1. Decide on the range you require,

Let; T_h = Required Temperature @ 20 mA Output

T_{lo} = Required Temperature @ 4 mA Output

STEP 2. Calculate SPAN $SPAN = T_h - T_{lo}$

STEP 3. Calculate TRUE-ZERO $TRUE-ZERO = T_{lo} - (SPAN/4)$

STEP 4. Look up your SPAN and TRUE-ZERO temperature in the tables overleaf, and note the links that need to be made. Then using a soldering iron, blob the links on the PCB mounted inside the enclosure. Ensure any non called up links, soldered for a previous range, are open circuited by removing the solder blob. Note you will need to remove the enclosure base to gain access to the links. There are eight links in total, (A, B, C, D) affect SPAN, and (W, X, Y, Z) affect TRUE-ZERO.

TABLE 1 SPAN LINKS GROUP A, B, C + D

SPAN °C	SOLDER LINKS
22 to 37	D
37 to 52	B, C
52 to 75	C
75 to 140	A, B
140 to 215	B
215 to 500	A

TABLE 2 TRUE ZERO LINKS, GROUP W, X, Y + Z

TRUE-ZERO °C	SOLDER LINKS
-180 to -166	W, X, Y, Z
-166 to -147	W, X, Y
-147 to -127	W, X, Z
-127 to -108	W, X
-108 to -88	W, Y, Z
-88 to -69	W, Y
-69 to -49	W, Z
-49 to -35	W
-35 to -21	X, Y, Z
-21 to -1	X, Y
-1 to 18	X, Z
18 to 38	X
38 to 57	Y, Z
57 to 77	Y
77 to 96	Z
96 to 100	-

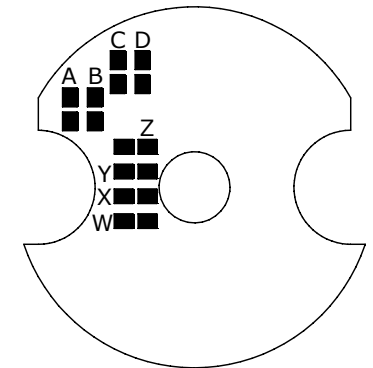

STEP 5. RE-CALIBRATE

- a. Look up your SPAN & TRUE-ZERO temperature in the tables overleaf and note the links that need to be made. Using a soldering iron blob the links on the PCB. Ensure any links not called up, soldered from a previous range, are open circuited by removing the solder blob. Note you will need to remove the enclosure base to gain access to the links. There are 8 links in total, ABCD affect SPAN and WXYZ affect TRUE-ZERO.
- b. Set the resistance box to the equivalent sensor resistance for the temperature you require for 4 mA output. Adjust the Z zero trim potentiometer for $4.00 \text{ mA} \pm 0.01 \text{ mA}$ output current.
- c. Set the resistance box to the equivalent sensor resistance for the temperature you require for 20 mA output. Adjust the S span trim potentiometer for $20.00 \text{ mA} \pm 0.01 \text{ mA}$ output current.
- d. Repeat Steps b & c until both points are in calibration. Note some interaction between adjustments will occur.
- e. Switch off power and remove wires. Mark transmitter with the new range.

EXAMPLE

1. Range (50 to 200) °C.
2. Span = $200 - 50 = 150$
3. True Zero = $50 - (150/4) = 50 - 37.5 = 12.5$
4. Span falls in 140 to 215 range therefore link B is made.
5. True Zero falls in (-1 to 18) °C range therefore links X and Z are made.
6. Check that all other links are open circuit.

SEM104TC

THERMOCOUPLE TEMPERATURE TRANSMITTER

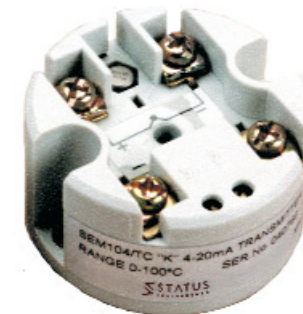

1.0 DESCRIPTION

The SEM104TC is a low cost thermocouple input two wire (4 to 20) mA temperature transmitter. The transmitter is available in a number of standard sensor types and ranges, but if required the user may re-range the transmitter to a preferred range within the limits shown below. Automatic thermocouple cold junction compensation is provided. The output is directly referenced to the mV input, allowing linearisation to be carried out by the loop monitoring instrumentation, if required. The device is housed inside a plastic enclosure, suitable for head mounting into any DIN style enclosure. Screw terminals are provided for wire connections. The enclosure provides access to the range setting links and trim potentiometers.

2.0 SPECIFICATION @ 20 °C

Input	Isolated junction un-grounded thermocouple	
Thermocouple Types	K	T J
Minimum Span °C	75	75 75
Maximum Span °C	1000	400 760
Offset Range °C	± 100	± 100 ± 100
Accuracy (less CJ)	± 0.1 % FS	(0 to 100) °C range
Overall Stability (inc. CJ)	0.04 %/°C (0 to 100) °C range	
Input Impedance	> 1 MΩ	
Lead Resistance	Typical 0.01 °C/Ω, for Type K (0 to 100) °C	
Burn Out	Up scale standard, Down scale by link change.	
Cold Junction	Automatic (0 to 70) °C	
Accuracy	0.2 °C @ 20 °C, tracking ± 0.05 °C/°C	
Output Type	(4 to 20) mA (directly proportional to mV input)	
Supply Voltage	Over-range < 25 mA ; Under-range < 3.5 mA	
Loop Sensitivity	(10 to 30) VDC reverse connection protected.	
Temperature Stability	Zero	Drift typical 0.05 % /°C
Span		Typical 0.002 %/°C
Loop Ripple	Less than 40 uA/V (measured at 1 V ripple 100 Hz)	
Loop Resistance	(VSupply -10)/0.021	
Response Time	2 ms to reach 70 % of final value	
Ambient Temperature	(0 to 70) °C operation, (-40 to 85) °C storage	
Ambient Humidity	(0 to 95) % non condensing	
Connections	Recommended cable size 2.5 mm ²	
EMC Compliant with	EN50081-1	
	EN50082-1X	

3.0 INSTALLATION

3.1 MECHANICAL

The transmitter is mounted using two 5.5 mm diameter holes, on standard 33 mm fixing centres. This transmitter has been specifically designed to be mounted inside a DIN standard probe termination head enclosure, which should provide adequate protection from moisture, corrosive atmosphere etc. All cable entries should be sealed using the correct size cable gland. Care must be taken when locating the transmitter to ensure the ambient temperature will remain inside the specified range of (0 to 70) °C, for best operation keep the ambient within the range (10 to 30) °C.

The diagram below shows the mechanical layout.

Figure 1

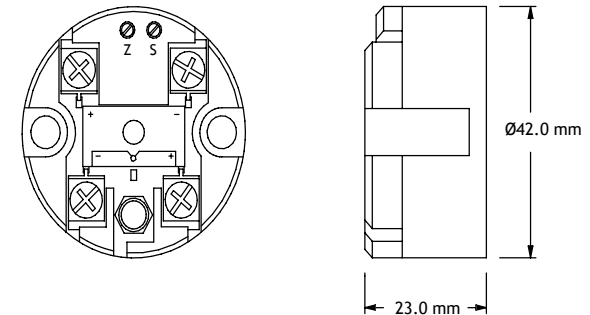

Mounting holes : 2 holes 5.5 mm diameter, 33 mm centres

The diagram below shows a typical application of the transmitter mounted inside a probe head enclosure, with sensor wires entering through the centre hole.

Figure 2

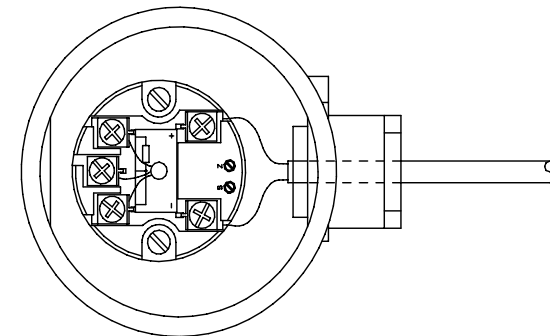

3.2 ELECTRICAL

Connections to the transmitter are made to the screw terminals provided on the top face. No special wires are required for the output connections, but screened twisted pair cables are recommended for long runs. A hole is provided through the centre of the transmitter to allow sensor wires, (entering direct from the probe assembly via a base entry), to be threaded through the transmitter body, direct to the input screw terminals. The screw terminals have been designed to allow all connection wires to enter from an inner or outer direction.

The transmitter is protected against reverse connection by means of a series diode, therefore incorrect connection of the output wires will result in near zero current flow in the loop. Incorrect connection of the sensor wires will result in the transmitter saturating at either its low or upper limits, depending on the setting of the burnout links.

The diagram shows the method of connection to provide a (4 to 20) mA current loop output. The TC sensor shown would normally take the form of a probe assembly with a two wire output. The output loop shows a 24 VDC power supply, used to provide loop excitation, the transmitter, and a load all connected in series. The load symbol represents other equipment in the loop, normally indicators, controllers, loggers etc.

Care must be taken when designing the (4 to 20) mA circuit to ensure that the total burden of the loop, that is the total voltage requirements of all the equipment in the loop added together, does not exceed the power supply voltage. If a number of instruments are connected in the loop, ensure that only one instrument is tied to ground. Grounding the loop at two points will result in shorting out part of the loop and therefore the instruments in that part of the loop will not operate.

NOTE: The thermocouple used with this transmitter **MUST** be isolated from ground. If a grounded thermocouple is used, measurement errors will occur.

Figure 3

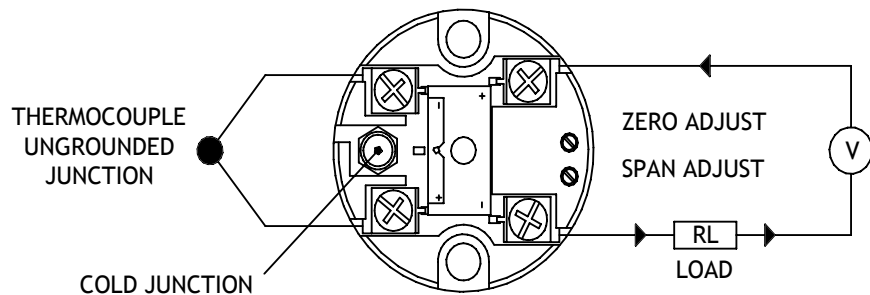

4.0 RANGES

This transmitter is normally supplied as one of the standard ranges, refer to data sheet. Other ranges can be supplied at time of order but with the aid of suitable equipment, the user can re-range the transmitter. On board links allow the transmitter to be re-ranged to operate over most common industrial and commercial ranges.

- **WARNING!** Re-ranging requires the soldering of small links located on a pcb, housed inside the transmitter. The operator must be experienced in soldering and un-soldering techniques on small PCB, or damage may occur to both PCB and enclosure. If in doubt please state the required range at the time of order, to allow the factory to calibrate for you. It is the users responsibility to ensure that no damage occurs due to lack of care during this re-ranging procedure.

PROCEDURE

Before you start you will need the following equipment :

- TC calibrator with internal cold junction compensation
- DC milliamp meter (digital); accuracy 0.05 % on (0 to 20) mA range
- Power Supply; 24 VDC 30 mA minimum
- T/C Compensating wire, wire for (4 to 20) mA loop, plus trim tool
- Soldering iron with fine tip, solder. De-soldering tool.

STEP 1 Decide on the range you require and ensure the transmitter is capable of this range. If a range has not been specified at time of order, the transmitter will leave the factory set as type K, (0 to 1000) °C. Obtain access to the internal PCB by flipping out the base cover, using a small screw driver. Remove any pre-solder links from positions A, B, C, D, X, Y, Z, and J.

STEP 2 Let TL = offset
Locate offset TL on Table 1 and solder blob indicated links.

STEP 3 If TC type is "J" then solder blob link "J"

STEP 4 Let TL = Required Temperature @ 4 mA
Let Th = Required Temperature @ 20 mA
Calculate Transmitter Span Ts = Th - TL
Locate span Ts on Table 2 and solder blob links indicated.

STEP 5 If down scale burn out is required, un-solder link "U" and solder link "D". (If up/down scale burnout is not important then remove both links U + D)

STEP 6 Connect T/C calibrator to +/- input terminals. Ensure wires are the correct type and polarity. Connect + signal terminal to + power supply terminal. Connect mA meter in series with the return wire from the - signal terminal to - terminal on power supply. Turn on. Allow a few minutes before calibration to allow the cold junction to stabilise, after the effects of handling the transmitter. Avoid touching the input terminals and wires during calibration as this will cause errors in the cold junction tracking.

STEP 7 Set calibrator to temperature TL and adjust "Z" potentiometer for 4.00 mA output ± 0.01 mA.

STEP 8 Set calibrator to temperature Th and adjust “S” potentiometer for 20.00 mA output \pm 0.01 mA.

STEP 9 Repeat Step 6 and Step 7 until both points are in tolerance.

STEP 10 Turn off power and remove wires. Mark transmitter with the new range.

TABLE 1 TL OFFSET LINKS GROUP X, Y & Z

TYPE K °C	TYPE T °C	TYPE J °C	SOLDER LINKS
-120 to -99	-150 to -105	-130 to -96	-
-98 to -59	-104 to -62	-95 to -58	X
-58 to -23	-61 to -24	-57 to -23	Y
-22 to 9	-23 to 9	-22 to 9	X, Y
10 to 40	10 to 40	10 to 40	Z
41 to 72	41 to 71	41 to 72	X, Z
73 to 104	72 to 99	73 to 102	Y, Z
105 to 130	100 to 120	103 to 130	X, Y, Z

TABLE 2 TS SPAN LINKS GROUP A, B, C & D

TYPE K °C	TYPE T °C	TYPE J °C	SOLDER LINKS
75 to 148	75 to 137	75 to 102	-
149 to 214	138 to 189	103 to 170	A
215 to 280	190 to 239	171 to 225	B
281 to 341	240 to 284	226 to 283	A, B
342 to 401	285 to 327	284 to 341	C
402 to 464	328 to 371	342 to 409	A, C
465 to 527	372 to 400	410 to 464	B, C
528 to 587	-	465 to 521	A, B, C
588 to 646	-	522 to 578	D
647 to 710	-	579 to 642	A, D
711 to 752	-	643 to 692	B, D
753 to 836	-	693 to 743	A, B, D
837 to 899	-	744 to 793	C, D
90 to 966	-	794 to 851	A, C, D
967 to 1035	-	852 to 900	B, C, D
1036 to 1075	-	901 to 1000	A, B, C, D

NOTE: Max recommended temperature for type J input is 760 °C.

ALSO AVAILABLE:

- Smart In Head Temperature Transmitters
- DIN Rail Mounted Temperature Transmitters
- Panel & Field Temperature Indicators
- Temperature Probes
- Trip Amplifiers
- Signal Conditioners
- And many other products

For further information on all products:



Status Instruments Ltd, Green Lane Business Park, Tewkesbury, Glos. GL20 8DE

Tel: +44 (0)1684 296818 ● Fax: +44 (0)1684 293746

Email: sales@status.co.uk ● Web: www.status.co.uk