

PROFESSIONAL/PRECISION FILM RESISTOR – MRS

FEATURES

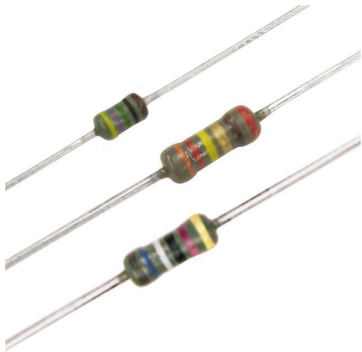

- Metal film technology
- Precision resistors in small outlines
- Low noise
- Non-flammable
- Defined pulse loading capabilities (MRS25)
- High stability and uniformity characteristics (MRS25/MRS25 Precision)
- Various packaging and taping configurations
- Various forming styles



QUICK REFERENCE DATA

DESCRIPTION	MRS16S		MRS25		MRS25 Precision
	Resistance range	4.99Ω - 1MΩ	10Ω - 499kΩ	1Ω - 10MΩ	10Ω - 499kΩ
Tolerance and series	±1%, E24/E96	±0.5%, E24/E96	±1%, E24/E96	±0.5%, E24/E96	±0.1%, E192
Maximum dissipation at T _{amb.} = 70 °C	0.40W		0.60W		0.125W
Limiting voltage (DC or RMS)	200V		350V		300V
Rated voltage ⁽¹⁾	P _n x R				
Temperature coefficient	±50ppm/°C			±25ppm/°C	
Basic specification	IEC 60115-1 and 60115-4				
Climatic category (IEC 60068)	55/155/56			55/125/56	
Stability ΔR/R _{max.} after:	-		-		10Ω - 100Ω 510Ω - 560kΩ
Load:					
R ≤ 100kΩ	±0.5% +0.05Ω		±0.5% +0.05Ω		±0.25% +0.01Ω
R > 100kΩ	±1% +0.05Ω				±0.1% +0.01Ω
Climatic tests:					
R ≤ 100kΩ	±0.5% +0.05Ω		±0.5% +0.05Ω		±0.25% +0.01Ω
R > 100kΩ	±1% +0.05Ω				±0.1% +0.01Ω
Resistance to soldering heat:					
R ≤ 100kΩ	±0.1% +0.05Ω		±0.1% +0.05Ω		±0.05% +0.01Ω
R > 100kΩ	±0.25% +0.05Ω				±0.02% +0.01Ω
Short time overload	±0.25% +0.05Ω		±0.25% +0.05Ω		±0.05% +0.01Ω

(1) Maximum rated voltage is the limiting voltage

MRS

TECHNOLOGY

A homogeneous film of metal alloy is deposited on a high-grade ceramic body. After a helical groove has been cut in the resistive layer, tinned connecting wires of electrolytic are welded copper to the end-caps. The resistors are coated with a green non-flammable lacquer that provides electrical, mechanical, and climatic protection. The coating is resistant to all cleaning solvents in accordance with MIL-STD 202, method 215 e IEC 68-2-45.

MECHANICAL DATA

AXIAL STYLE

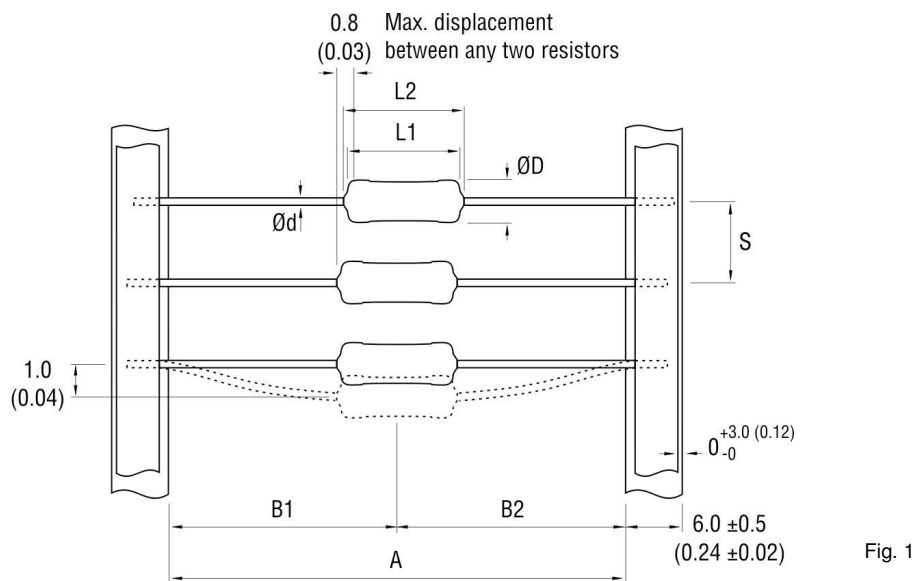

Table 1. Mechanical Data.

PRODUCT	L1 max.	L2 max.	ØD max.	Ød	A	B1 - B2 max.	S	WEIGHT gr/100 pcs
MRS16S	3.2 (0.13)	3.4 (0.14)	1.9 (0.08)	0.45 ± 0.05 (0.018 ± 0.002)	52.5 ± 1.5 (2.07 ± 0.06)	1.2 (0.05)	5.0 ± 0.1 (0.20 ± 0.01)	11.5
					26 ± 1.5 (1.03 ± 0.06)			8.0
MRS25	6.5 (0.26)	7.5 (0.3)	2.5 (0.10)	0.58 ± 0.05 (0.023 ± 0.002)	52.0 ± 1.5 (2.05 ± 0.06)	1.2 (0.05)	5.0 ± 0.1 (0.20 ± 0.01)	22.0
					26.0 ± 1.5 (1.03 ± 0.06)			16.0
MRS25 Precision	6.5 (0.26)	7.5 (0.3)	2.5 (0.10)	0.58 ± 0.05 (0.023 ± 0.002)	52.0 ± 1.5 (2.05 ± 0.06)	1.2 (0.05)	5.0 ± 0.1 (0.20 ± 0.01)	22.0

Dimensions unless specified in mm (inches)

MOUNTING

The resistors are suitable for processing on automatic insertion equipment, cutting and bending machines.

ELECTRICAL CHARACTERISTICS

DERATING

The power that the resistor can dissipate depends on the operating temperature.

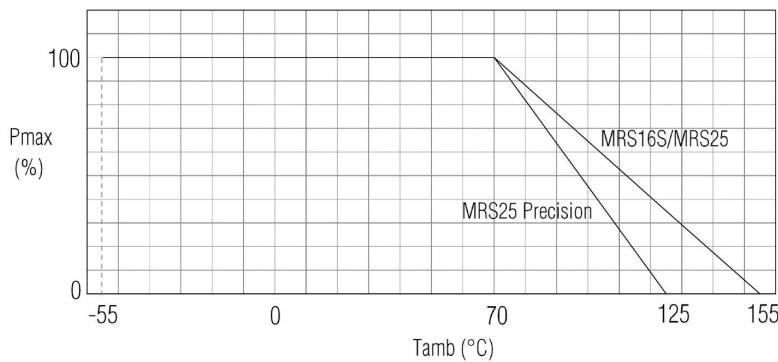

Fig. 2. Maximum dissipation (P_{max}) in percentage of rated power as a function of ambient temperature (T_{amb})

APPLICATION INFORMATION

MRS16S

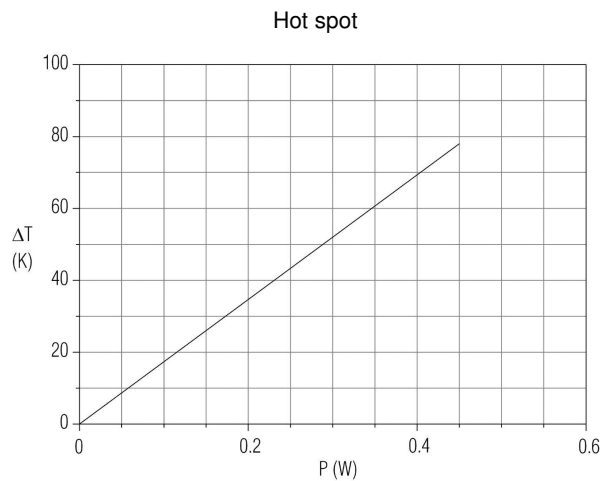

Fig. 3 - Hot spot temperature rise (ΔT) as a function of dissipated power.

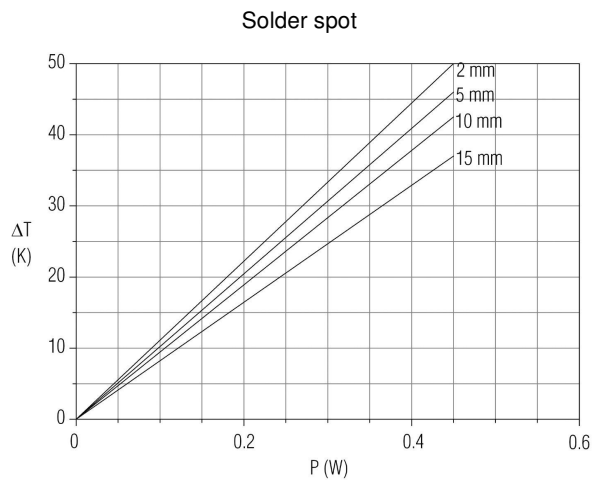

Fig. 4 - Temperature rise (ΔT) at the lead end (soldering point) as a function of dissipated power at various leads after mounting.

MRS25

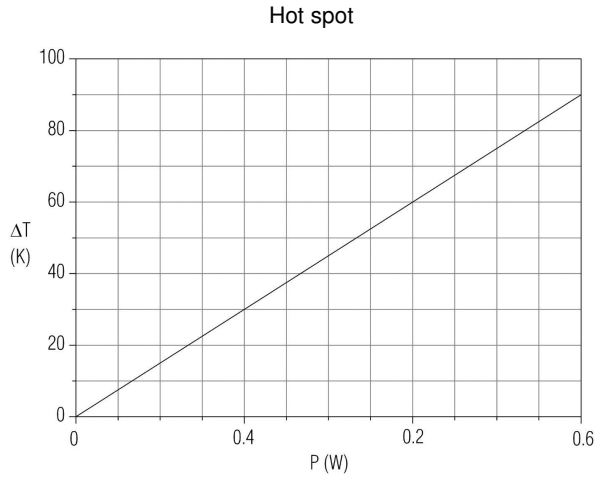

Fig. 5. Hot spot temperature rise (ΔT) as a function of dissipated power

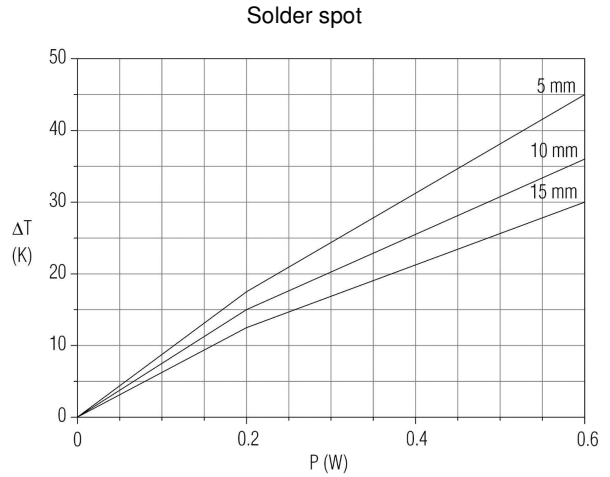

Fig. 6 - Temperature rise (ΔT) at the lead end (soldering point) as a function of dissipated power at various leads after mounting.

PULSE LOADING CAPABILITIES

MRS16S

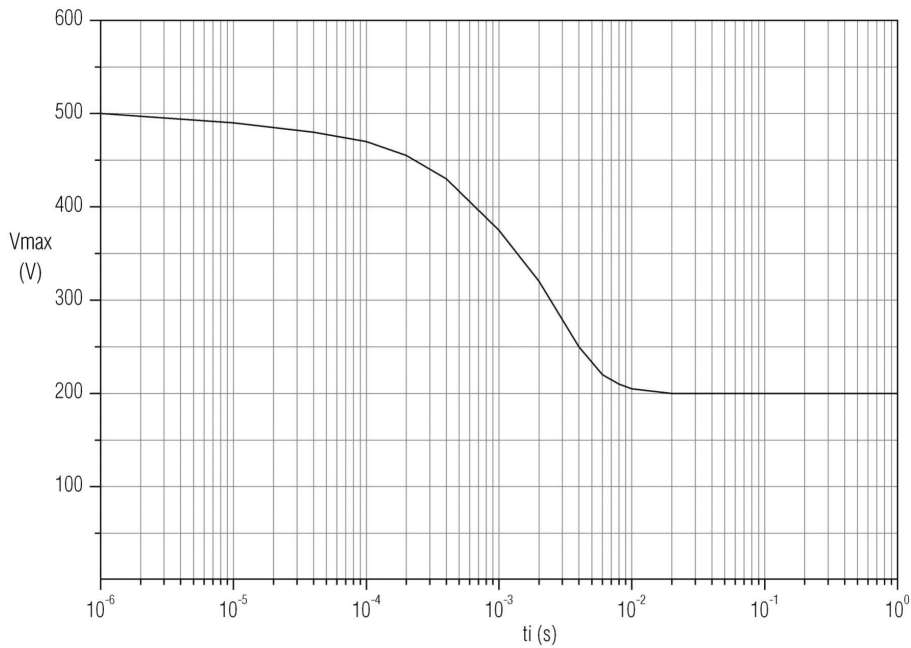

Fig. 7 – Pulse on a regular basis, maximum permissible peak pulse voltage (V_{max}) as a function of pulse duration (t_i)

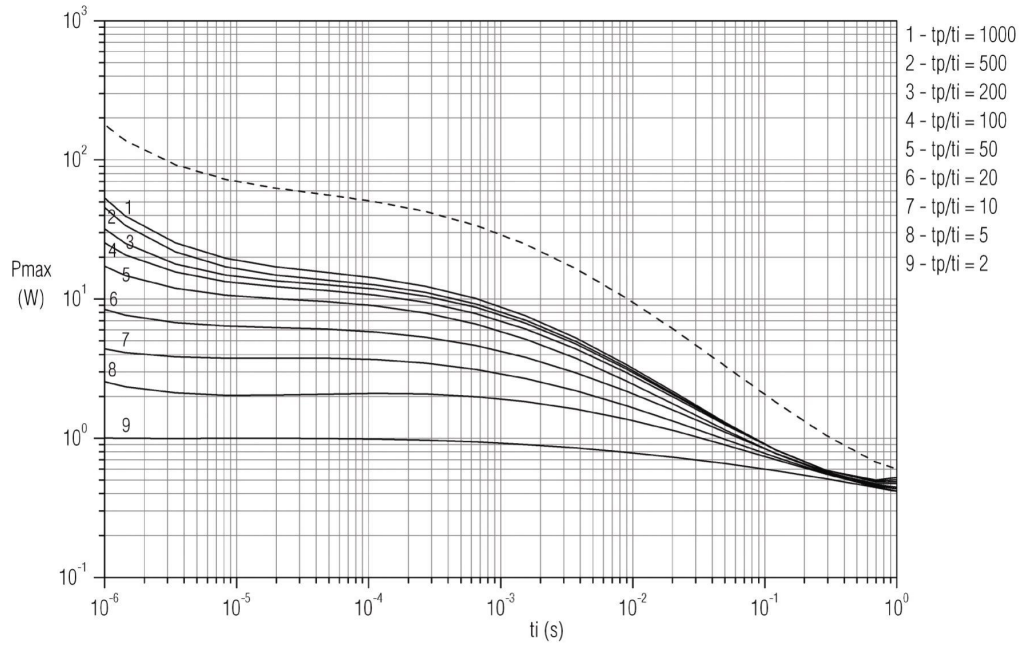

Fig. 8 – Pulse on a regular basis, maximum permissible peak pulse power (P_{max}) as a function of pulse duration (t_i)

MRS25

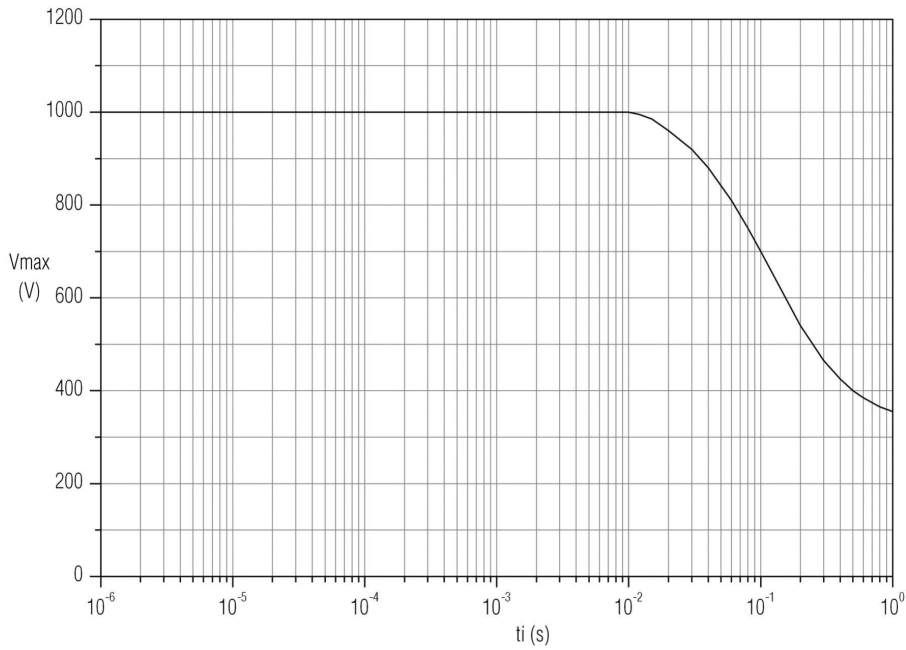

Fig. 9 – Pulse on a regular basis, maximum permissible peak pulse voltage (V_{max}) as a function of pulse duration (t_i).

MRS

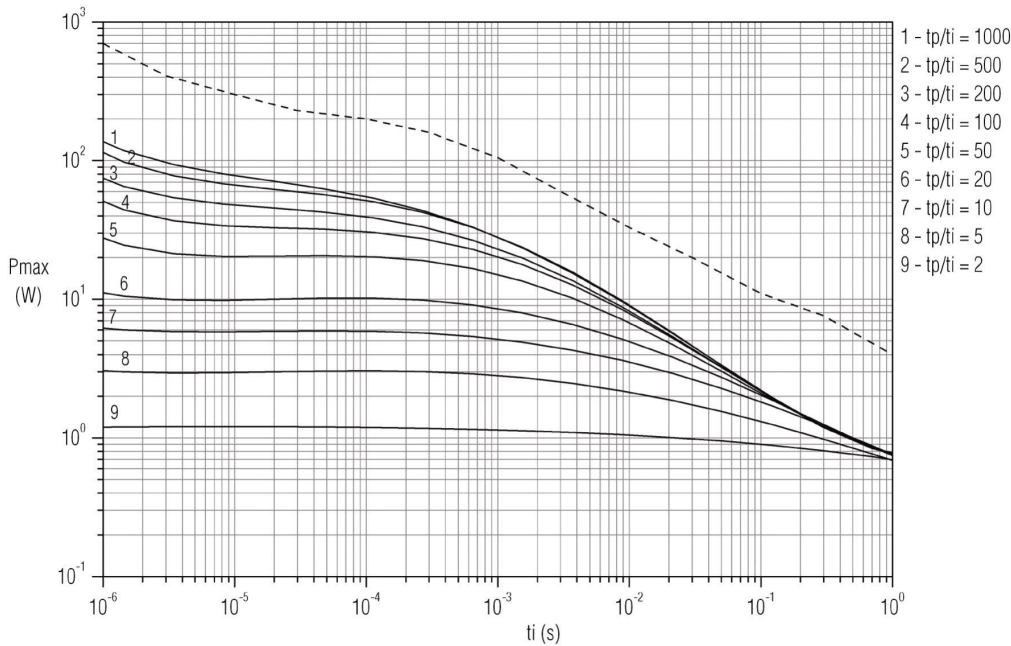

Fig. 10 – Pulse on a regular basis, maximum permissible peak pulse power (P_{max}) as a function of pulse duration (t_i).

MARKING

The nominal resistance and tolerance are marked on the resistor using five or six colored bands in accordance with IEC publication 60062 “Color code for fixed resistors”. Standard values of nominal resistance are taken from the E24/E96 series for resistors with a tolerance of 1%/0.5% (MRS16S/MRS25) and from the E192 series for resistors with tolerance of 0.1% (MRS25 Precision). The values of the E24/E96/E192 series are in accordance with IEC publication 60063.

ORDERING INFORMATION

Table 2. Ordering code.

PRODUT	TOLERANCE	ORDERING CODE	TAPING	LEAD Ø	PACKAGING	QUANTITY (pcs)
MRS16S	±1%	2322 157 1xxxx	52.5 (2.07)	0.45 Cu (0.018)	AMMOPACK	1000
		2322 157 2xxxx			AMMOPACK	5000
		2322 157 3xxxx	REEL		5000	
		2322 157 4xxxx	AMMOPACK		5000	
	±0.5%	2306 158 1xxxx	52.5 (2.07)	0.45 Cu (0.018)	AMMOPACK	1000
		2306 158 2xxxx			AMMOPACK	5000
		2306 158 3xxxx	REEL		5000	
		2306 158 4xxxx	AMMOPACK		5000	

MRS

PRODUT	TOLERANCE	ORDERING CODE	TAPING	LEAD Ø	PACKAGING	QUANTITY (pcs)
MRS25	±1%	2322 156 1xxxx	52.5 (2.07)	0.58 Cu (0.023)	AMMOPACK	1000
		2322 156 2xxxx			AMMOPACK	5000
		2322 156 3xxxx			REEL	5000
		2306 156 4xxxx	26.0 (1.03)		AMMOPACK	4000
	±0.5%	2306 154 1xxxx	52.5 (2.07)	0.58 Cu (0.023)	AMMOPACK	1000
		2306 154 2xxxx			AMMOPACK	5000
		2306 154 3xxxx			REEL	5000
		2306 154 4xxxx	26.0 (1.03)		AMMOPACK	4000
MRS25 Precision	±0.1%	2306 155 1xxxx	52.5 (2.07)	0.58 Cu (0.023)	AMMOPACK	1000
		2306 155 2xxxx			AMMOPACK	5000
		2306 155 3xxxx			REEL	5000

Dimensions unless specified in mm (inches)
Check "**Formed leads**" specification to see related part-numbers

Table 3. Last digit of ordering code

RESISTANCE DECADE	LAST DIGIT
4.99 - 9.76 Ω	8
10 - 97.6 Ω	9
100 - 976 Ω	1
1 - 9.76 kΩ	2
10 - 97.6 kΩ	3
100 - 976 kΩ	4
1 MΩ	5

The resistors have a 12 digit ordering code starting with 2306 or 2322. The next 5 digits indicate the resistor type and packaging see table 2.

The last 4 digits indicate the resistance value:

- The first 3 digits indicate the resistance value;
- The last digit indicates the resistance decade in accordance with table 3.

Example:

MRS16S, 750Ω, ±1%, ammopack 1000pcs is **2322 157 17501**.

NAFTA ORDERING INFORMATION

Table 4. NAFTA ordering code.

PRODUCT	TOLERANCE	NAFTA ORDERING CODE	TAPING	LEAD Ø	PACKAGING	QUANTITY (pcs)
MRS16S	±1%	5033MCxxxxxF08AF5	52.5 (2.07)	0.45 Cu (0.018)	AMMOPACK	1000
		5033MCxxxxxF18AF5			AMMOPACK	5000
		5033MCxxxxxF12AF5	REEL		5000	
		5033MCxxxxxF26M	26.0 (1.03)		AMMOPACK	5000
	±0.5%	5033MCxxxxxD08AF5	52.5 (2.07)	0.45 Cu (0.018)	AMMOPACK	1000
		5033MCxxxxxD18AF5			AMMOPACK	5000
		5033MCxxxxxD12AF5	REEL		5000	
		5033MCxxxxxD26M	26.0 (1.03)		AMMOPACK	5000
MRS25	±1%	5053MCxxxxxF08AF5	52.5 (2.07)	0.58 Cu (0.023)	AMMOPACK	1000
		5053MCxxxxxF18AF5			AMMOPACK	5000
		5053MCxxxxxF12AF5	REEL		5000	
		5053MCxxxxxF26M	26.0 (1.03)		AMMOPACK	4000
	±0.5%	5053MCxxxxxD08AF5	52.5 (2.07)	0.58 Cu (0.023)	AMMOPACK	1000
		5053MCxxxxxD18AF5			AMMOPACK	5000
		5053MCxxxxxD12AF5	REEL		5000	
		5053MCxxxxxD26M	26.0 (1.03)		AMMOPACK	4000
MRS25 Precision	±0.1%	5053MCxxxxxB08AF5	52.5 (2.07)	0.58 Cu (0.023)	AMMOPACK	1000
		5053MCxxxxxB18AF5			AMMOPACK	5000
		5053MCxxxxxB12AF5			REEL	5000

Dimensions unless specified in mm (inches)

Table 5. Examples of the ohmic value.

VALUE	5 DIGITS
1 Ω	1R000
10 Ω	10R00
100 Ω	100R0
1 kΩ	1K000
10 kΩ	10K00
100 kΩ	100K0
1 MΩ	1M000

The ohmic value in the NAFTA ordering code (see table 4) is represented by the “xxxxx” in the middle of the above ordering code. Table 5 gives some examples on how to use these 5 digits.

Example:

MRS16S, 1000Ω, ±1%, taping distance 52.5mm, ammopack 5000 pcs is **5033MC1K000F18AF5**

PACKAGING

TAPE IN AMMOPACK

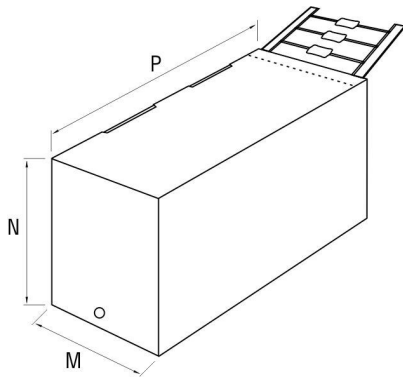

Table 6. Ammpack.

PRODUCT	TAPING	M	N	P	QUANTITY (pcs)
MRS16S	52.5 ±1.5 (2.07 ±0.06)	78 (3.1)	98 (3.9)	260 (10.3)	5000
		71 (2.8)	31 (1.3)	140 (5.6)	1000
	26.0 ±1.5 (1.03 ±0.06)	51 (2.1)	79 (3.2)	255 (10.1)	5000
MRS25 / MRS25 Precision	52.5 ±1.5 (2.07 ±0.06)	78 (3.1)	98 (3.9)	260 (10.3)	5000
		82 (3.3)	28 (1.2)	262 (10.4)	1000

Dimensions unless specified in mm (inches)

TAPE ON REEL

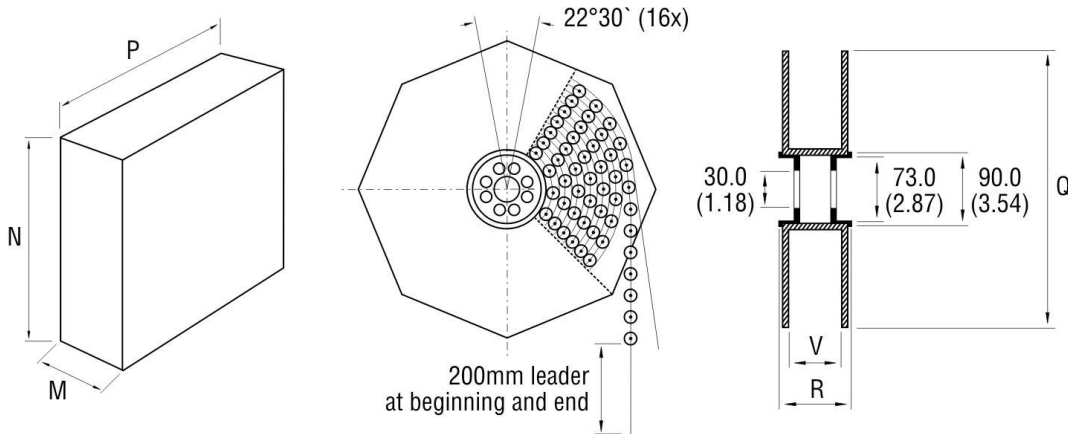

Table 7. Reel.

PRODUCT	TAPING	M	N	P	Q	V	R	QUANTITY (pcs)
MRS16S	52.5 ±1.5 (2.07 ±0.06)	92 (3.7)	273 (10.8)	273 (10.8)	267 (10.6)	75 (2.9)	86 (3.4)	5000
MRS25 / MRS25 Precision	52.5 ±1.5 (2.07 ±0.06)	92 (3.7)	311 (12.3)	311 (12.3)	305 (12.1)	75 (2.9)	86 (3.4)	5000

Dimensions unless specified in mm (inches)

TESTS AND REQUERIMENTS

Essentially all tests are carried out in accordance with the schedule of IEC publications 60115-1, category 55/155/56 (55/125/56 for MRS25 Precision); rated temperature range -55 to +155 °C (-55 to +125 °C for MRS25 Precision); damp heat, long term, 56 days and along the lines of IEC publications 60068-2; “Recommended basic climatic and mechanical robustness testing procedure for electronic components” and under standard atmosphere conditions according to IEC 60068-1 subclause 5.3, unless otherwise specified.

In some instances deviations from IEC applications were necessary for our specified method.

Table 8. Test and requirements.

IEC 60115-1 CLAUSE	IEC 60068-2 TEST METHOD	TEST	PROCEDURE	RESISTANCE RANGE	REQUIREMENTS
4.6.1.1	-	Insulation resistance	100 V (DC) for MRS16S and 500 V (DC) for MRS25/MRS25 Precision; during 1 minute; V-block method.	-	$R_{ins \min} 10^4 M\Omega$

MRS

IEC 60115-1 CLAUSE	IEC 60068-2 TEST METHOD	TEST	PROCEDURE	RESISTANCE RANGE	REQUIREMENTS
4.7	-	Voltage proof on insulation	400 V (RMS) for MRS16S, 600 V (RMS) for MRS25 Precision and 700 V (RMS) for MRS25; during 1 minute; V-block method.	-	No breakdown or flashover
4.8	-	Temperature coefficient	Between: - 55 °C and + 155 °C	MRS16S/MRS25	±50 ppm/°C
			- 55 °C and + 125 °C	MRS25 Precision	±25 ppm/°C
4.12	-	Noise	IEC publication 60195	MRS16S:	
				R ≤ 68 kΩ	≤ 0.1 μV/V
				R ≤ 100 kΩ	≤ 0.5 μV/V
				R > 100 kΩ	≤ 1.5 μV/V
				MRS25/ MRS25 Precision	
				R ≤ 1 MΩ	≤ 0.1 μV/V
			R > 1 MΩ	≤ 1.5 μV/V	
4.13	-	Short time overload	Room temperature; P = 6.25 x P _n ; 5 s ON and 45 s OFF (V ≤ 2 x V _{max}); 10 cycles	MRS16S/MRS25:	ΔR/R _{max} ±0.25% +0.05Ω
			Room temperature; P = 2.5 x P _n ; (V ≤ 2 x V _{max})	MRS25 Precision:	
				10Ω - 100Ω	ΔR/R _{max} ±0.05% +0.01Ω
				510kΩ - 560kΩ	
	101Ω - 505kΩ	ΔR/R _{max} ±0.02% +0.01Ω			
4.16	21(U)	Robustness of terminations:		No damage	
4.16.2	21(Ua1)	Tensile all samples	Load 5 N; 10 s	MRS16S/MRS25:	ΔR/R _{max} ±0.1% +0.05Ω
4.16.3	21(Ub)	Bending half number of samples	Load 2.5 N; 4 x 90°	MRS25 Precision:	
4.16.4	21(Uc)	Torsion other half of samples	3 x 360° in opposite directions	10Ω - 100Ω	ΔR/R _{max} ±0.05% +0.01Ω
				510kΩ - 560kΩ	
				101Ω - 505kΩ	ΔR/R _{max} ±0.02% +0.01Ω
4.17	20(Ta)	Solderability (after ageing)	16 h at 155 °C; leads immersed in flux 600, leads immersed 2 mm for 2 ±0.5 s in a solder bath at 235 ±5 °C	-	Good tinning (≥ 95% covered); no damage

IEC 60115-1 CLAUSE	IEC 60068-2 TEST METHOD	TEST	PROCEDURE	RESISTANCE RANGE	REQUIREMENTS			
4.18	20(Tb)	Resistance to soldering heat	Thermal shock 3 s; 350 °C; 6 mm from body; (260 ±5°C for MRS25 Precision)	MRS16S:				
				R≤100 kΩ	$\Delta R/R_{\max} \pm 0.1\% + 0.05\Omega$			
				R>100 kΩ	$\Delta R/R_{\max} \pm 0.25\% + 0.05\Omega$			
				MRS25:				
				$\Delta R/R_{\max} \pm 0.1\% + 0.05\Omega$				
				MRS25 Precision:				
				10Ω - 100Ω	$\Delta R/R_{\max} \pm 0.05\% + 0.01\Omega$			
510kΩ - 560kΩ								
4.19	14(Na)	Rapid change of temperature	30 minutes at - 55 °C and 30 minutes at + 155 °C (+125°C for MRS25 Precision); 5 cycles:	No visual damage				
				MRS16S:				
				R≤100 kΩ	$\Delta R/R_{\max} \pm 0.1\% + 0.05 \Omega$			
				R>100 kΩ	$\Delta R/R_{\max} \pm 0.25\% + 0.05 \Omega$			
				MRS25 / MRS25 Precision	$\Delta R/R_{\max} \pm 0.1\% + 0.05 \Omega$			
4.22	6(Fc)	Vibration	Frequency: 10 to 500 Hz, displacement 1.5 mm or acceleration 10 g, three directions; total 6 h (3x2 h)	No damage				
				MRS16S/MRS25	$\Delta R/R_{\max} \pm 0.1\% + 0.05 \Omega$			
				MRS25 Precision:				
				10Ω - 100Ω	$\Delta R/R_{\max} \pm 0.05\% + 0.01\Omega$			
				510kΩ - 560kΩ				
101Ω - 505kΩ	$\Delta R/R_{\max} \pm 0.02\% + 0.01\Omega$							
4.23	2(Ba)	Climatic sequence: Dry heat	16 h, + 155 °C (16 h, +125°C for MRS25 Precision)	$R_{\text{ins min}} 10^3 \text{ M}\Omega$				
4.23.2								
4.23.3						Damp heat (accelerated) 1 st cycle	24 h, 25 °C to 55 °C, 90% to 100% R.H.	
4.23.4						1(Aa)	Cold	2 h, - 55 °C
4.23.6						30(Db)	Damp heat (accelerated) remaining cycles	6 days; 25 °C to 55°C; 90 a 100% R.H.:
MRS16S								
R≤100 kΩ	$\Delta R/R_{\max} \pm 0.5\% + 0.05\Omega$							
R>100 kΩ	$\Delta R/R_{\max} \pm 1\% + 0.05\Omega$							
MRS25								
$\Delta R/R_{\max} \pm 0.5\% + 0.05\Omega$								
MRS25 Precision								
10Ω - 100Ω	$\Delta R/R_{\max} \pm 0.25\% + 0.01\Omega$							
510kΩ - 560kΩ								
101Ω - 505kΩ	$\Delta R/R_{\max} \pm 0.1\% + 0.01\Omega$							

MRS

IEC 60115-1 CLAUSE	IEC 60068-2 TEST METHOD	TEST	PROCEDURE	RESISTANCE RANGE	REQUIREMENTS
4.24	3(Ca)	Damp heat (steady state)	56 days; 40°C; 90 to 95% RH; loaded with 0.01 Pn	$R_{isol\ min} 10^3\ M\Omega$	
				MRS16S	
				$R \leq 100\ k\Omega$	$\Delta R/R_{max} \pm 0.5\% + 0.05\ \Omega$
				$R > 100\ k\Omega$	$\Delta R/R_{max} \pm 1\% + 0.05\ \Omega$
4.25.1	-	Endurance (at 70 °C)	1000 h; loaded with Pn or V_{max} ; 1.5 h ON and 0.5 h OFF	MRS16S	
				$R \leq 100\ k\Omega$	$\Delta R/R_{max} \pm 0.5\% + 0.05\ \Omega$
				$R > 100\ k\Omega$	$\Delta R/R_{max} \pm 1\% + 0.05\ \Omega$
				MRS25	$\Delta R/R_{max} \pm 0.5\% + 0.05\ \Omega$
4.25.3	-	Endurance at upper category temperature	1000 h at 155 °C (1000 h at 125°C for MRS25 Precision)	MRS16S	
				$R \leq 100\ k\Omega$	$\Delta R/R_{max} \pm 0.5\% + 0.05\ \Omega$
				$R > 100\ k\Omega$	$\Delta R/R_{max} \pm 1\% + 0.05\ \Omega$
				MRS25	$\Delta R/R_{max} \pm 0.5\% + 0.05\ \Omega$
4.29	45(Xa)	Component solvent resistance	Isopropyl alcohol followed by brushing in accordance with MIL STD 202	-	No visual damage
See 2 nd amendment to IEC 60115-1		Pulse load			See Figs. 7, 8, 9 and 10