

EVERBOUQUET INTERNATIONAL CO., LTD.

WE CATCH THE
BEST TECH. FOREVER

PART NO. : MC1604B-SBLW

FOR MESSRS. : _____

CONTENTS

<i>NO.</i>	<i>ITEM</i>	<i>PAGE</i>
1.	COVER	1
2.	RECORD OF REVISION	2
3.	GENERAL SPECIFICATION	3
4.	MECHANICAL DATA	3
5.	ABSOLUTE MAXIMUM RATINGS	4
6.	ELECTRICAL CHARACTERISTICS	5
7.	OPTICAL CHARACTERISTICS	5
8.	OUTLINE DIMENSION	6
9.	BLOCK DIAGRAM	7
10.	POWER SUPPLY	7



ACCEPTED BY : _____

PROPOSED BY : _____

RECORD OF REVISION

DATE	PAGE	SUMMARY
2002/10/03	5	Modify the Electrical characteristics (Power supply current for LED backlight) : (1) $V_{LED} : 5.0V \rightarrow 4.0V$ (2) $I_{LED} (TYP.) : 60\text{ mA} \rightarrow 45\text{ mA}$ (3) $I_{LED} (MAX.) : 90\text{ mA} \rightarrow 60\text{ mA}$
2002/10/03	7	Modify the Power supply for LCM

3. General specifications

3.1 General specifications

PLEASE REFER TO:

“CUSTOMER ACCEPTANCE STANDARD SPECIFICATIONS (MS-10-12780)”.

3.2 This individual specification is prior to general specifications

4. Mechanical data

- (1) NUMBER OF CHARACTER----- 16 CH * 4 LINE
- (2) MODULE SIZE----- 87.0 W * 60.0 H * 15.0 T (Max) mm
- (3) EFFECTIVE AREA ----- 61.8 W * 25.2 H mm
- (4) CHARACTER PATTERN----- 5 * 7 DOTS + CURSOR
- (5) CHARACTER SIZE ----- 2.96 W * 4.16 H mm
- (6) CHARACTER PITCH ----- 3.55 mm
- (7) DOT SIZE----- 0.56 W * 0.56 H mm
- (8) DOT PITCH ----- 0.60 W * 0.60 H mm
- (9) VIEWING DIRECTION----- 6 O’CLOCK
- (10) LCD TYPE ----- STN.BLUE.TRANSMISSIVE.
- (11) LED BACKLIGHT COLOR ----- WHITE

5. Absolute maximum ratings

5.1 Electrical absolute maximum ratings

<i>I T E M</i>	<i>SYMBOL</i>	<i>MIN.</i>	<i>MAX.</i>	<i>UNIT</i>	<i>COMMENT</i>
POWER SUPPLY FOR LOGIC	V _{DD} -V _{SS}	0	6.0	V	-----
INPUT VOLTAGE	V _I	V _{SS}	V _{DD}	V	-----
STATIC ELECTRICITY	-----	-----	100	V	NOTE (1)
POWER SUPPLY FOR LED BACKLIGHT	V _{LED}	-----	6.0	V	-----

NOTE (1): ELECTRO-STATIC DISCHARGE RESISTANCE IS TESTED BY CHARGING A 200PF CAPACITOR AND DISCHARGING IT BY CONTACT WITH A INTERFACE CONNECTOR PIN.

5.2 Environmental absolute maximum ratings

<i>I T E M</i>	<i>OPERATING</i>		<i>STORAGE</i>		<i>COMMENT</i>
	<i>MIN.</i>	<i>MAX.</i>	<i>MIN.</i>	<i>MAX.</i>	
AMBIENT TEMPERATURE	0°C	50°C	-20°C	70°C	-----
HUMIDITY	NOTE (2)		NOTE (2)		NO CONDENSATION
VIBRATION NOTE (3)	-----	0.5G	-----	2G	10~300Hz XYZ DIRECTIONS 1 Hr EACH
SHOCK NOTE (3)	-----	3G	-----	50G	10 msec XYZ DIRECTIONS 1 TIME EACH
CORROSIVE GAS	NOT ACCEPTABLE		NOT ACCEPTABLE		-----

NOTE (2) : Ta ≤ 50°C: 90% RH MAX.

Ta > 50°C: ABSOLUTE HUMIDITY MUST BE LOWER THAN THE HUMIDITY OF 90% RH AT 50°C. (80% RH AT 60°C)

NOTE (3): 1G = 9.8 m/s²

6. Electrical characteristics

$T_a = 25^\circ\text{C}$ $V_{DD} = 5.0 \pm 0.25\text{ V}$

<i>I T E M</i>	<i>SYMBOL</i>	<i>CONDITION</i>	<i>MIN.</i>	<i>TYP.</i>	<i>MAX.</i>	<i>UNIT</i>	
INPUT VOLTAGE	V_{IH}	-----	2.2	-----	-----	V	
	V_{IL}	-----	-----	-----	0.6	V	
OUTPUT VOLTAGE	V_{OH}	$-I_{OH} = 0.2\text{ mA}$	2.4	-----	-----	V	
	V_{OL}	$I_{OH} = 1.2\text{ mA}$	-----	-----	0.4	V	
POWER SUPPLY CURRENT	I_{DD}	$V_{DD} = 5.0\text{ V}$	-----	1.5	2.0	mA	
RECOMMENDED LCD DRIVING VOLTAGE	$V_{DD}-V_O$	DUTY =1/16 $\varnothing=10^\circ$	$T_a=0^\circ\text{C}$	-----	4.7	-----	V
			$T_a=25^\circ\text{C}$	-----	4.5	-----	V
			$T_a=50^\circ\text{C}$	-----	4.3	-----	V
POWER SUPPLY CURRENT FOR LED BACKLIGHT	I_{LED}	$V_{LED} = 4.0\text{V}$ \triangle	-----	45 \triangle	60 \triangle	mA	

NOTE (1): RECOMMENDED LCD DRIVING VOLTAGE MAY FLUCTUATE ABOUT $\pm 0.5\text{V}$ BY EACH MODULE.

7. Optical characteristics

$T_a = 25^\circ\text{C}$ $V_{DD}-V_O = 4.5\text{V}$

<i>I T E M</i>	<i>SYMBOL</i>	<i>CONDITION</i>	<i>MIN.</i>	<i>TYP.</i>	<i>MAX.</i>	<i>UNIT</i>	<i>NOTE</i>
VIEWING ANGLE	$\Phi 2-\Phi 1$	$K = 2.0$ $\theta = 0^\circ$	30	40	-----	deg.	1
CONTRAST RATIO	K	$\Phi = 10^\circ$ $\theta = 0^\circ$	4	5	-----	-----	1
RESPONSE TIME	tr (rise)	$\Phi = 10^\circ$ $\theta = 0^\circ$	-----	200	350	ms	1
	tf (fall)	$\Phi = 10^\circ$ $\theta = 0^\circ$	-----	300	400	ms	1
BRIGHTNESS FOR LED BACKLIGHT	B	$\Phi = 0^\circ$ $\theta = 0^\circ$	6.0	-----	-----	cd/m^2	1,2

NOTE (1): SEE CUSTOMER ACCEPTANCE STANDARD SPECIFICATION FOR DEFINITION OF OPTICAL CHARACTERISTICS.

NOTE (2): UNDER NORMAL TEMPERATURE AND HUMIDITY IN A DARK ROOM.

8. Outline dimension

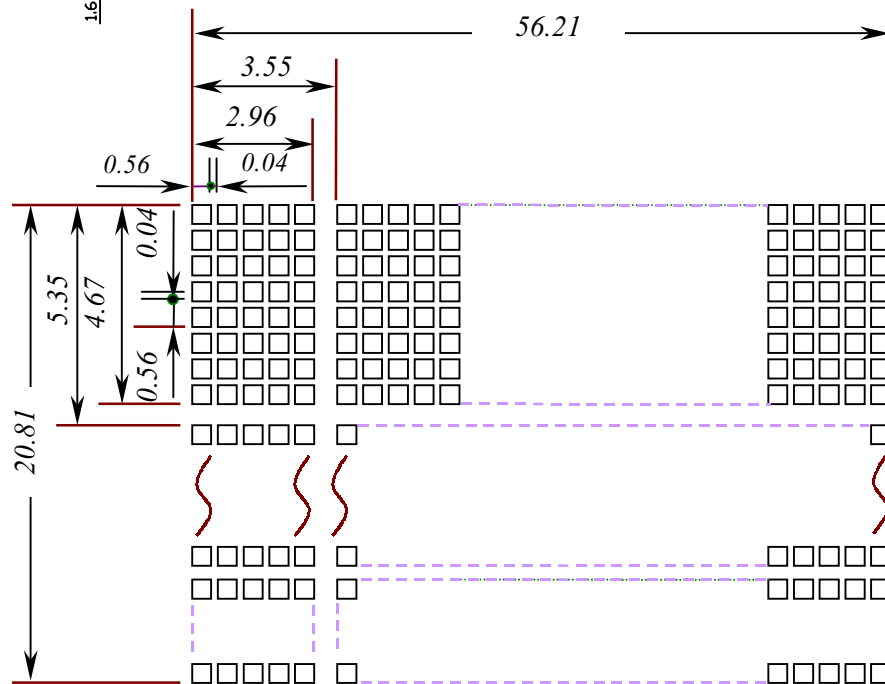
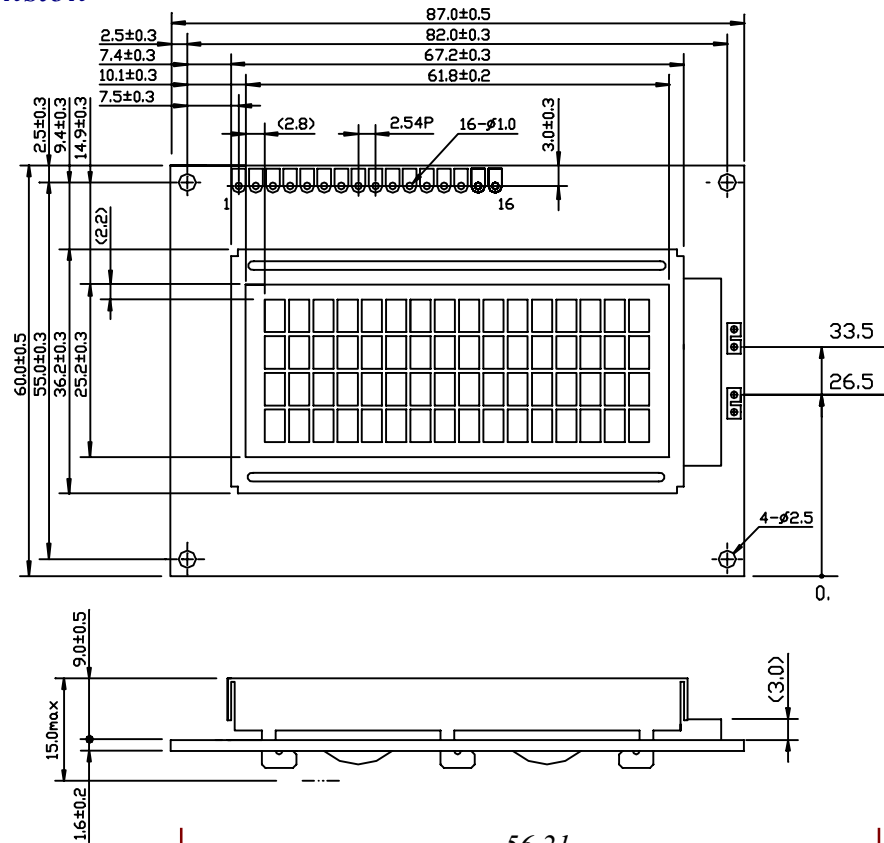

單位：mm

SCALE：NTS

Interface pin connection

PIN NO.	1	2	3	4	5	6	7	8
SYMBOL	V _{SS}	V _{DD}	V _O	RS	R/W	E	DB0	DB1
PIN NO.	9	10	11	12	13	14	15	16
SYMBOL	DB2	DB3	DB4	DB5	DB6	DB7	A	K

9 Block diagram

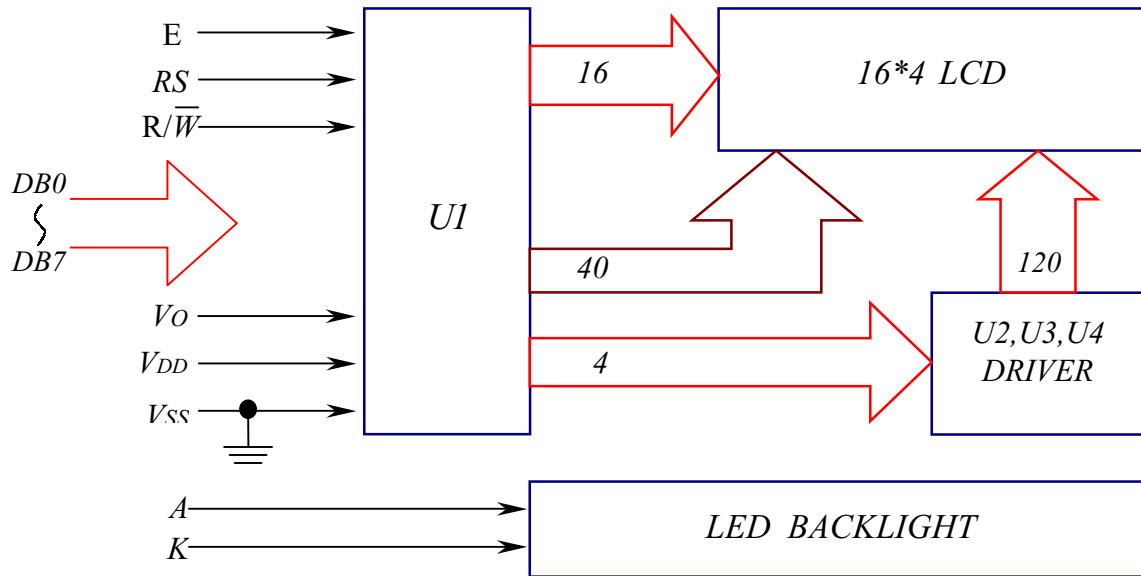

Display data address charts

Character	1	2	3	4	5	6	7	8	9	10	11	12	13	14	15	16
LINE 1	00	01	02	03	04	05	06	07	08	09	0A	0B	0C	0D	0E	0F
LINE 2	40	41	42	43	44	45	46	47	48	49	4A	4B	4C	4D	4E	4F
LINE 3	10	11	12	13	14	15	16	17	18	19	1A	1B	1C	1D	1E	1F
LINE 4	50	51	52	53	54	55	56	57	58	59	5A	5B	5C	5D	5E	5F

10. Power supply for LCM

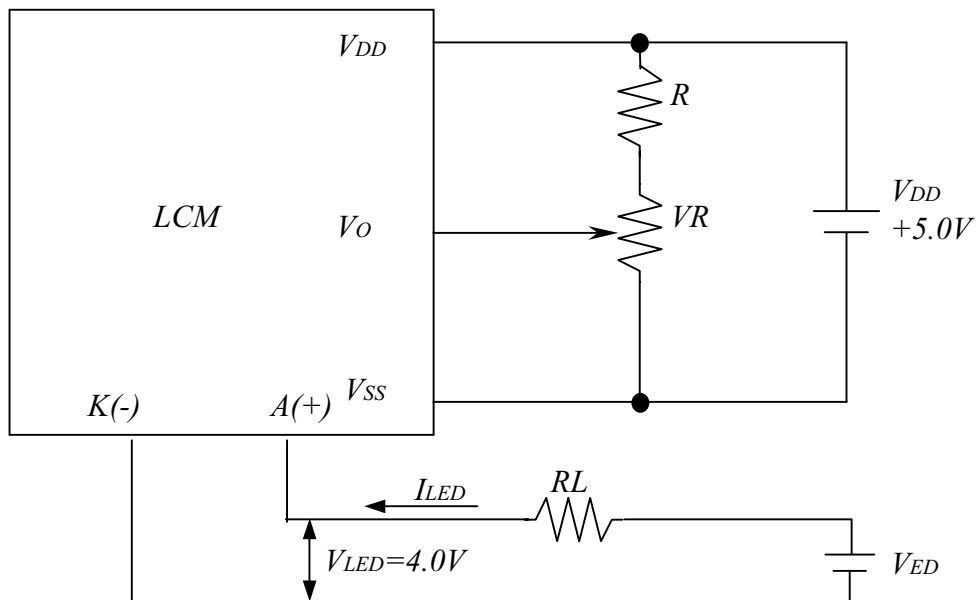

RECOMMENDED RESISTOR R: $V_{DD} - V_o \geq 1.5V$

$R_L \geq ((V_{ED} - 4.0V) / I_{LED})$, $I_{LED} \leq 60mA$

$V_{DD} - V_o$: LCD DRIVING VOLTAGE

VR: $10K\Omega \sim 20K\Omega$