



WE CATCH THE
BEST TECH. FOREVER

EVERBOUQUET INTERNATIONAL CO., LTD.

PART NO. : MC16011A8-SERIES

FOR MESSRS. : _____

CONTENTS

<i>NO.</i>	<i>ITEM</i>	<i>PAGE</i>
1.	COVER	1
2.	RECORD OF REVERSION	2
3.	GENERAL SPECIFICATION	3
4.	MECHANICAL DATA	4
5.	ABSOLUTE MAXIMUM RATINGS	5
6.	ELECTRICAL CHARACTERISTICS	6
7.	OPTICAL CHARACTERISTICS	7
8.	OUTLINE DIMENSION	8
9.	BLOCK DIAGRAM	9
10.	POWER SUPPLY FOR LCM	10

ACCEPTED BY: _____

PROPOSED BY : _____



RECORD OF REVISION

DATE	PAGE	SUMMARY

3. General specifications

3.1 General specifications

PLEASE REFER TO:

“CUSTOMER ACCEPTANCE STANDARD SPECIFICATIONS (MS-10-0069)”

3.2 This individual specification is prior to general specifications

3.3 NUMBERING SYSTEM

MC16011A

B	W
---	---

 8-

S	Y	M	L	W	U	N
---	---	---	---	---	---	---

(1) (2) (3) (4) (5) (6) (7) (8) (9)

(1).CHARACTER FONTS :

PLEASE REFER TO

“CUSTOMER ACCEPTANCE STANDARD SPECIFICATIONS (MS-10-0069)”

(2).LCM TEMPERATURE :

“nil” : NORMAL TEMP

“W” : WIDE TEMP

(3).LCD TYPE :

“T” : TN TYPE

“S” : STN TYPE

“H” : HTN TYPE

“F” : FSTN TYPE

(4).LCD COLOR :

“Y” : YELLOW-GREEN “B” : BLUE(STN/NEGATIVE)/BLACK(FSTN/NEGATIVE)

“G” : GRAY “W” : WHITE(FSTN/POSITIVE)

(5).LCD POLARIZE TYPE

“nil” : TRANSFLECTIVE

“M” : TRANSMISSIVE

(6).BACKLIGHT TYPE :

“L” : LED BACKLIGHT

(7).BACKLIGHT COLOR :

LED TYPE :

“nil” : YELLOW-GREEN

“A” : AMBER

“B” : BLUE

“G” : PURE GREEN

“O” : ORANGE

“R” : RED

“W” : WHITE

(8).VIEWING DIRECTION :

“nil” : 6 O’CLOCK

“3” : 3 O’CLOCK

“U” : 12 O’CLOCK

“9” : 9 O’CLOCK

(9).BACKLIGHT TYPE :

“nil” : LED(+),LED(-)---NORMAL

“N” : LED(+),LED(-)---CHANGE

4. Mechanical data

- (1) NUMBER OF CHARACTER ----- 16 CH * 1 LINE
- (2) MODULE SIZE -----80.0 W * 36.0 H * 10.0 T (max) mm
- (3) EFFECTIVE AREA -----64.5 W * 16.0 H mm
- (4) CHARACTER PATTERN -----5 * 7 DOTS + CURSOR
- (5) CHARACTER SIZE-----3.07 W *5.73 H mm
- (6) CHARACTER PITCH -----3.77 mm
- (7) DOTS SIZE-----0.55 W * 0.75 H mm
- (8) DOTS PITCH-----0.63 W * 0.83 H mm

5. Absolute maximum ratings

5.1 Electrical absolute maximum ratings

<i>I T E M</i>	<i>SYMBOL</i>	<i>MIN.</i>	<i>MAX.</i>	<i>UNIT</i>	<i>COMMENT</i>
POWER SUPPLY FOR LOGIC	V _{DD} -V _{SS}	0	6.0	V	-----
INPUT VOLTAGE	V _I	V _{SS}	V _{DD}	V	-----
STATIC ELECTRICITY	-----	-----	100	V	NOTE (1)
POWER SUPPLY FOR LED	V _{LED}	-----	NOTE(2)	V	-----

NOTE (1): ELECTRO-STATIC DISCHARGE RESISTANCE IS TESTED BY CHARGING A 200PF CAPACITOR AND DISCHARGING IT BY CONTACT WITH A INTERFACE CONNECTOR PIN.

NOTE (2):

<i>SYMBOL</i>	<i>V_{LED} MAX.</i>	<i>LED TYPE</i>
V _{LED}	5.5V	YELLOW-GREEN,AMBER,ORANGE,RED
	5.0V	BLUE,PURE GREEN,WHITE

5.2 Environmental absolute maximum ratings

<i>I T E M</i>	<i>CONDITION</i>	<i>OPERATING</i>		<i>STORAGE</i>		<i>COMMENT</i>
		<i>MIN.</i>	<i>MAX.</i>	<i>MIN.</i>	<i>MAX.</i>	
AMBIENT TEMPERATURE	NORMAL	0	50	-20	70	-----
	WIDE	-20	70			
HUMIDITY	-----	NOTE (2)		NOTE (2)		NO CONDENSATION
VIBRATION NOTE (3)	-----	-----	0.5G	-----	2G	10~300Hz XYZ DIRECTIONS 1 Hr EACH
SHOCK NOTE (3)	-----	-----	3G	-----	50G	10 msec XYZ DIRECTIONS 1 TIME EACH
CORROSIVE GAS	-----	NOT ACCEPTABLE		NOT ACCEPTABLE		-----

NOTE (2): Ta = 50 : 90% RH MAX.

Ta > 50 : ABSOLUTE HUMIDITY MUST BE LOWER THAN THE HUMIDITY OF 90% RH AT 50 . (80%RH AT 60)

NOTE (3): 1G = 9.8 m/s²

6. Electrical characteristics

$T_a = 25$

$V_{DD} = 5.0 \pm 0.25 V$

<i>I T E M</i>	<i>SYMBOL</i>	<i>CONDITION</i>	<i>MIN.</i>	<i>TYP.</i>	<i>MAX.</i>	<i>UNIT</i>	
INPUT VOLTAGE	V_{IH}	-----	2.2	-----	-----	V	
	V_{IL}		-----	-----	0.6	V	
OUTPUT VOLTAGE	V_{OH}	$-I_{OH} = 0.205 \text{ mA}$	2.4	-----	-----	V	
	V_{OL}	$I_{OL} = 1.2 \text{ mA}$	-----	-----	0.4	V	
POWER SUPPLY CURRENT	I_{DD}	$V_{DD} = 5.0V$	-----	1.0	1.5	mA	
RECOMMENDED LCD DRIVING VOLTAGE, NOTE(1)	$V_{DD} - V_O$	STN/ FSTN DUTY =1/16 =10° NOTE(2)	$T_a = -20^\circ\text{C}$	-----	4.8	-----	V
			$T_a = 0^\circ\text{C}$	-----	4.7	-----	V
			$T_a = 25^\circ\text{C}$	-----	4.5	-----	V
			$T_a = 50^\circ\text{C}$	-----	4.3	-----	V
			$T_a = 70^\circ\text{C}$	-----	4.2	-----	V
		TN DUTY =1/16 =25° NOTE(2)	$T_a = -20^\circ\text{C}$	-----	4.7	-----	V
			$T_a = 0^\circ\text{C}$	-----	4.6	-----	V
			$T_a = 25^\circ\text{C}$	-----	4.2	-----	V
			$T_a = 50^\circ\text{C}$	-----	3.8	-----	V
			$T_a = 70^\circ\text{C}$	-----	3.7	-----	V
POWER SUPPLY CURRENT FOR NOTE(3)	I_{LED}	V_{LED} NOTE(3)	-----	30	40	mA	

NOTE (1): RECOMMENDED LCD DRIVING VOLTAGE MAY FLUCTUATE ABOUT $\pm 0.5V$ BY EACH MODULE.

(2): $= 0^\circ$: VIEWING ANGLE AT 6 O'CLOCK
 $= 180^\circ$: VIEWING ANGLE AT 12 O'CLOCK

(3): LED CURRENT OF DIFFERENT LED TYPE

<i>LED B.L TYPE</i>	V_{LED}	I_{LED}				<i>LED COLOR</i>
		<i>MIN.</i>	<i>TYP.</i>	<i>MAX.</i>	<i>UNIT.</i>	
A	4.8V	-----	30	40	mA	YELLOW-GREEN, AMBER, ORANGE, RED
B	4.0V	-----	30	40	mA	BLUE, WHITE, PURE GREEN

7. Optical characteristics

TN TYPE LCD

 $T_a = 25$
 $V_{DD}-V_O = 4.2V$

<i>I T E M</i>	<i>SYMBOL</i>	<i>CONDITION</i>	<i>MIN.</i>	<i>TYP.</i>	<i>MAX.</i>	<i>UNIT</i>	<i>NOTE</i>
VIEWING ANGLE	2- 1	K = 1.4 NOTE(1)	20	30	----	deg.	NOTE(2)
CONTRAST RATIO	K	= 25° NOTE(1)	2.0	3.0	----	----	NOTE(2)
RESPONSE TIME	tr (rise)	= 25° NOTE(1)	----	150	250	ms	NOTE(2)
	tf (fall)	= 25° NOTE(1)	----	150	250	ms	NOTE(2)

STN TYPE LCD

 $T_a = 25$
 $V_{DD}-V_O = 4.5V$

<i>I T E M</i>	<i>SYMBOL</i>	<i>CONDITION</i>	<i>MIN.</i>	<i>TYP.</i>	<i>MAX.</i>	<i>UNIT</i>	<i>NOTE</i>
VIEWING ANGLE	2- 1	K = 2.0 NOTE(1)	30	40	----	deg.	NOTE(2)
CONTRAST RATIO	K	= 10° NOTE(1)	3.0	4.0	----	----	NOTE(2)
RESPONSE TIME	tr (rise)	= 10° NOTE(1)	----	200	350	ms	NOTE(2)
	tf (fall)	= 10° NOTE(1)	----	300	400	ms	NOTE(2)

FSTN /STN BLUE TYPE LCD

 $T_a = 25$
 $V_{DD}-V_O = 4.5V$

<i>I T E M</i>	<i>SYMBOL</i>	<i>CONDITION</i>	<i>MIN.</i>	<i>TYP.</i>	<i>MAX.</i>	<i>UNIT</i>	<i>NOTE</i>
VIEWING ANGLE	2- 1	K = 2.0 NOTE(1)	30	40	----	deg.	NOTE(2)
CONTRAST RATIO	K	= 10° NOTE(1)	4.0	5.0	----	----	NOTE(2)
RESPONSE TIME	tr (rise)	= 10° NOTE(1)	----	200	350	ms	NOTE(2)
	tf (fall)	= 10° NOTE(1)	----	300	400	ms	NOTE(2)

Brightness for LED backlight

<i>SYMBOL</i>	<i>CONDITION</i>	<i>MIN.</i>	<i>TYP.</i>	<i>MAX.</i>	<i>UNIT</i>	<i>LED TYPE</i>	<i>NOTE</i>
B	= 0°	4.0	----	----	cd/m ²	YELLOW-GREEN, RED, AMBER, ORANGE	NOTE(2)
	= 0°	6.0	----	----		BLUE, PURE GREEN, WHITE	NOTE(3)

NOTE (1): = 0° WHEN VIEWING ANGLE AT 6 O'CLOCK
= 180° WHEN VIEWING ANGLE AT 12 O'CLOCK

(2): SEE CUSTOMER ACCEPTANCE STANDARD SPECIFICATION FOR DEFINITION OF OPTICAL CHARACTERISTICS.

(3): UNDER NORMAL TEMPERATURE AND HUMIDITY IN A DARK ROOM.

8. Outline dimension

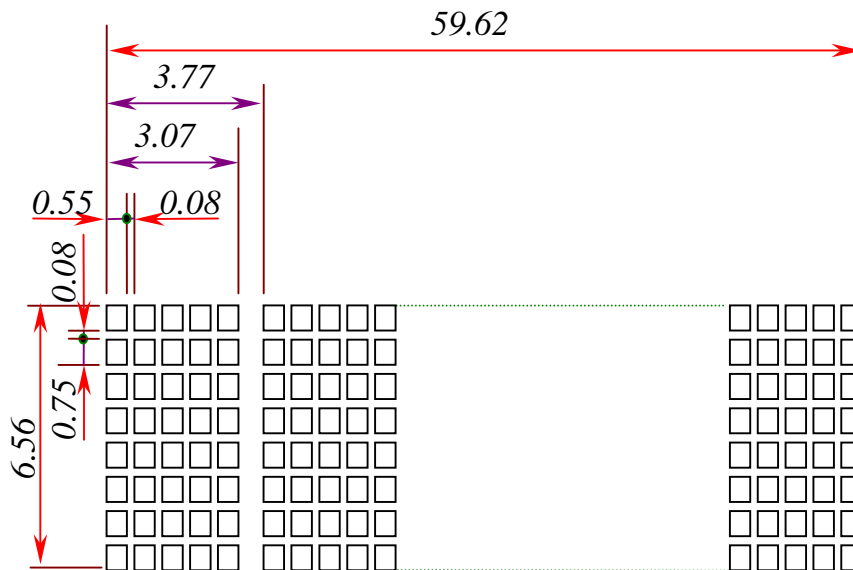
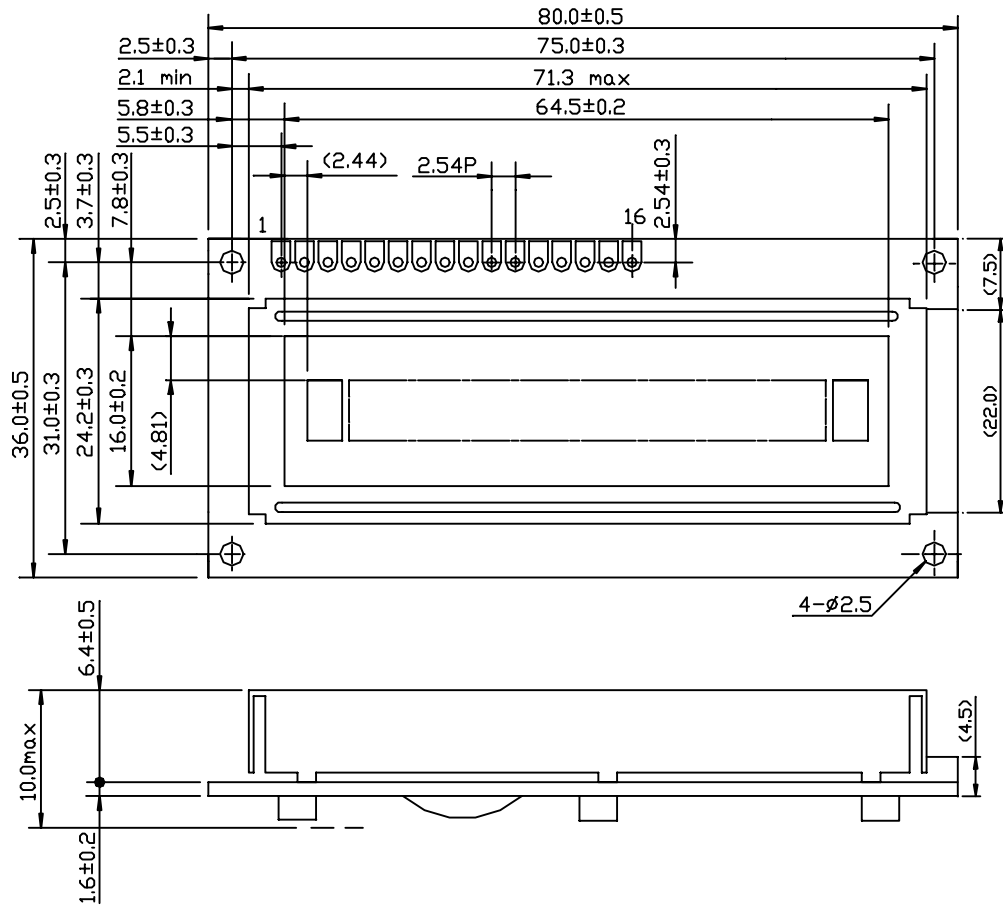

NOTE :
 1.UNIT : mm
 2.SCALE : NTS

Interface pin connection

PIN NO.	1	2	3	4	5	6	7	8
SYMBOL	V _{SS}	V _{DD}	V _O	RS	R/W	E	DB0	DB1
PIN NO.	9	10	11	12	13	14	15	16
SYMBOL	DB2	DB3	DB4	DB5	DB6	DB7	A(+)	K(-)

9. Block diagram

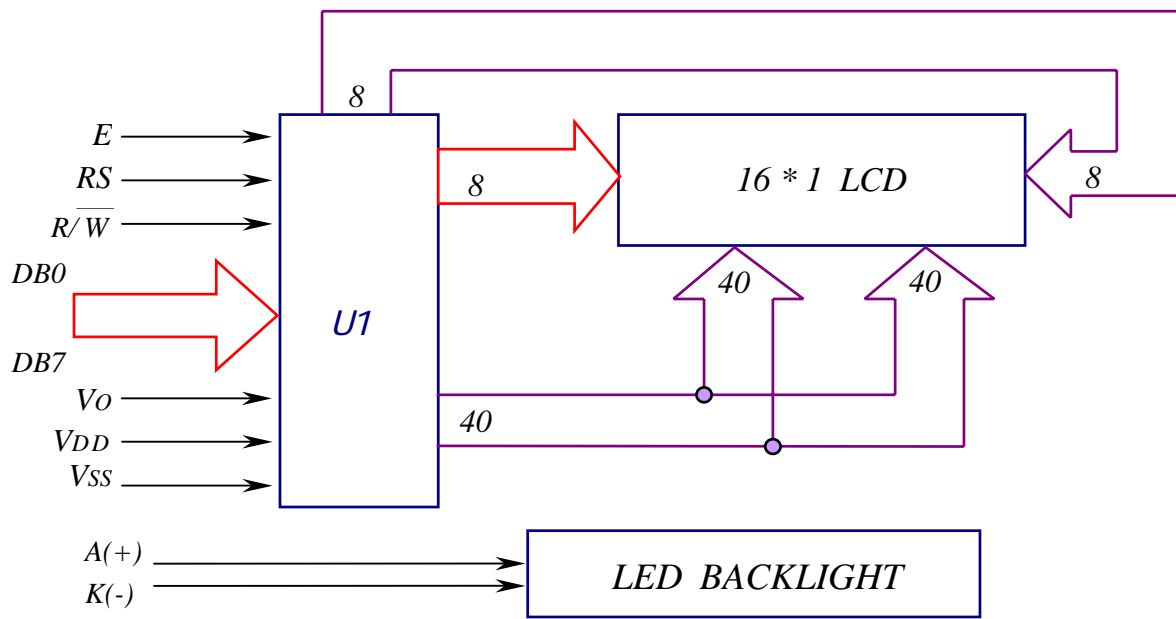

Display data address charts

	1	2	3	4	5	6	7	8	9	10	11	12	13	14	15	16
LINE 1	00	01	02	03	04	05	06	07	40	41	42	43	44	45	46	47

10. Power supply for LCM

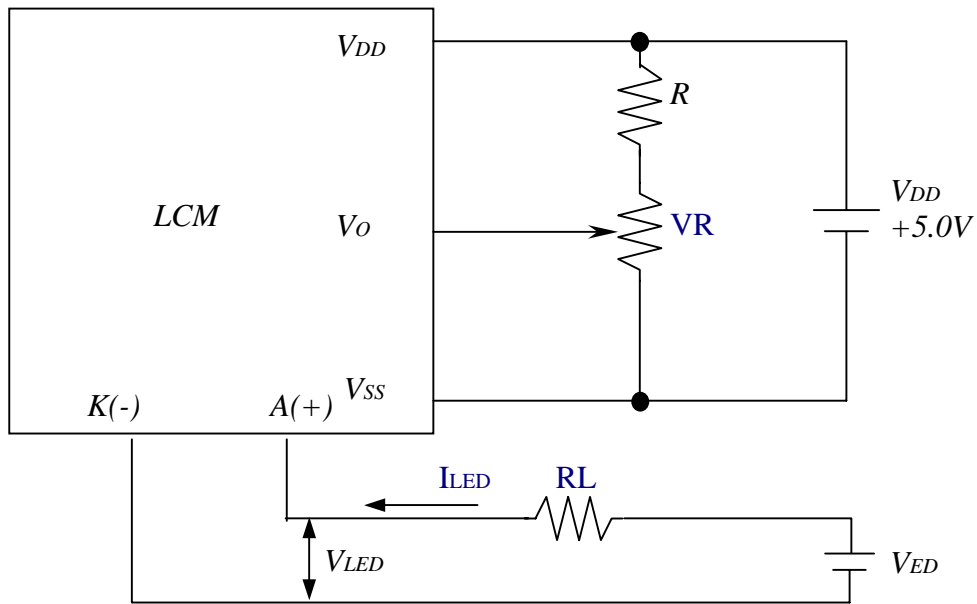

RECOMMENDED RESISTOR R : $V_{DD}-V_o$ 1.5V

$V_{DD}-V_o$: LCD DRIVING VOLTAGE

VR: 10K ~20K

<i>ITEM</i>	<i>LED TYPE</i>	<i>CONDITION</i>
Limit resistor of LED (RL)	A	$RL = ((V_{ED}-4.8V) / I_{LED})$, $I_{LED} = 40mA$
	B	$RL = ((V_{ED}-4.0V) / I_{LED})$, $I_{LED} = 40mA$