

4-20 mA – Modbus Smart Sensor Connectivity Kit

4-20 mA Process Signals

What is 4-20 mA

- A very common means to connect 'field devices' (Sensors) to control and monitoring equipment
- Devices are often referred to as **field transmitters** and include:
 - Temperature, Pressure, Strain, Ultrasonic, Level, Flow, pH and many others
- Common in **Intrinsically Safe** applications where sensor measurement is isolated from the detection system.
- The current flowing in the circuit, referred to as the *Loop Current* will vary between 4 and 20 mA, determined by the measured value
- If the current is less than 4 mA or greater than 20 mA indicates an **error condition**
- The mA signal is typically **scaled** to represent engineering units, for example, for an ultrasonic Depth measurement:
 - 4 mA == 10 feet depth
 - 20 mA == 100 feet depth

Advantages of 4-20 mA

- Less sensitive to electrical noise
- Integrated broken wire detection (0 mA)
- Long range transmission

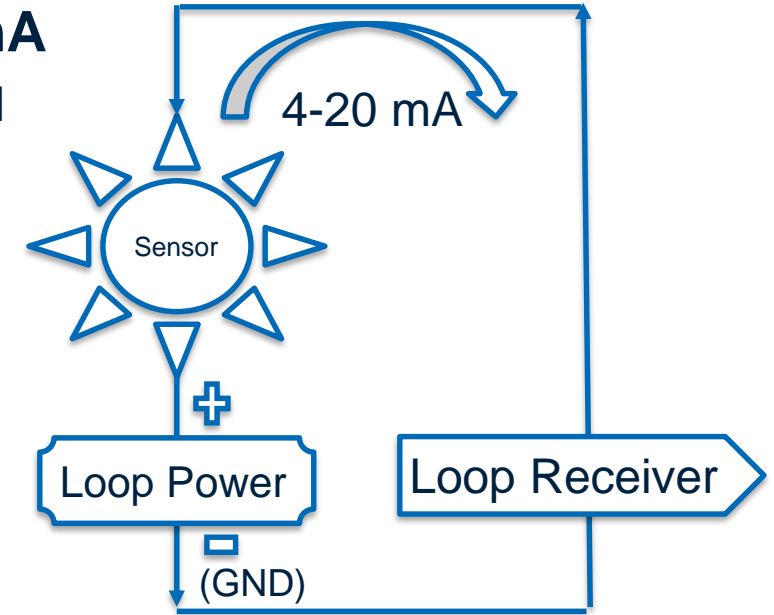

- **Loop Power:** Provides 'excitation' voltage to the sensor, typically 12 – 24 Vdc
- **Sensor:** Controls the current that flows thru the circuit based on the measured value
- **Loop Receiver:** Converts the 4-20 mA signal and displays or transmits the measured value

4-20 mA – Modbus Smart Sensor Connectivity Kit

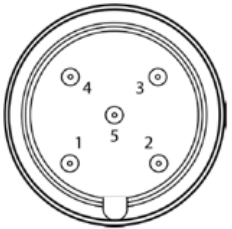

Pin	Connection
1	3.3 Vdc (not used)
2	4-20 mA Process Signal 0 (Positive)
3	GND (4-20 mA Common)
4	4-20 mA Process Signal 1 (Positive)
5	4-20 mA Process Signal 2 (Positive)

- **PSU-93** → Provides Excitation current
- **M12.5-S-M-FM** → 5 pin Screw Terminal connector
- **SP-014-1** → 4-20 mA to Smart Sensor digital interface
- **IF-002** → Smart Sensor to Modbus conversion
- **M12.5-B-S-M-FM** → 5 pin Screw Terminal connector (B type)
- **SP-014** Supports up to 3 external 4-20 Process Signals
- **IF-002** Supports up to 32 devices on RS485 Serial Channel

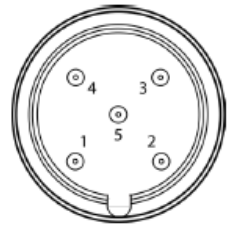

Pin	Connection
1	Bus Power (5-36 Vdc)
2	RS485 Data + (A')
3	GND
4	RS485 Data – (B')
5	SHIELD

4-20 mA Process Signals - Scaling

- External 4-20 mA signal conveys information in terms of mA, which represent some other 'unit of measure'
 - Level Sensor Example: 4 mA == 10 ft of water, 20 mA == 100 ft of water or 4 mA == 0% full, 20 mA = 100% full
- Smart Sensor allows linear **scaling** of measurement for **unit** conversion using simple $y = Mx + B$ formula, where M is the 'gain' and B is an offset.
 - Determine Gain: $(Actual_Hi - Actual_Lo) / (Reading_Hi - Reading_Lo) == (100 - 0) / (20 - 4) == 6.25$
 - Determine Offset: use calculated Gain, with 0 as Actual == $0 - 6.25 * 4 == -25$
 - Change the 'units' string to %

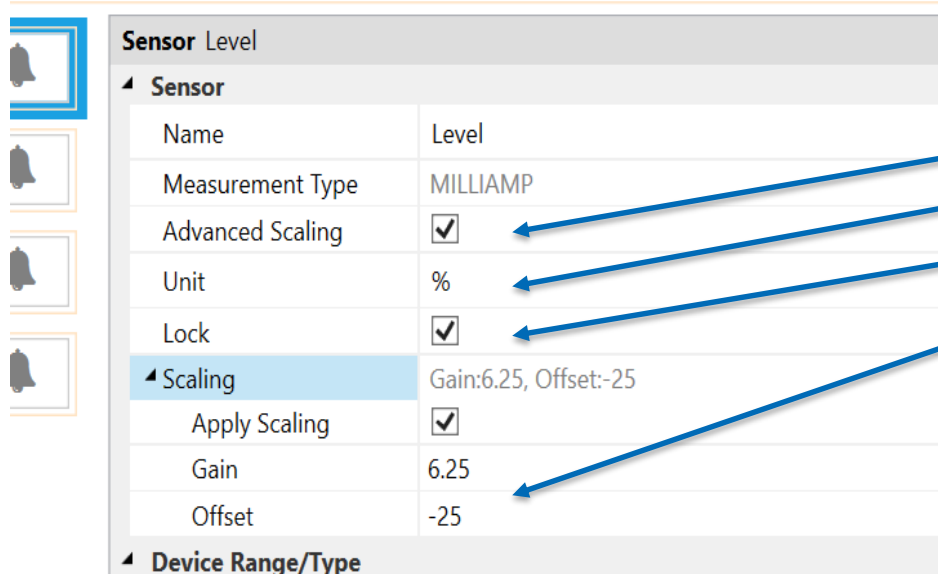

Sensor Level	
▲ Sensor	
Name	Level
Measurement Type	MILLIAMP
Advanced Scaling	<input checked="" type="checkbox"/>
Unit	%
Lock	<input checked="" type="checkbox"/>
▲ Scaling	Gain:6.25, Offset:-25
Apply Scaling	<input checked="" type="checkbox"/>
Gain	6.25
Offset	-25
▲ Device Range/Type	

Advanced Scaling option opens the scaling options
Change **unit** to any string (maximum 4 characters)
Ensure **lock** option is set (retains across power reset)
Enter calculated **Gain** and **Offset** values

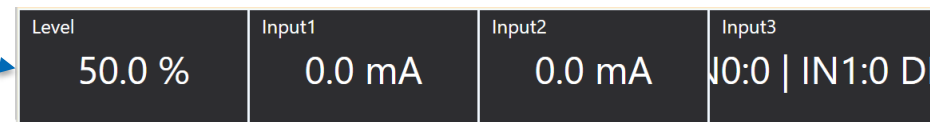

Level	Input1	Input2	Input3
50.0 %	0.0 mA	0.0 mA	J0:0 IN1:0 DI