

Type: **P1-32/I2**
 Article No.: **207320**



Ordering information

Design			Surface mounting
Description			Without auxiliary contacts
Main conducting paths No. of poles		M	3
Auxiliary contacts		N/O	0
Auxiliary contacts		B	0
Max. three-phase motor rating (per set of 3 contacts) 50-60 Hz AC-3 400/415 V 50-60 Hz	<i>P</i>	kW	15
Rated uninterrupted current	<i>I_u</i>	A	32

Contact sequence

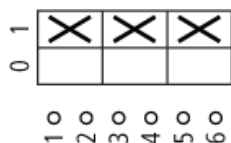

General

Standards			IEC/EN 60947, VDE 0660, IEC/EN 60204, CSA, UL Switch-disconnectors to IEC/EN 60947-3
Lifespan, mechanical	Operations	$\times 10^6$	0,3
Maximum operating frequency	Operations/h		50

Climatic proofing			Damp heat, constant, to IEC 60068-2-78; Damp heat, cyclical, to IEC 60068-2-30
Ambient temperature			
Open		° C	--25/50
Enclosed		° C	--25/40
Mounting position			As required
Documentation			Main catalogue HPL
Mechanical shock resistance (shock duration 20 ms)		g	> 15

Contacts

Rated operational voltage	U_e	V AC	690
Rated impulse withstand voltage	U_{imp}	V AC	6000
Overvoltage category/pollution degree			III/3
Rated uninterrupted current			
open	I_u	A	25
Enclosed	I_u	A	25
Load-carrying capacity in intermittent operation, Class 12			
AB 25 % DF		$\times I_e$	2
AB 40 % DF		$\times I_e$	1,6
AB 60 % DF		$\times I_e$	1,3
Short-circuit rating			
Fuse		A gG/gL	25
Rated short-time withstand current (1 s current)	I_{cw}	A_{rms}	640
Switching angles		°	90
Current heat loss per contact at I_e		W	1,1

Terminal capacities

Solid or stranded		mm ²	1 × (1.5 – 6) 2 × (1.5 – 6)
Flexible with ferrule to DIN 46228		mm ²	1 × (1 – 4) 2 × (1 – 4)
Terminal screw			M4
Tightening torque		Nm	1.6

Switching capacity

AC			
Rated making capacity $\cos \phi = 0.35$		A	240
Rated breaking capacity, motor load switch $\cos \phi = 0.35$			

230 V		A	190
400 V		A	150
500 V		A	170
690 V		A	150
Rated operational current 440 V load-break switch AC-21A	I_e	A	25
AC-3 motor load switch motor rating			
230 V	P	kW	5,5
400 V	P	kW	7,5
500 V	P	kW	7,5
690 V	P	kW	7,5
AC-23A Motor load switches (main switches maintenance switches)			
230 V	P	kW	7
400 V	P	kW	13
500 V	P	kW	11
690 V	P	kW	11
DC			
DC-1, Load-break switches L/R = 1 ms			
Rated operational current	I_e	A	25
Voltage per contact pair in series		V	60
DC-23A, Motor load switches L/R = 15 ms			
24 V			
Rated operational current	I_e	A	25
Contacts		Quantity	1
48 V			
Rated operational current	I_e	A	25
Contacts		Quantity	2
60 V			
Rated operational current	I_e	A	25
Contacts		Quantity	3
120 V			
Rated operational current	I_e	A	12
Contacts		Quantity	3
Notes			

		<p>Main switch characteristics to IEC/EN 60204; positive opening of contacts, operator element positively located on shaft</p> <p>The rated uninterrupted current I_u is stated at max. connected cross-section.</p> <p>For terminal capacity solid, stranded and flexible: Max. 2 cross-section sizes difference admissible when using 2 conductors.</p>
--	--	--

Dimensions

Explanation		<p>For utilisation category AC-4 (extreme load: 100 % inching, reversing or plugging)</p> <p>The blocked rotor current of the motor should not exceed the rated current of the switch for AC-21A to ensure a reasonable device lifespan.</p>
-------------	--	--

Dimensions

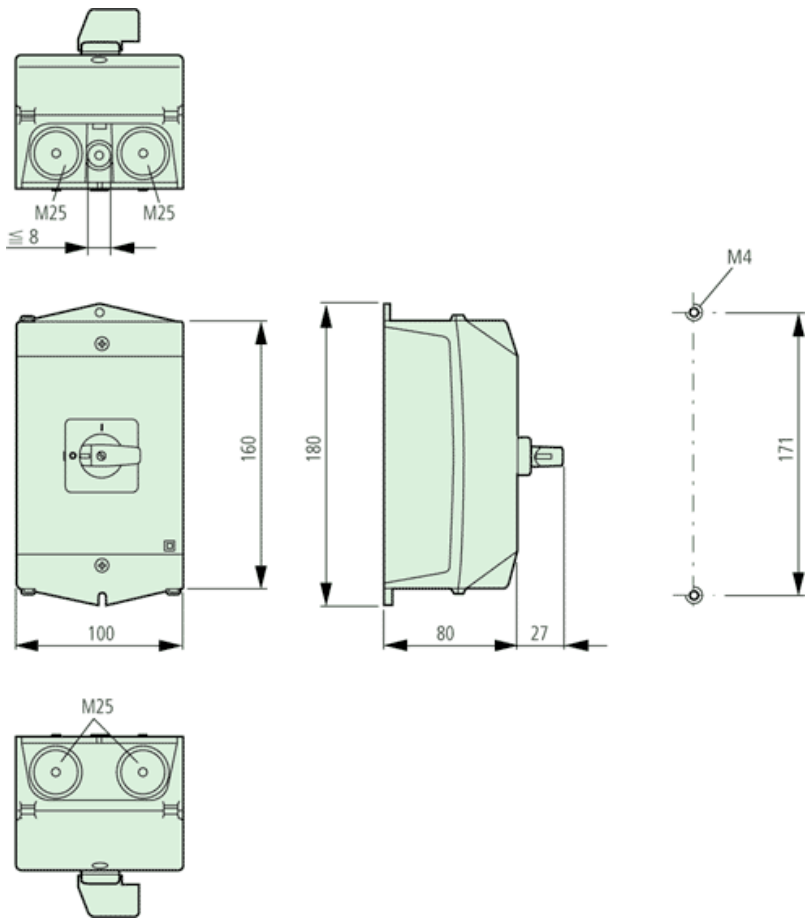

Dimensions

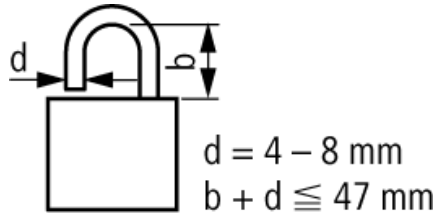

Characteristic curve

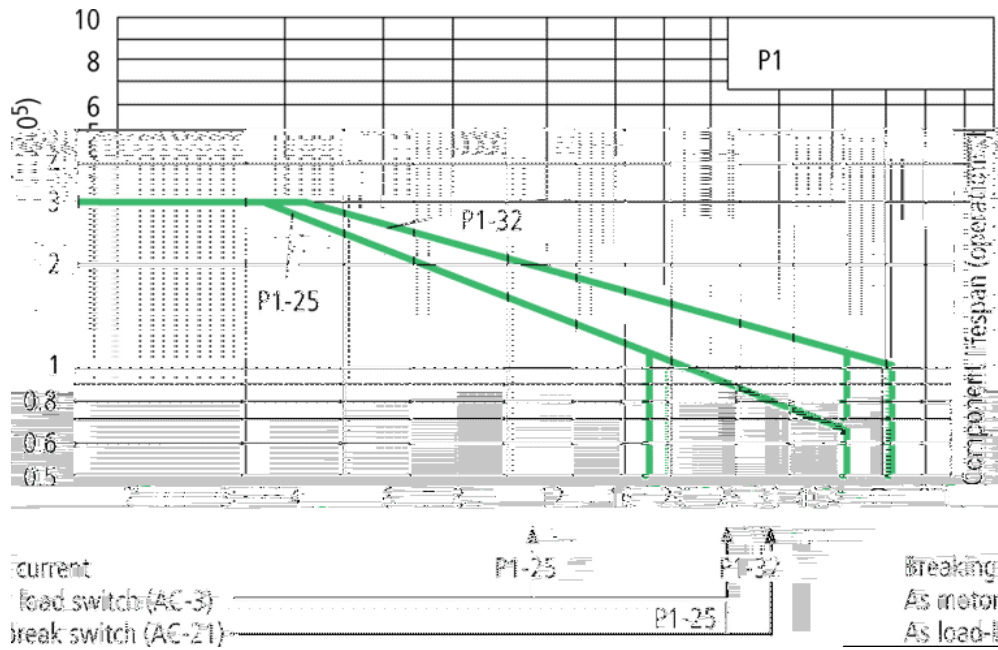

Moeller GmbH, Hein-Moeller-Str. 7-11, D-53115 Bonn
 E-Mail: catalog@moeller.net, Internet: www.moeller.net, <http://catalog.moeller.net>
 Copyright 2006 by Moeller GmbH. Subject to modifications. HPL-C2006GB-INT V2.3