

120W AC to DC Power Supply - DIN Rail Mount

multicomp PRO

**RoHS
Compliant**



Features

- PFC Function Available
- Parallel Function Available (Switch)
- Input Voltage 115/230V AC Auto Select
- Selv Components Design



Model List

Model No.	Input Voltage	Output Wattage	Output Voltage	Output Current	EFF. (Min.)	EFF. (Typ.)
Single Output Models						
MP-DRAN120-12A	115 / 230 V AC	120 WATTS	+ 12 V DC	10A	82%	84%
MP-DRAN120-48A			+ 48 V DC	2.5A	85%	87%

Specification

All Specifications Typical At Nominal Line, Full Load, 25°C Unless Otherwise Noticed

General						
Characteristics	Conditions	Min.	Typ.	Max.	Unit	
Switching Frequency	Vi nom, Io nom		55		kHz	
Isolation Voltage	Input - Output	3,000 / 4,242			V AC / V DC	
	Input-FG	1,500 / 2,121			V AC / V DC	
	Output-FG	500 / 710			V AC / V DC	
Isolation Resistance	Input- Output, @ 500V DC	100			MΩ	
Ambient Temperature	Operating at Vi nom	-35		+ 71	°C	
Derating (see Derating curve)	Vi nom, from +61°C to +71°C			2.5	% / °C	
Storage Temperature	Non operational	-40		+ 85	°C	
Relative Humidity	Vi nom, Io nom	20		95	% RH	
Temperature Coefficient	Vi nom, Io min			± 0.03	% / °C	
MTBF	Bellcore Issue 6 @40°C, GB 12V 24V AL / BL 48V			509,000	Hours	
				530,000		
				659,000		
				600,000		
Altitude During Operation	EN 60950-1			5,000	m	
Dimension	Screw terminal type	L124.5 × W64 × D123.6			mm	
	Detachable connector type	L143.5 × W64 × D123.6				
Cooling	Free air convection					
Installation Position	Vertical (other direction may derating using)					
Pollution Degree		2				

Newark.com/multicomp-pro
Farnell.com/multicomp-pro
Element14.com/multicomp-pro

multicomp PRO

120W AC to DC Power Supply

- DIN Rail Mount

multicomp PRO

Input Specifications					
Characteristics	Conditions	Min.	Typ.	Max.	Unit
Rated input voltage	Io nom	115 / 230 (auto select)			V AC
Absolute input max. Range	Ta min ... Ta max, AC in 115V selected	90		132	V AC
	Io nom AC in 230V selected	180		264	V AC
	DC in	210		375	V DC
Input Current	Vi : 115 / 230 V AC, Io nom AL, BL models		2.2 / 0.83 1.65 / 0.65		A
Rated input Current	Vi : 90 / 180 V AC, Io nom AL, BL models			2.8 / 104 2 / 0.8	A
Line Frequency	Vi nom, Io nom	47		63	Hz
Inrush current	Vi : 115 / 230 V AC , Io nom			24 / 48	A
Power dissipation	Vi : 230 V AC, Io nom	12V	24		W
		24V	20		
		AL / BL	16		
		48V	19		
Leakage Current	Input-Output			0.25	mA
	Input-FG			3.5	mA
Power factor (Passive)	Vi : 230V AC, Io nom		0.75		

Output Specifications

Characteristics	Conditions	Min.	Typ.	Max.	Unit
Output voltage accuracy (Adjusted before shipment)	Vi nom, Io max	0		+ 1	%
Minimum Load	Vi nom	0			%
Line Regulation	Io nom, Vi min ...Vi max			± 0.5	%
Load Regulation	Vi nom, single mode			± 1	%
	Io min ...Io nom parallel mode			± 5	%
Voltage trim Range	Vi nom, 0.8 Io nom	12V	11.4	14.5	V DC
		24V	22.5	28.5	
		AL / BL	22.5	24.5	
		48V	45	55	
Rated continuous loading	Vi nom	12V 24V AL / BL 48V	10 A @ 12V DC / 8.2 A @ 14.5 V DC 5 A @ 24V DC / 4.2 A @ 28.5 V DC 3.8 A @ 24V DC / 3.7 A @ 24.5 V DC 2.5 A @ 48V DC / 2.1 A @ 55 V DC		
Hold up Time	Vi : 115 / 230 V AC , Io nom	25 / 30			ms
Turn on Time	Vi nom, Io nom			1,000	ms
	Vi nom, Io nom 12V model : with 7000µF CAP 24V, 48V models : with 3500µF CAP			1,500	ms
Rise Time	Vi nom, Io nom			150	ms
	Vi nom, Io nom 12V model : with 7000µF CAP 24V, 48V models : with 3500µF CAP			150 500	ms
Fall Time	Vi nom, Io nom			150	ms
Transient Recovery Time	Vi nom, 1 to 0.5 Io nom			2	ms

Newark.com/multicomp-pro
Farnell.com/multicomp-pro
Element14.com/multicomp-pro

multicomp PRO

120W AC to DC Power Supply - DIN Rail Mount

multicomp PRO

Characteristics	Conditions	Min.	Typ.	Max.	Unit
Ripple & Noise	Vi nom, Io nom, BW = 20MHz			50	mV
Power Back Immunity	Vi nom, Io nom	12V	18		V DC
		24V	35		
		48V	63		
Capacitor Load	Vi nom, Io nom	12V		7,000	µF
		24V, 48V		3,500	
DC ON indicator Threshold at start up (Green LED)	Vi nom, Io nom	12V	10	11.2	V DC
		24V	17.6	19.4	
		48V	37	43	
DC LOW Indicator Threshold after start up (Red LED)	Vi nom, Io nom	12V	10	11.2	V DC
		24V	17.6	19.4	
		48V	37	43	
Parallel operation	0.1 Io min to 0.9 Io max (Except AL / BL models)			3	unit
Efficiency	Vi nom, Io nom, Po / Pi	Up to 87%, See model list and type efficiency curve			

Control and Protection					
Characteristics	Conditions	Min.	Typ.	Max.	Unit
Input fuse		T3.15A / 250V AC internal			
Internal surge voltage protection	IEC 61000-4-5	Varistor			
Rated over load protection	Vi nom (see typ current limited curve)	110		145	%
	AL / BL	102		108	
Power Rdy (for 24V model only)	Threshold voltage of contact closed(at start up)	17.6		19.4	V DC
	Electrical isolation	500			V DC
	Contact rating at 60V DC			0.3	A
Over voltage protection	Vi nom, 0.8 Io nom (Auto Recovery)	12V	15	16.8	V
		24V	30	33	
		48V	60	66	
Output short circuit		Fold forward			
Degree of protection		IP20			

Approvals and Standards	
UL / cUL	UL 508 Listed UL 60950-1, UL 1310 Class 2 Power (24AL/BL models only) Recognized ISA 12.12.01(Class I, Division 2, Groups A, B, C and D)
TUV	EN 60950-1 EN 61558-1, EN 61558-2-16 (meet EN 60204-1)
CE	EN 61000-6-3, EN 55032 Class B, EN 61000-3-2 Class D, EN 61000-3-3 EN 61000-6-2, EN 55024, EN 61000-4-2 Level 4, EN 61000-4-3 Level 3 EN 61000-4-4 Level 4, EN 61000-4-5 L-N Level 3, L / N-FG Level 4 EN 61000-4-6 Level 3, EN 61000-4-8 Level 4, EN 61000-4-11 ENV 50204 Level 2, EN 61204-3
CCC	GB4943.1, GB9254, GB17625.1
Vibration resistance	Meet IEC 60068-2-6 (Mounting on rail : 10-500 Hz, 2G, along X, Y, Z each Axis, 60 min for each Axis)
Shock resistance	Meet IEC 60068-2-27 (15G, 11ms, 3 Axis, 6 Faces, 3 times for each Face)

Newark.com/multicomp-pro
Farnell.com/multicomp-pro
Element14.com/multicomp-pro

multicomp PRO

120W AC to DC Power Supply - DIN Rail Mount

multicomp PRO

Physical Characteristics

Case size	Screw terminal type	124.5mm × 64mm × 123.6mm (4.9 inches × 2.52 inches × 4.87 inches)
Case material	Metal	
Weight	920g	

Mechanism & Pin Configuration

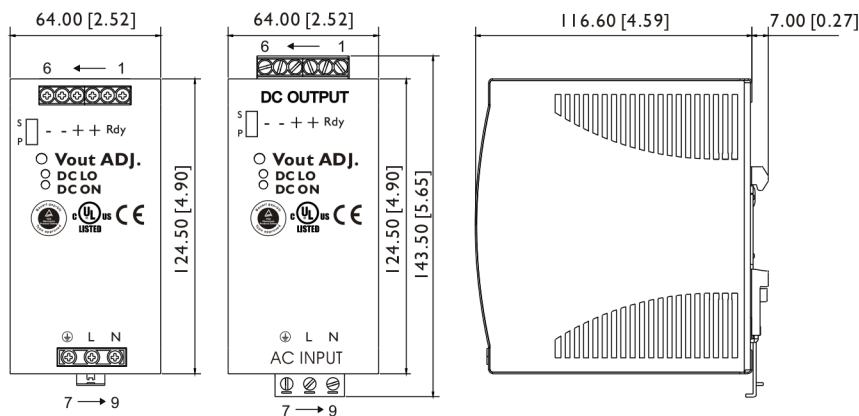

Construction

Easy snap-on mounting onto the DIN-Rail (TS35/7.5 or TS35/15), unit sits safely and firmly on the rail.

Installation

Ventilation / Cooling Normal convection

All sides 25mm free space For cooling recommended Connector size range

Screw terminal:

AWG24-10 (0.2~4mm²) flexible / solid cable,

-Input connector can withstand torque at maximum 9 pound-inches.

-Output connector can withstand torque at maximum 5.5 pound-inches.

8 m/m stripping at cable end recommends

Use copper conductors only 60°C / 75°C

General Tolerance

0[0.00] - 30[1.18]	±0.3[0.01]
30[1.18] - 120[4.72]	±0.5[0.02]
120[4.72] - 400[15.75]	±0.8[0.03]

Pin Assignment

PIN NO.	Designation	Description
1	OUT	RDY
2		A normal open circuit of PhotoMOS Relay (24V model only)
3, 4		V +
5, 6		V -
7	IN	⊕
8		Ground this terminal to minimize high-frequency emissions
9		L
	OTHER	N
		DC ON
		Operation indicator LED
		DC LO
	DC LOW voltage indicator LED	
	Vout ACJ.	Trimmer-potentiometer for Vout adjustment
	S/P	Single / Parallel select switch

Newark.com/multicomp-pro
Farnell.com/multicomp-pro
Element14.com/multicomp-pro

multicomp PRO

120W AC to DC Power Supply - DIN Rail Mount

multicomp PRO

Circuit Schematic

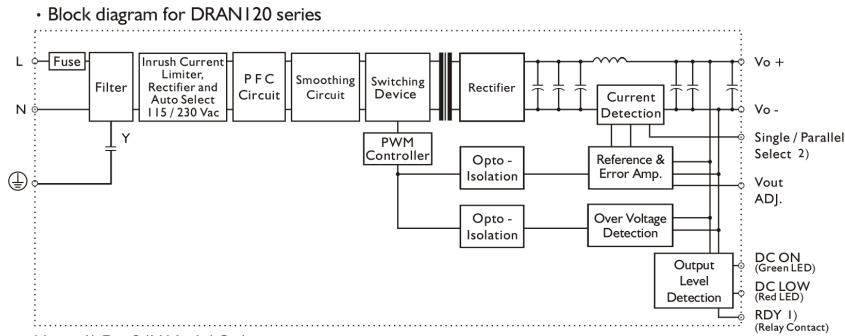

Type Current Limited Curve

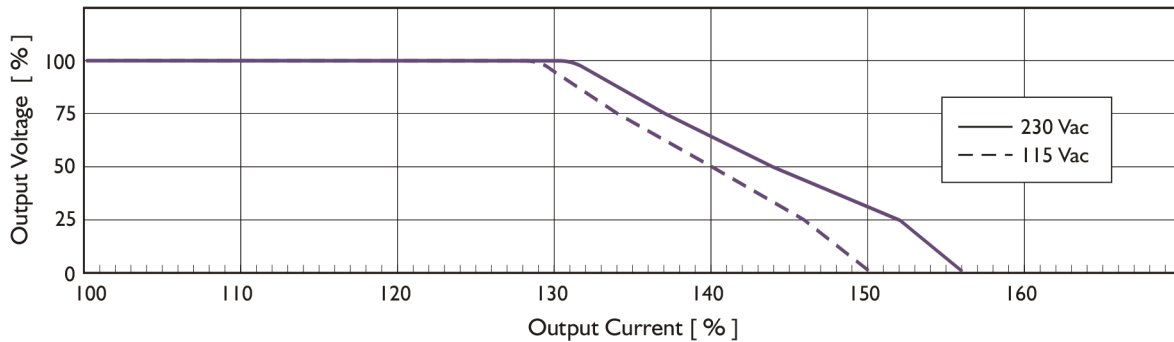

Derating Curve

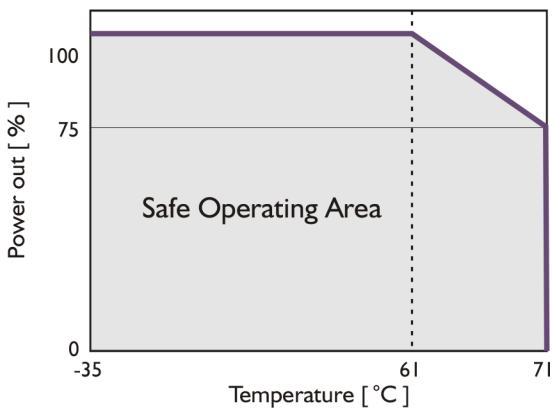

Type Efficiency Curve

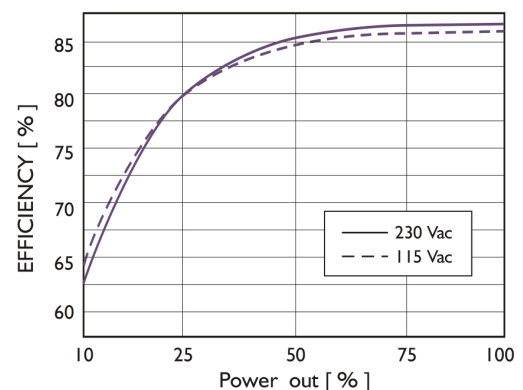

Important Notice : This data sheet and its contents (the "Information") belong to the members of the AVNET group of companies (the "Group") or are licensed to it. No licence is granted for the use of it other than for information purposes in connection with the products to which it relates. No licence of any intellectual property rights is granted. The Information is subject to change without notice and replaces all data sheets previously supplied. The Information supplied is believed to be accurate but the Group assumes no responsibility for its accuracy or completeness, any error in or omission from it or for any use made of it. Users of this data sheet should check for themselves the Information and the suitability of the products for their purpose and not make any assumptions based on information included or omitted. Liability for loss or damage resulting from any reliance on the Information or use of it (including liability resulting from negligence or where the Group was aware of the possibility of such loss or damage arising) is excluded. This will not operate to limit or restrict the Group's liability for death or personal injury resulting from its negligence. Multicomp Pro is the registered trademark of Premier Farnell Limited 2019.

Newark.com/multicomp-pro
Farnell.com/multicomp-pro
Element14.com/multicomp-pro

multicomp PRO