

## General Specifications

Motor Type: DC Brushless Motor

Motor Protection: Auto Restart/Polarity Protection

Motor withstands reverse connection for positive and negative leads.

Insulation Resistance:

10M  $\Omega$  or over with a DC500V Megger

Dielectric Withstand Voltage:

AC 700V 1s or 500V 1min

Allowable Ambient Temperature Range:

-10°C ~ +70°C (Operating)

-40°C ~ +70°C (Storage)

(non-condensing environment)

## Characteristics Curves

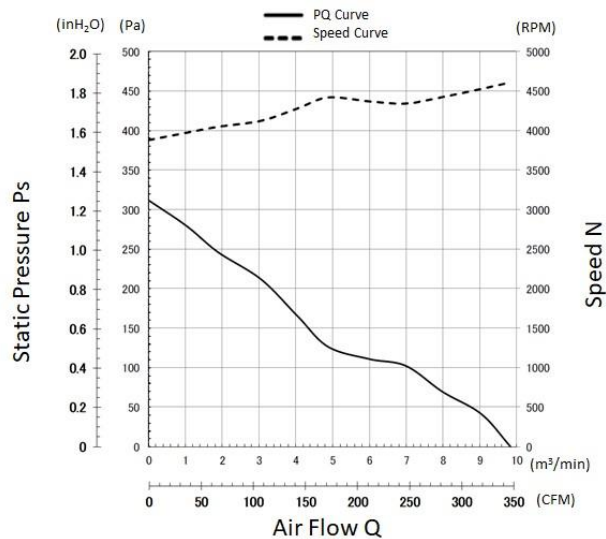

## PWM Benefits & Applications

### PWM Benefits

- Increased Life Expectancy
- Energy Saving
- Lower Vibration
- Lower Noise
- Current Spike Prevention

### PWM Applications

- Routers
- Switches
- Storage
- Data Centers
- Optical Repeaters
- Broadcast Equipment
- Inverters
- UPS
- Battery Chargers
- Fuel Cells
- Industrial Power Supplies
- Welders
- Plasma Cutters
- Instrumentation
- Test Equipment
- Enclosures and more

- Customized fan performances at multiple operating points.
- Peak efficiency resulting in lower total ownership costs.
- Cost effective and better reliability.

## Life Expectancy L10

25°C 100,000 Hours

## Specifications

MODEL	Rated Voltage	Operating Voltage	Current		Input Power		Speed	Max. Air Flow		Max. Static Pressure		Noise	Mass
	(V)	(V)	Avg	Max	Avg	Max	(min <sup>-1</sup> ) <sup>1</sup>	(CFM) <sup>1</sup>	(m <sup>3</sup> /min) <sup>1</sup>	(inH <sub>2</sub> O) <sup>1</sup>	(Pa) <sup>1</sup>	(dB) <sup>1</sup>	(g)
	(V)	(V)	(A) <sup>1</sup>	(A) <sup>1</sup>	(W) <sup>1</sup>	(W) <sup>1</sup>	(min <sup>-1</sup> ) <sup>1</sup>	(CFM) <sup>1</sup>	(m <sup>3</sup> /min) <sup>1</sup>	(inH <sub>2</sub> O) <sup>1</sup>	(Pa) <sup>1</sup>	(dB) <sup>1</sup>	(g)
17250VA-48R-EU-01	48	38.0 ~ 52.8	0.90	1.10	43.20	52.80	4600	346.1	9.80	1.25	312	62.0	830

\*1: Maximum Values in Free Air

## PWM Specifications

### PWM CONTROL

#### ● CONNECTION

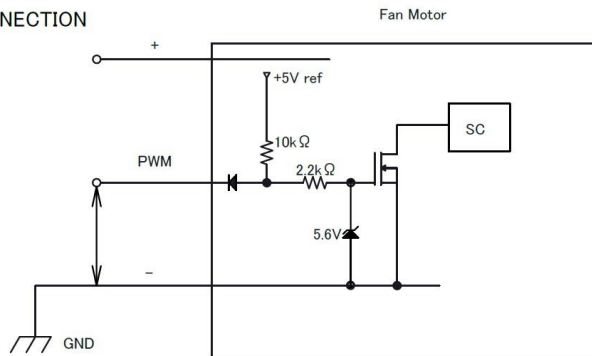

#### 1. Vst : PWM CONTROL VOLTAGE

- Vst = Low Level (0V ~ 0.4V) → Stop (On Duty 0%)
- Vst = High Level (3.3V ~ 5.0V) → Full Speed (On Duty 100%)
- Vst = Open → Full Speed

#### 2. PWM Duty & PWM Input Pulse

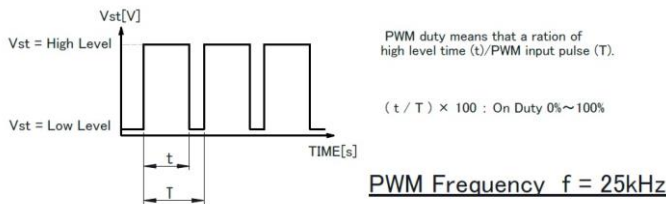

## PWM Characteristics Curve

### REFERENCE PWM Duty VS Speed

Conditions : at rating voltage, Vst(H)=5.0V, f=25kHz, Ta=25°C

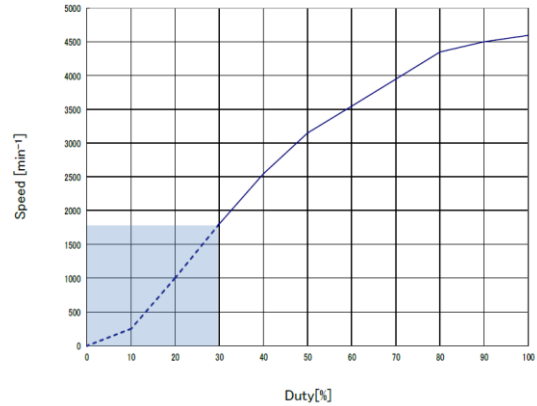

#### 3. The condition for PWM control are as follows.

- In case of PWM control, it is suggested to confirm the operation of fan installed inside the system. Fan Motor may not start up caused by PWM control at very Low Speed Condition.
- To run at Rating Voltage.
- Please use the start with Duty 30% or more at 25kHz. [At rated voltage input, Ambient temperature 25°C]

## TACHO Specifications

### TACHO SIGNAL

1. OUTPUT CIRCUIT : OPEN COLLECTOR
2. SPECIFICATION
  - Ta=25°C
  - Absolute Maximum Ratings at Ta=25°C
  - V<sub>CE</sub> max : +52.8V
  - I<sub>C</sub> max : 5mA [V<sub>CE(sat)</sub>max = 2V]

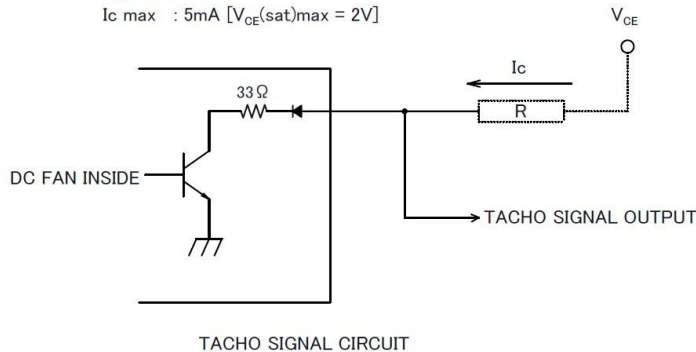

### 3. OUTPUT WAVEFORM : AT RATED VOLTAGE

#### OUTPUT SIGNAL VOLTAGE

3-1 Case-1

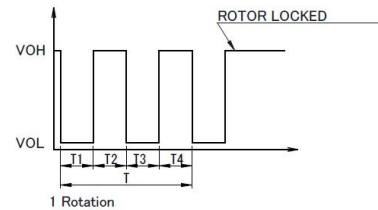

3-2 Case-2

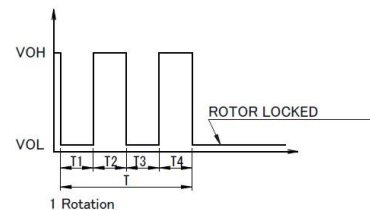

- 1) When the rotor is locked at VOH position of signal, signal keeps VOH position.
- 2) When the rotor is locked at VOL position of signal, signal keeps VOL position.
- 3)  $T = T1 + T2 + T3 + T4 = 60 / m = 1 \text{ rotation}$   
 $m : \text{min}^{-1}$   
 Tach Duty Cycle = 50% ± 10%

## Panel Cut-Outs

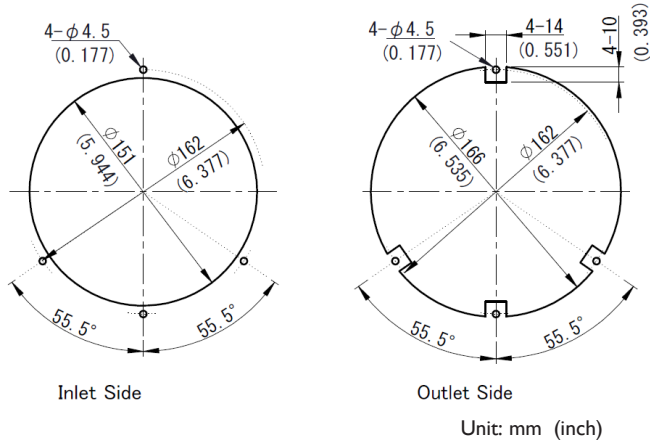

## Materials

- Casing : Aluminum (Paint Black)
- Impeller : Plastic (Black UL94V-0)
- Bearing : Ball Bearing
- Lead Wire : UL10368 AWG22
  - (+) : Red (-) : Black
  - PWM : Brown Tach : White

## Outline

Name Plate

