

Raspberry Pi

Compute Module 4 IO Board

An application board for the
Compute Module 4

Colophon

© 2020 Raspberry Pi (Trading) Ltd.

The documentation around the Raspberry Pi Compute Module 4 is licensed under a Creative Commons [Attribution-NonCommercial-ShareAlike 4.0 International](#) (CC BY-NC-SA).

build-date: 2020-10-05

build-version: githash: ac53e16-clean

Table of Contents

Colophon	1
1. Introduction	3
2. Features	4
2.1. CM4 Module Connectors	4
2.2. PSU input	4
2.3. Dual Full size HDMI 2.0 connectors	4
2.4. Gigabit Ethernet RJ45	5
2.5. USB 2.0 Hub	5
2.6. Micro SDCARD socket	5
2.7. PCIe Gen 2 x1 socket	5
2.8. Fan connector	5
2.9. Dual DSI display connectors (22pin 0.5mm pitch cable)	5
2.10. Dual CSI-2 display connectors (22pin 0.5mm pitch cable)	6
2.11. A Raspberry Pi HAT connector	6
2.12. RTC	6
2.13. Jumpers	6
2.14. LEDs	7
3. Mechanical Diagram	8
4. Circuit Diagram	9

Chapter 1. Introduction

The Raspberry Pi CM4IO board is designed for development of products using the Raspberry Pi Compute Module 4. In some situations the CM4IO board can be used directly in products. The CM4IO board contains many of the interfaces that the Raspberry Pi 4B has, for general usage you should refer to Raspberry Pi 4B documentation. The significant difference to a Raspberry Pi 4B is the addition of the a PCIe x1 socket. The CM4IO board can be used as a reference design for examples of how to interface to the Raspberry Pi Compute Module 4.

Figure 1. Render of the CM4IO board.

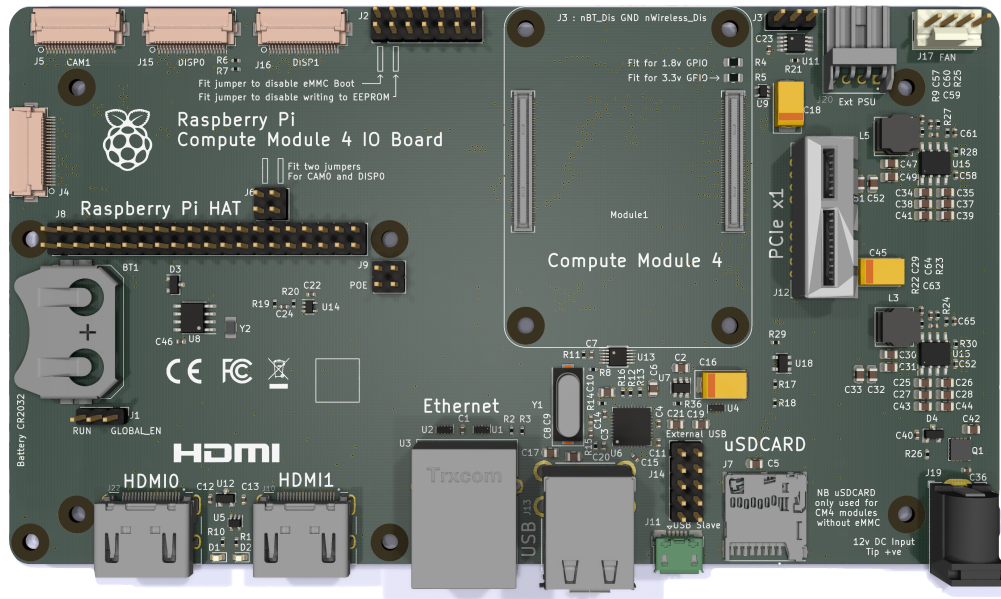

Chapter 2. Features

- Accepts the complete range of CM4 modules
- External +12v PSU
- 2x Full-size HDMI 2.0 connectors
- Gigabit Ethernet RJ45 with POE support
- 2x USB 2 Socket, with header for two more sockets
- Micro USB socket for updating the CM4
- Micro SDCARD socket for CM4Lite modules.
- PCIe Gen 2 x1 socket
- Standard Fan connector
- External power connector (+5, +12v)
- 2x MIPI DSI display FPC connectors (22pin 0.5mm pitch cable)
- 2x MIPI CSI-2 camera FPC connectors (22pin 0.5mm pitch cable)
- Raspberry Pi HAT connector
- RTC with Battery socket and ability to wake up CM4
- Various jumpers to disable features e.g Wireless, EEPROM writing

2.1. CM4 Module Connectors

The two CM4 module connectors are positioned so the onboard wireless antenna is at the edge of the board for best wireless performance.

2.2. PSU input

The main PSU input (J19) is a 2.1mm DC tip positive +12v input. On board there is a +12v to +5v DC-DC converter to power the CM4. There is also an onboard +12v to +3.3v DC-DC converter PSU which is only used for the PCIe slot. The +12v input feeds the +12v PCIe slot, the external PSU connect and the FAN connector directly. If these aren't being used then a wider input supply is possible (+7.5v to +26v).

With a +12v supply via the DC barrel jack the external PSU connector (J20, +5, +12v) is ideal to connect to PCIe cards that require external PSU. You should ensure that the PSUs aren't over loaded. J20 Matting connector is known as "Berg" Part number AMP / TE Connectivity 171822-4 or similar.

The exact current required from the +12v PSU is dependent on the application and what is connected to the CM4IO board. It is recommended to budget 8Watts for the CM4.

2.3. Dual Full size HDMI 2.0 connectors

The CM4 does most of the interfacing required for the HDMI interface so that most signals are directly connected to the CM4. HDMI connectors require a +5v supply, this is provided on the CM4IO board via a current limited switch.

2.4. Gigabit Ethernet RJ45

The CM4IO board uses a standard 1:1 Ethernet magjack, which supports POE as well. Additional ESD protection is provided on the CM4IO board as it is typically needed in POE applications.

2.5. USB 2.0 Hub

The CM4IO board has an onboard USB 2.0 hub. This connects to the CM4 USB 2.0 port. Two ports from the hub are connected to a connector. The two other ports are connected to a header, this header can be used to provide two extra internal ports.

There is an internal current limit switch to provide VBUS to the USB connectors. The current limit is set to approximately 1.2A. Micro USB connector.

The micro USB connector is designed to enable the CM4 to be updated via rpiboot. When a USB cable is plugged in the USB hub is automatically disabled, so the CM4 USB 2.0 port on the CM4 becomes a USB device.

2.6. Micro SDCARD socket

⊖ WARNING

For use only with CM4Lite modules

The SDCARD socket is a PUSH-PUSH socket. To release the SDCARD a gentle push on the SDCARD will enable it to be removed.

2.7. PCIe Gen 2 x1 socket

The PCIe socket is designed to take standard PC PCIe cards. You should ensure that there is a suitable OS driver for your card.

The PCIe link on the Raspberry Pi 4B is used for the USB 3.0 interface via the VLI805 XHCI controller. If the application requires USB 3.0 interface then an external XHCI controller is required like the VLI805.

The PCIe link has been successfully used with an NVMe drive via a passive PCIe adaptor. Currently the CM4 bootloader doesn't support NVMe drives so you must boot via a different source.

If the application uses a standard PCIe card then it might be useful to have a small PCIe adaptor to rotate the PCIe card 90degrees to enable a more compact case.

Note the PCIe Interface doesn't support MSI-X. Typically PCIe devices will fall back to MSI.

2.8. Fan connector

This connector supports standard +12v FANs with PWM drive and tacho output. An EMC2301 controls the fan via I2C. Mating connector part number Molex 47054-1000 or similar. The +12v power for the fan comes from the +12v input and isn't regulated.

2.9. Dual DSI display connectors (22pin 0.5mm pitch cable)

Both DSI interfaces (2 channel and 4 channel) are brought out to separate 22way 0.5mm pitch connectors. These connectors are the same as on the existing CMIO board, NB they are different from the Raspberry Pi 4B. If the DSI0 interface (2 channel) is used then the 2 jumpers on J6 must be fitted to route the I2C bus to the connector

2.10. Dual CSI-2 display connectors (22pin 0.5mm pitch cable)

Both CSI-2 interfaces (2 channel and 4 channel) are brought out to separate 22way 0.5mm pitch connectors. These connectors are the same as on the existing CMIO board, NB they are different from the Raspberry Pi 4B. If the CSIO interface (2 channel) is used then the 2 jumpers on J6 must be fitted to route the I2C bus to the connector

2.11. A Raspberry Pi HAT connector

The CM4IO board has a standard Raspberry Pi 40 way HAT connector. The mounting holes are also provided so that standard HATs may be used.

2.12. RTC

A PCF85063AT RTC is provided on the CM4IO board. A battery socket is provided for a CR2032 battery. On initial setup the CLKOUT of the RTC should be disabled to save power.

The alarm output of the RTC is used to wakeup the CM4 from a previous shutdown. If an alarm goes off during normal operation the CM4 will be reset, this can be used as a watchdog timer if required.

2.13. Jumpers

R4/R5 Vref Voltage Selection

By default the CM4IO board sets the CM4 IO voltage to +3.3v via R5. Moving R5 to R4 sets the IO voltage on the CM4 to +1.8v . Moving the resistor requires the use of the soldering iron. NB Only of R4 R5 must be fitted at any one time.

i NOTE

J6 CSIO DSIO I2C enable

For the J6 jumpers, if either CSIO or DSIO it used then both jumpers must be fitted to route the I2C bus to the connectors

Table 1. J2 jumpers

Pin	Function
1-2	nRPIBOOT If fitted forces USB booting, it is useful if the eMMC becomes corrupted.
3-4	EEPROM_nWP If fitted write protects the EEPROM on the CM4
5	AIN1 MXL7704 analog input consult MXL7704 datasheet for details
6	AIN0 MXL7704 analog input consult MXL7704 datasheet for details
7	GND for AIN signals
8	SYNC_IN
9	SYNC_OUT
10	GND
11	TV_OUT
12	GND
13-14	Connect a push button to wake up the CM4 from low power mode. It can't be used to shutdown the CM4.

Table 2. J3 (not fitted by default)

Pin	Function
1	WL_nDIS when connected to ground the wireless interface will be disabled

2	GND Ground
3	BT_nDIS when connected to ground the Bluetooth interface will be disabled

Table 3. J1 (not fitted by default)

Pin	Function
1	GLOBAL_EN
2	GND
3	RUN_PG

2.14. LEDs

Red LED

This LED duplicates the function of the RED LED on the Raspberry Pi 4B

Green LED

This LED duplicates the function of the GREEN LED on the Raspberry Pi 4B

Chapter 3. Mechanical Diagram

Figure 2. Mechanical diagram of the CM4IO board.

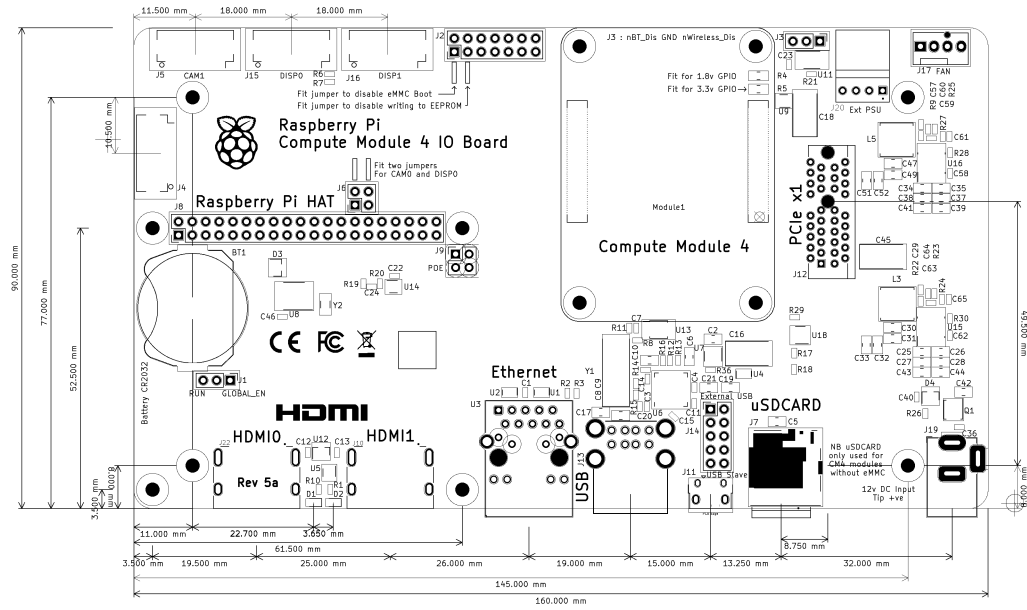

Chapter 4. Circuit Diagram

Figure 3. Top level

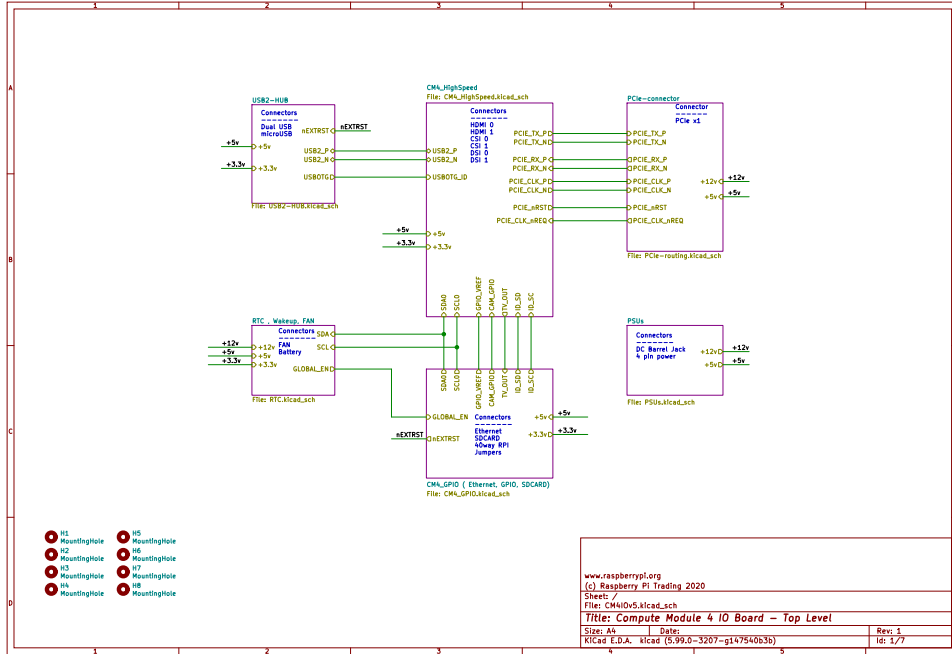

Figure 4. CM4 Highspeed

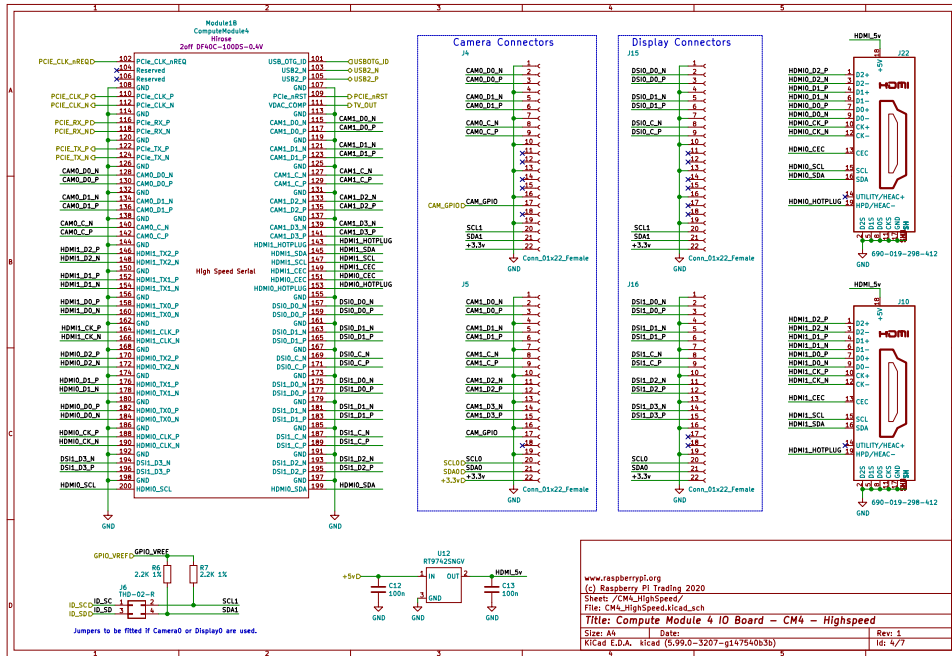

Figure 5. CM4 GPIO

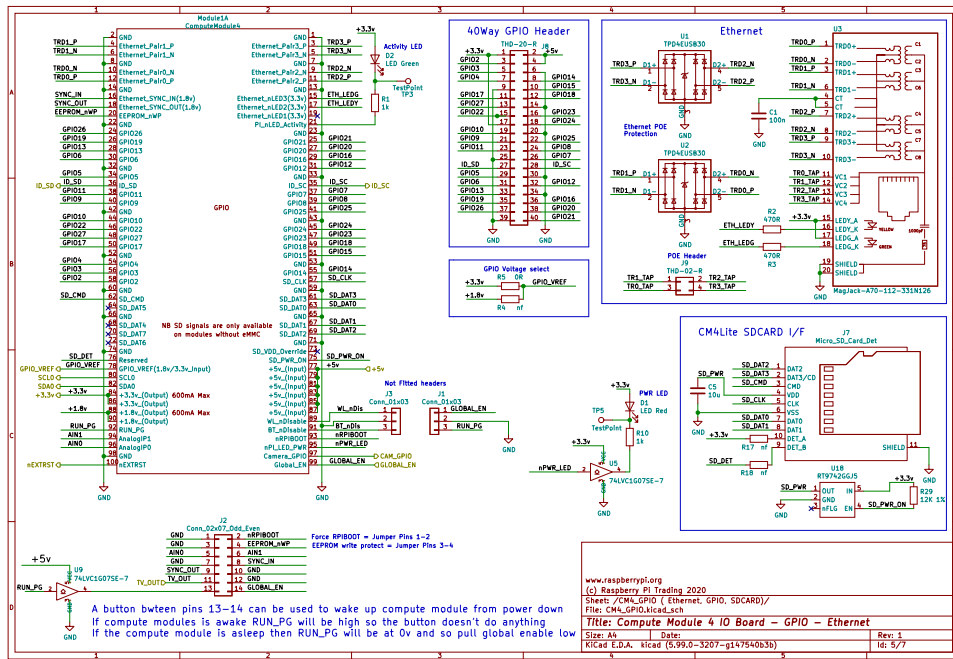

Figure 6. PCIe Connector

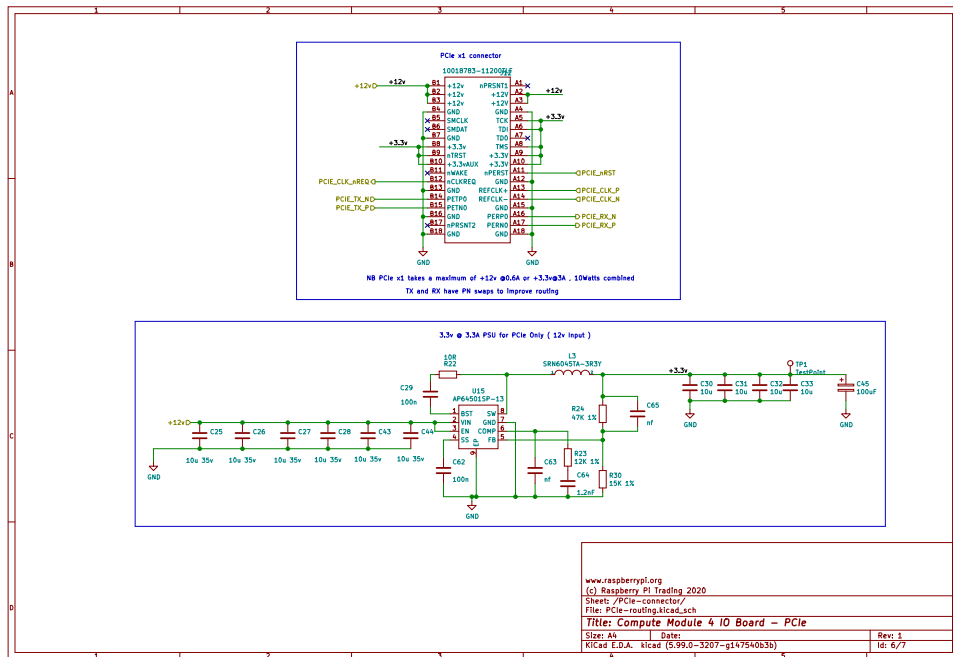

Figure 7. USB2 Hub

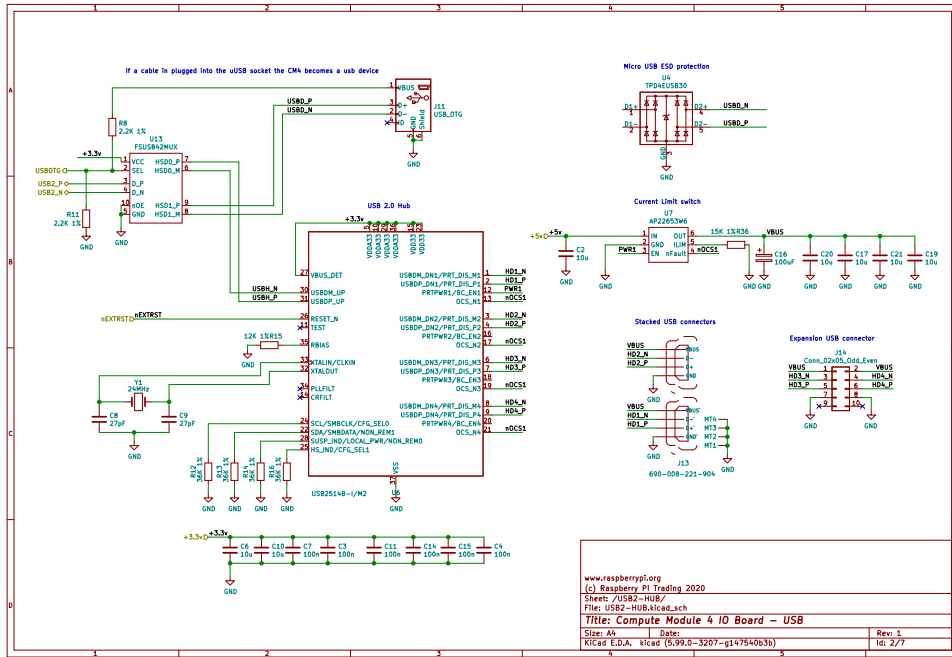

Figure 8. RTC Wakeup FAN

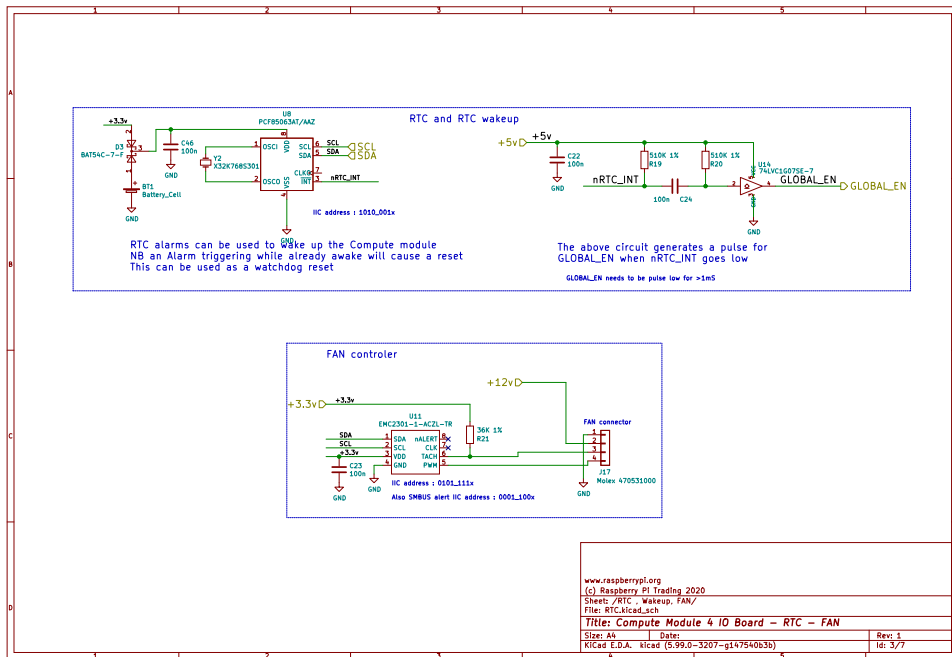
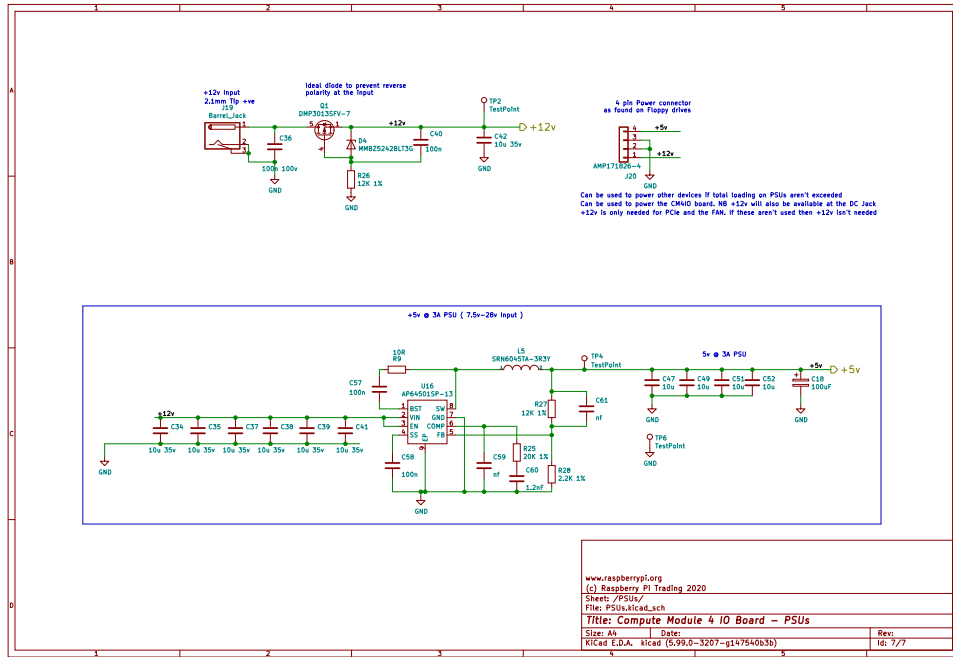

Figure 9. PSU





Raspberry Pi

Raspberry Pi is a trademark of the Raspberry Pi Foundation

Raspberry Pi Trading Ltd