

EA-PS 9000 2U 1000 W - 3000 W



Programmable laboratory DC Power supplies



EA-PS 9500-20 2U



- Wide input voltage range: 90...264 V, with active PFC
- High efficiency: up to 93%
- Output power ratings: 0..1000 W up to 0...3000 W
- Output voltages: 0...40 V up to 0...750 V
- Output currents: 0...4 A up to 0...120 A
- Flexible, power regulated output stage
- Various protection circuits (OVP, OCP, OPP, OTP)
- Control panel with pushbuttons and color TFT for actual values, set values, status and alarms
- Galvanically-isolated analog interface and USB port
- 40 V models according to SELV (EN 60950)
- Discharge circuit ($U_{out} < 60 \text{ V}$ in $\leq 10 \text{ s}$)
- Ethernet port integrated, alternatively GPIB
- EMC according to EN 55022 Class B
- SCPI command set and ModBus RTU support

General

The microprocessor-controlled laboratory power supplies of series EA-PS 9000 2U offer many functions and features in their standard version, making the use of this equipment remarkably easy and most effective.

The clearly arranged control panel features two rotary knobs, six pushbuttons and two LEDs. Together with a color TFT display for all values and status it simplifies the use of the device.

AC supply

All units are provided with an active Power Factor Correction circuit and models up to 1.5 kW are even suitable for a worldwide operation on a supply from 90 V_{AC} up to 264 V_{AC}. With the 1.5 kW models, the output power is automatically reduced to 1 kW if the supply voltage is <150 V_{AC} and with the 3 kW models is reduced to 2.5 kW at <205 V_{AC}.

Power

All models are equipped with a flexible auto-ranging output stage which provides a higher output voltage at lower output current, or a higher output current at lower output voltage, always limited to the max. nominal output power. The power set value is adjustable with these models. Therefore, a wide range of applications can already be covered by the use of just one unit.

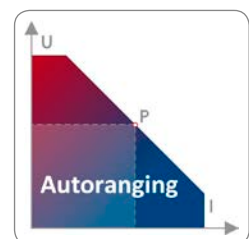

EA-PS 9000 2U 1000 W - 3000 W

DC output

DC output voltages between 0...40 V and 0...750 V, output currents between 0...4 A and 0...120 A and output power ratings between 0...1000 W and 0...3000 W are available.

Current, voltage and power can thus be adjusted continuously between 0% and 100%, no matter if manually or remotely controlled (analog or digital). The DC output is located on the rear panel of the devices.

Discharge circuit

Models with a nominal output voltage of 200 V or higher include a discharge circuit for the output capacities. For no load or low load situations, it ensures that the dangerous output voltage can sink to under 60 V DC after the DC output has been switched off. This value is considered as limit for voltages dangerous to human safety.

Protective features

For protection of the equipment connected, it is possible to set an overvoltage protection threshold (OVP), as well as one for overcurrent (OCP) and overpower (OPP).

As soon as one of these thresholds is reached for any reason, the DC output will be immediately shut off and a status signal will be generated on the display and via the interfaces. There is furthermore an overtemperature protection, which will shut off the DC output if the device overheats.

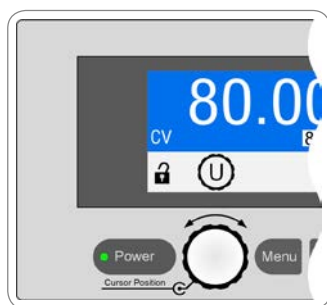

Display and controls

All important information is clearly visualised on a color TFT display.

With this, information about the actual output values and set values of voltage and current, the actual control state (CV, CC, CP) and other statuses, as well as alarms and settings of the setup menu are clearly displayed.

In order to ease adjusting of values by the rotary knobs, pushing them can switch between decimal positions of a value. All these features contribute to an operator friendliness.

With a panel lock feature, the whole panel can be locked in order to protect the equipment and the loads from unintentional misuse.

Analog interface

There is a galvanically isolated analog interface terminal, located on the rear of the device. It offers analog inputs to set voltage, current and power from 0...100% through control voltages of 0 V...10 V or 0 V...5 V.

To monitor the output voltage and current, there are analog outputs with voltage ranges of 0 V...10 V or 0 V...5 V. Also, several inputs and outputs are available for controlling and monitoring the device status.

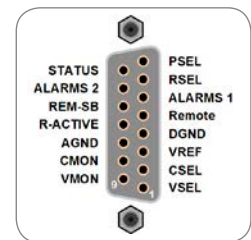

Digital interfaces

All models features two galvanically isolated, digital interfaces by default (standard: 1x USB & 1x Ethernet, with option 3W: 1x USB & 1x GPIB), which are located on the rear side. USB and Ethernet can be used to control and monitor the devices either with SCPI language commands or ModBus RTU protocol, while with GPIB only SCPI is supported.

Software and programming

For remote control from a Windows PC there is a software EA Power Control (see page 110) included with the device. It can be used with multiple different or identical models of series EA-PS 9000 2U to monitor and control the units. The software furthermore includes a firmware update tool, as well as a feature to record data and to control the units by a semi-automatic table processing.

For even more sophisticated, customer specific applications there is a complete programming documentation and also LabView VIs for direct implementation available.

All models of series EA-PS 9000 2U support the common command language **SCPI** and the **ModBus RTU** protocol via Ethernet and USB. Models with option 3W can only use SCPI via the GPIB port.

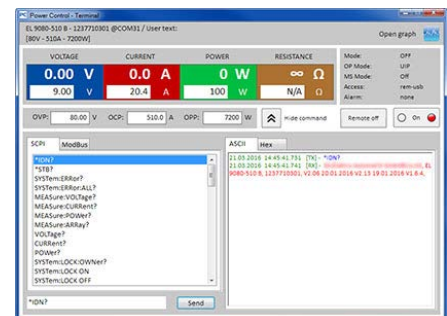

Remote sensing

Remote sensing can be done via a dedicated input which is directly connected to the load equipment, in order to compensate voltage drops along the load cables. The power supply detects automatically whether the sensing input is connected and will stabilise the voltage directly at the load. The connection for the remote sensing is located on the rear of the device.

Options

- Three-way interface (3W) with a rigid GPIB port installed instead of the default Ethernet port



EA-PS 9000 2U 1000 W - 3000 W

Product views

- A
- B
- C
- D
- E

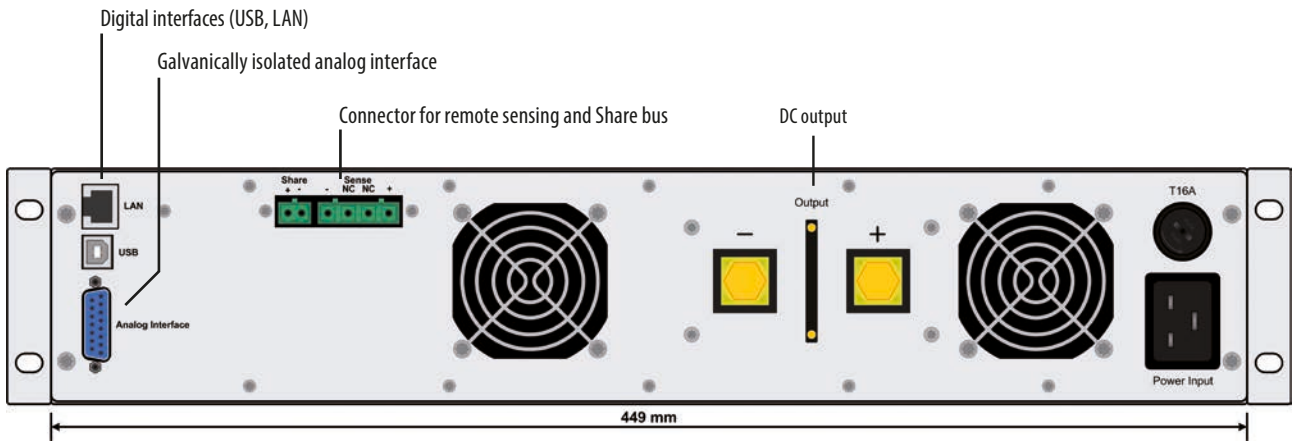

Rear view of base model

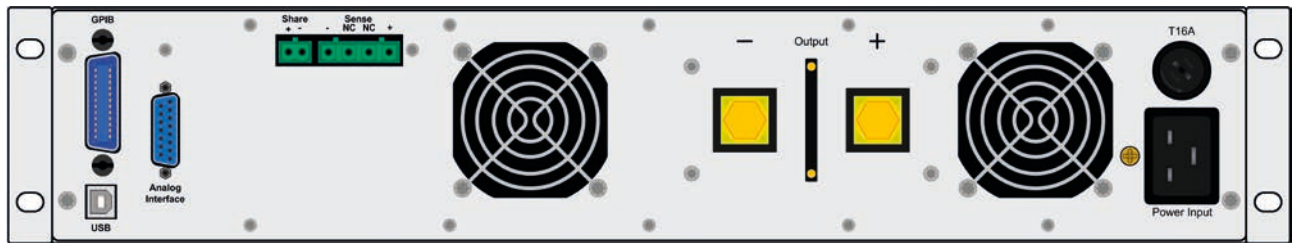

Rear view of model with option 3W

Model	Voltage	Current	Power	Efficiency	Ripple U max.	Ripple I max.	Programming ⁽¹⁾		Ordering number ⁽³⁾
							U (typ.)	I (typ.)	
PS 9040-40 2U	0...40 V	0...40 A	0...1000 W	≤92%	114 mV _{pp} / 8 mV _{RMS}	3.7 mA _{RMS}	≈1.5 mV	≈1.5 mA	06230219
PS 9080-40 2U	0...80 V	0...40 A	0...1000 W	≤92%	114 mV _{pp} / 8 mV _{RMS}	3.7 mA _{RMS}	≈3 mV	≈1.5 mA	06230204
PS 9200-15 2U	0...200 V	0...15 A	0...1000 W	≤93%	164 mV _{pp} / 34 mV _{RMS}	2.2 mA _{RMS}	≈7.6 mV	≈0.6 mA	06230205
PS 9360-10 2U	0...360 V	0...10 A	0...1000 W	≤93%	210 mV _{pp} / 59 mV _{RMS}	1.6 mA _{RMS}	≈13.7 mV	≈0.4 mA	06230206
PS 9500-06 2U	0...500 V	0...6 A	0...1000 W	≤93%	190 mV _{pp} / 48 mV _{RMS}	0.5 mA _{RMS}	≈19 mV	≈0.23 mA	06230207
PS 9750-04 2U	0...750 V	0...4 A	0...1000 W	≤93%	212 mV _{pp} / 60 mV _{RMS}	0.3 mA _{RMS}	≈28.6 mV	≈0.15 mA	06230208
PS 9040-60 2U	0...40 V	0...60 A	0...1500 W	≤92%	114 mV _{pp} / 8 mV _{RMS}	5.6 mA _{RMS}	≈1.5 mV	≈2.3 mA	06230220
PS 9080-60 2U	0...80 V	0...60 A	0...1500 W	≤92%	114 mV _{pp} / 8 mV _{RMS}	5.6 mA _{RMS}	≈3 mV	≈2.3 mA	06230209
PS 9200-25 2U	0...200 V	0...25 A	0...1500 W	≤93%	164 mV _{pp} / 34 mV _{RMS}	3.3 mA _{RMS}	≈7.6 mV	≈1 mA	06230210
PS 9360-15 2U	0...360 V	0...15 A	0...1500 W	≤93%	210 mV _{pp} / 59 mV _{RMS}	2.4 mA _{RMS}	≈13.7 mV	≈0.6 mA	06230211
PS 9500-10 2U	0...500 V	0...10 A	0...1500 W	≤93%	190 mV _{pp} / 48 mV _{RMS}	0.7 mA _{RMS}	≈19 mV	≈0.4 mA	06230212
PS 9750-06 2U	0...750 V	0...6 A	0...1500 W	≤93%	212 mV _{pp} / 60 mV _{RMS}	0.5 mA _{RMS}	≈28.6 mV	≈0.23 mA	06230213
PS 9040-120 2U	0...40 V	0...120 A	0...3000 W	≤92%	114 mV _{pp} / 8 mV _{RMS}	11 mA _{RMS}	≈3 mV	≈4.6 mA	06230221
PS 9080-120 2U	0...80 V	0...120 A	0...3000 W	≤92%	114 mV _{pp} / 8 mV _{RMS}	11 mA _{RMS}	≈1.5 mV	≈4.6 mA	06230214
PS 9200-50 2U	0...200 V	0...50 A	0...3000 W	≤93%	164 mV _{pp} / 34 mV _{RMS}	6.5 mA _{RMS}	≈7.6 mV	≈1.9 mA	06230215
PS 9360-30 2U	0...360 V	0...30 A	0...3000 W	≤93%	210 mV _{pp} / 59 mV _{RMS}	5 mA _{RMS}	≈13.7 mV	≈1.2 mA	06230216
PS 9500-20 2U	0...500 V	0...20 A	0...3000 W	≤93%	190 mV _{pp} / 48 mV _{RMS}	1.5 mA _{RMS}	≈19 mV	≈0.8 mA	06230217
PS 9750-12 2U	0...750 V	0...12 A	0...3000 W	≤93%	212 mV _{pp} / 60 mV _{RMS}	0.9 mA _{RMS}	≈28.6 mV	≈0.5 mA	06230218

(1) Programmable resolution disregarding device errors
 (2) RMS value: measures at LF with BWL 300 kHz, PP value: measured at HF with BWL 20MHz
 (3) Ordering number of the standard version, models with option 3W installed have different ordering numbers

EA-PS 9000 2U 1000 W - 3000 W

Technical Data	Series PS 9000 2U	
AC: Supply		
- Voltage	90...264 V, 1ph+N or 2ph (1000 W - 1500 W models) 180...264 V, 1ph+N or 2ph (3000 W models)	
- Frequency	45...66 Hz	
- Power factor	>0.99	
- Derating	1500 W models: < 150 V AC to P _{out max} 1000 W 3000 W models: < 207 V AC to P _{out max} 2500 W	
DC: Voltage		
- Accuracy	<0.1% of rated value	
- Load regulation 0-100%	<0.05% of rated value	
- Line regulation ±10% ΔU _{ac}	<0.02% of rated value	
- Regulation 10-100% load	<2 ms	
- Rise time 10-90%	Max. 30 ms	
- Overvoltage protection	Adjustable, 0...110% U _{Nom}	
DC: Current		
- Accuracy	<0.2% of rated value	
- Load regulation 1-100% ΔU _{dc}	<0.15% of rated value	
- Line regulation ±10% ΔU _{ac}	<0.05% of rated value	
DC: Power		
- Accuracy	<1% of rated value	
Overvoltage category	2	
Protection	OTP, OVP, OCP, OPP, PF ⁽¹⁾	
Insulation		
- AC input to enclosure	2500 V DC	
- AC input to output	2500 V DC	
- DC output to enclosure (PE)	Negative: max. 400 V DC, positive: max. 400 V DC + output voltage	
Degree of pollution	2	
Protection class	1	
Display and panel	Color display, knobs and pushbuttons	
Digital interfaces		
- Built-in	1x USB type B for communication, 1x Ethernet Optional: 1x GPIB (with option 3W)	
Analog interface	Built in, 15 pole D-Sub (female), galvanically isolated	
- Signal range	0...5 V or 0...10 V (switchable)	
- Inputs	U, I, P, remote control on-off, DC output on-off	
- Outputs	U, I, overvoltage, alarms, reference voltage	
- Accuracy U / I / P	0...10 V: <0.2%	0...5 V: <0.4%
Parallel operation	Possible, via Share Bus operation or via analog interface	
- Master-Slave	No	
Standards	EN 60950, EN 61326, EN 55022 Class B	
Cooling	Temperature-controlled fan(s)	
Operation temperature	0...50 °C	
Storage temperature	-20...70 °C	
Humidity	<80%, non-condensing	
Operation altitude	<2000 m (1.242 mi)	
Mechanics	1000 W / 1500 W	3000 W
- Weight ⁽²⁾	12 kg (26.4 lb)	15 kg (33.1 lb)
- Dimensions (W x H x D) ⁽³⁾	19" x 2U x 463 mm (18.2")	19" x 2U x 463 mm (18.2")

⁽¹⁾ See page 118

⁽²⁾ Standard version, models with options may vary

⁽³⁾ Enclosure of the standard version and not overall size, versions with options may vary

