

Automotive-grade Dual DC motor driver up to 15A each

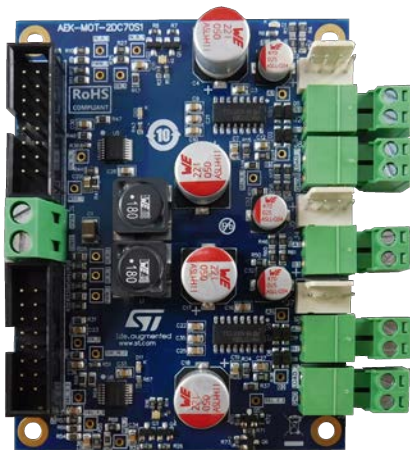

Features

- Dual DC motor driver
 - Parallel driving
 - Bi-directional
 - Output current up to 15A each device
- Three DC motor drivers
 - Up to two in parallel
 - Bi-directional
- Dual high-side driver
 - Parallel driving
 - Suitable for DC unidirectional driving
 - One channel up to 85 A and the other up to 25 A
- Optional encoder input
 - Three separated connectors
- Size 65 mm x 83 mm
- Included in AutoDevKit initiative
- RoHS compliant



Description

The **AEK-MOT-2DC70S1** is a very compact solution for multi DC motor driving applications, embedding all the driver and signal decoding functions on the same board.

Together with current sensing capability, the AEK-MOT-2DC70S1 features three independent encoder inputs. The DC motor drivers have separate half-bridge driving which allows up to three separate motors with only two devices, using an appropriate driving sequence.

The motor driver is ideal for two-wheel applications and allows engineers to build highly compact motor control solutions. The two high-side drivers facilitate additional driving for system actuators (unidirectional DC motor, LED, pump, etc.).

Product summary	
Automotive-grade Dual DC motor driver up to 15A each	AEK-MOT-2DC70S1
High-side driver with MultiSense analog feedback for automotive applications	VN7050AJ
High-side driver with MultiSense analog feedback for automotive applications	VN7E010AJ
Automotive fully integrated H-bridge motor driver	VN7070BAS
AutoDevKit library plugin for SPC5-STUDIO	STSW-AUTODEVKIT
AutoDevKit library plugin for SPC5-STUDIO	SPC5-STUDIO

1 Block diagram

Figure 1. AEK-MOT-2DC70S1 block diagram

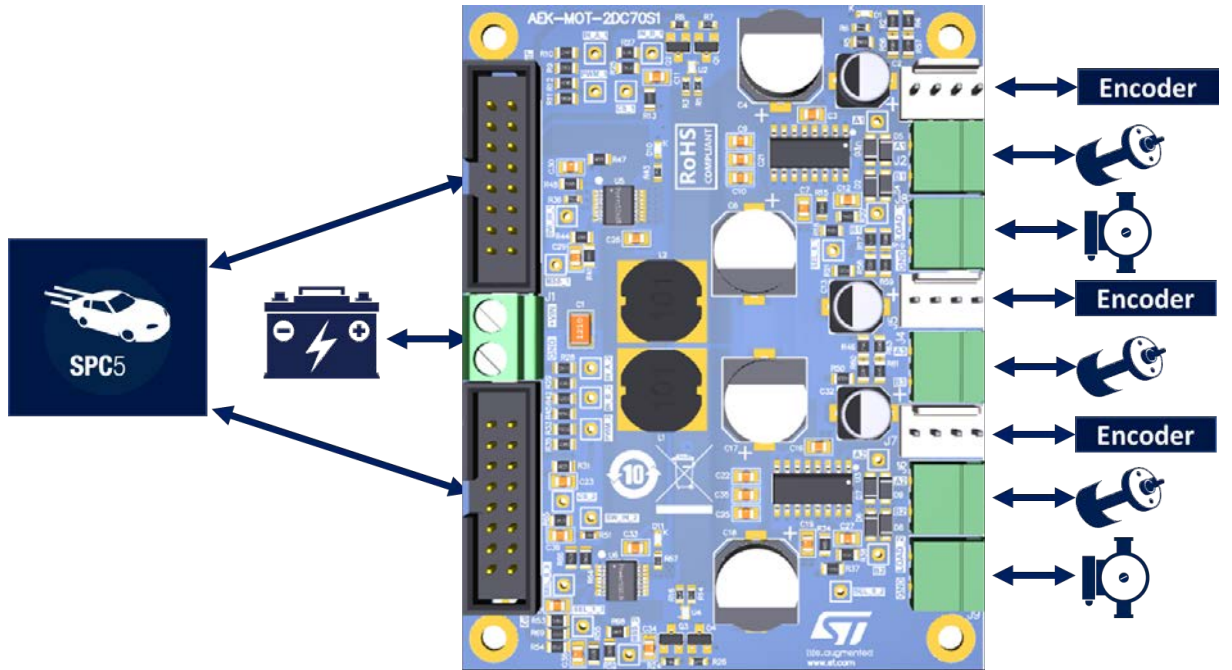

2 Schematic diagrams

Figure 2. AEK-MOT-2DC70S1 board schematic

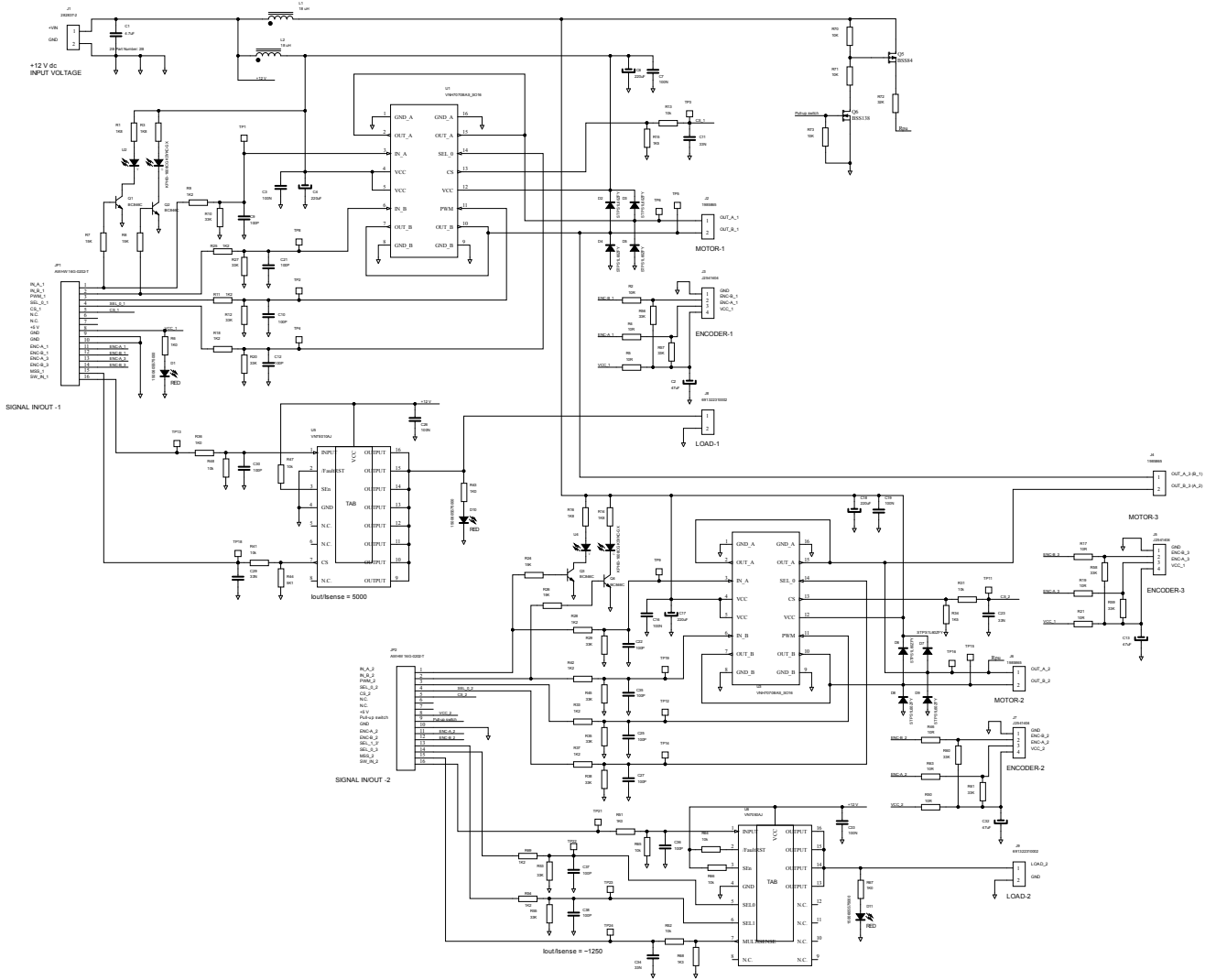

3 Key IC device features

Table 1. Key IC device features

Product	Features	Max transient supply voltage	Operating voltage range		Typ on-state resistance per CH $R_{DS(on)}$ (m Ω)	Current limitation (I _{lim}) typ (A)	Stand-by current (max) I _{stby} (μ A)
			Min (V)	Max (V)			
VNH7070BAS	H-bridge motor driver	40 V	4	28	70	15	1
VN7E010AJ	High-side driver	40 V	4	28	10.5	88	0.5
VN7050AJ	High-side driver	40 V	4	28	50	30	0.5

4 Connector pin-out

Table 2. Connector pin-out

Pin name	Pin number	Connector	Pin function
IN_A_1, IN_A_2	1	JP1, JP2	Clockwise input for H-bridge motor driver
IN_B_1, IN_B_2	2	JP1, JP2	Counter-clockwise input for H-bridge motor driver
PWM_1, PWM_2	3	JP1, JP2	A square wave signal up to 20 kHz can be used on this pin for motor speed control (H-bridge motor driver)
SEL_0_1, SEL_0_2	4	JP1, JP2	In combination with INA and INB, it addresses the CurrentSense information delivered to the micro according to the truth table (H-bridge motor driver)
CS_1, CS_2	5	JP1, JP2	Multiplexed analog sense output pin for H-bridge motor driver. It delivers a current proportional to the HSA output current if SEL0 is set high; and to the HSB if SEL0 is set low. It develops a voltage flag for a failure on the relevant output in the ON-state as well as the OFF-state
N.C.	6,7	JP1, JP2	Not connected
+5V	8	JP1, JP2	5V voltage supply Voltage for Encoder
GND	9	JP1	Ground
Pull-up switch	9	JP2	Enable pull-up resistor for open load detection in OFF-state for H-bridge motor driver
GND	10	JP1, JP2	Ground
ENC-A_1, ENC-B_1	11,12	JP1	Encoder output 1
ENC-A_2, ENC-B_2	11,12	JP2	Encoder output 2
ENC-A_3, ENC-B_3	13,14	JP1	Encoder output 3
SEL_1_3, SEL_0_3	13,14	JP2	Address the MultiSense multiplexer for VN7050AJ High side driver
MSS_1, MSS_2	15	JP1, JP2	Analog current sense output pin; it delivers a current proportional to the selected load current for High side driver
SW_IN_1, SW_IN_2	16	JP1, JP2	Controls output switch state for High side driver

5 AEK-MOT-2DC70S1 dedicated software component

Through the dedicated AutoDevKit component, motors can be selectively activated according to application requirements. The dedicated GUI allows intuitive management of three motors directly connected to the VNHxxx devices (MOTOR 1, MOTOR 3, MOTOR 5). For each motor, it is possible to set rotation direction and to connect an encoder for precise positioning. MOTOR / LOAD 2 and MOTOR / LOAD 4 are connected on the VNxxx devices and are therefore they are unidirectionally driven. MOTOR 1, MOTOR / LOAD 2, MOTOR 3, MOTOR / LOAD 4 can be driven in parallel, while MOTOR 5 should be activated separately to avoid improper driving on MOTOR 1 and MOTOR 3.

AutoDevKit high-level drivers are very straightforward and comprehensive API support is available through online help in SPC5Studio. The user can invoke the desired functions such as starting a DC motor, increasing or decreasing the DC rotation speed, and braking by just passing the motor parameter (e.g., MOTOR 1, MOTOR 2, ... MOTOR 5) to them.

The API set includes diagnostic functions indicating if the device is in *Fault* or in *Operative* mode. Moreover, it is possible to monitor the device even when it is switched off, to avoid starting the application the application while faults are present.

Inside AutoDevKit plugin, there are several examples of API usage, including one using an encoder. The encoder has a 'K' factor that should be set in the appropriate #DEFINE in the encoder driver according to the specific motor model.

The AutoDevKit also allows you to implement custom PID control, useful for negative feedback systems, by modifying the relevant #DEFINE statements in the PID driver code.

Revision history

Table 3. Document revision history

Date	Version	Changes
14-Oct-2020	1	Initial release.

IMPORTANT NOTICE – PLEASE READ CAREFULLY

STMicroelectronics NV and its subsidiaries (“ST”) reserve the right to make changes, corrections, enhancements, modifications, and improvements to ST products and/or to this document at any time without notice. Purchasers should obtain the latest relevant information on ST products before placing orders. ST products are sold pursuant to ST’s terms and conditions of sale in place at the time of order acknowledgement.

Purchasers are solely responsible for the choice, selection, and use of ST products and ST assumes no liability for application assistance or the design of Purchasers’ products.

No license, express or implied, to any intellectual property right is granted by ST herein.

Resale of ST products with provisions different from the information set forth herein shall void any warranty granted by ST for such product.

ST and the ST logo are trademarks of ST. For additional information about ST trademarks, please refer to www.st.com/trademarks. All other product or service names are the property of their respective owners.

Information in this document supersedes and replaces information previously supplied in any prior versions of this document.

© 2020 STMicroelectronics – All rights reserved