

VM25B

Vehicle Megaphone 25W

Item ref: 952.007UK

User Manual

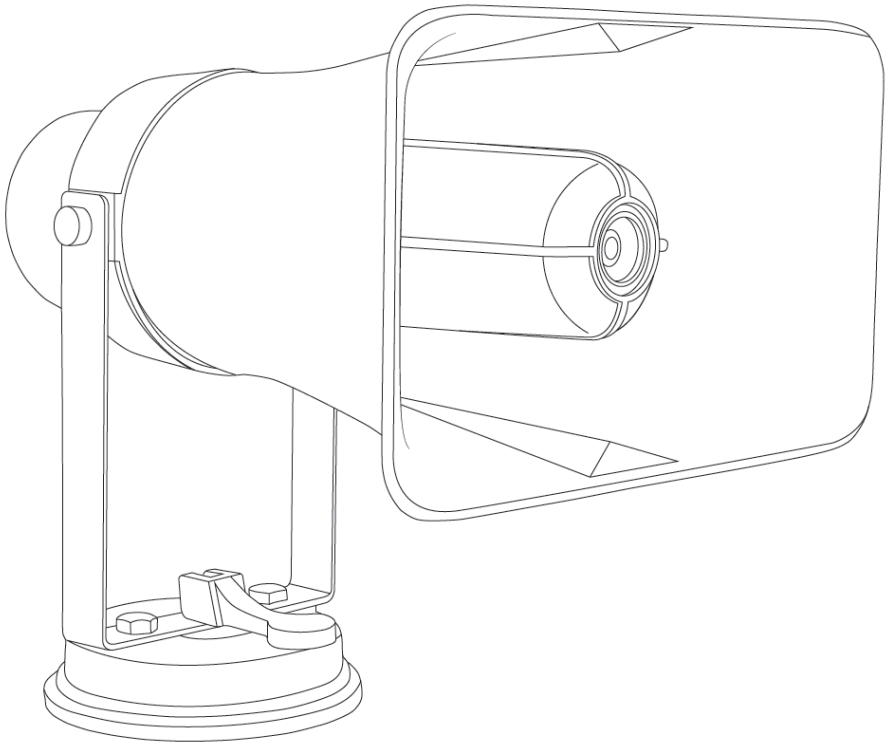



Caution: Please read this manual carefully before operating
Damage caused by misuse is not covered by the warranty

Introduction

Thank you for choosing the Adastra VM25B car roof megaphone for mobile announcements. This product is designed to offer convenient and easy operation for a wide range of portable public address requirements. Please use the following instructions to gain the best results from your megaphone.

Safety

The VM25B can produce high sound pressure levels at close quarters. Please be aware not to aim the horn flare toward listeners at close proximity, which may risk damage to the listeners' hearing.

The VM25B is powered from the vehicle's 12Vdc supply. There are no re-chargeable batteries inside.

Positioning during operation

The mounting bracket is provided with a suction cup for mounting to a suitable area of the vehicle roof. Ensure that the surface is clean to avoid damage to the finish.

Cleaning

The horn housing is water resistant and can be cleaned with a damp cloth. Do not use detergents or solvents on the housing and take care not to allow liquids to get inside the housing at the rear. Keep the handset inside the vehicle and away from moisture.

Handset Controls

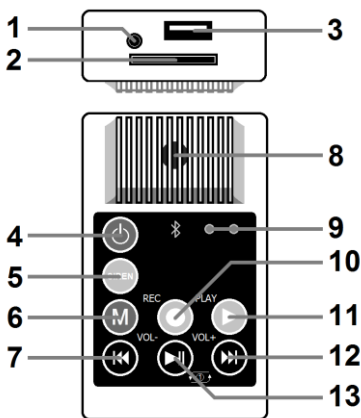

1. 3.5mm AUX input
2. SD card slot
3. USB input
4. Power on/off
5. Siren
6. Mode select
7. Previous track / Vol -
8. Microphone
9. LED indicators
10. Loop record
11. Loop playback
12. Next track / Vol +
13. Play / Pause media

Setting up

The VM25B megaphone is fitted with a lever-action suction cup for fitting to a vehicle roof. Before using this, ensure that the mounting surface is clean and clear of debris to avoid damages to the finish and ensure an air-tight seal. Moisten the rubber foot of the suction cup and place the VM25B into position with the suction lever in the 'up' position, press down firmly and pull the lever down to the horizontal position. Check that the seal is strong and that the VM25B cannot be moved. Alternatively, for permanent installation, the suction cup can be removed and the mounting bracket can be bolted in place.

The VM25B is pre-wired with a fixed microphone lead which has a DIN connector at the end. The comms handset connects to this lead via a corresponding DIN plug. Feed the lead from the VM25B into the vehicle cabin through a window or bulkhead and connect the handset, ensuring that the DIN connectors are orientated correctly (each connector has a matching key to ensure correct connection).

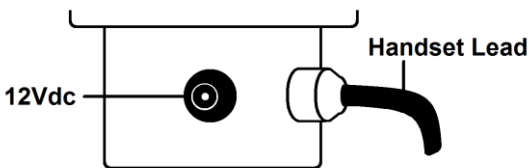

For power, the VM25B has a 12Vdc input near to the hard-wired microphone lead. A DC lead is provided for powering from a vehicle 12V outlet and this should also be fed into the vehicle cabin through a window or bulkhead and connected to the 12V outlet.

Operation

Once power is connected, press the Power on/off button (4) to activate the VM25B and a red LED light on the upper right-hand side of the number pad to show that it is powered on (9). and speak into the microphone (8). To adjust the volume, press and hold the Vol- or Vol+ buttons (7, 12)

To create a looped message, press the Loop Record button (10) and the LED indicator (9) will light red. Speak into the microphone and press the Loop Record button again to stop recording.

The loop can be up to 120 seconds in length. To play back the loop, press the Loop Playback button (11) and the recorded speech will play back continuously. Press the Loop Playback button again to stop the loop. Again, Vol- and Vol+ can adjust the volume of the playback. To record a new loop, press the Loop Record button again to over-write message and erase the previous loop.

The top of the handset of the VM25B is fitted with a USB input (3) and SD card slot (2) for connecting memory devices. Connect a USB memory stick and/or SD card with digital audio files stored on them here and playback will begin automatically. Track navigation is controlled by the Previous, Next and Play/Pause buttons (7, 12, 13). Short press the Previous or Next buttons to skip through tracks or long press these buttons to adjust volume (Vol- or Vol+). Play/Pause can pause the current track and restart it. The button marked 'M' is the Mode selector (6) and selects between USB or SD media, Aux or Bluetooth mode.

Connecting a line input to the stereo 3.5mm aux jack input (1), such as an mp3 player or smart phone will allow playback from that source. To switch from this to USB or SD card playback, press the Mode button.

The VM25B also has a built-in Bluetooth receiver, which allows wireless playback of tracks stored on a smart phone. Another application for this is to use one of the many Bluetooth microphone apps available, enabling the smart phone to become a wireless microphone for the VM25B. If using the Bluetooth in this way, care must be taken to keep the smart phone from “hearing” its own output and causing feedback.

When Bluetooth is active, the LED indicator (9) will flash green. Open the Bluetooth menu on the smart phone and search for a device called “Megaphone bluetooth”, then select to pair with it. When pairing is confirmed, there will be a confirmation sound played through the horn, the LED will stop flashing and any playback from the smart phone will be sent to the VM25B. If there is no playback through the horn, check volume of the smart phone and the Vol+ button on the handset to ensure that the volume is not turned down. Otherwise, check that there are no other paired “Megaphone bluetooth” devices stored. If so, check through each in turn to find the correct unit. Bluetooth range is typically 5-8m and if out of range, there will be no playback and it is necessary to re-connect with the VM25B for playback to be resumed.

Playback controls ▶, ⏪ and ⏩ operate in a similar way for Bluetooth as for USB/microSD playback.

The VM25B also has a Siren button (5) for alert sounds. Press this for emergency alerts.

Warning: the siren is loud for attracting attention. Take care not to direct to listeners at close range.

Press the Power on/off button to power down when not in use.

Specifications

Power supply	12Vdc (DC5521 connector)
Power: max.	25W
IP rating	IP66
Audio source	Microphone, looper, USB/SD/Aux/Bluetooth player
Range	700m - 1km
Lead length	12Vdc Power lead 5m, Handset lead 4m
Dimensions	295 x 265 x 255mm
Weight	2.14kg

Troubleshooting

No output when Push-to-Talk is pressed	Press the Power on/off button and ensure the red LED is lit
	Press and hold Vol+ during Press-to-Talk to ensure volume is not muted
	Ensure that the power input is receiving 12Vdc from vehicle or PSU
No Bluetooth playback	Check volume controls on handset and smart phone
	Ensure that the “Megaphone bluetooth” device is paired successfully
No playback of digital audio files	Ensure that the media is .mp3 or .wma format
	Ensure memory device is inserted correctly
	Press and hold Vol+ during playback to ensure volume is not muted
	Press the ‘M’ button (mode) to ensure the correct source is selected
Loud squeal or feedback	Press and hold Vol- during Press-to-Talk to reduce the output level
Speech is too quiet	Press and hold Vol+ during Press-to-Talk to increase the output level



Disposal: The “Crossed Wheelie Bin” symbol on the product means that the product is classed as Electrical or Electronic equipment and should not be disposed with other household or commercial waste at the end of its useful life. The goods must be disposed of according to your local council guidelines.

*Errors and omissions excepted.
Copyright© 2020. AVSL Group Ltd.*