

CONNECT AND PROTECT

Front Panel Component Systems

nvent

SCHROFF

Front panel component system

OVERVIEW

MAIN KATALOG

- Cabinets 1
- Wall mounted cases 2
- Accessories for cabinets and wall mounted cases .. 3
- Climate control .. 4
- Electronics cases 5
- Subracks/ 19" chassis 6
- Front panels, plug-in units 7
- Systems 8
- Power supply units 9
- Backplanes 10
- Connectors, front panel component system 11
- Appendix 12

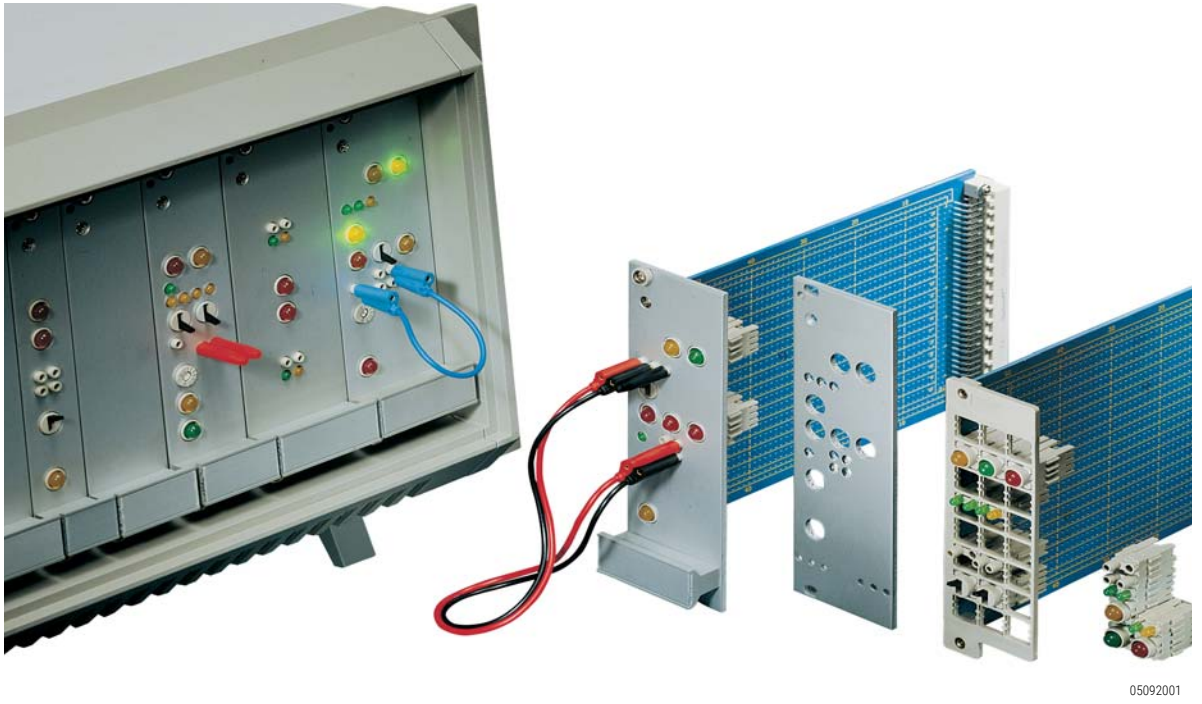

Components are pre-mounted in plastic bodies that can be arranged in rows; horizontal grid (3 planes) and vertical grid (8 or 16 planes)

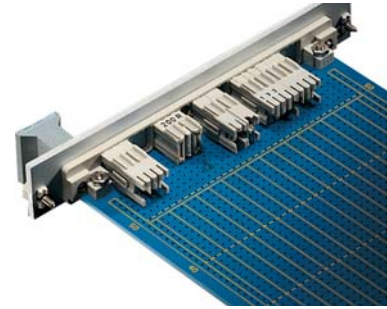

Front element system in use

STANDARDS

- IEC 60297-3-101
- IEC 60603 (DIN 41494 part 8)

Front panel component system

OVERVIEW

OPERATING AND DISPLAY ELEMENTS FOR FRONT PANELS

- Pre-assembled front element components
- Mounting frames with integrated PCB brackets
- Assembled front elements can be soldered in one step
- Subsequent front panel mounting

Overview 11.12

Front panel component system

Single LEDs 11.14

Double LEDs 11.16

Technical data LEDs 11.17

Test sockets 11.18

Make-break socket. 11.19

Technical data for test and make-break sockets and fuse holders 11.20

Potentiometers 11.21

Design aids 11.22



LEDs (light-emitting diodes)

05092009

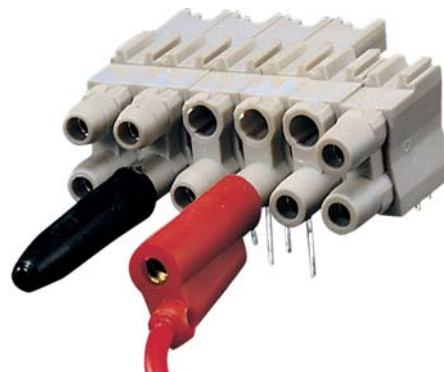

Test and make-break sockets

05092005



Potentiometers

05092007

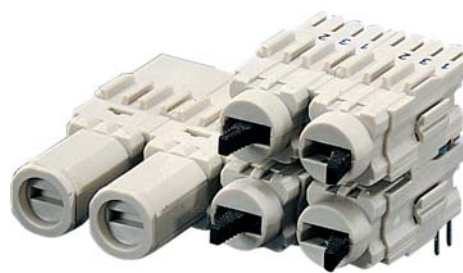

Fuse holders

05092006

Front panel component system

SINGLE LED, LONG TYPE, Ø 3.2 MM

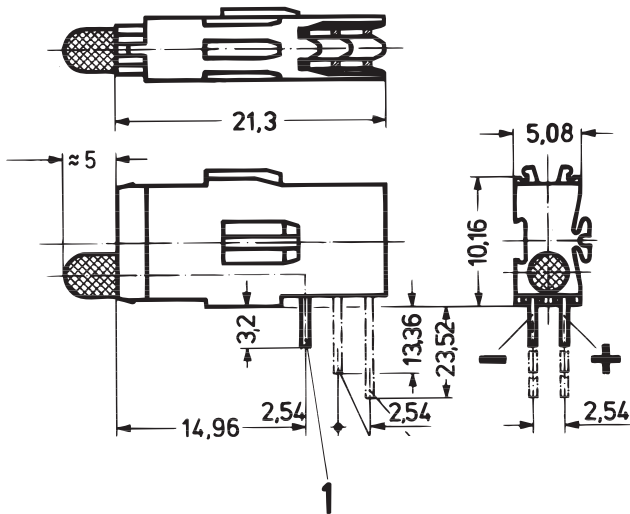

1 = mounting planes

A3-195

- Long type for mounting planes 1

ORDER INFORMATION

Description	Colour	1 Part no.
Low current LED	red	69004-240
Low current LED	yellow	69004-242
Low current LED	green	69004-241
Standard LED	red	69004-059
Standard LED	yellow	69004-065
Standard LED	green	69004-062

Delivery is exclusively in Standard Pack Quantity (SPQ):
Please order at least 10 pieces or a multiple. Pricing is per individual item.

NOTE

- Dimensions of connecting pins: 0.5 × 0.5 mm (mounting plane 1)
- Required front panel drill hole: Ø 4 mm
- Technical data see page 11.17

SINGLE LED, SHORT TYPE, Ø 3.2 MM

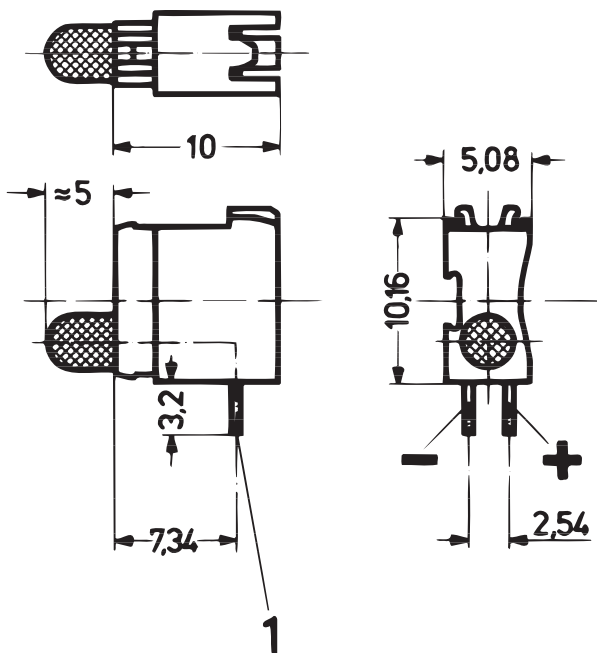

1 = mounting plane

A3-214

- Short type for mounting plane 1

ORDER INFORMATION

Colour	Low current LED Part no.	Standard LED Part no.
red	69004-264	69004-121
yellow	69004-266	69004-123
green	69004-265	69004-122

Delivery is exclusively in Standard Pack Quantity (SPQ):
Please order at least 10 pieces or a multiple. Pricing is per individual item.

NOTE

- Dimensions of connecting pins: 0.5 × 0.5 mm
- Required front panel drill hole: Ø 4 mm
- Technical data see page 11.17

Front panel component system

SINGLE LED, LONG TYPE, Ø 5 MM

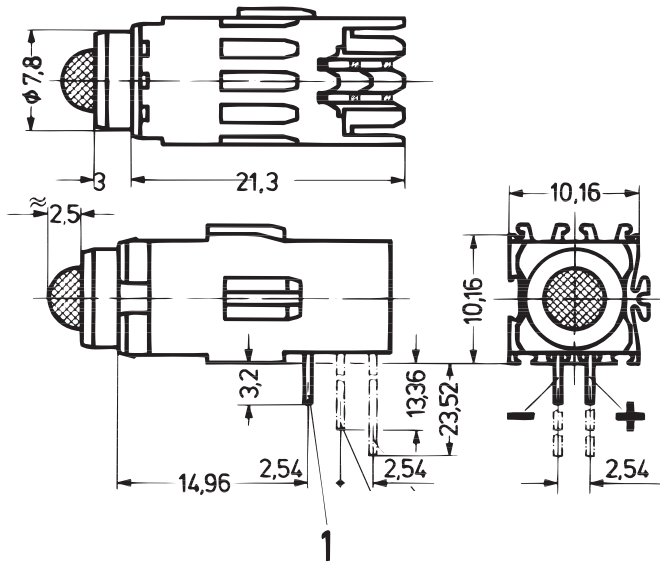

1 = mounting plane

A1-194

- Long type for mounting plane 1

ORDER INFORMATION

Description	Colour	1 Part no.
Low current LED	red	69004-250
Low current LED	yellow	69004-249
Low current LED	green	69004-253
Standard LED	red	69004-050
Standard LED	yellow	69004-056
Standard LED	green	69004-053

Delivery is exclusively in Standard Pack Quantity (SPQ):

Please order at least 10 pieces or a multiple. Pricing is per individual item.

NOTE

- Dimensions of connecting pins: 0.5 x 0.5 mm (mounting plane 1)
- Required front panel drill hole: $\phi 8$ mm
- Technical data see page 11.17

Front panel component system

DOUBLE LED, LONG TYPE, Ø 3.2 MM

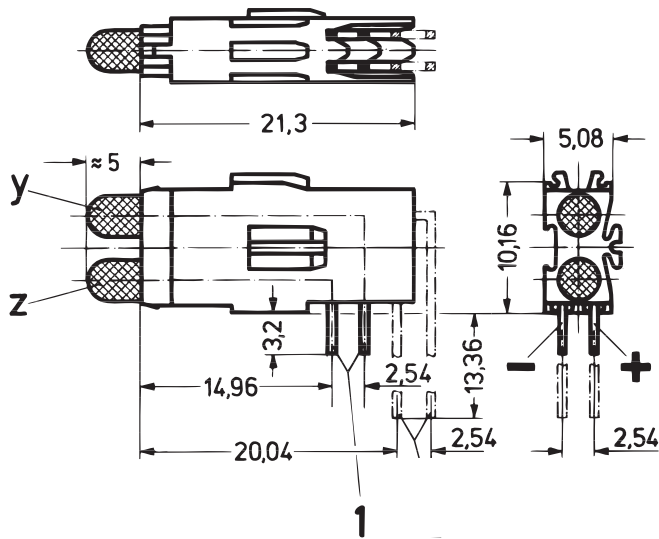

1 = mounting plane

A3-196

- Long type for mounting plane 1

ORDER INFORMATION

Description	Colour	1 Part no.
Standard LED	red/red (Y/Z)	69004-068
Standard LED	green/green (Y/Z)	69004-071
Standard LED	yellow/yellow (Y/Z)	69004-074
Standard LED	red/green (Y/Z)	69004-077

Delivery is exclusively in Standard Pack Quantity (SPQ):
Please order at least 10 pieces or a multiple. Pricing is per individual item.

NOTE

- Dimensions of connecting pins: 0.63 × 0.63 mm
- Required front panel drill hole: Ø 4 mm
- Technical data see page 11.17

DOUBLE LED, SHORT TYPE, Ø 3.2 MM

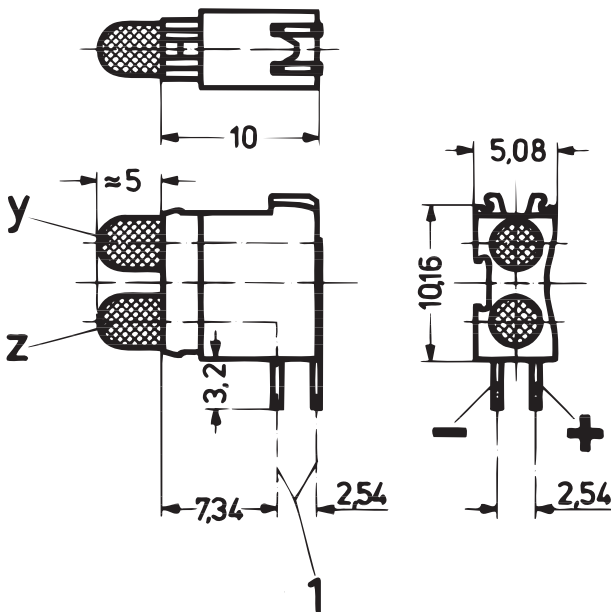

1 = mounting plane

A3-217

- Short type for mounting plane 1

ORDER INFORMATION

Colour	Low current LED Part no.	Standard LED Part no.
red/red (Y/Z)	69004-286	69004-124
yellow/yellow (Y/Z)	69004-288	69004-126
green/green (Y/Z)	69004-287	69004-125
red/green (Y/Z)	69004-289	69004-127
red/yellow (Y/Z)	69004-290	69004-128
yellow/green (Y/Z)	69004-291	69004-129

Delivery is exclusively in Standard Pack Quantity (SPQ):
Please order at least 10 pieces or a multiple. Pricing is per individual item.

NOTE

- Dimensions of connecting pins: 0.5 × 0.5 mm
- Required front panel drill hole: Ø 4 mm
- Technical data see page 11.17

Front panel component system

DIMENSIONS LEDs

A = standard LED
B = low current LED

Absolute maximum data $T_a = 25\text{ °C}$	A red, Ø 3.2 mm		B red, Ø 5 mm		A yellow, Ø 3.2 mm		B yellow, Ø 5 mm		A green, Ø 3.2 mm		B green, Ø 5 mm	
Reverse voltage V	5	3	5	3	5	3	5	3	5	3	5	3
On-state current mA	25	30	25	30	25	30	25	30	25	30	25	30
Power dissipation mW	100	75	100	75	100	75	100	75	100	75	100	75
Forward current mA ($t < 10\text{ }\mu\text{s}$)	100	75	100	75	100	75	100	75	100	75	100	75
Forward voltage V – type (10 mA/2 mA)	2.1	2.1	2.1	2.1	2.1	2.2	2.1	2.2	2.1	2.2	2.1	2.2
– max. (10 mA/2 mA)	3	3	3	3	3	3	3	3	3	3	3	3
Luminous intensity mcd – at 2 mA	–	1.5	–	3.1	–	1.4	–	3.2	–	2	–	3.3
– at 10 mA ¹⁾	1.8	13.4	2.2	25.1	2.7	13.4	3.4	28.6	3.2	24.6	3.9	25.7
– at 20 mA ¹⁾	3.6	26.8	4.4	48.2	5.4	28.7	6.8	60.8	6.4	54.9	7.8	54.6
Wavelength nm (10 mA/2 mA)	635	650	635	650	585	585	585	585	565	563	565	563
Thermal resistance °C/W	400	470	350	390	400	470	350	390	400	470	350	390
Angle of reflected beam	± 50°											
Storage temperature	–55 ... +100 °C											
Operating temperature	–55 ... +100 °C (low-current LED)/–40 ... +85 °C (Standard-LED)											
Solder temperature	260 °C/max. 5 sec (processing advice for wave soldering: protect plastic body against solder wave)											
Insulating body	PBT (Crastin)											
Flammability of insulation body	UL 94 V-0											

1) The low current LEDs can be used from 2 to 20 mA (without reduction of lifespan), which means that a significantly higher luminosity can be achieved.

Front panel component system

TEST SOCKET, Ø 2 MM

Long type

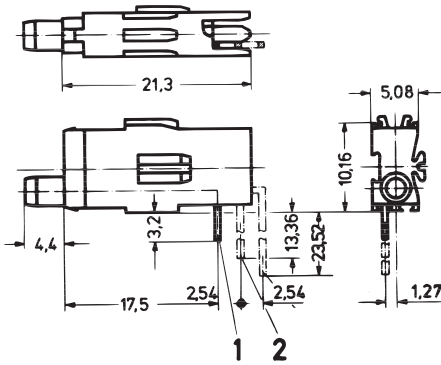

1, 2 = mounting plane

Short type

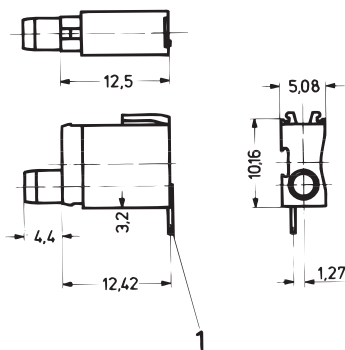

1 = mounting plane

- Long type for mounting plane 1, 2
- Short type for mounting plane 1

ORDER INFORMATION

For application in	1	2
	Part no.	Part no.
Long type	69004-086	69004-087
Short type	69004-130	-

Delivery is exclusively in Standard Pack Quantity (SPQ):
Please order at least 10 pieces or a multiple. Pricing is per individual item.

NOTE

- Dimensions of connecting pins: 0.3 × 0.6 mm
- Required front panel drill hole: Ø 4 mm
- Technical data see page 11.20

A3-199b

KA943

DOUBLE TEST SOCKET, Ø 2 MM

Long type

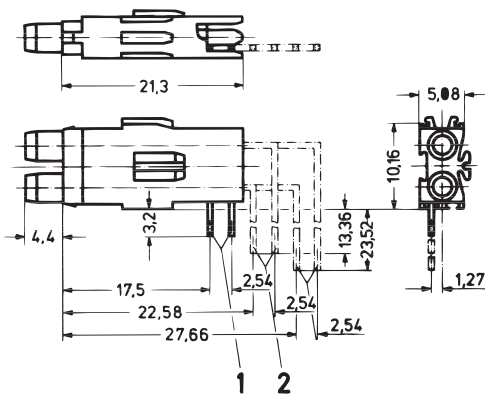

1, 2 = mounting plane

Short type

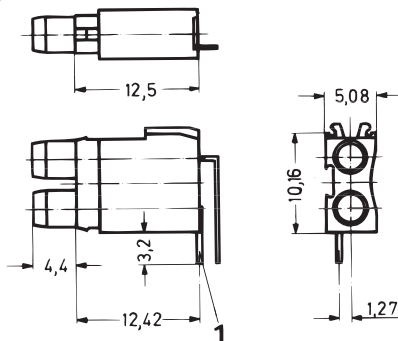

1 = mounting plane

- Long type for mounting plane 1, 2
- Short type for mounting plane 1

ORDER INFORMATION

For application in	1	2
	Part no.	Part no.
Long type	69004-089	69004-090
Short type	69004-131	-

Delivery is exclusively in Standard Pack Quantity (SPQ):
Please order at least 10 pieces or a multiple. Pricing is per individual item.

NOTE

- Dimensions of connecting pins: 0.3 × 0.6 mm
- Required front panel drill hole: Ø 4 mm
- Technical data see page 11.20

05009050

05009051

Front panel component system

DOUBLE MAKE-BREAK SOCKET, Ø 2 MM

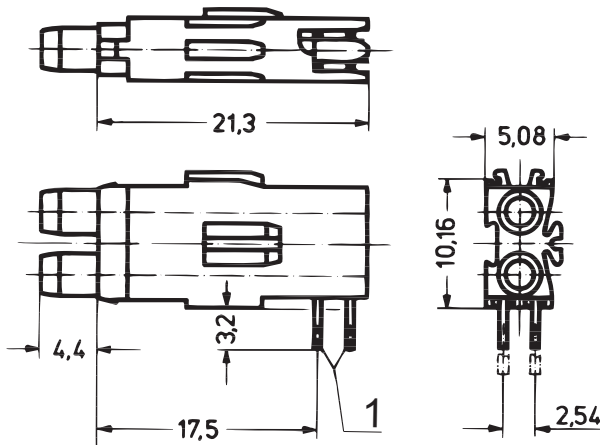

1 = mounting plane

A3-200

- Long type for mounting plane 1
- Gold-plated contacts
- Can also be used as test socket

ORDER INFORMATION

For application in	Part no.
Long type	69004-095

Delivery is exclusively in Standard Pack Quantity (SPQ):
Please order at least 10 pieces or a multiple. Pricing is per individual item.

NOTE

- Dimensions of connecting pins: 0.3 × 0.6 mm
- Required front panel drill hole: Ø 4 mm
- Technical data see page 11.20

Front panel component system

FUSE HOLDER

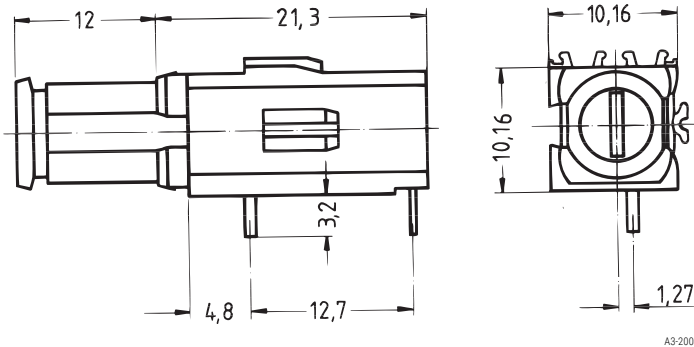

- Long type for mounting plane 1
- For glass fuse inserts 5 x 20 mm to DIN 41 571, 250 V_{AC}, 6.3 A
- Contacts silver-plated

ORDER INFORMATION

Description	Part no.
Long type	69004-098

Delivery is exclusively in Standard Pack Quantity (SPQ): Please order at least 10 pieces or a multiple. Pricing is per individual item.

NOTE

- Dimensions of connecting pins: 0.7 x 0.6 mm
- Required front panel drill hole: Ø 9 mm

	Test socket/make-break socket	Double test socket/ double make-break socket	Fuse holder
Operating voltage	≤ 60 V _{DC/AC}	≤ 30 V _{AC}	≤ 250 V _{AC}
Operating current	≤ 1 A	≤ 1 A	≤ 6.3 A
Test voltage	1 kV/50 Hz	1 kV/50 Hz	–
Temperature range	–25 ... +70 °C	–25 ... +70 °C	–25 ... +70 °C
Solder temperature	260 °C/max. 5 sec (processing advice for wave soldering: protect plastic body against solder wave)		
Contact material	Copper alloy	Copper alloy	Copper alloy
Contact surface	Selectively gold-plated	Selectively gold-plated	Silver-plated
Insulating body	PBT (Crastin)	PBT (Crastin)	PBT (Crastin)
Climatic use category	HSF ¹⁾ to DIN 40 040	HSF ¹⁾ to DIN 40 040	HSF ¹⁾ to DIN 40 040
Flammability	UL 94 V-0	UL 94 V-0	UL 94 V-0

¹⁾ H = –25 °C; S = +70 °C; F = 75 % air humidity, no condensation

Front panel component system

CERMET POTENTIOMETERS

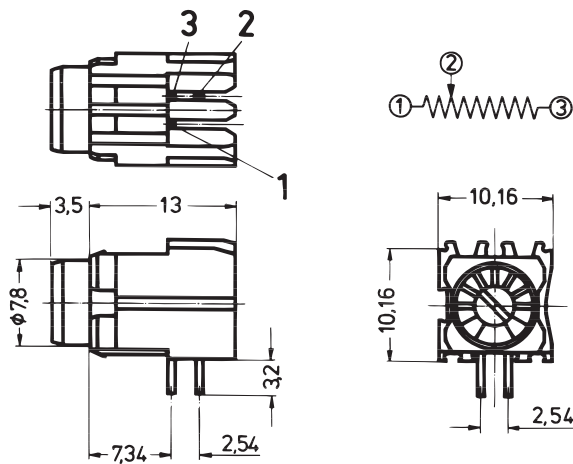

Pins 1 and 2 low-ohmic when left-hinged;
pins 2 and 3 low-ohmic when right-hinged

- Short type for mounting plane 1

ORDER INFORMATION

Resistance kΩ	Part no.
100	69004-155

Delivery is exclusively in Standard Pack Quantity (SPQ):
Please order at least 10 pieces or a multiple. Pricing is per individual item.

TECHNICAL DATA

Operating voltage	≤ 200 V _{DC/AC}
Operating current	≤ 100 mA
Load capacity	0.5 Watt at T _a = 70 °C
Test voltage	500 V/50 Hz
Resistance tolerance	± 10 %
Electrical rotation angle	230° ± 5°
Insulation resistance change	100 MΩ
Contact resistance change	3 Ω or 3 %, use largest value
Torque at initial turning	0.021 Nm
Storage temperature	-55 ... +125 °C
Operating temperature	-25 ... +70 °C
Service life (full rotation)	200 cycles
Service life at 0.5 Watt load	1000 h at T _a = 70 °C
Solder temperature	260 °C/max. 5 sec (processing advice for wave soldering; protect plastic body against solder wave)
Insulating body	PBT (Crastin)
Flammability	UL 94 V-0
Resistance of gasket to cleaning	85 °C max. 1 min.
Temperature coefficient	± 100 ppm/K

NOTE

- Dimensions of connecting pins: 0.45 × 0.45 mm
- Required front panel drill hole: Ø 8 mm
- When left-hinged: pins 1 and 2 low-ohmic
- When right-hinged: pins 2 and 3 low-ohmic

MOUNTING FRAMES WITH PCB BRACKET FOR MOUNTING PLANES

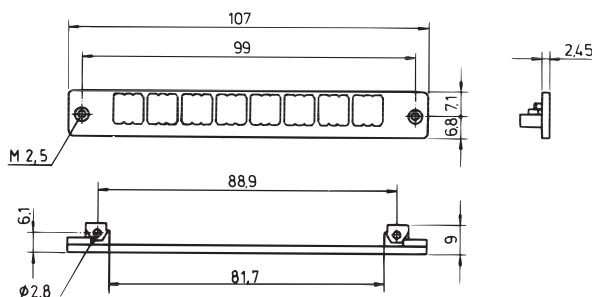

Mounting frame for mounting plane 1

- With 2 threaded female connectors M 2.5
- Material PBT
- Flammability UL 94 V-0

ORDER INFORMATION

Description	Part no.
Mounting frame for mounting plane 1	69004-043

Delivery is exclusively in Standard Pack Quantity (SPQ):
Please order at least 10 pieces or a multiple. Pricing is per individual item

NOTE

- Mounting frame cannot be used in conjunction with the aluminium profile handle for front panels

Front panel component system

DESIGN AIDS

Component side of PCB

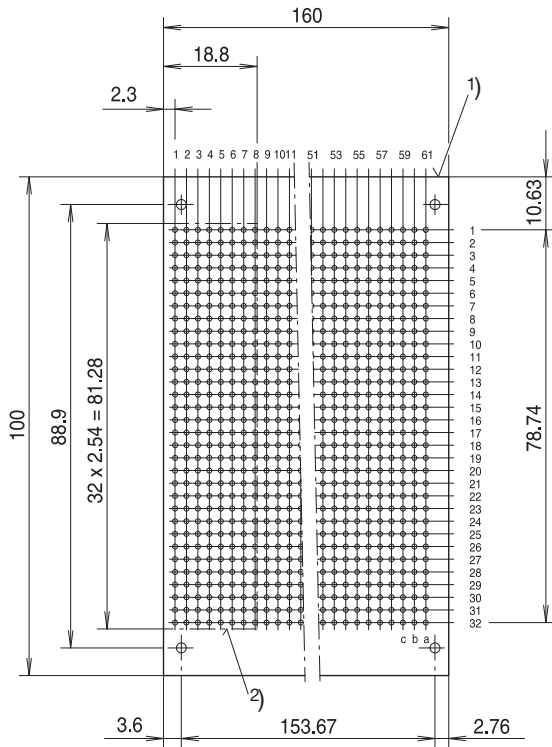

- 1) PCB
- 2) Component mounting limit

FEA45510

Front of front panel

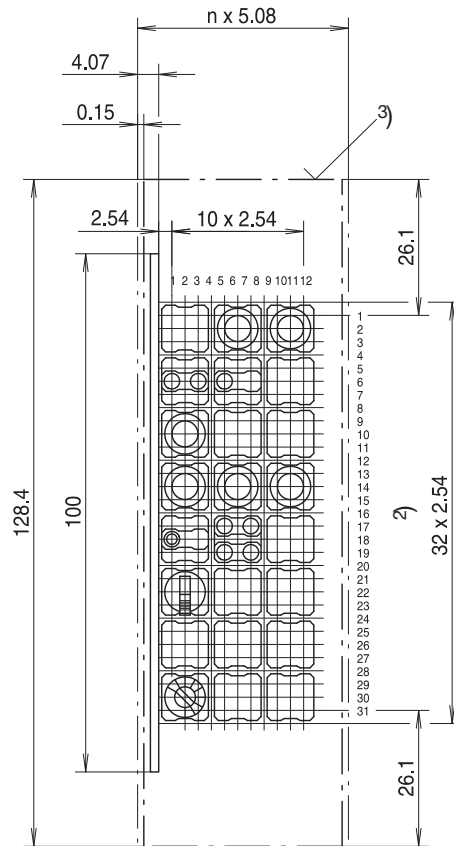

- 3) Front panel

FEA45511

Placement example

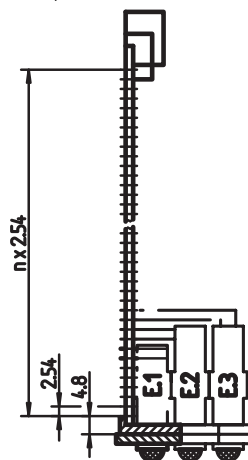

- E1 = first mounting plane
- E2 = second mounting plane
- E3 = third mounting plane

ELA40278

Front panel component system

DESIGN AIDS

PCB tracks
View solder side
Short type
LED,
Ø 3.2 mm

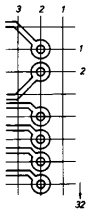

A4_277a

Double LED,
Ø 3.2 mm

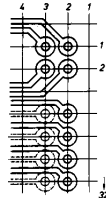

A4_277b

View solder side
Long type
LED,
Ø 3.2 mm

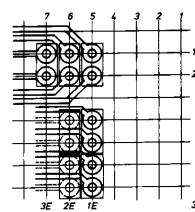

A3_205a

Double LED,
Ø 3.2 mm

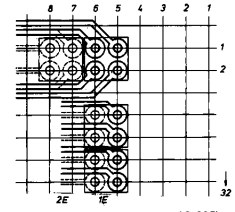

A3_205b

Test socket,
Ø 2 mm

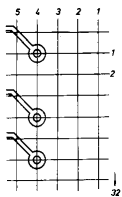

A3_215a

Double test socket,
Ø 2 mm

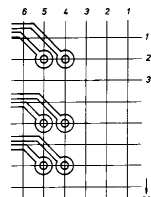

A3_215b

LED,
Ø 5 mm

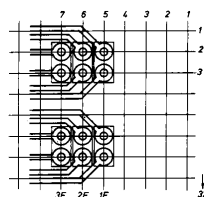

A4_272

Test socket,
Ø 2 mm

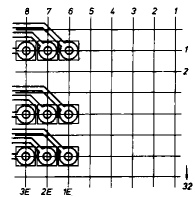

A3_205c

Potentiometer

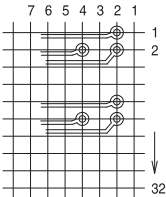

FEA45990

Double test socket,
Ø 2 mm

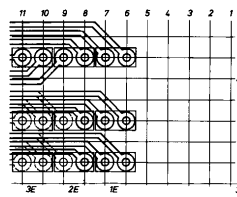

A4_273

Make/break socket,
Ø 2 mm

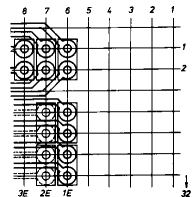

A2_114a

Double make-break socket,
Ø 2 mm

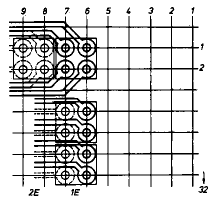

A2_114b

Fuse holder

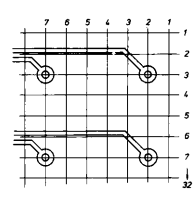

A2_114d

Dimensions of connecting pins	Recommended hole Ø	Solder eyes Ø
0.5 × 0.5 mm	1.0 mm ± 0.05	2.1 mm ± 0.1
0.63 × 0.63 mm	1.1 mm ± 0.05	2.2 mm ± 0.2
0.3 × 0.6 mm	0.9 mm ± 0.05	2.0 mm ± 0.2
0.7 × 0.6 mm	1.1 mm ± 0.05	2.1 mm ± 0.2
0.4 × 0.6 mm	0.9 mm ± 0.05	2.0 mm ± 0.2
0.45 × 0.45 mm	0.7 mm ± 0.05	1.8 mm ± 0.2

PCB tracks width min. 0.6 mm
Grid 2.54 mm

North America

Warwick, RI, USA

Tel +1.800.525.4682

San Diego, CA, USA

Tel +1.800.854.7086

Europe, Middle East & India

Straubenhardt, Germany

Tel +49 7082 794 0

Betschdorf, France

Tel +33 3 88 90 64 90

Warsaw, Poland

Tel +48 22 209 98 35

Hemel Hempstead,

Great Britain

Tel +44 1442 24 04 71

Lainate, Italy

Tel +39 02 932 714 1

Dubai, United Arab Emirates

Tel +971 4 37 81 700

Bangalore, India

Tel +91 80 67152000

Istanbul, Turkey

Tel +90 216 250 7374

Asia Pacific

Shanghai, China

Tel +86 21 2412 6943

Singapore

Tel +65 6768 5800

Shin-Yokohama, Japan

Tel +81 45 476 0271

Our powerful portfolio of brands:

CADDY ERICO HOFFMAN RAYCHEM SCHROFF TRACER



[nVent.com/SCHROFF](https://www.nVent.com/SCHROFF)