

Ultimaker S5

Specification sheet

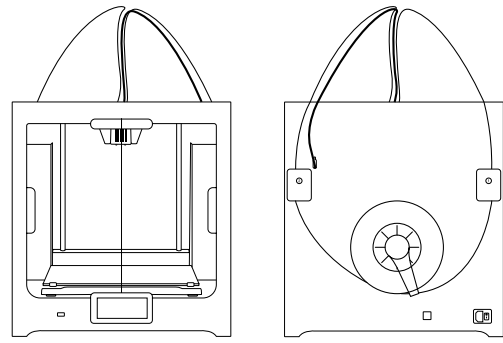

The Ultimaker S5 is built to run continuously and maximize uptime. It not only delivers best-in-class technical specifications for a desktop 3D printer, but gives you the performance and peace of mind that comes with using the complete 3D printing solution – one trusted by hundreds of thousands of professionals worldwide.



Reliable dual extrusion on a bigger scale

Print large, intricate designs with new confidence, using the Ultimaker S5's reliable dual extrusion technology and enhanced active leveling. Our wide range of engineering and support materials provide complete design freedom – with minimal post-processing.



Open and connected system

The Ultimaker S5's connectivity means connecting multiple printers together over Wi-Fi is easy, while NFC technology automatically recognizes the loaded material. An open system enables the use of third-party materials and the seamless integration of Ultimaker Cura with your existing software.



Market-leading software

Trusted by over 2 million users, Ultimaker Cura software prepares your 3D model for printing. Free to download, it features the optimal preconfigured settings for Ultimaker printers and materials, so that you get the best results instantly.



Optimized materials for high-end applications

Ultimaker S5 leverages our full material portfolio. These materials are formulated and tested by our engineers to create industrial-grade prints. And with print core CC Red, you can also print using the world's most advanced composite filaments.



Here to help you succeed

The Ultimaker S5 comes with a one-year warranty and lifetime support from our trained and certified global network of partners. And if you have a question, our online resources and community are there for you 24/7.

Ultimaker S5 specifications

Printer and printing properties	Technology	Fused filament fabrication (FFF)
	Print head	Dual extrusion print head with a unique auto-nozzle lifting system and swappable print cores
	Build volume	XYZ: 330 x 240 x 300 mm (left or right nozzle, or dual extrusion)
	Filament diameter	2.85 mm
	Layer resolution	0.25 mm nozzle: 150 - 60 micron 0.4 mm nozzle: 200 - 20 micron 0.6 mm nozzle: 300 - 20 micron 0.8 mm nozzle: 600 - 20 micron
	XYZ resolution	6.9, 6.9, 2.5 micron
	Build speed	< 24 mm ³ /s
	Build plate	Heated glass build plate
	Build plate temperature	20 - 140 °C
	Build plate leveling	Active leveling
	Build plate heat up time	< 4 min (from 20 to 60 °C)
	Supported materials	Optimized for PLA, Tough PLA, ABS, Nylon, CPE, CPE+, PC, PP, TPU 95A, PVA, Breakaway (Also supports third-party materials) In the box: Ultimaker Tough PLA Black 750 g, Ultimaker PVA 750 g
	Feeder type	Dual-gear, abrasion-resistant (ready for composite materials)
	Nozzle diameter	0.25 mm, 0.4 mm, 0.6 mm, 0.8 mm
	Nozzle temperature	180 - 280 °C
	Nozzle heat up time	< 2 min
	Operating sound	< 50 dBA
	Maximum power output	500 W
	Material recognition	Auto-recognition with NFC scanner
	Connectivity	Wi-Fi, LAN, USB port
	Display	4.7-inch (11.9 cm) color touchscreen
Language support	English, Dutch, French, German, Italian, Japanese, Korean, Portuguese, Russian, Spanish, Simplified Chinese	
Monitoring	Live camera (view from desktop or Ultimaker app)	
Physical dimensions	Dimensions	495 x 457 x 520 mm 495 x 585 x 780 mm (with Bowden tubes and spool holder)
	Net weight	20.6 kg
	Shipping weight	29 kg
	Shipping box dimensions	650 x 600 x 700 mm
Ambient conditions	Operating ambient temperature	15 - 32 °C, 10 - 90% RH non-condensing
	Non-operating temperature	0 - 32 °C
Software	Supplied software	Ultimaker Cura, our free print preparation software Cura Connect, our free printer management solution
	Supported OS	MacOS, Windows, and Linux
	Plugin integration	SolidWorks, Siemens NX, Autodesk Inventor
	File types	Ultimaker Cura: STL, OBJ, X3D, 3MF, BMP, GIF, JPG, PNG Printable formats: G, GCODE, GCODE.gz, UFP
Warranty and service	Warranty period	12 months
	Technical support	Lifetime support from Ultimaker's global network of certified service partners



STORAGE

XSTRAND™ filaments must be stored in a dry and temperate location. The product should remain in its original packaging, preferably closed, until beginning of use.

WARNING

When melted, XSTRAND™ filament can be abrasive due to its glass reinforcement. Printing with XSTRAND™ may reduce brass nozzles and extruder driving wheels' lifetime. For a better experience, using hardened steel nozzles and extruder driving wheels is advised.

Ensure sufficient ventilation in your 3D printing space and avoid inhaling extrusion fumes.

CONTACT

For any questions related to XSTRAND™ 3D products, contact us at:

3dprinting@owenscorning.com

Material Safety Data Sheet available upon request.

This information and data contained herein is offered solely as a guide in the selection of reinforcement. Rating contained in this publication is based on actual laboratory data, field test experience and observation of overall market use. We believe this information to be reliable, but do not guarantee its applicability to the user's process or assume any responsibility or liability arising out of its use or performance. The user agrees to be responsible for thoroughly testing any application to determine its suitability before committing to production. It is important for the user to determine the properties of its own commercial compounds when using this or any other reinforcement. Because of numerous factors affecting results, we make no warranty of any kind, express or implied, including those of merchantability and fitness for a particular purpose. Statements in this publication shall not be construed as representations or warranties or as inducements to infringe any patent or violate any law safety code or insurance regulation. Owens Corning reserves the right to modify this document without prior notice. Copyright © 2018 Owens Corning. All Rights Reserved. Pub. 10022733. XSTRAND™ 3D GF30-PA6 Technical datasheet Rev2 January 2018



Revision date: January 22nd, 2018

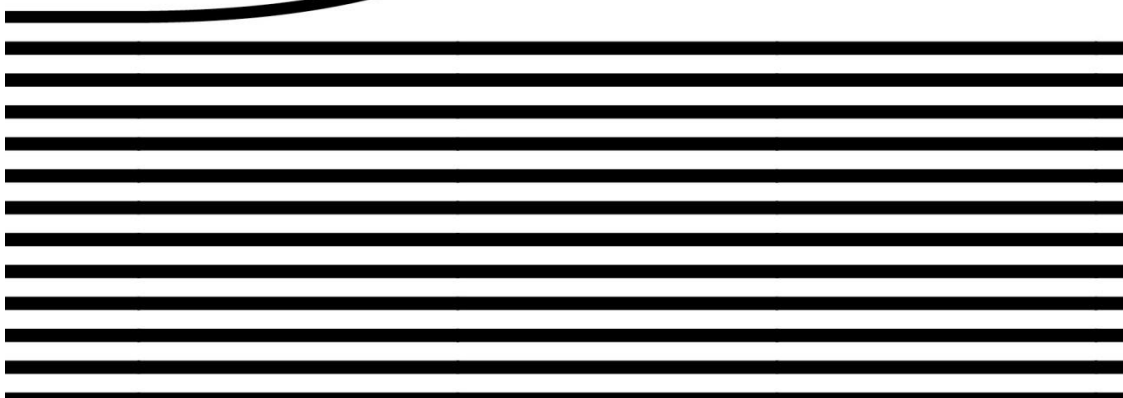

3D FILAMENT
GLASS FIBER REINFORCED POLYAMIDE 6
GF30-PA6



MATERIAL DATASHEET

Physical Properties	Metric	Imperial	Standard
Density	1,17 g/cm ³	9,76 lbs/gal	ISO 1183-A
Moisture Absorption	0,58 %	0,58 %	ISO 62 23 °C / 50% RH
Water Absorption	9,62 %	9,62 %	ISO 62 23 °C / Sat

Mechanical Properties	Metric	Imperial	Standard
Tensile Modulus	7 400 MPa	1,074 ksi	ISO 527 1 mm/min (0.04 inch/min)
Tensile Strength (Yield)	102 MPa	14,800 psi	ISO 527 1 mm/min (0.04 inch/min)
Tensile Strength (Break)	102 MPa	14,800 psi	ISO 527 1 mm/min (0.04 inch/min)
Elongation (Break)	2.1 %	2.1 %	ISO 527 1 mm/min (0.04 inch/min)
Flexural Modulus	6 100 MPa	880 ksi	ISO 178 2 mm/min (0.08 inch/min)
Flexural Strength (Yield)	170 MPa	24,600 psi	ISO 178 2 mm/min (0.08 inch/min)
Flexural Strength (Break)	166 MPa	24,100 psi	ISO 178 2 mm/min (0.08 inch/min)

Thermal Properties	Metric	Imperial	Standard
Heat Deflection Temperature	124 °C	255 °F	ISO 75 Method A (1.8 MPa)
Melting Temperature	206 °C	403 °F	ISO 11357

Printer Settings	Nozzle	Bed	Recommended Bed Type
Temperature	220 °C - 280 °C	80 °C - 110 °C	1) Perforated bed 2) PEI flat plate
Printing speed	30-100 mm/s	-	3) PI (Kapton) adhesive
Nozzle diameter	> 0.4 mm	-	

PACKAGING

Thermal Properties	Metric	Imperial	Standard
Filament diameter	1,75 mm / 2,85 mm	0,069 inch / 0,112 inch	+/- 0,05 mm
Material weight	500 g / 2200 g	1.1 lbs / 4.85 lbs	Net weight
Spool (500g / 1.1lbs)	200 / 52 / 55 mm	7.9 / 2.0 / 2.2 inch	∅ext / ∅int / width
Spool (2200g / 4.85 lbs)	300 / 52 / 102 mm	11.8 / 2.0 / 4.0 inch	∅ext / ∅int / width

DESCRIPTION

Developed by Owens Corning, a world leader in composite solutions, XSTRAND™ GF30-PA6 filament for 3D printing is a reinforced material designed to be compatible with any standard Fused Filament Fabrication 3D printer (1.75 and 2.85 mm diameters available).

BENEFITS

- Very high stiffness and strength (up to +250% compare to ABS)
- Large operational temperature range (-20°C to 120°C)
- Good chemical and UV resistance
- High wear resistance
- Excellent layer adhesion
- Reduced warping effect compared to neat PA6

POTENTIAL APPLICATIONS

XSTRAND™ GF30-PA6 is designed for functional prototyping and demanding applications such as industrial tooling, transportation, electronics, small appliances, sports & leisure...