

## 2.3" Single Digit Full Colour Common Anode 7 Segment LED Display

**multicomp** PRO

**RoHS  
Compliant**

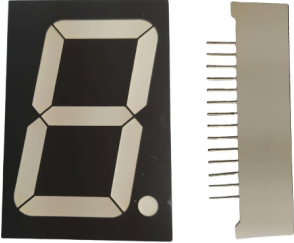

### Specifications

Dice Material	: AlInGaP / InGaN / InGaN
Emitted Colour	: Super Orange Red / Ultra Green / Super Blue
Epoxy Colour	: White Diffused
Peak Wavelength	: 635nm / 525nm / 470nm
Surface Ink Colour	: Black
Luminous Intensity (IV)	: 20mcd / 25mcd / 18mcd

### Electrical / Optical Characteristics at TA = 25°C

Parameter	Symbol	Min.	Typ. R/G/B	Max.	Unit	Test
Luminous Intensity	IV	15/20/14	20/25/18	25/30/22	mcd	IF = 20mA
Viewing Angle	2θ1/2	-	-	-	Deg.	
Peak Emission Wavelength	λp		635/525/470		nm	
Dominant Wavelength	λD	620/517/464	625/525/467	630/530/472	nm	
Spectral Line Half-Width	Δλ		45/36/40		nm	
Forward Voltage	VF*	1.8/2.8/2.8	2/3.1/3.1	2.4/3.5/3.5	V	
Reverse Current	I <sub>r</sub>	-	-	10	μA	VR=5V

▲ Luminous intensity (IV) ±10%, Forward Voltage (VF) ±0.1V, Wavelength (λd) ±0.5nm

\* Forward Voltage For One Chip

### Absolute Maximum Ratings (TA = 25°C)

Parameter	Symbol	Rating
Power Dissipation	Pd	85mW
Peak Forward Current (Duty 1/10 @ 1kHz)	IF (Peak)	100mA
Recommended Operating Current	IF (Rec)	30mA
Electrostatic Discharge	ESDHBM	200V
Operating Temperature Range	T <sub>OPR</sub>	-40°C to +85°C
Storage Temperature Range	T <sub>STG</sub>	-40°C to +100°C
Lead Soldering Temperature Range (1.6mm (1/16 inch) from body)		Reflow Soldering : 260°C for 5 sec. Hand Soldering : 350°C for 3 sec.

Newark.com/multicomp-pro  
Farnell.com/multicomp-pro  
Element14.com/multicomp-pro

**multicomp** PRO

# 2.3" Single Digit Full Colour Common Anode 7 Segment LED Display



## Typical Electro-Optical Characteristics Curves

Super Orange (AlInGaP  $\lambda_P = 635\text{nm}$ )

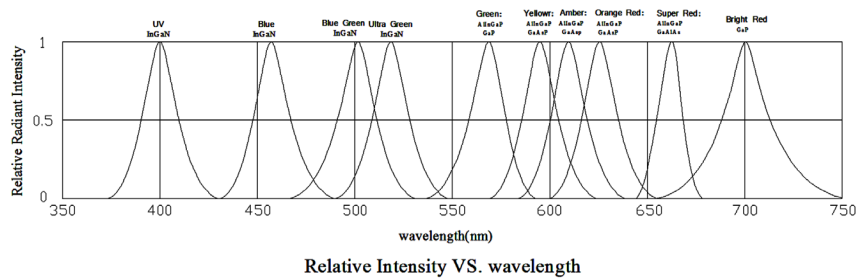
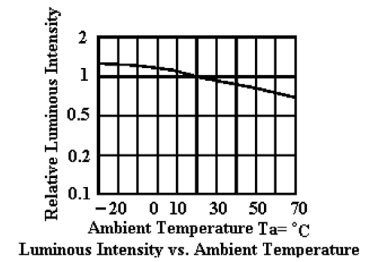
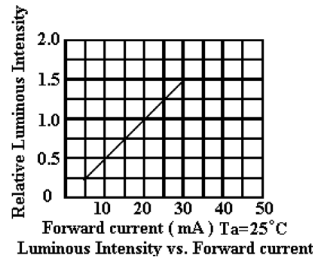
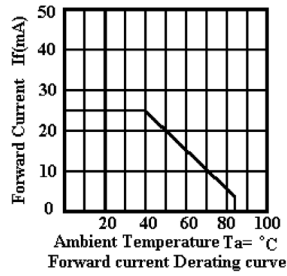
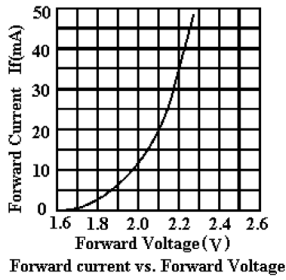

Ultra Green (InGaN  $\lambda_P = 525\text{nm}$ )

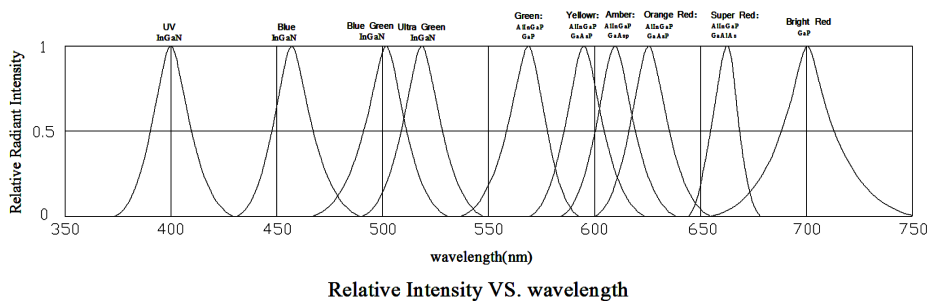
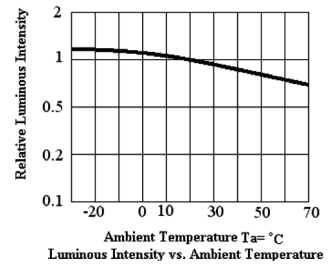
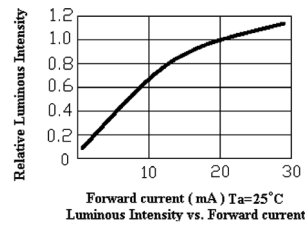
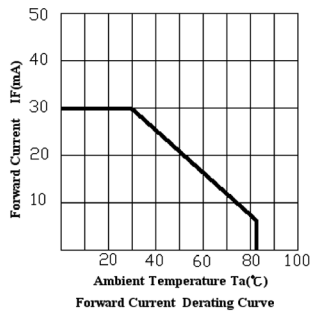
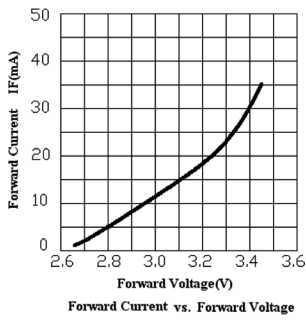

# 2.3" Single Digit Full Colour Common Anode 7 Segment LED Display



## Super Blue (InGaN $\lambda_P = 470\text{nm}$ )

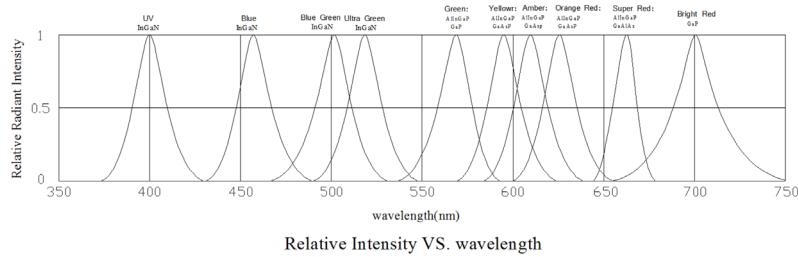
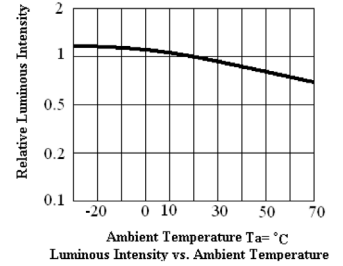
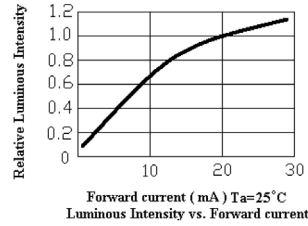
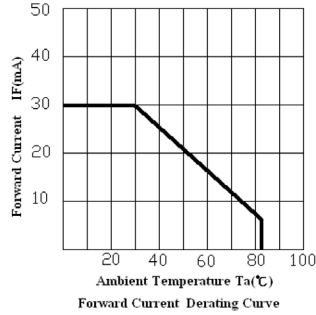
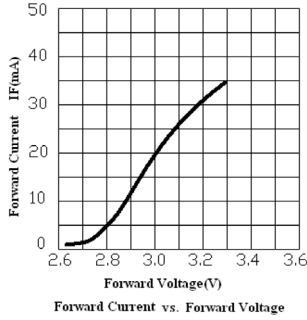

## Soldering

Recommended soldering condition as shown below:

### Soldering heat (DIP)

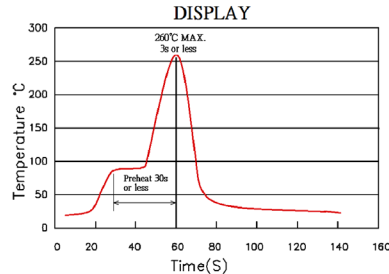
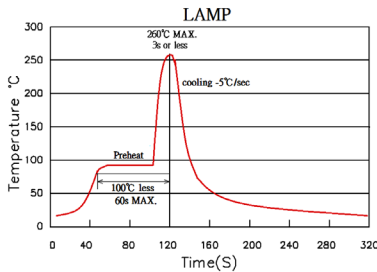

### Soldering Iron

Temperature at tip of iron : 350°C Max.

Soldering Time: 3 sec.  $\pm 1$ sec. (one time only) If temperature is higher, time should be shorter

### Reflow Temp./Time (SMD)

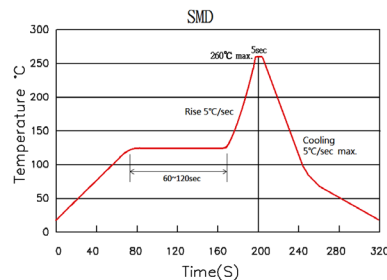

Newark.com/multicomp-pro  
Farnell.com/multicomp-pro  
Element14.com/multicomp-pro



# 2.3" Single Digit Full Colour Common Anode 7 Segment LED Display



## Diagram

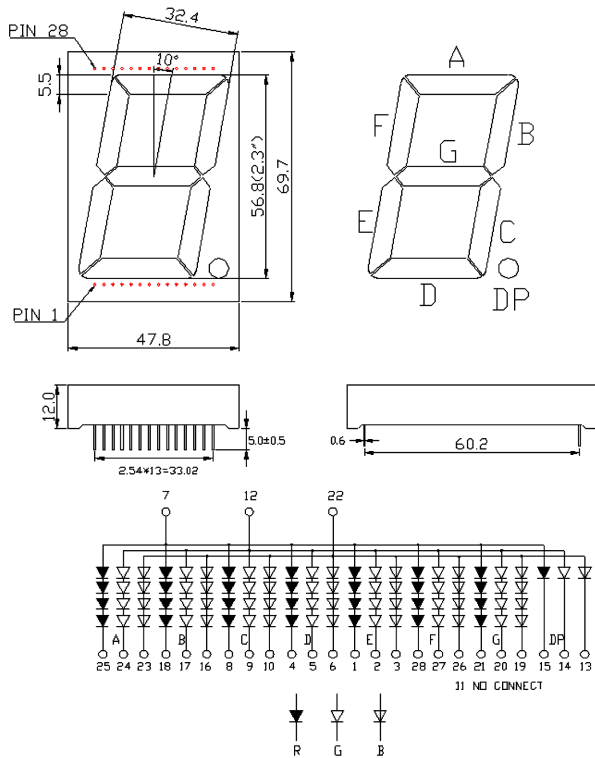

Dimensions : Millimetres  
Tolerance:  $\pm 0.25\text{mm}$

## Part Number Table

Description	Part Number
7 Segment LED Display, Single Digit, 2.3", Common Anode	MP005916

**Important Notice :** This data sheet and its contents (the "Information") belong to the members of the AVNET group of companies (the "Group") or are licensed to it. No licence is granted for the use of it other than for information purposes in connection with the products to which it relates. No licence of any intellectual property rights is granted. The Information is subject to change without notice and replaces all data sheets previously supplied. The Information supplied is believed to be accurate but the Group assumes no responsibility for its accuracy or completeness, any error in or omission from it or for any use made of it. Users of this data sheet should check for themselves the Information and the suitability of the products for their purpose and not make any assumptions based on information included or omitted. Liability for loss or damage resulting from any reliance on the Information or use of it (including liability resulting from negligence or where the Group was aware of the possibility of such loss or damage arising) is excluded. This will not operate to limit or restrict the Group's liability for death or personal injury resulting from its negligence. Multicomp Pro is the registered trademark of Premier Farnell Limited 2019.

Newark.com/multicomp-pro  
Farnell.com/multicomp-pro  
Element14.com/multicomp-pro

