



Main

Range of product	Harmony Relay
Product or component type	Solid state relay
Provided accessory	Thermal pad
Device short name	SSP1
Mounting support	Panel
Number of phases	1 phase
Contacts type and configuration	1 NO
[In] rated current	50 A
Solid state output type	Zero voltage switching SCR output

Complementary

[Uc] control circuit voltage	4...32 V DC
Minimum switching voltage	4 V DC turn-on
Maximum switching voltage	1 V DC turn-off
Response time	0.5 cycle (turn-on) 0.5 cycle (turn-off)
Input current	10 mA at 12 V DC
Output voltage	24...300 V AC
Load current	0.15...50 A
Transient overvoltage	600 V
Surge current	625 A for 16.6 ms
Maximum I ² t for fusing	1621 A ² .s for 8.33 ms at 60 Hz 1770 A ² .s for 10 ms at 50 Hz
Co-ordination type	Type 1 - 40 A miniature circuit breaker (MCB) - curve B Type 2 - 32 A miniature circuit breaker (MCB) - curve B
Maximum leakage current	1 mA off-state

Maximum voltage drop	<1.15 V on-state
DV/Dt	500 V/ μ s off-state at maximum voltage
Power factor	0.5 (with maximum load)
Motor controller rating	0.75 hp 120 V AC 2 hp 240 V AC
Insulation resistance	1000 MOhm at 500 V DC
Maximum capacitance	10 pF for input/output
Dielectric strength	4 kV AC for input/output 4 kV AC for input or output to case
[Uimp] rated impulse withstand voltage	6 kV output to case 6 kV input to output
Tightening torque	1.5...1.7 N.m for input 2...2.2 N.m for output 17.7...19.47 lb.in for output 13.27...15.04 lb.in for input 0.5...0.6 N.m for auxillary terminal 4.4...5.3 lb.in for auxillary terminal
Connections - terminals	Screw terminals: 0.2...3.3 mm ² , (AWG 24...AWG 12) with cable end for input Screw terminals: 0.5...5.26 mm ² , (AWG 20...AWG 10) with cable end for output Screw terminals: 0.2...3.3 mm ² , (AWG 24...AWG 12) without cable end for input Screw terminals: 0.5...8.26 mm ² , (AWG 20...AWG 8) without cable end for output Forked type tag connectors: 9.2 x 4 mm for input Ring lugs: 9.2 x 4 mm for input Forked type tag connectors: 11.7 x 4.5 mm for output Ring lugs: 11.7 x 4.5 mm for output
Auxiliary/Alarm connection terminal	Screw-type connector, 0.5...1.5 mm ² (AWG 20...AWG 16) with slotted Philips screwdriver
Thermal resistance	0.45 °C/W junction to case
LED indicator	LED, steady, green for ON status for control input/test button actuated LED, steady, amber for ON status for load LED, flashing, amber for control input to energise load LED, steady, red for open-circuit for control input LED, flashing, red for load cut-off/short-circuit
Maximum alarm output current	30 mA at 32 V DC
Minimum load current	150 mA
IP degree of protection	IP20
Electromagnetic compatibility	Electrostatic discharge 6 kV criteria A contact discharge conforming to IEC 61000-4-2 Electrostatic discharge 8 kV criteria A air discharge conforming to IEC 61000-4-2 Radiated radio-frequency electromagnetic field immunity test criteria A output ports conforming to IEC 61000-4-3 Radiated radio-frequency electromagnetic field immunity test criteria B alarm port conforming to IEC 61000-4-3 Electrical fast transient/burst immunity test 1 kV, 5/100 kHz criteria B output ports conforming to IEC 61000-4-4 Surge immunity test 1 kV criteria A output ports line to line conforming to IEC 61000-4-5 Surge immunity test 2 kV criteria A output ports line to earth conforming to IEC 61000-4-5
Safety reliability data	B10d = 1731395 MTTFd = 1875.9 years
Net weight	97.1 g
Device presentation	Complete product

Environment

Ambient air temperature for operation	-40...80 °C
Ambient air temperature for storage	-40...125 °C
Pollution degree	2
Overvoltage category	III
Product certifications	CSA CE REACH RoHS EAC UL
Marking	EAC UL

	CSA CE
Standards	EN/IEC 60950-1 EN/IEC 62314 UL 508 CSA C22.2 No 14-13

Packing Units

Package 1 Weight	0.100 kg
Package 1 Height	0.460 dm
Package 1 width	0.450 dm
Package 1 Length	0.590 dm

Offer Sustainability

Sustainable offer status	Green Premium product
REACH Regulation	REACH Declaration
EU RoHS Directive	Pro-active compliance (Product out of EU RoHS legal scope) EU RoHS Declaration
Mercury free	Yes
RoHS exemption information	Yes
China RoHS Regulation	China RoHS declaration
Environmental Disclosure	Product Environmental Profile
Circularity Profile	End of Life Information

Dimensions

mm
in.

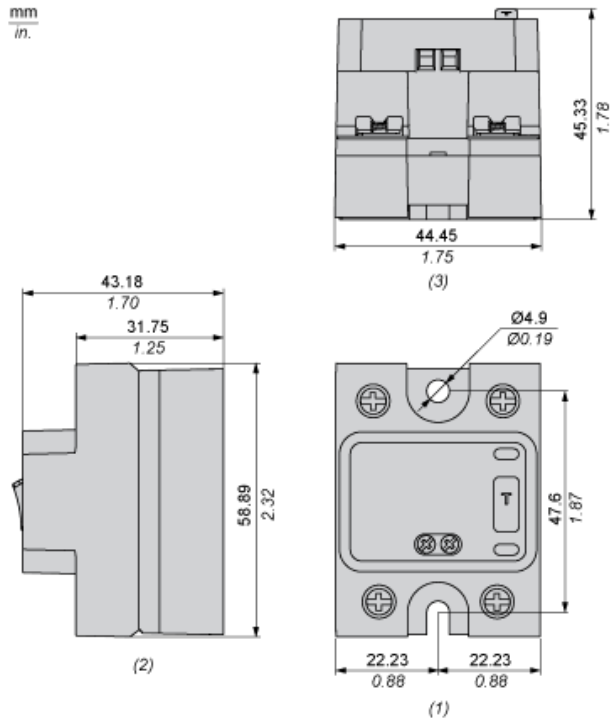

- (1) Front view
- (2) Side view
- (3) Bottom view

Wiring Diagram

Single Supply Connection

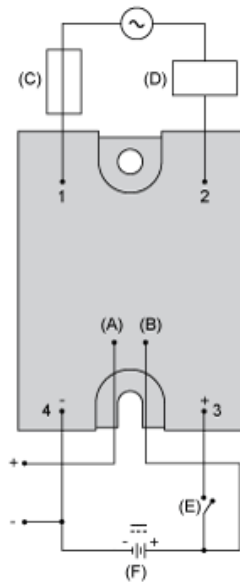

- (F) Control/Auxiliary supply (4...32 V DC)
- (A) Alarm output terminal (4...32 V DC)
- (B) Auxiliary supply terminal
- (C) Fuse or circuit-breaker
- (D) Load
- (E) Switch to energize load

Dual Supply Connection

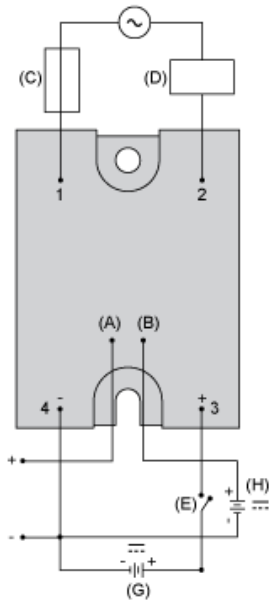

- (G) Control supply (4...32 V DC)
- (H) Auxiliary supply (4...32 V DC)
- (A) Alarm output terminal (4...32 V DC)
- (B) Auxiliary supply terminal
- (C) Fuse or circuit-breaker
- (D) Load
- (E) Switch to energize load

Derating Curves

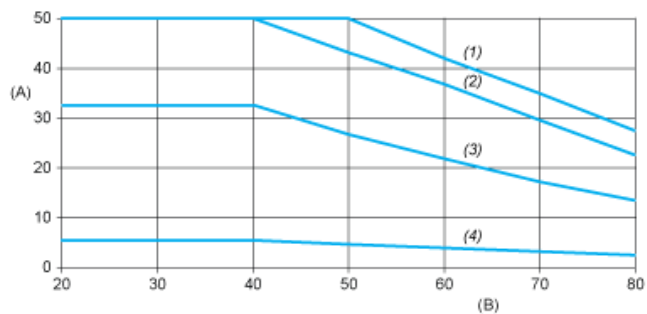

- A : Load Current (Arms)
- B : Ambient Temperature (°C)
- (1) For Heatsink SSRHP07
- (2) For Heatsink SSRHD10
- (3) For Heatsink SSRHP17
- (4) No Heatsink