

DOCUMENT NUMBER AND REVISION

VL-FS-BTHQ 21608VSS-04 REV. A
(BTHQ 21608VSS-STF-06-LEDYG)

DOCUMENT TITLE:

SPECIFICATION
OF
LCD MODULE TYPE

CUSTOMER	DATA MODUL
MODEL NUMBER	BTHQ 21608VSS-04
CUSTOMER APPROVAL	
DATE	

DEPARTMENT	NAME	SIGNATURE	DATE
PREPARED BY	SUNNY LEE	<i>Sunny Lee</i>	2003.3.12
CHECKED BY	ZHOU CHUN HUA	<i>zhouchunhua</i>	2003.3.13
APPROVED BY	DERRICK TAM	<i>Derrick</i>	2003.3.14

DISTRIBUTION LIST: MARKETING

DOCUMENT REVISION HISTORY 1:

DOCUMENT REVISION FROM TO	DATE	DESCRIPTION	CHANGED BY	CHECKED BY
A	2003.3.11	First Release.	SUNNY LEE	ZHOU CHUN HUA

CONTENTS

	<u>Page No.</u>
1. GENERAL DESCRIPTION	4
2. MECHANICAL SPECIFICATIONS	4
3. INTERFACE SIGNALS	6
4. ABSOLUTE MAXIMUM RATINGS	7
4.1 ELECTRICAL MAXIMUM RATINGS (Ta=25°C)	7
4.2 ENVIRONMENTAL CONDITION	7
5. ELECTRICAL SPECIFICATIONS	8
5.1 TYPICAL ELECTRICAL CHARACTERISTICS	8
5.2 TIMING SPECIFICATIONS	9
5.3 TIMING DIAGRAM OF VDD AGAINST V0	11
6. CGROM CHARACTER CODE TABLE	12

**Specification
of
LCD Module Type
Model No.: BTHQ 21608VSS-04**

1. General Description

- ⚡ 16 characters (5x8 dots) x 2 lines STN Positive Yellow Transflective Dot Matrix LCD module.
- ⚡ Viewing Angle: 6 O'clock direction.
- ⚡ Driving scheme: 1/16 Duty, 1/5 bias.
- ⚡ 'SAMSUNG' KS0070BP-00CC (Die form) LCD Controller & Driver or equivalent.
- ⚡ Yellow-green LED04 backlight.

2. Mechanical Specifications

The mechanical detail is shown in Fig. 1 and summarized in Table 1 below.

Table 1

Parameter	Specifications	Unit
Outline dimensions	122.0(W) x 43.0(H) x 15.0 MAX.(D)	mm
Effective viewing area	99.0(W) x 23.0(H)	mm
Display format	16 characters x 2 lines	-
Character size	4.84(W) x 9.22(H) (5 x 8 dots)	mm
Character spacing	1.16(W) x 0.53(H)	mm
Character pitch	6.00(W) x 9.75(H)	mm
Dot size	0.956(W) x 1.139(H)	mm
Dot spacing	0.015(W) x 0.015(H)	mm
Dot pitch	0.971(W) x 1.154(H)	mm
Weight:	Approx. 66.0	Grams

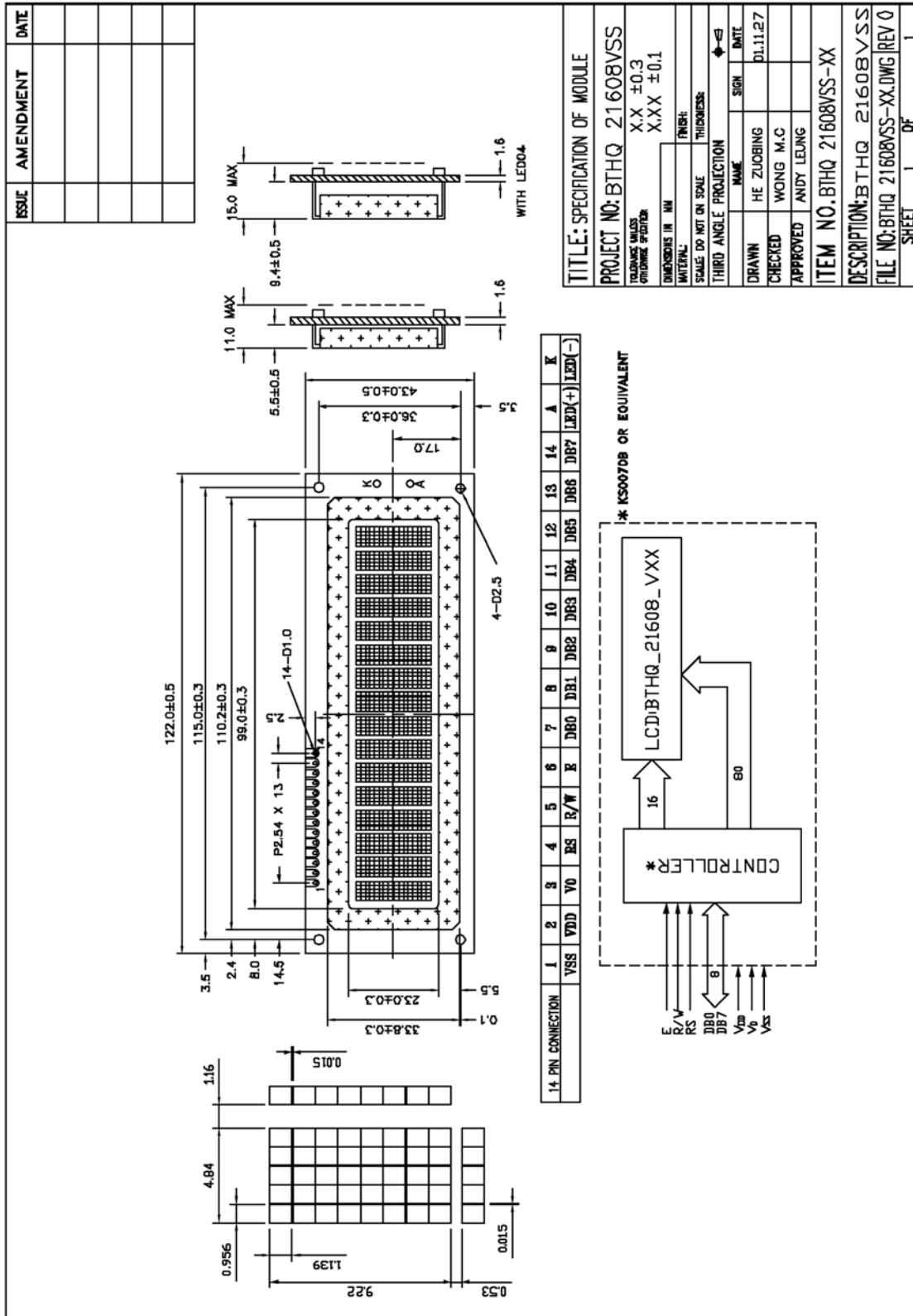

3. Interface signals

Table 2

Pin No.	Symbol	Description
1	VSS	Ground (0V).
2	VDD	Power supply for logic (+5V)
3	V0	Power supply for LCD driver
4	RS	Register Select Input: “High” for Data register (for read and write) “Low” for Instruction register (for write), Busy flag, address counter (for read)
5	R/W	Read/Write signal: “High” for Read mode. “Low” for Write mode.
6	E	Enable. Start signal for data read /write.
7	DB0	Data input/output (LSB)
8	DB1	Data input/output
9	DB2	Data input/output
10	DB3	Data input/output
11	DB4	Data input/output
12	DB5	Data input/output
13	DB6	Data input/output
14	DB7	Data input/output (MSB)
A	LED(+)	Anode of LED backlight
K	LED(-)	Cathode of LED backlight

4. Absolute Maximum Ratings

4.1 Electrical Maximum Ratings (Ta = 25 °C)

Table 3

Parameter	Symbol	Min.	Max.	Unit
Power Supply voltage (Logic)	VDD - VSS	-0.3	+7.0	V
Power Supply voltage (LCD drive)	VLCD=VDD – V0	-0.3	+15.0	V
Input voltage	Vin	-0.3	VDD +0.3	V

Note:

The modules may be destroyed if they are used beyond the absolute maximum ratings.

All voltage values are referenced to VSS = 0V.

4.2 Environmental Condition

Table 4

Item	Operating Temperature (Topr)		Storage Temperature (Tstg)		Remark
	Min.	Max.	Min.	Max.	
Ambient Temperature	0°C	+50°C	-10°C	+60°C	Dry
Humidity	95% max. RH for Ta ≤ 40°C < 95% RH for Ta > 40°C				no condensation
Vibration (IEC 68-2-6) cells must be mounted on a suitable connector	Frequency: 10 ~ 55 Hz Amplitude: 0.75 mm Duration: 20 cycles in each direction.				3 directions
Shock (IEC 68-2-27) Half-sine pulse shape	Pulse duration: 11 ms Peak acceleration: 981 m/s ² = 100g Number of shocks: 3 shocks in 3 mutually perpendicular axes.				3 directions

5. Electrical Specifications

5.1 Typical Electrical Characteristics

At $T_a = 25\text{ }^\circ\text{C}$, $V_{DD} = 5\text{V} \pm 5\%$, $V_{SS} = 0\text{V}$.

Table 5

Parameter	Symbol	Conditions	Min.	Typ.	Max.	Unit
Supply voltage (Logic)	VDD-VSS		4.75	5.0	5.25	V
Supply voltage (LCD)	V _{LCD} =VDD-V ₀	VDD = 5.0V, Note (1) & Note (2).	4.2	4.5	4.8	V
Input signal voltage for E,DB0-DB7,R/W,RS.	V _{IH}	“H” level	2.2	-	VDD	V
	V _{IL}	“L” level	-0.3	-	0.6	V
Supply Current (Logic & LCD)	IDD	Character mode, Note 1	-	1.7	2.6	mA
		Checker board mode, Note 1	-	1.8	2.7	mA
Supply Current (LCD)	I ₀	Character mode, Note 1	-	0.9	1.4	mA
		Checker board mode, Note 1	-	0.9	1.4	mA
Supply voltage of yellow-green LED04 backlight	VLED	Forward current = 315 mA Number of LED dies = 21x2=42	3.9	4.1	4.3	V

Note (1): There is tolerance in optimum LCD driving voltage during production and it will be within the specified range.

5.2 Timing Specifications

At $T_a = 0\text{ }^{\circ}\text{C}$ To $+50\text{ }^{\circ}\text{C}$, $V_{DD} = +5\text{V} \pm 5\%$, $V_{SS} = 0\text{V}$.

Refer to Fig. 2, the bus timing diagram for write mode.

Table 6

Parameter	Symbol	Min.	Max.	Unit	Test pin
E cycle time	t_C	500	-	ns	E
E rise time	t_R	-	25	ns	E
E fall time	t_F	-	25	ns	E
E pulse width (High, Low)	t_W	220	-	ns	E
R/W and RS set-up time	t_{SU1}	40	-	ns	R/W,RS
R/W and RS hold time	t_{H1}	10	-	ns	R/W, RS
Data set-up time	t_{SU2}	60	-	ns	DB0-DB7
Data hold time	t_{H2}	10	-	ns	DB0-DB7

Refer to Fig. 3, the bus timing diagram for read mode .

Table 7

Parameter	Symbol	Min.	Max.	Unit	Test pin
E cycle time	t_C	500	-	ns	E
E rise time	t_R	-	25	ns	E
E fall time	t_F	-	25	ns	E
E pulse width	t_W	220	-	ns	E
R/W and RS set-up time	t_{SU}	40	-	ns	R/W,RS
R/W and RS hold time	t_H	10	-	ns	R/W, RS
Data output delay time	t_D	-	120	ns	DB0-DB7
Data hold time	t_{DH}	20	-	ns	DB0-DB7

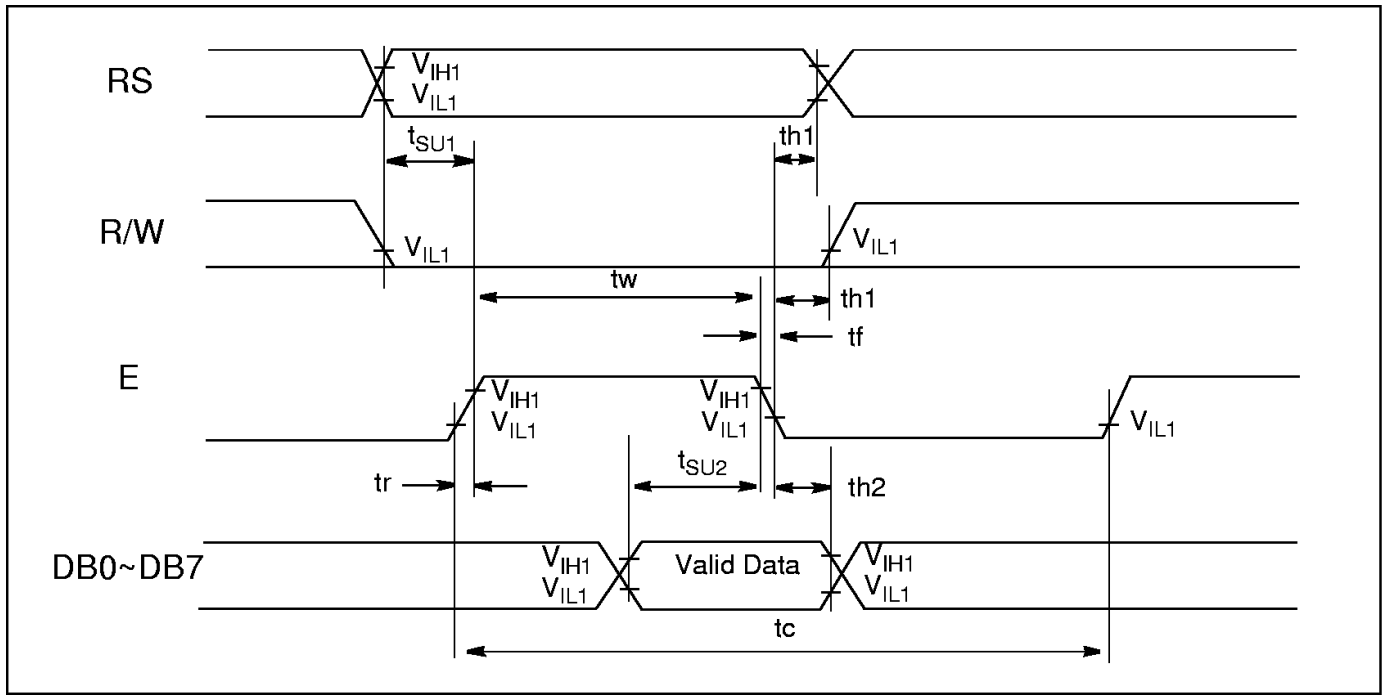

Figure 2: The bus timing diagram for write mode .

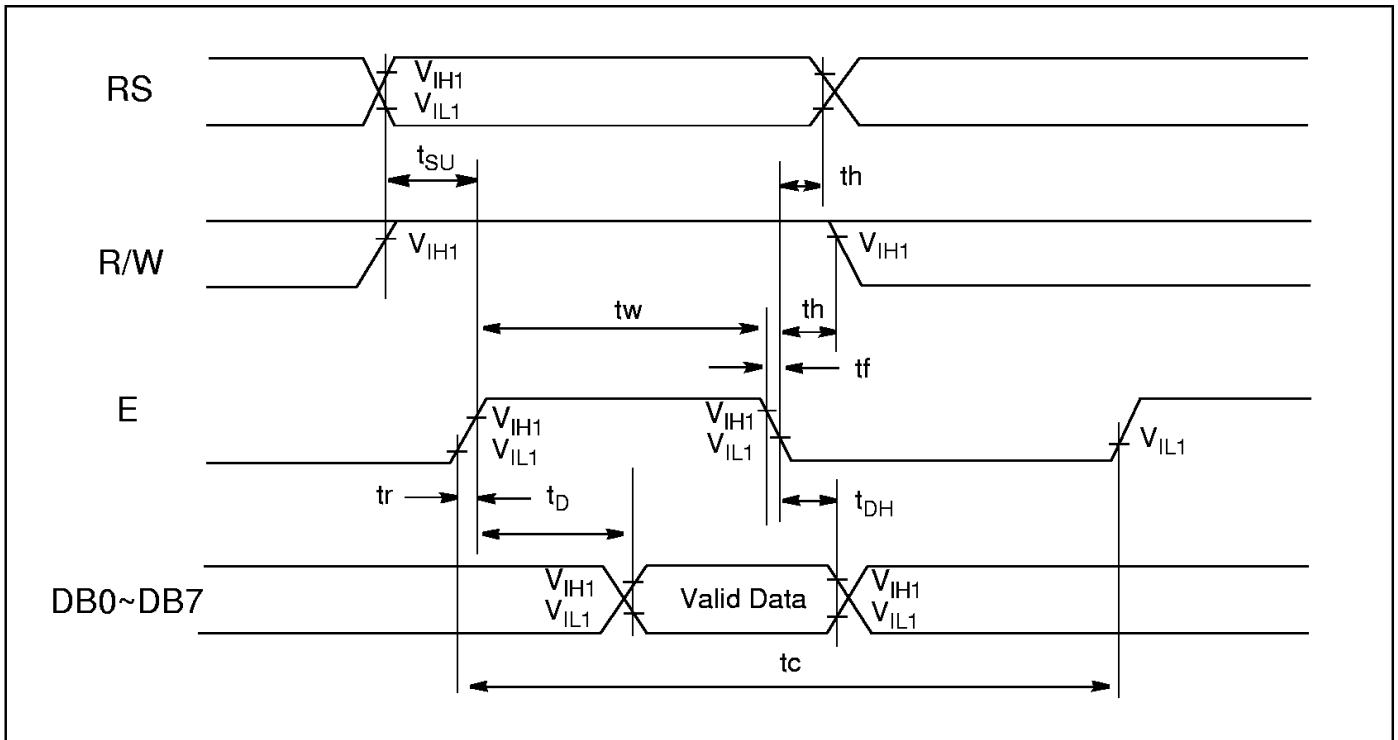

Figure 3: The bus timing diagram for read mode .

5.3 Timing Diagram of VDD against V0.

Power on sequence shall meet the requirement of Figure 4, the timing diagram of VDD against V0.

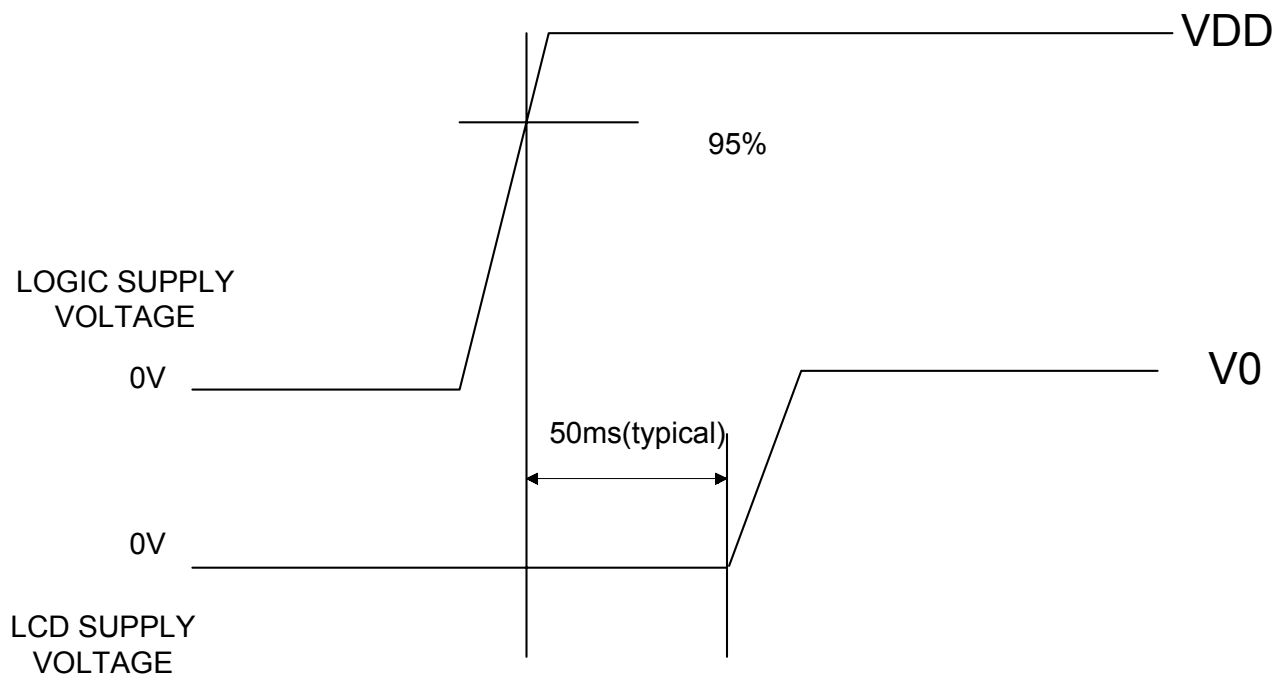

Figure 4: Timing diagram of VDD against V0.

6. CGROM Character Code Table

KS0070B-00															
Upper 4bit / Lower 4bit	LLLL	LLHL	LLHH	LHLL	LHLH	LHHL	LHHH	HLLL	HLLH	HLHL	HLHH	HLLL	HRLH	HHHL	HHHH
LLLL	CG RAM (1)														
LLLH	(2)														
LLHL	(3)														
LLHH	(4)														
LHLL	(5)														
LHLH	(6)														
LHHL	(7)														
LHHH	(8)														
HLLL	(1)														
HLLH	(2)														
HLHL	(3)														
HLHH	(4)														
HLLL	(5)														
HHLH	(6)														
HHHL	(7)														
HHHH	(8)														