

REVISIONS					
REV	ECO	DESCRIPTION	DATE	BY	APPR
A1	-	RELEASED DRAWING	SEP-21-20	BLINK	TOMMY

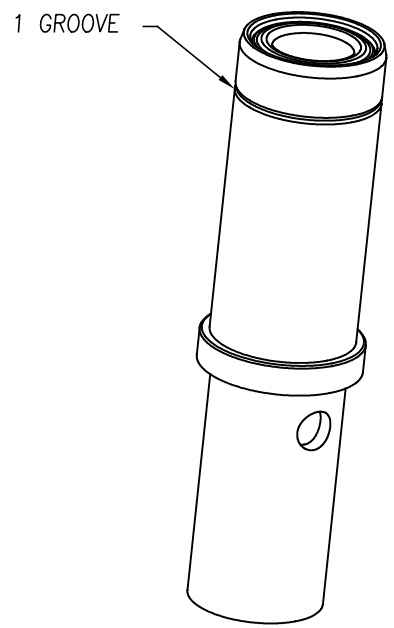
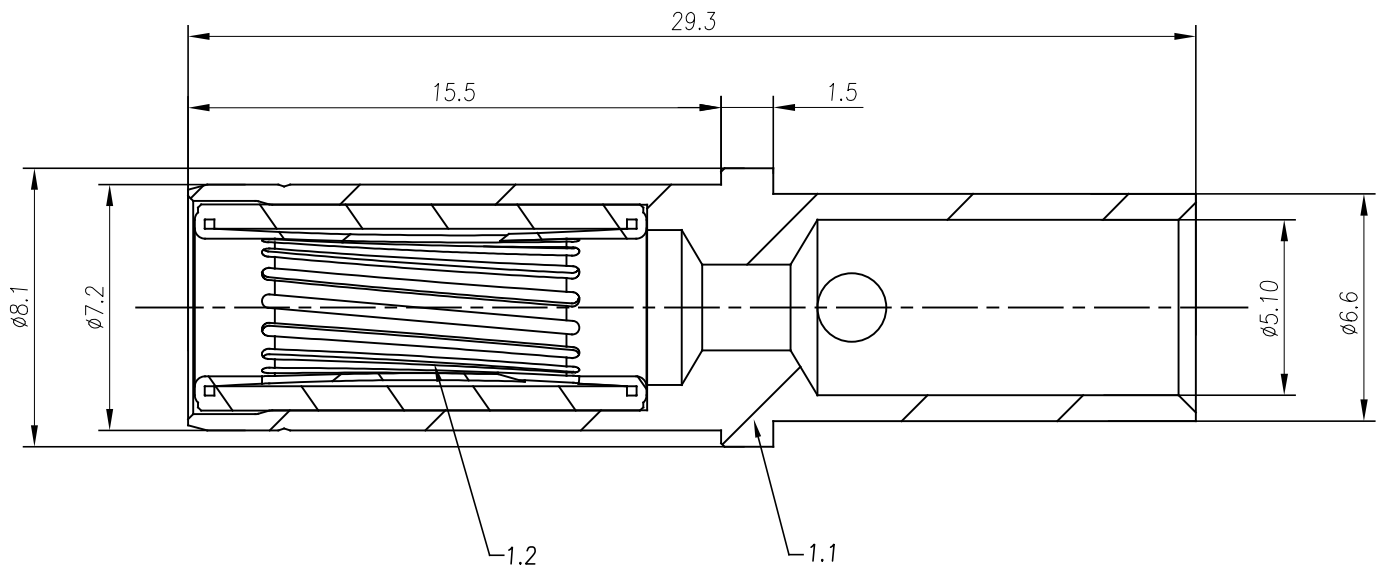

- NOTES: (UNLESS OTHERWISE SPECIFIED)
- MATERIAL:
 - CONTACT BODY: COPPER ALLOY, SILVER PLATED.
 - RADSOK: COPPER ALLOY, SILVER PLATED.
 - SPECIFICATIONS:
 - CURRENT RATING: 70A(MAX).
 - TERMINATION TYPE: CRIMPING.
 - WIRE RANGE: 6-8AWG.
 - SUITABLE SOCKET TYPE: SC000530&SC000531-8
 - RoHS COMPLIANT.
 - ALL DIMENSIONS ARE FOR REFERENCE USE ONLY.

QUANTITY	PART NUMBER	DESCRIPTION	ITEM
MATERIALS LIST			
UNLESS OTHERWISE SPECIFIED 1) All dimensions are in metric(mm). 2) Tolerances are as follows: 1 PL DEC ±0.30 1 Fractions ±1/64 2 PL DEC ±0.15 Angles ±1° 3 PL DEC ±0.08		SIGNATURES DATE DRAWN: BLINK SEP-21-20 CHECKED: ORION SEP-23-20 ENGINEER: APPROVAL: TOMMY SEP-25-20	
MATERIAL SPECIFICATIONS:		CUSTOMER:	
PROCESS SPECIFICATIONS:		THIS DRAWING IS SUPPLIED FOR INFORMATION ONLY. DESIGN FEATURES, SPECIFICATIONS AND PERFORMANCE DATA SHOWN HEREON ARE THE PROPERTY OF THE AMPHENOL CORPORATION. NO RIGHTS OF REPRODUCTION ARE IMPLIED. ALL DIMENSIONS ARE SUBJECT TO NORMAL MANUFACTURING VARIATIONS.	
NEXT ASSY:		SCALE: NONE	
		<div style="text-align: center;"> <p>Sine Systems - www.amphenol-sine.com 44724 Morley Drive Clinton Township, MI 48036</p> </div>	
		SIZE: B TYPE: C- DWG NO: SC000532-6-R4	REVISION: A1 SHEET 1 OF 1

TITLE: 4MM FEMALE SOCKET 6-8AWG
 DWG NO: SC000532-6
 REV: A1
 SH: 1
 OF: 1