



**MICROCHIP**

---

**SAMA5D3  
Ethernet Development System  
User's Guide**

---

---

**Note the following details of the code protection feature on Microchip devices:**

- Microchip products meet the specification contained in their particular Microchip Data Sheet.
- Microchip believes that its family of products is one of the most secure families of its kind on the market today, when used in the intended manner and under normal conditions.
- There are dishonest and possibly illegal methods used to breach the code protection feature. All of these methods, to our knowledge, require using the Microchip products in a manner outside the operating specifications contained in Microchip's Data Sheets. Most likely, the person doing so is engaged in theft of intellectual property.
- Microchip is willing to work with the customer who is concerned about the integrity of their code.
- Neither Microchip nor any other semiconductor manufacturer can guarantee the security of their code. Code protection does not mean that we are guaranteeing the product as "unbreakable."

Code protection is constantly evolving. We at Microchip are committed to continuously improving the code protection features of our products. Attempts to break Microchip's code protection feature may be a violation of the Digital Millennium Copyright Act. If such acts allow unauthorized access to your software or other copyrighted work, you may have a right to sue for relief under that Act.

---

Information contained in this publication regarding device applications and the like is provided only for your convenience and may be superseded by updates. It is your responsibility to ensure that your application meets with your specifications. MICROCHIP MAKES NO REPRESENTATIONS OR WARRANTIES OF ANY KIND WHETHER EXPRESS OR IMPLIED, WRITTEN OR ORAL, STATUTORY OR OTHERWISE, RELATED TO THE INFORMATION, INCLUDING BUT NOT LIMITED TO ITS CONDITION, QUALITY, PERFORMANCE, MERCHANTABILITY OR FITNESS FOR PURPOSE. Microchip disclaims all liability arising from this information and its use. Use of Microchip devices in life support and/or safety applications is entirely at the buyer's risk, and the buyer agrees to defend, indemnify and hold harmless Microchip from any and all damages, claims, suits, or expenses resulting from such use. No licenses are conveyed, implicitly or otherwise, under any Microchip intellectual property rights unless otherwise stated.

**Trademarks**

The Microchip name and logo, the Microchip logo, AnyRate, AVR, AVR logo, AVR Freaks, BitCloud, chipKIT, chipKIT logo, CryptoMemory, CryptoRF, dsPIC, FlashFlex, flexPWR, Heldo, JukeBlox, KeeLoq, Kleer, LANCheck, LINK MD, maXStylus, maXTouch, MediaLB, megaAVR, MOST, MOST logo, MPLAB, OptoLyzer, PIC, picoPower, PICSTART, PIC32 logo, Prochip Designer, QTouch, SAM-BA, SpyNIC, SST, SST Logo, SuperFlash, tinyAVR, UNI/O, and XMEGA are registered trademarks of Microchip Technology Incorporated in the U.S.A. and other countries.

ClockWorks, The Embedded Control Solutions Company, EtherSynch, Hyper Speed Control, HyperLight Load, IntelliMOS, mTouch, Precision Edge, and Quiet-Wire are registered trademarks of Microchip Technology Incorporated in the U.S.A.

Adjacent Key Suppression, AKS, Analog-for-the-Digital Age, Any Capacitor, AnyIn, AnyOut, BodyCom, CodeGuard, CryptoAuthentication, CryptoAutomotive, CryptoCompanion, CryptoController, dsPICDEM, dsPICDEM.net, Dynamic Average Matching, DAM, ECAN, EtherGREEN, In-Circuit Serial Programming, ICSP, INICnet, Inter-Chip Connectivity, JitterBlocker, KleerNet, KleerNet logo, memBrain, Mindi, MiWi, motorBench, MPASM, MPF, MPLAB Certified logo, MPLIB, MPLINK, MultiTRAK, NetDetach, Omniscient Code Generation, PICDEM, PICDEM.net, PICKit, PICtail, PowerSmart, PureSilicon, QMatrix, REAL ICE, Ripple Blocker, SAM-ICE, Serial Quad I/O, SMART-I.S., SQI, SuperSwitcher, SuperSwitcher II, Total Endurance, TSHARC, USBCheck, VariSense, ViewSpan, WiperLock, Wireless DNA, and ZENA are trademarks of Microchip Technology Incorporated in the U.S.A. and other countries.

SQTP is a service mark of Microchip Technology Incorporated in the U.S.A.

Silicon Storage Technology is a registered trademark of Microchip Technology Inc. in other countries.

GestIC is a registered trademark of Microchip Technology Germany II GmbH & Co. KG, a subsidiary of Microchip Technology Inc., in other countries.

All other trademarks mentioned herein are property of their respective companies.

© 2018, Microchip Technology Incorporated, All Rights Reserved.

ISBN: 978-1-5224-3368-2

**QUALITY MANAGEMENT SYSTEM**  
**CERTIFIED BY DNV**  
**== ISO/TS 16949 ==**

*Microchip received ISO/TS-16949:2009 certification for its worldwide headquarters, design and wafer fabrication facilities in Chandler and Tempe, Arizona; Gresham, Oregon and design centers in California and India. The Company's quality system processes and procedures are for its PIC<sup>®</sup> MCUs and dsPIC<sup>®</sup> DSCs, KEELoq<sup>®</sup> code hopping devices, Serial EEPROMs, microperipherals, nonvolatile memory and analog products. In addition, Microchip's quality system for the design and manufacture of development systems is ISO 9001:2000 certified.*

**Table of Contents**

<b>Preface</b> .....	<b>5</b>
Introduction.....	5
Document Layout .....	5
Conventions Used in this Guide .....	7
The Microchip Website .....	8
Development Systems Customer Change Notification Service .....	8
Customer Support .....	8
Document Revision History .....	9
<b>Chapter 1. Overview</b>	
1.1 Introduction .....	11
1.2 References .....	12
1.3 Software and Programming Resources .....	12
<b>Chapter 2. Getting Started</b>	
2.1 Introduction .....	13
2.2 SAMA5D3 EDS and EVB-KSZ9563 Configuration .....	13
<b>Chapter 3. Board Details and Configuration</b>	
3.1 Introduction .....	15
3.2 Power Source .....	15
3.3 Processor and Memory .....	15
3.4 Flash Memory Programming .....	16
3.5 Reset .....	16
3.6 RGMII/MII GMAC Connector .....	17
3.7 RMII EMAC Connector .....	18
3.8 USB Ports .....	19
3.9 Serial UART Interface .....	19
3.10 JTAG Port .....	19
3.11 Board Features and Specifications .....	19
<b>Chapter 4. Software Configuration and Operation</b>	
4.1 Introduction .....	21
4.2 Communication Options .....	21
4.2.1 Ethernet Communication Option – Telnet .....	21
4.2.2 USB-to-Serial Communication Option .....	22
4.3 Software Version .....	23
4.4 IP and MAC Addresses .....	24
4.5 Ethernet Device Register Address .....	24
4.6 Ethernet Switch MIB Counters .....	24

# SAMA5D3 Ethernet Development System User's Guide

---

4.7 Bootloader Settings .....	25
4.8 Automatically Running Process .....	25
4.9 Precision Time Protocol (IEEE 1588) .....	26
4.10 VLAN Setup .....	26
4.11 DHCP .....	26
4.12 Nuttcp Traffic Testing .....	26
<b>Appendix A. Programming the SAMA5D3 EDS Board</b>	
A.1 Introduction .....	27
A.2 NAND Flash Programming .....	27
A.2.1 NAND Flash Programming on Linux .....	27
A.2.2 NAND Flash Programming on Windows .....	27
A.3 SD Card Image Programming .....	32
A.3.1 SD Card Programming .....	32
A.4 Booting the SAMA5D3 EDS .....	33
A.4.1 Booting from NAND Flash .....	33
A.4.2 Booting from SD Card .....	33
<b>Appendix B. Schematics</b>	
B.1 Introduction .....	35
<b>Appendix C. Bill of Materials</b>	
C.1 Introduction .....	43
<b>Worldwide Sales and Service .....</b>	<b>48</b>

---

---

## Preface

---

---

### NOTICE TO CUSTOMERS

All documentation becomes dated, and this manual is no exception. Microchip tools and documentation are constantly evolving to meet customer needs, so some actual dialogs and/or tool descriptions may differ from those in this document. Please refer to our website ([www.microchip.com](http://www.microchip.com)) to obtain the latest documentation available.

Documents are identified with a “DS” number. This number is located on the bottom of each page, in front of the page number. The numbering convention for the DS number is “DSXXXXA”, where “XXXX” is the document number and “A” is the revision level of the document.

For the most up-to-date information on development tools, see the MPLAB® IDE online help. Select the Help menu, and then Topics to open a list of available online help files.

## INTRODUCTION

This chapter contains general information that will be useful to know before using the SAMA5D3. Items discussed in this chapter include:

- [Document Layout](#)
- [Conventions Used in this Guide](#)
- [The Microchip Website](#)
- [Development Systems Customer Change Notification Service](#)
- [Customer Support](#)
- [Document Revision History](#)

## DOCUMENT LAYOUT

This document describes the Microchip SAMA5D3 Ethernet Development System Board.

- **Chapter 1. “Overview”** – This chapter provides a brief description of the SAMA5D3 Ethernet Development System Board.
- **Chapter 2. “Getting Started”** – This chapter includes instructions on how to get started with the SAMA5D3 Ethernet Development System Board.
- **Chapter 3. “Board Details and Configuration”** – This chapter includes instructions on how to configure the SAMA5D3 Ethernet Development System Board to work with the EVB-KSZ9563 3-port switch evaluation board.
- **Chapter 4. “Software Configuration and Operation”** – This chapter explains how to establish a communication channel from a PC to the SAMA5D36 MPU. It also provides some examples of things to do in the bootloader and Linux environments once connected.
- **Appendix A. “Programming the SAMA5D3 EDS Board”** – This appendix includes instructions on how to program the SAMA5D3 EDS on-board NAND flash and how to prepare a bootable SD card.

## SAMA5D3 Ethernet Development System User's Guide

---

- **Appendix B. "Schematics"** – This appendix shows the SAMA5D3 Ethernet Development System Board schematics.
- **Appendix C. "Bill of Materials"** – This appendix includes the SAMA5D3 Ethernet Development System Board Bill of Materials (BOM).

## CONVENTIONS USED IN THIS GUIDE

This manual uses the following documentation conventions:

### DOCUMENTATION CONVENTIONS

Description	Represents	Examples
<b>Arial font:</b>		
Italic characters	Referenced books	<i>MPLAB<sup>®</sup> IDE User's Guide</i>
	Emphasized text	...is the <i>only</i> compiler...
Initial caps	A window	the Output window
	A dialog	the Settings dialog
	A menu selection	select Enable Programmer
Quotes	A field name in a window or dialog	"Save project before build"
Underlined, italic text with right angle bracket	A menu path	<u><i>File</i></u> >Save
Bold characters	A dialog button	Click <b>OK</b>
	A tab	Click the <b>Power</b> tab
N'Rnnnn	A number in verilog format, where N is the total number of digits, R is the radix and n is a digit.	4'b0010, 2'hF1
Text in angle brackets < >	A key on the keyboard	Press <Enter>, <F1>
<b>Courier New font:</b>		
Plain Courier New	Sample source code	#define START
	Filenames	autoexec.bat
	File paths	c:\mcc18\h
	Keywords	_asm, _endasm, static
	Command-line options	-Opa+, -Opa-
	Bit values	0, 1
	Constants	0xFF, 'A'
Italic Courier New	A variable argument	<i>file.o</i> , where <i>file</i> can be any valid filename
Square brackets [ ]	Optional arguments	mcc18 [options] <i>file</i> [options]
Curly brackets and pipe character: {   }	Choice of mutually exclusive arguments; an OR selection	errorlevel {0 1}
Ellipses...	Replaces repeated text	var_name [, var_name...]
	Represents code supplied by user	void main (void) { ... }

# SAMA5D3 Ethernet Development System User's Guide

---

## THE MICROCHIP WEBSITE

Microchip provides online support via our website at [www.microchip.com](http://www.microchip.com). This website is used as a means to make files and information easily available to customers. Accessible by using your favorite Internet browser, the website contains the following information:

- **Product Support** – Data sheets and errata, application notes and sample programs, design resources, user's guides and hardware support documents, latest software releases, and archived software
- **General Technical Support** – Frequently Asked Questions (FAQs), technical support requests, online discussion groups, Microchip consultant program, and member listing
- **Business of Microchip** – Product selector and ordering guides, latest Microchip press releases, listing of seminars and events, listings of Microchip sales offices, distributors, and factory representatives

## DEVELOPMENT SYSTEMS CUSTOMER CHANGE NOTIFICATION SERVICE

Microchip's customer notification service helps keep customers current on Microchip products. Subscribers will receive e-mail notifications whenever there are changes, updates, revisions, or errata related to a specified product family or development tool of interest.

To register, access the Microchip website at [www.microchip.com](http://www.microchip.com), click on Customer Change Notification and follow the registration instructions.

The Development Systems product group categories are:

- **Compilers** – The latest information on Microchip C compilers, assemblers, linkers and other language tools. These include all MPLAB<sup>®</sup> C compilers; all MPLAB assemblers (including MPASM assembler); all MPLAB linkers (including MPLINK object linker); and all MPLAB librarians (including MPLIB object librarian).
- **Emulators** – The latest information on Microchip in-circuit emulators. This includes the MPLAB REAL ICE and MPLAB ICE 2000 in-circuit emulators.
- **In-Circuit Debuggers** – The latest information on the Microchip in-circuit debuggers. This includes MPLAB ICD 3 in-circuit debuggers and PICKit 3 debug express.
- **MPLAB IDE** – The latest information on Microchip MPLAB IDE, the Windows Integrated Development Environment for development systems tools. This list is focused on the MPLAB IDE, MPLAB IDE Project Manager, MPLAB Editor and MPLAB SIM simulator, as well as general editing and debugging features.
- **Programmers** – The latest information on Microchip programmers. These include production programmers such as MPLAB REAL ICE in-circuit emulator, MPLAB ICD 3 in-circuit debugger and MPLAB PM3 device programmers. Also included are nonproduction development programmers such as PICSTART Plus and PIC-kit 2 and 3.

## CUSTOMER SUPPORT

Users of Microchip products can receive assistance through several channels:

- Distributor or Representative
- Local Sales Office
- Field Application Engineer (FAE)
- Technical Support



Customers should contact their distributor, representative or field application engineer (FAE) for support. Local sales offices are also available to help customers. A listing of sales offices and locations is included in the back of this document.

Technical support is available through the website at:  
<http://www.microchip.com/support>

## DOCUMENT REVISION HISTORY

Revisions	Section/Figure/Entry	Correction
DS50002789A (08-2-18)	Initial release	

# SAMA5D3 Ethernet Development System User's Guide

---

NOTES:

**Chapter 1. Overview**

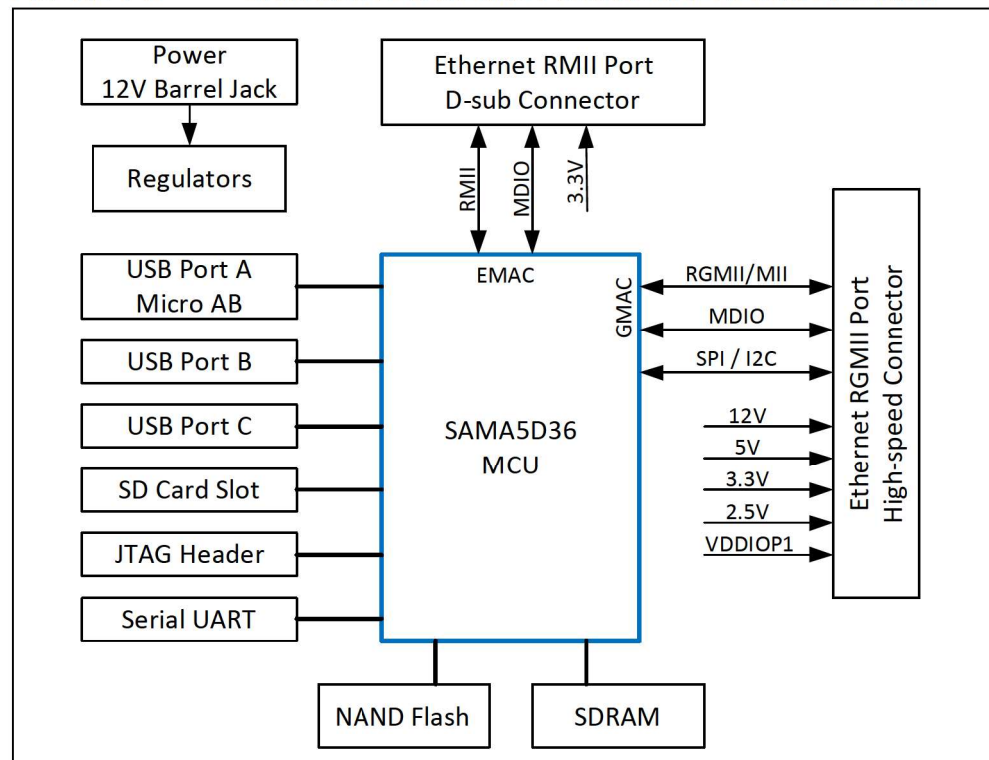
**1.1 INTRODUCTION**

The Microchip SAMA5D3 Ethernet Development System (EDS) Board is an MPU-based platform for evaluating Ethernet switch and PHY products. Compatible switch and PHY evaluation boards connect to the EDS board via either an RGMII connector or an RMII connector. These daughter boards are available separately. The EDS board is not intended for stand-alone use and has no Ethernet capabilities when no daughter board is connected. See [Figure 1-1](#).

The SAMA5D3 EDS board comes with pre-installed Linux and Ethernet drivers. When mated to a switch evaluation board, the included software can run protocols, such as RSTP, DHCP, and PTP (1588). Users can also access registers and statistics counters in the PHY or switch, set up VLAN and other configurations in a switch, and perform traffic testing to/from the MCU. Source code is available for download from the website for this board, and users may modify and append to it for their needs.

This board is built around a Cortex<sup>®</sup>-A5-based processor on-board SDRAM and Flash memory, two Ethernet MACs (one gigabit and one 100 Mbit), three USB ports, an SD card slot, and a Serial UART interface. It is similar to the SAMA5D3 Xplained Evaluation Board (SAMA5D3-XPLD) but with the PHYs removed and replaced by the RMII and RGMII connectors. The two boards share the same development environment.

**FIGURE 1-1: SAMA5D3 EDS BOARD FUNCTIONAL BLOCK DIAGRAM**



# SAMA5D3 Ethernet Development System User's Guide

---

## 1.2 REFERENCES

Concepts and materials available in the following documents may be helpful when reading this document. Visit [www.microchip.com](http://www.microchip.com) for the latest documentation.

- *SAMA5D3 Series Data Sheet*

## 1.3 SOFTWARE AND PROGRAMMING RESOURCES

The following files are available for download from the Microchip website at [www.microchip.com/DevelopmentTools/ProductDetails/PartNo/SAMA5D3+Ethernet+Development+System](http://www.microchip.com/DevelopmentTools/ProductDetails/PartNo/SAMA5D3+Ethernet+Development+System):

- Linux image bit file
- Source code
- Documents:
  - *Ethernet Development System Image Programming Guide*
  - *EVB-KSZ8563/KSZ9563 3-Port Switch Software User's Guide*

---

---

## Chapter 2. Getting Started

---

---

### 2.1 INTRODUCTION

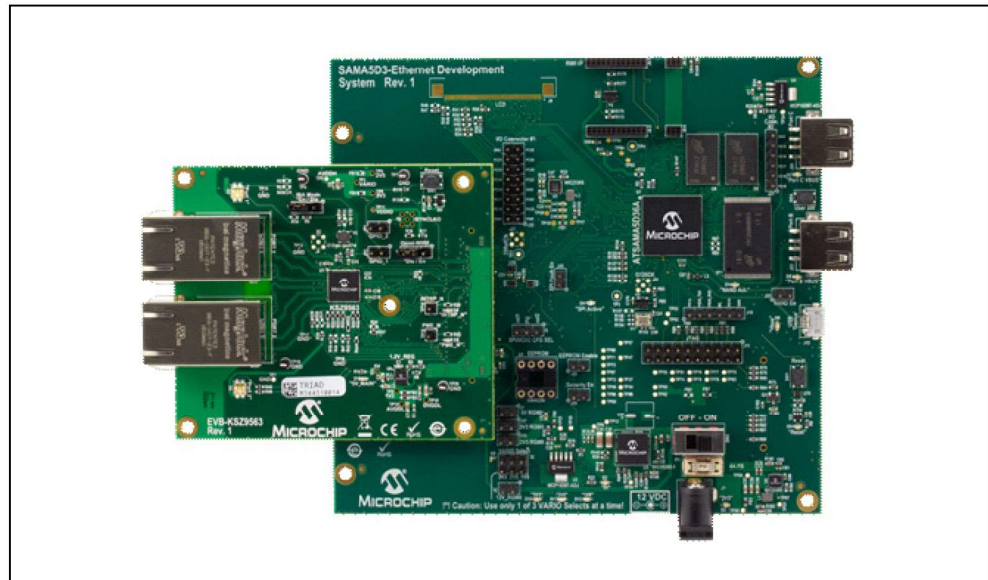
This section outlines the steps to bring up the SAMA5D3 EDS board with a daughter board such as the EVB-KSZ9563 3-port switch evaluation board.

### 2.2 SAMA5D3 EDS AND EVB-KSZ9563 CONFIGURATION

To configure the SAMA5D3 EDS board to work with the EVB-KSZ9563 3-port switch evaluation board:

1. Install the following jumpers:
  - J2 pins 5-6 (select 3V3 for VDDIOP1/VARIO)
  - J20 to enable NAND flash
  - J3, J7, J17, and J13 for 12V, 5V, 3V3 and 2V5, respectively, to the RGMII connector
2. Remove any jumper from J4 to select SPI management. Note that different daughter boards may require a jumper on J4.
3. Check the daughter board documentation for possible configuration settings on that board.
4. Connect the daughter board to the SAMA5D3 EDS board as shown in [Figure 2-1](#).

**FIGURE 2-1: SAMA5D3 EDS CONNECTED TO THE EVB-KSZ9563**



## SAMA5D3 Ethernet Development System User's Guide

---

5. Connect a 12V power adapter to the SAMA5D3 EDS board. When the board is powered on, it boots the installed Linux operating system.
6. The default IP address for the MPU is 192.168.0.210. Functionality of the Ethernet daughter board can be verified by connecting a PC to an Ethernet port on the daughter board and pinging the MPU. (Ensure that the PC is set up with a compatible IP address in the same subnet.)
7. Follow the instructions in [Section 4.2 “Communication Options”](#) to communicate with the MPU from a PC.

---

---

## Chapter 3. Board Details and Configuration

---

---

### 3.1 INTRODUCTION

The SAMA5D3 EDS board is designed to connect to compatible Microchip Ethernet switch and PHY evaluation boards. The board is built around the integration of a Cortex<sup>®</sup>-A5-based microcontroller with external SDRAM and Flash memory, dual Ethernet ports, two host USB ports, and one device USB port, an SD interface, and a serial debug interface. It comes programmed with Linux, Ethernet drivers, and protocol stacks for switch and PHY evaluation.

### 3.2 POWER SOURCE

Power is supplied to the board via a power jack. The nominal supply voltage is 12V, and the acceptable range is 7V to 20V. The current requirement is less than 500 mA without external loads. The barrel connector has an inner diameter of 2.5 mm.

This board can supply power to the other boards connected to the RGMII connector J5 and to the RMII connector J6.

Green power LEDs D2 and D3 indicate 3.3V and 5V power, respectively.

The board cannot be powered via USB.

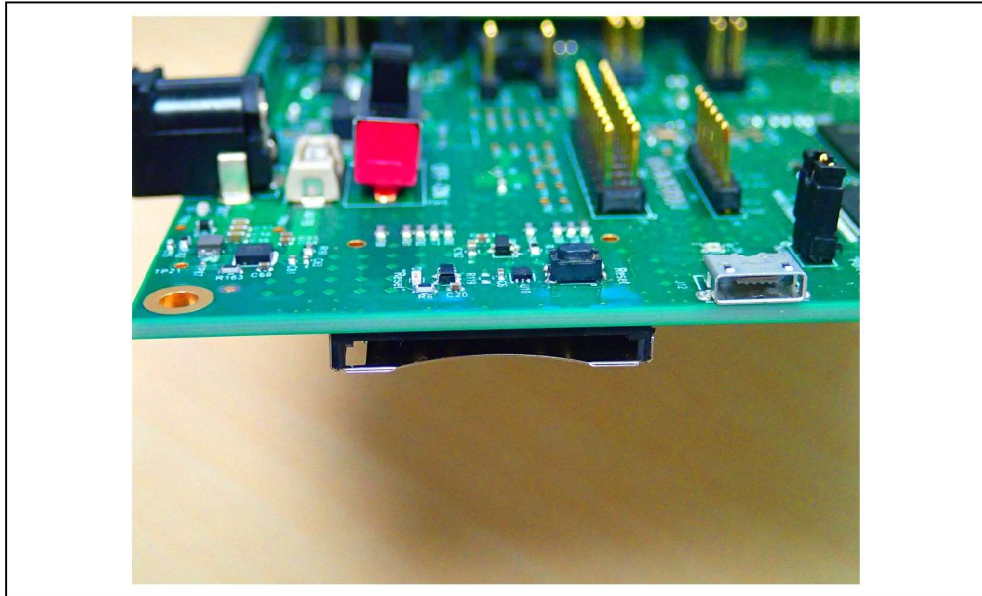
### 3.3 PROCESSOR AND MEMORY

The board has 256 MB of SDRAM and 256 MB of NAND flash. As shown in [Figure 3-1](#), a card slot at the bottom of the board accepts an SD card. The processor can boot either from the on-board NAND flash or from an SD card.

When booting, the SD card takes precedence. If there is no SD card, the processor attempts to boot from the on-board flash. The J20 jumper must be installed to enable writing and reading the on-board flash memory.

**Note:** The voltage selection on the J2 jumper controls the voltage for the SD card interface. Set J2 for 3V3 whenever using an SD card.

FIGURE 3-1: SD CARD SLOT ON THE BOTTOM OF THE BOARD



### 3.4 FLASH MEMORY PROGRAMMING

The board is preprogrammed with a Linux image that includes an Ethernet driver and evaluation code. Users may reprogram the on-board flash memory via the micro-AB USB port (USB port A). The latest Linux image can be found in the product page of the board on the Microchip website. For on-board flash memory and SD card programming instructions, refer to [Appendix A. "Programming the SAMA5D3 EDS Board"](#). The J20 jumper must be installed to enable the on-board flash memory for programming. However, when reprogramming an already programmed board, it may be necessary to follow these steps:

1. Remove the J20 jumper (this prevents the MCU from booting from the on-board flash memory).
2. Power on the board
3. Install the J20 jumper (This enables the flash memory for programming.)
4. Program the on-board flash memory.

### 3.5 RESET

The SW1 push button can be used to reset the MCU.

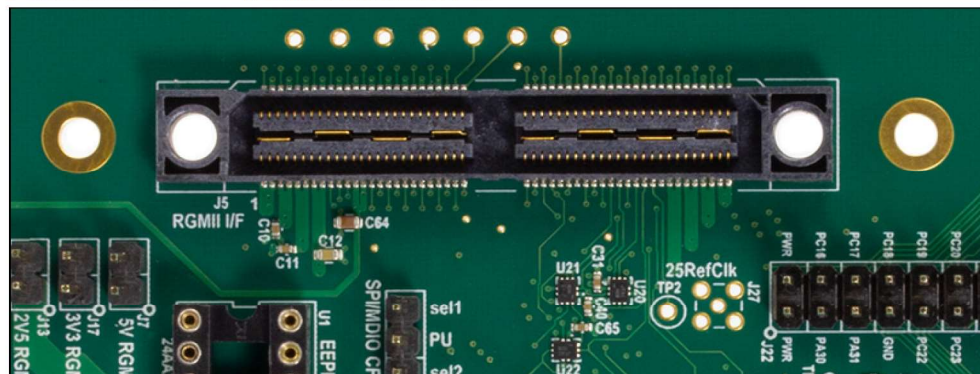


# Board Details and Configuration

## 3.6 RGMII/MII GMAC CONNECTOR

This connector allows a daughter board to be connected to the GMAC port of the SAMA5D3. (See [Figure 3-2](#).) The daughter board is a Microchip evaluation board for an Ethernet PHY or an Ethernet switch. This interface is used primarily for RGMII, and the supplied software operates it as RGMII. This GMAC can also operate as MII, but this is a secondary option that is not necessarily supported by the pre-installed software. Daughter boards may support only RGMII, only MII, or both RGMII and MII, so check the daughter board documentation for details.

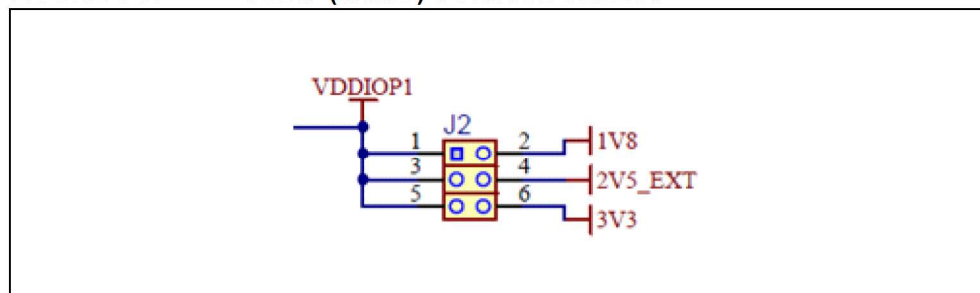
**FIGURE 3-2: RGMII CONNECTOR**



A daughter board receives power from the SAMA5D3 EDS board via any of the available supplies: VDDIOP1 (VARIO), 2V5, 3V3, 5V, or 12V. The daughter board documentation specifies which power rail(s) are used. Jumpers J3, J7, J13, and J17 are used to connect/disconnect 12V, 5V, 3V3, and 2V5 to this connector. Normally, all of these jumpers should be installed even if some voltages are not needed by the daughter board.

Header J2 is used to select the voltage for VDDIOP1: either 3.3V, 2.5V, or 1.8V. (Refer to [Figure 3-3](#).) Except for the two I<sup>2</sup>C signals, all the signals on this connector operate at I/O voltage VDDIOP1. The I<sup>2</sup>C signals operate at 3.3V, independent of VDDIOP1. The VDDIOP1 must be set at 3.3V whenever the SD card or the I<sup>2</sup>C is used. Daughter boards may or may not use VDDIOP1 supplied from the SAMA5D3 board. All daughter boards are compatible with VDDIOP1 = 3.3V, but not necessarily with 2.5V or 1.8V. Check the daughter board documentation for I/O voltage compatibility and possible configuration details.

**FIGURE 3-3: VDDIP (VARIO) VOLTAGE SELECT**



Three indicator LEDs make it easy to visually verify the VDDIOP1 (VARIO) voltage:

- D10: Green = 3.3V
- D11: Yellow = 2.5V
- D12: Blue = 1.8V

# SAMA5D3 Ethernet Development System User's Guide

---

The MPU requires a 125 MHz reference clock input for its GMAC interface. This is provided by on-board oscillator Y3. This clock does not need to be supplied by the daughter board.

Three management interface options are available across the RGMII connector: SPI, I<sup>2</sup>C, and MDIO/MDC. Check the daughter board documentation to determine which option(s) it supports, then ensure that both boards are configured for the same management interface.

On the SAMA5D3 EDS board, the management interface type is selected by jumper options on Header J4. [Table 3-1](#) shows the jumper settings for each interface option.

**TABLE 3-1: MANAGEMENT INTERFACE SELECTION HEADER J4**

Header J4	Board Mode	Management I/F
Jumper pins 2-3	SEL1	I2C
Jumper pins 1-2	SEL2	
Open	SEL3	SPI

If the daughter board uses both SPI and MDIO at the same time (which is uncommon), then use header J4 to select MDIO. SPI would use other non-muxed pins on the RGMII connector.

Additional signals on the RGMII connector:

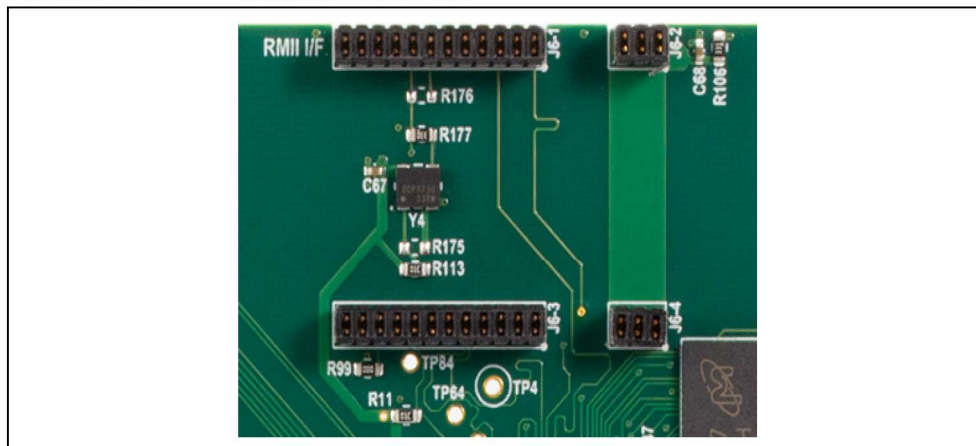
- **Reset.** The SAMA5D3 EDS board combines both hardware and software generated reset signals into one reset signal that is available to the daughter board. The daughter board may or may not use this reset signal. The hardware reset is generated at power-on, and can also be generated by pressing the push-button SW1. The SAMA5D3 can also generate a reset from software via GPIO pin PD19.
- **Interrupt (IRQ\_N).** This is an input to the MPU from the daughter board. It goes to MPU I/O pin PB28.
- **PME input from the daughter board.** It connects to MPU I/O pin PD17, but the standard software release may not utilize it.
- **SAMA5D3 GPIO pins PD14, PD15, and PD16** are also wired to the RGMII connector and are available for general use.

## 3.7 RMII EMAC CONNECTOR

J6 is a four-piece, 30-pin connector for connecting an Ethernet daughter board to the MPU's EMAC interface via RMII. The SAMA5D3 EDS board supplies 3.3V power to the daughter board. An on-board 50 MHz oscillator provides the RMII REFCLK to both the MPU and the RMII connector for the daughter board. Separate SPI and MDIO interfaces at the connector allow the MPU to manage the daughter board device. The MPU uses Serial Peripheral Interface 1 (SPI1) with NPC3 for SPI and the EMAC MDC/MDIO for MDC/MDIO. See [Figure 3-4](#).

# Board Details and Configuration

FIGURE 3-4: RMII CONNECTOR



## 3.8 USB PORTS

The SAMA5D3 EDS board features three USB ports:

- Port A: High-speed and full-speed host multiplexed with high-speed USB device, micro-AB connector J12
- Port B: High-speed and full-speed host, standard Type A connector J23
- Port C: Full-speed host, standard Type A connector J24

## 3.9 SERIAL UART INTERFACE

Serial I/O communication to the MPU is available on 1x6 pin header J10. Only the RX, TX, and GND pins are used. The other pins are either not connected or can be ignored. The default serial port settings are 115200 baud, 8 bits, no parity, and 1 Stop bit (8N1). This is a 3.3V interface. See [Section 4.2.2 “USB-to-Serial Communication Option”](#) for more details on using this connector.

## 3.10 JTAG PORT

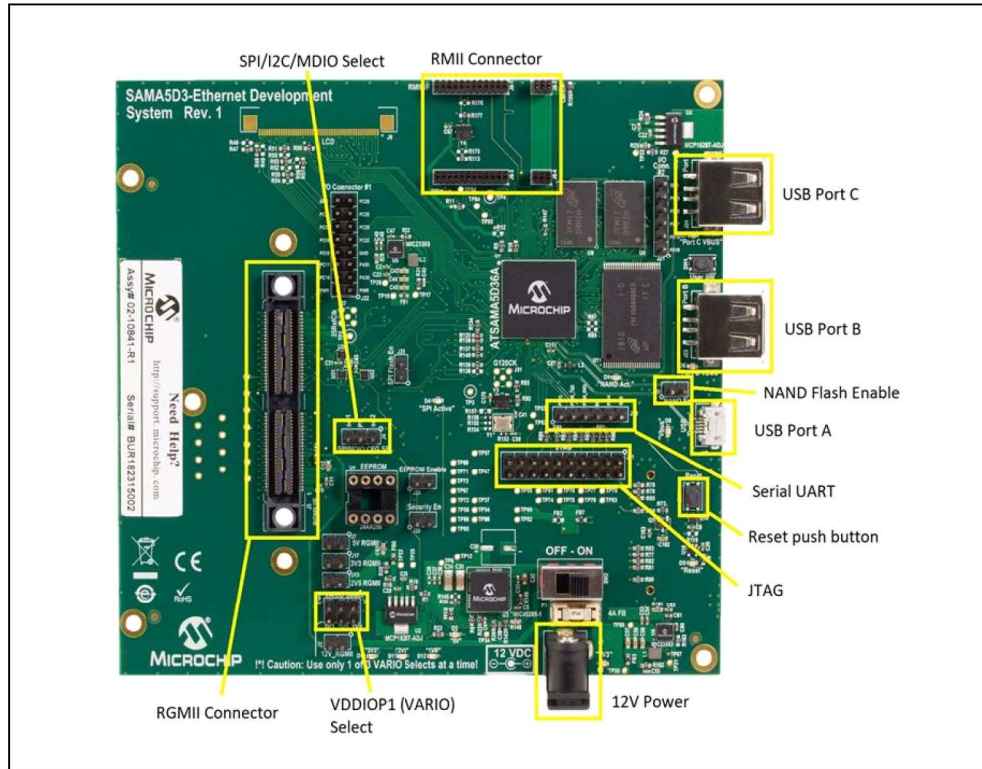
A standard 2 x 10-pin JTAG header (J11) is implemented on the board to enable software development and debugging of the board using various JTAG emulators. The interface signals have a voltage level of 3.3V.

## 3.11 BOARD FEATURES AND SPECIFICATIONS

[Figure 3-5](#) shows the top view of the SAMA5D3 EDS board with its key features, and [Table 3-2](#) details the specifications of the SAMA5D3 EDS board.

# SAMA5D3 Ethernet Development System User's Guide

**FIGURE 3-5: SAMA5D3 EDS BOARD'S MAIN FEATURES**



**TABLE 3-2: SAMA5D3 EDS BOARD SPECIFICATIONS**

Characteristics	Specifications
Processor	SAMA5D36 (324-ball BGA package) ARM <sup>®</sup> Cortex-A5 Processor with v7-A Thumb <sup>®</sup> -2 instruction set, core frequency up to 536 MHz
Memory	2 x 1 Gb DDR2 (16M x 16 bits x 8 banks) 1 x 2 Gb NAND flash (256M x 8 bits)
Optional on-board memory	One I <sup>2</sup> C EEPROM One SPI Serial Flash
SD	One 8-bit SD card slot
USB	Two USB Hosts One micro-AB USB device
Ethernet	One 1 Gb MAC with RGMII interface One 10/100 Mb MAC with RMIII interface
Debug port	One JTAG interface connector One serial debug interface (3.3V level)
Board supply voltage	12V power jack
User interface	Reset push button LEDs for power, reset, USB, and NAND flash disable
Expansion	One 8 x 2 GPIO header with two-wire, SPI, and audio One 1 x 6 GPIO header with USART

---

---

## Chapter 4. Software Configuration and Operation

---

---

### 4.1 INTRODUCTION

The SAMA5D3 EDS board is pre-configured with Linux and Ethernet drivers. This includes some command line utilities for controlling certain switch functions. In addition, the user can interact with the driver to monitor and control the attached switch daughter board.

This chapter explains how to establish a communication channel from a PC to the SAMA5D36 MPU and gives some examples of things to do in the bootloader and Linux environments once connected. Additional documentation on the software capabilities and usage for this board is available on the Microchip website at [www.microchip.com](http://www.microchip.com).

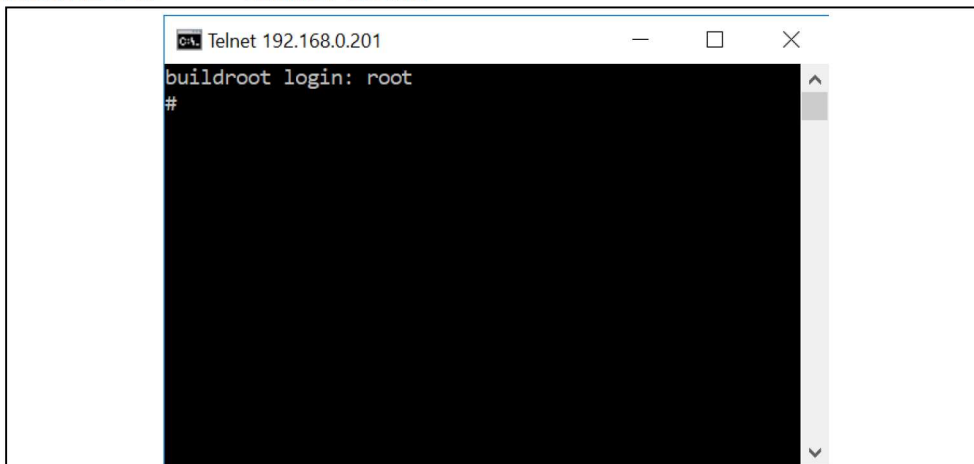
### 4.2 COMMUNICATION OPTIONS

There are two ways to establish a communication interface from a PC to the MPU: either via Ethernet or via USB-to-serial.

#### 4.2.1 Ethernet Communication Option – Telnet

1. Connect a compatible Ethernet daughter board to either the RGMII or RMII connector and ensure that all jumper settings are correct on both boards.
2. Connect an Ethernet cable between the daughter board and a PC.
3. Set the network port IP address on the PC to 192.168.0.100 and set the subnet mask to 255.255.255.0.
4. From a command prompt window on the PC, enter the following command: ping 192.168.0.210
  - a) If ping doesn't work, there may be a problem with the RGMII/RMII or SPI/I2C/MDIO interfaces between the boards, with the PC network settings, or with the IP address on the SMA5D3 EDS board. If the problem cannot be readily resolved, try the USB-to-Serial option instead.
5. From the same command window on the PC, enter the following command: telnet 192.168.0.210
  - a) It may be necessary to enable Telnet on a Windows PC by going to *Control Panel > Programs and Features > Turn Windows Features On or Off* and then check the box for Telnet Client.
  - b) Alternatively, many communication programs such as PuTTY and TeraTerm can be used to open a Telnet session.
6. The command prompt window should change to Telnet and should display a login prompt for Linux. The login is "root" (no quotes). No password is required. See [Figure 4-1](#).

FIGURE 4-1: TELNET LOGIN



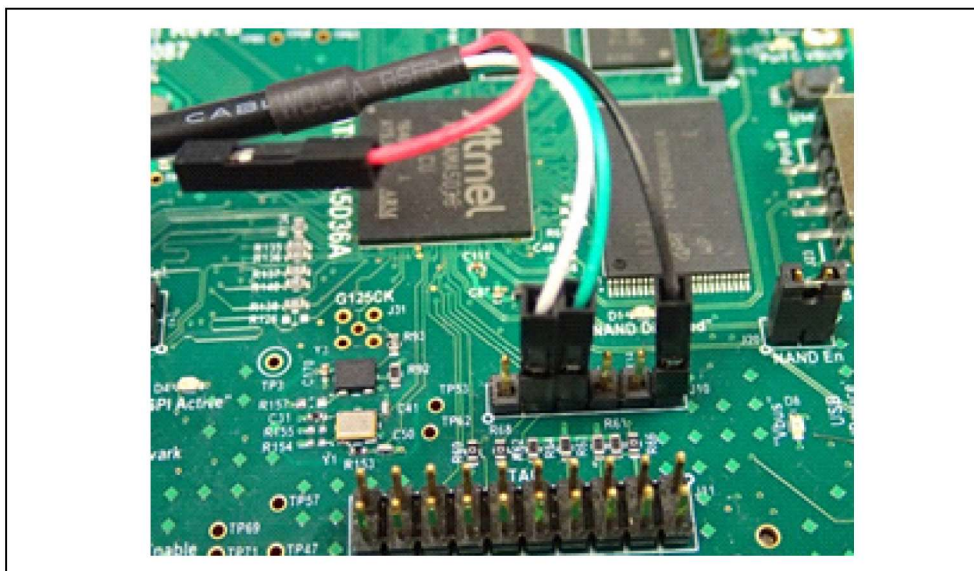
7. The Linux file system root is located with command: `cd /`

## 4.2.2 USB-to-Serial Communication Option

This option provides direct access to the SAMA5D3 MPU via a UART interface. It does not require knowledge of the IP address and setting the IP address on the PC. In addition, it does not depend on a switch or PHY daughter board being attached to the SAMA5D3 EDS board.

1. Get a USB-to-serial cable and install the PC driver if necessary. Examples are the Microchip PICKIT™ Serial Analyzer, the USB-to-TTL Serial Cable from Adafruit (Product ID 954), and the FTDI TTL-232R-3V3 or TTL-232R-5V.
2. Connect the USB-to-serial cable to header J10 on the SAMA5D3 EDS board.
  - a) If using the Adafruit USB-to-Serial Cable (Product ID 954), connect white to J10 pin 2, green to pin 3, and black to pin 6. Red is not used. See [Figure 4-2](#).

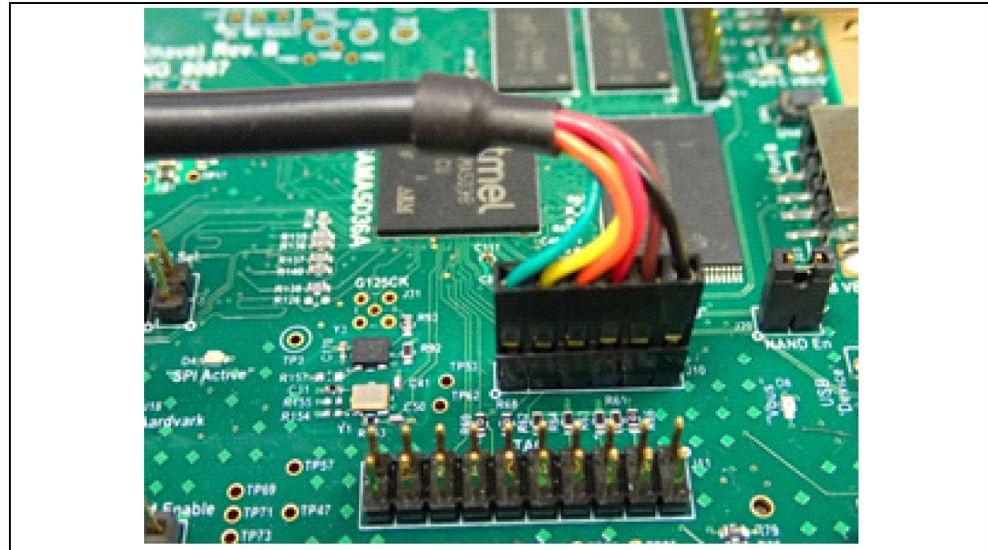
FIGURE 4-2: ADAFRUIT USB-SERIAL CABLE CONNECTION TO HEADER J10



- b) If using a TTL-232R cable from FTDI, the 6-pin SIL connector on the cable plugs directly into J10 on the board, with green at J10 pin 1 and black at J10 pin 6. See [Figure 4-3](#).

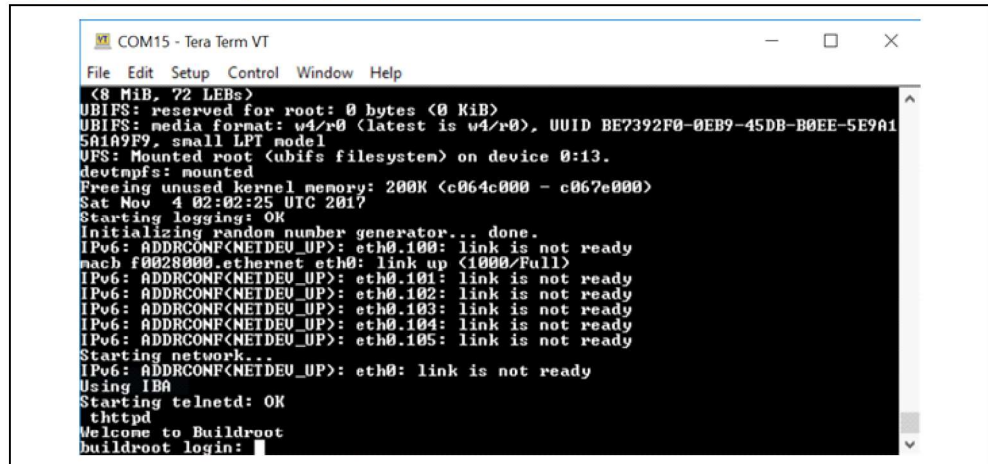
# Software Configuration and Operation

FIGURE 4-3: FTDI TTL-232R USB-SERIAL CABLE CONNECTION TO HEADER J10



3. On the PC, open a serial port session using TeraTerm, PuTTY or similar communication software. The settings are 115200 baud, 8 bits, no parity, 1 Stop bit (8N1).
4. The MPU outputs text as shown in [Figure 4-4](#) when it powers up.

FIGURE 4-4: LINUX LOGIN PROMPT



5. The login is "root" (no quotes). No password is required.
6. The Linux file system root is located with command: `cd /`

## 4.3 SOFTWARE VERSION

The software installed on the board may not be the latest revision. Users are encouraged to compare the installed software version with the latest version available on the Microchip website and update it if necessary. The software version can be checked as follows:

```
# cat/sys/class/net/eth0/sw/version
```

# SAMA5D3 Ethernet Development System User's Guide

---

## 4.4 IP AND MAC ADDRESSES

All SAMA5D3 EDS boards currently come with the same IP and MAC addresses. Use the `ipaddr` or `ifconfig` commands to check the IP and MAC addresses:

```
# ipaddr or # ifconfig
```

Either address may be changed at the bootloader level as described in [Section 4.5 “Ethernet Device Register Address”](#).

## 4.5 ETHERNET DEVICE REGISTER ADDRESS

When logged into Linux on the board, the registers of the Ethernet switch or PHY on the attached daughter board can be accessed using the `regs_bin` utility. The *KSZ Switch Utilities User's Guide* provides more details about `regs_bin` and other utilities for certain KSZ switches.

Below is an example of byte, word and double-word reads and writes using `regs_bin`.

```
# regs_bin spi0.0
> rb 302 // byte read
0000: 00
> rw 302 // word read
0000: 00 10
> rd 302 // double word read
0302: 00 10 a1 94
> wb 302 87 // byte write
> rd 302
0302: 87 10 a1 94
> ww 304 88 99 // word write
> rd 302
0302: 87 10 88 99
> wd 302 38 47 56 65 // double word write
> rd 302
0302: 38 47 56 65
> q
#
```

## 4.6 ETHERNET SWITCH MIB COUNTERS

When a switch daughter board is connected to the SAMA5D3 EDS board, the driver makes the per-port MIB counters available for reading.

```
# cat /sys/class/net/eth0/sw0/0_mib // read MIB counters for port 1
# cat /sys/class/net/eth0/sw1/1_mib // read MIB counters for port 2
# cat /sys/class/net/eth0/sw2/2_mib // read MIB counters for port 3
```

To clear the MIB counters for individual ports:

```
# echo 0 > /sys/class/net/eth0/sw0/0_mib // clear MIB counters for port 1
# echo 0 > /sys/class/net/eth0/sw1/1_mib // clear MIB counters for port 2
# echo 0 > /sys/class/net/eth0/sw2/2_mib // clear MIB counters for port 3
```



# Software Configuration and Operation

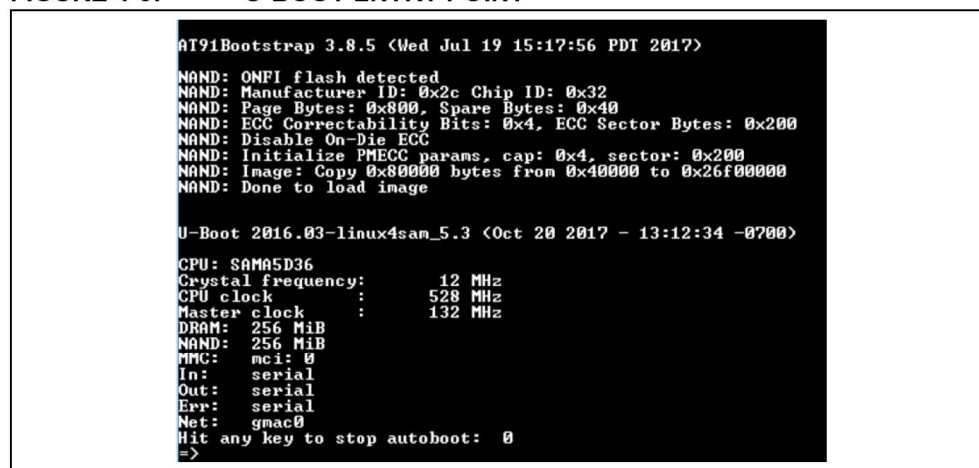
To clear the MIB counters for all ports at once:

```
# echo 0 > /sys/class/net/eth0/sw/mib // clear MIB counters for all ports
```

## 4.7 BOOTLOADER SETTINGS

Several variables, including device addresses, can be set in the U-Boot bootloader. To access the boot loader settings, either reboot the processor with the “reboot” command or press the reset button (SW1) on the board. Then, quickly press any keyboard key early in the boot process at the message, “Hit any key to stop autoboot,” as shown in Figure 4.5.

FIGURE 4-5: U-BOOT ENTRY POINT



```
AT91Bootstrap 3.8.5 (Wed Jul 19 15:17:56 PDT 2017)
NAND: ONFI flash detected
NAND: Manufacturer ID: 0x2c Chip ID: 0x32
NAND: Page Bytes: 0x800, Spare Bytes: 0x40
NAND: ECC Correctability Bits: 0x4, ECC Sector Bytes: 0x200
NAND: Disable On-Die ECC
NAND: Initialize PMECC params, cap: 0x4, sector: 0x200
NAND: Image: Copy 0x80000 bytes from 0x40000 to 0x26f00000
NAND: Done to load image

U-Boot 2016.03-linux4sam_5.3 (Oct 20 2017 - 13:12:34 -0700)

CPU: SAMA5D36
Crystal frequency: 12 MHz
CPU clock : 528 MHz
Master clock : 132 MHz
DRAM: 256 MiB
NAND: 256 MiB
MMC: mci: 0
In: serial
Out: serial
Err: serial
Net: gmac0
Hit any key to stop autoboot: 0
=>
```

Type “print” to see a listing of environment variable settings. Below are examples of how to set some variables. To make the changes permanent, use the “saveenv” command after making the changes.

```
=> print // optional, show the environment variable settings
=> setenv ethaddr 00:10:A1:94:77:01 // sets the MAC address
=> setenv ipaddr 192.168.0.201 // sets the IP address
=> saveenv // saves settings to NV memory
=> boot
```

## 4.8 AUTOMATICALLY RUNNING PROCESS

Depending on the software revision and the attached Ethernet daughter board, some processes such as AVB or RSTP may be set to run automatically when the system is powered up. To check if they are running, read the appropriate files in the folder /sys/class/net/eth0/sw

```
# cat /sys/class/net/eth0/sw/avb
# cat /sys/class/net/eth0/sw/stp
```

They can be disabled at the bootloader:

```
=> setenv avb 0 // disable AVB
=> setenv multi_dev 3 // bug workaround to enable STP control
=> setenv stp 0 // disable RSTP
=> saveenv // saves settings to NV memory
```

## 4.9 PRECISION TIME PROTOCOL (IEEE 1588)

For switch daughter boards that support IEEE1588 Precision Time Protocol (PTP), the PTP protocol can be run by navigating to the appropriate file system directory, then running the script found there. There are directories for end-to-end (e2e) and peer-to-peer (p2P). The default.cfg file found in the e2e and p2p directories can be edited to change the PTP parameters. Additional details can be found in the software setup guide for the given switch.

```
# cd /ptp/e2e
# cd /ptp/p2p
# /linuxptp.sh
```

## 4.10 VLAN SETUP

VLAN control of switches is handled through the driver. The user can access the driver's VLAN functions via files located at `/sys/class/net/eth0/sw`. Reading `/sys/class/net/eth0/sw/vlan_table` shows the valid entries in the VLAN table. See the appropriate switch reference guide for further details.

## 4.11 DHCP

To enable DHCP, change the word "static" to "dhcp" in the file `/etc/network/interfaces`.

## 4.12 NUTTCP TRAFFIC TESTING

The Linux installation includes the nuttcp utility, which has similar capabilities as iperf. If you install nuttcp on another device such as a PC, you can perform traffic testing between the two devices. A help menu is included. Additional details about nuttcp can be found on the Internet.

---

---

## Appendix A. Programming the SAMA5D3 EDS Board

---

---

### A.1 INTRODUCTION

The software installed on the board may not be the most recent, so users should check the software version as described in [Section 4.4 “IP and MAC Addresses”](#) and update it to the latest version available on the Microchip website.

### A.2 NAND FLASH PROGRAMMING

#### A.2.1 NAND Flash Programming on Linux

**Note:** The following procedure is tested with the Ubuntu x64 14.04.05 LTS distribution.

1. Open a terminal window and unzip the file to a folder (for example, /home).

```
$ unzip SAMA5D3_EDS_Images_Vxx.xx.xx.zip  
$ cd SAMA5D3_EDS_Images/linux
```

2. Connect the micro-USB (J12) connector of the SAMA5D3 EDS board to the Linux PC.
3. Connect 12V of power to the SAMA5D3 EDS board.
4. Remove the NAND enable (J20) jumper and press the reset button.  
The /dev/ttyACM0 \_\_\_\_ is created. Execute the `$ tail -f /var/log/kernel.log` command to see this.
5. Insert the NAND enable (J20) jumper.
6. If you are using an x86 system, then run the `flash_board` script in the terminal window. If you are using an x64 system, then run the `flash_board_x64` script.  

```
$ sudo flash_board (for x86 system)  
$ sudo flash_board_x64 (for x64 system)
```

7. Once “DONE” is displayed, press the reset button to reboot the SAMA5D3 EDS board.

#### A.2.2 NAND Flash Programming on Windows

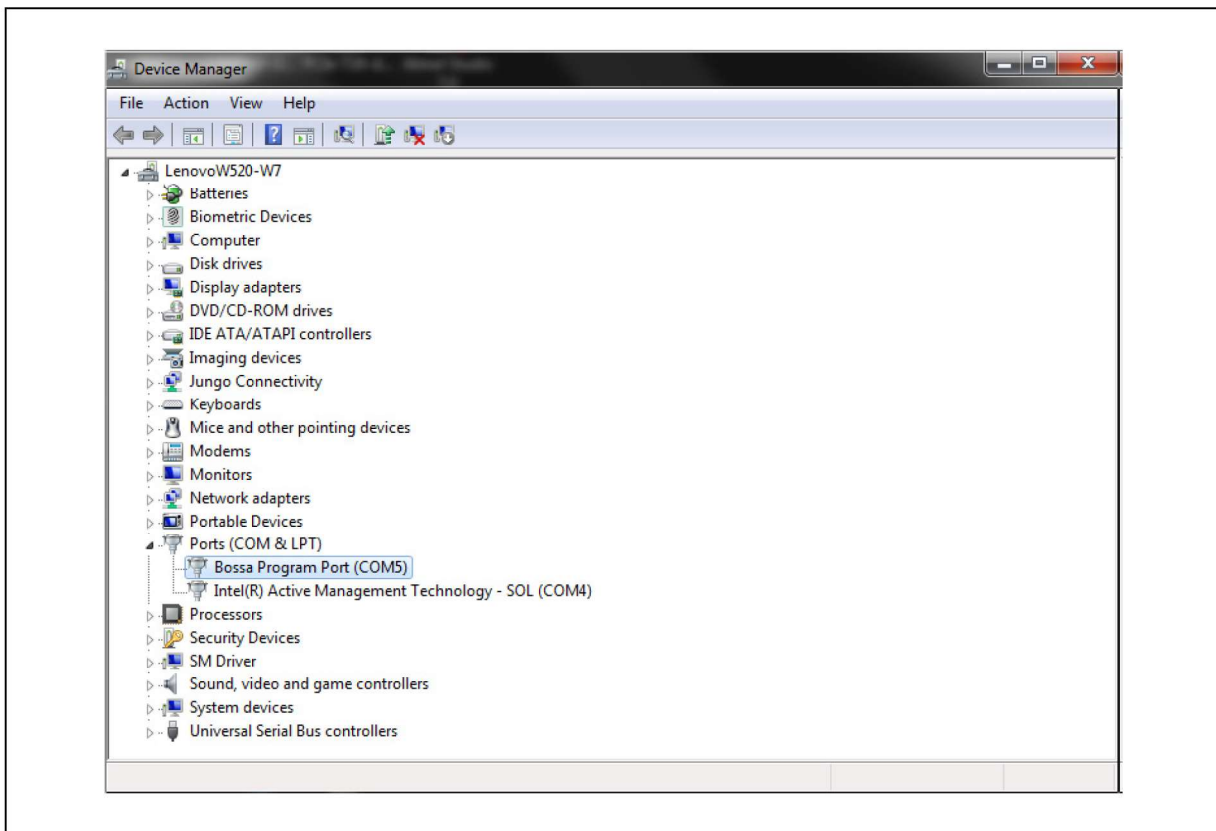
**Note:** This procedure is tested on Win7 x64 and Win10 x64 versions of Windows.

1. Unzip the zip file to a folder (for example, C:\tmp).
2. Open Command Prompt and change the `SAMA5D3_EDS_Images\windows` folder (for example, C:\tmp\SAMA5D3\_EDS\_Images\windows).
3. Connect the micro-USB (J12) connector of the SAMA5D3 EDS board to the Windows PC.
4. Connect 12V of power to the SAMA5D3 EDS board.
5. Remove the NAND enable (J20) jumper and press the reset button.
6. When the PC has Internet connection, it will install “Bossa Program Port” automatically. (The port number may be different on the system.) See [Figure A-1](#).

# SAMA5D3 Ethernet Development System User's Guide

---

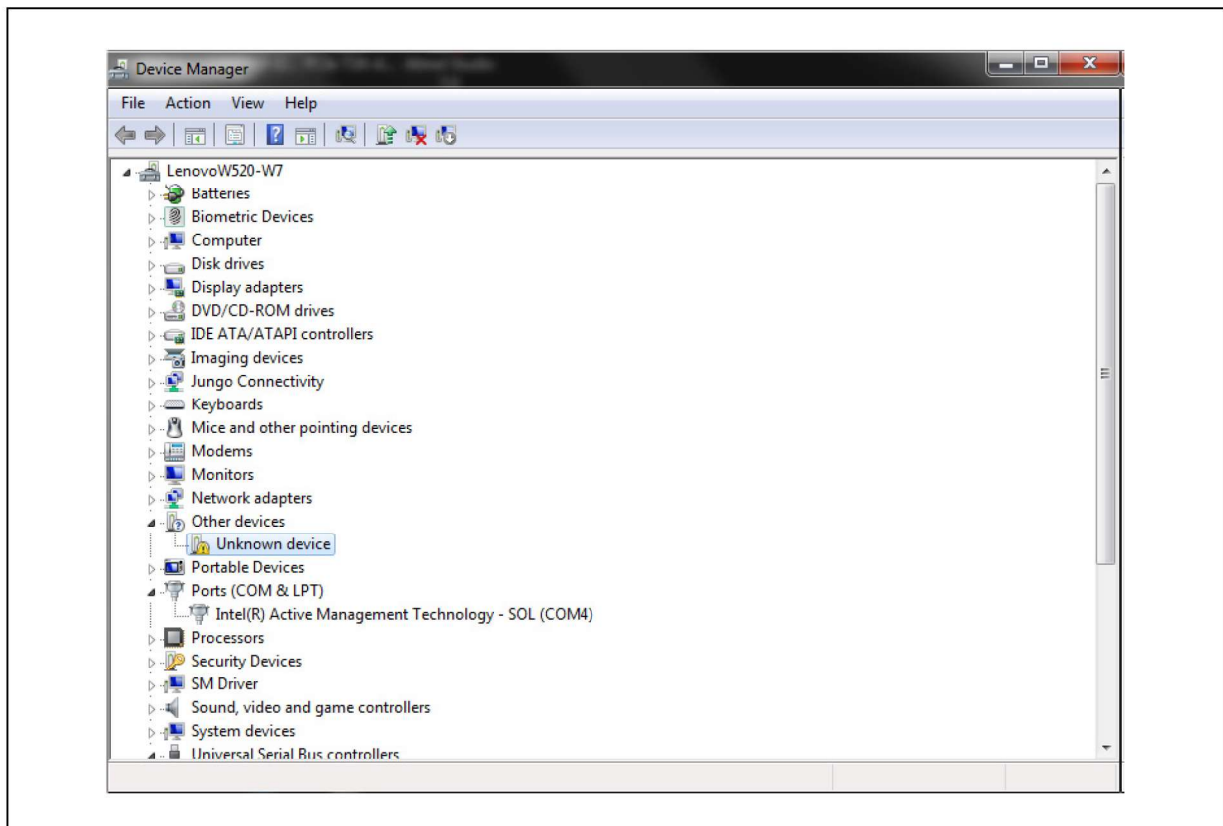
**FIGURE A-1: DEVICE MANAGER - BOSSA PROGRAM PORT INSTALLED**



7. If the PC does not have Internet connection, find "Unknown device" under "Other devices" in Device Manager and install the driver from the folder. See [Figure A-2](#):  
SAMA5D3\_EDS\_Images\windows\sam-ba\_3.1.4\driver  
(for example, C:\tmp\SAMA5D3\_EDS\_Images\windows\sam-ba\_3.1.4\driver)

# Programming the SAMA5D3 EDS Board

FIGURE A-2: DEVICE MANAGER - OTHER DEVICES>UNKNOWN DEVICE

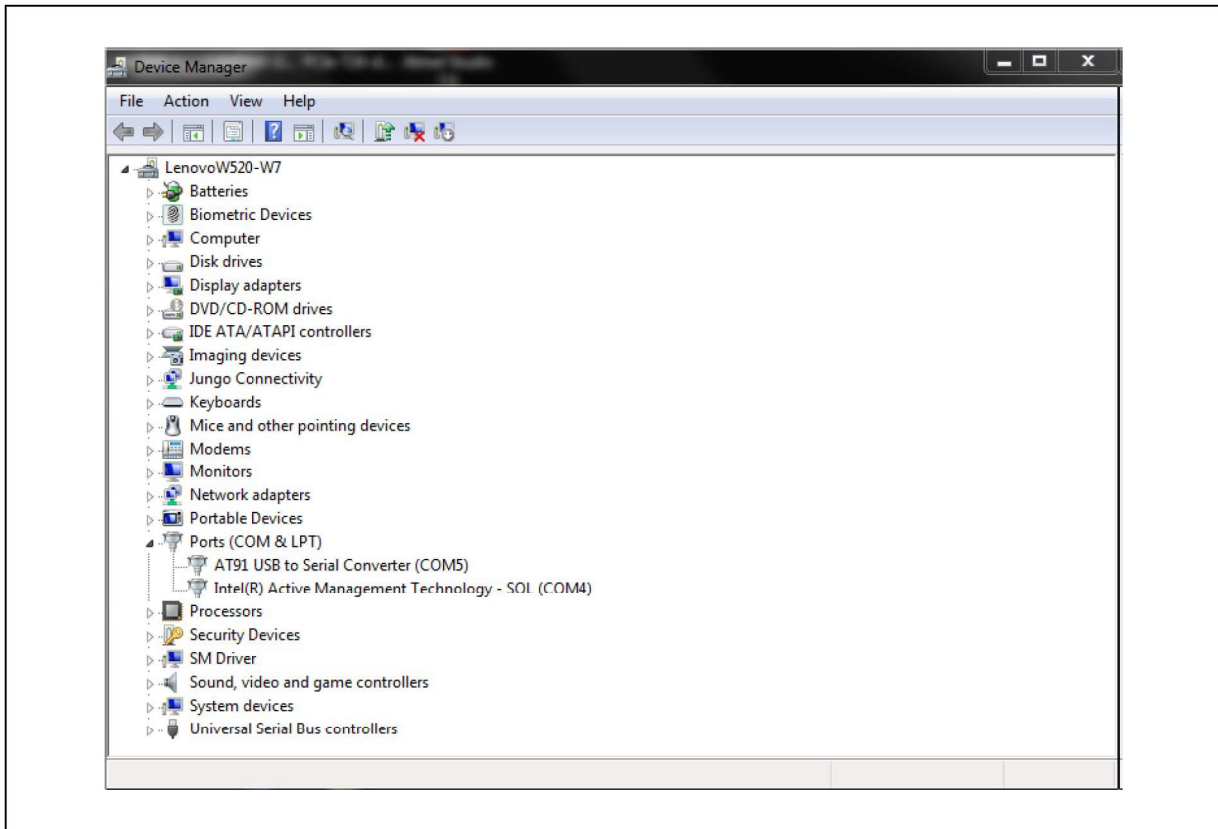


# SAMA5D3 Ethernet Development System User's Guide

---

8. After successful installation, the Device Manager window shows **AT91 USB to Serial Converter** "Ports." See [Figure A-3](#).

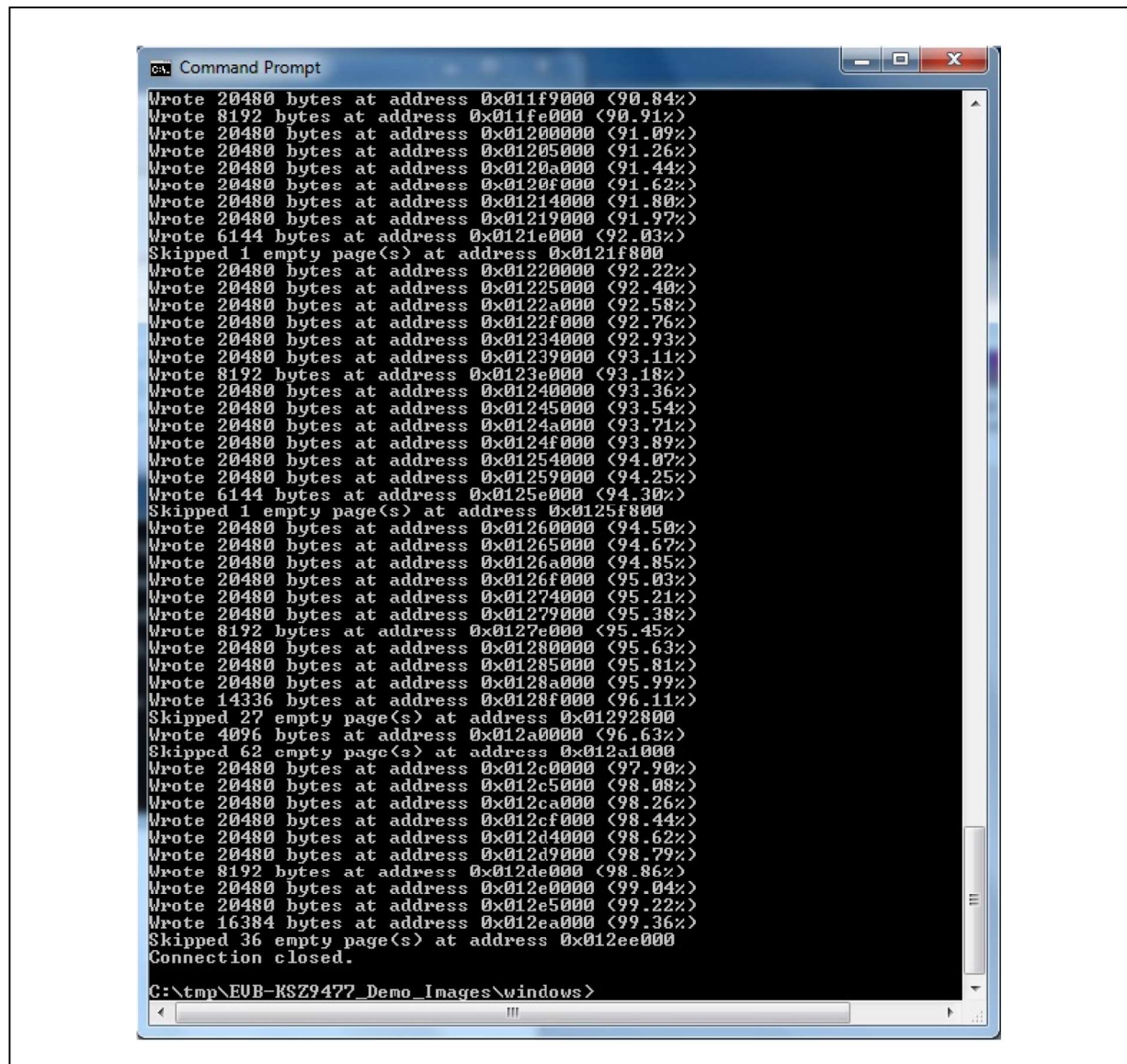
**FIGURE A-3: DEVICE MANAGER - AT91 USB TO SERIAL CONVERTER SHOWN**



9. Wait for few seconds before performing the following steps after board power-up. Make sure the device driver installation is complete. [Figure A-4](#) shows the console display after the NAND flash programming is complete. Insert the NAND enable (J20) jumper.
10. Using Command Prompt, execute `flash_board.bat` under `SAMA5D3_EDS_Images\windows` to program the NAND flash.
  - > `cd SAMA5D3_EDS_Images\windows`
  - > `flash_board.bat`

# Programming the SAMA5D3 EDS Board

FIGURE A-4: EXECUTING THE FLASH\_BOARD.BAT COMMAND IN COMMAND PROMPT

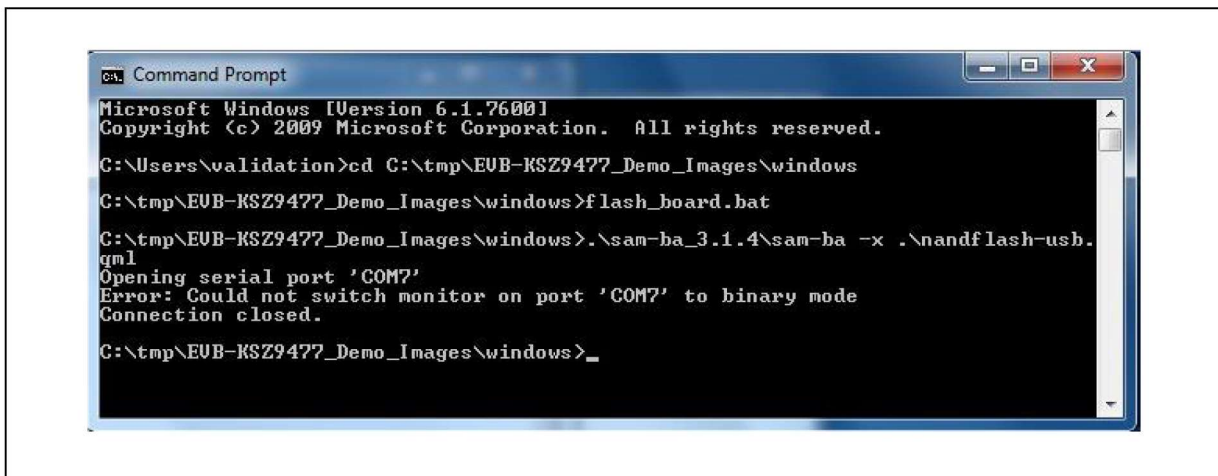


# SAMA5D3 Ethernet Development System User's Guide

---

If the error in [Figure A-5](#) appears, rerun the `flash_board.bat` command.

**FIGURE A-5: FLASH\_BOARD.BAT COMMAND ERROR**



## A.3 SD CARD IMAGE PROGRAMMING

The `SAMA5D3_ESD_Images_Vxx.xx.xx.zip` file contains an SD card image that must be flashed to the SD card. The image is available in the `SAMA5D3_ESD_Images/images` folder.

To flash images to the SD card, the Etcher tool is recommended. The tool can be downloaded from <https://etcher.io>. The Etcher tool provides the same GUI interface both for Windows and Linux.

For Windows, download and install the 32-bit installer package. This procedure is tested on Win7x64.

For Linux, download the x86 or x64 package depending on your Linux system. This procedure is tested on Ubuntu x64 14.04.05 LTS distribution.

### A.3.1 SD Card Programming

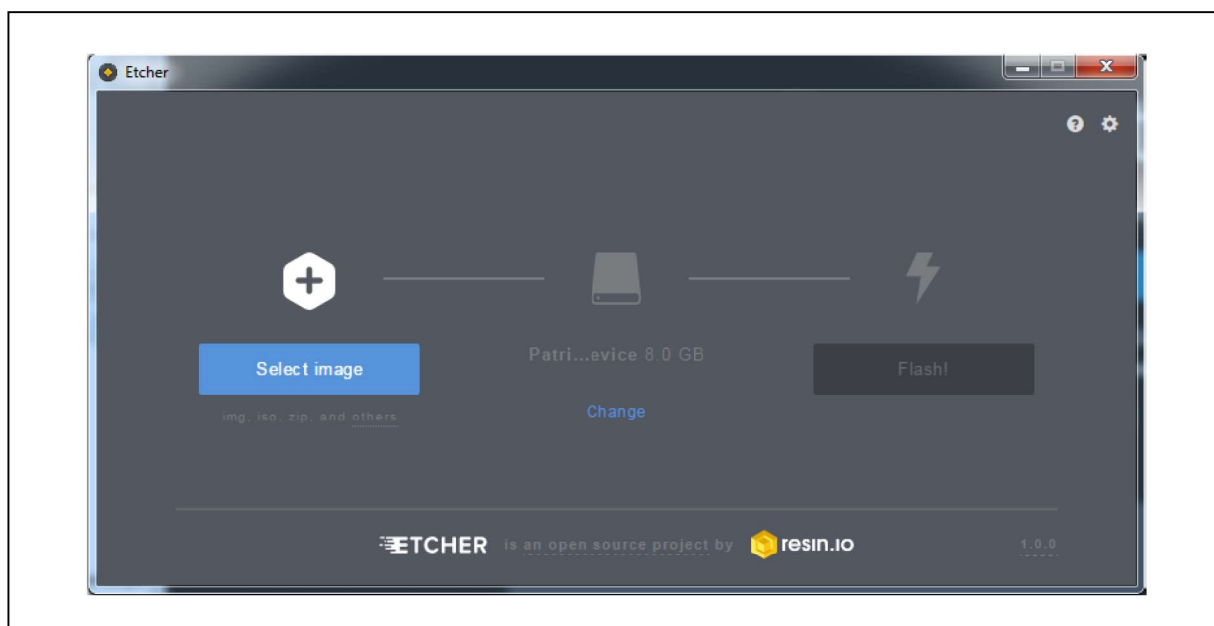
**Note:** An SD card size of 16 GB or greater is required.

1. Unzip the zip file to a folder (for example, `C:\tmp`).
2. The SD card image (`sdcard.img`) is located in the `SAMA5D3_ESD_Images/images` folder.  
(`c:\tmp\ SAMA5D3_ESD_Images\images\sdcard.img`) folder
3. Start the Etcher tool and select the image (`sdcard.img`). Make sure the appropriate SD card is selected because all the contents of the SD card will be erased.
4. Select **Flash!** to program the SD card. See [Figure A-6](#).



# Programming the SAMA5D3 EDS Board

FIGURE A-6: ETCHER TOOL



After the programming is successfully completed, the SD card can be used to boot the SAMA5D3 EDS board.

## A.4 BOOTING THE SAMA5D3 EDS

The serial communication interface must be connected to a PC using an FTDI USB-to-Serial (TTL-232R-3V3) cable. A 12-V power must also be connected to the SAMA5D3 EDS board.

### A.4.1 Booting from NAND Flash

The SAMA5D3 EDS board boots with the new image if MCU reset or power on/off is pressed after programming the NAND flash. The “buildroot login:” prompt is displayed. To open Command Prompt, enter ‘root’ and press <Enter>.

### A.4.2 Booting from SD Card

After burning the SD card, insert the SD card into the SD slot. Reset the board either using the reset button or powering on/off the board. The board boots with the SD card, and “buildroot login:” is prompted. To open Command Prompt, enter ‘root’ and press <Enter>.

# SAMA5D3 Ethernet Development System User's Guide

---

NOTES:



## Appendix B. Schematics

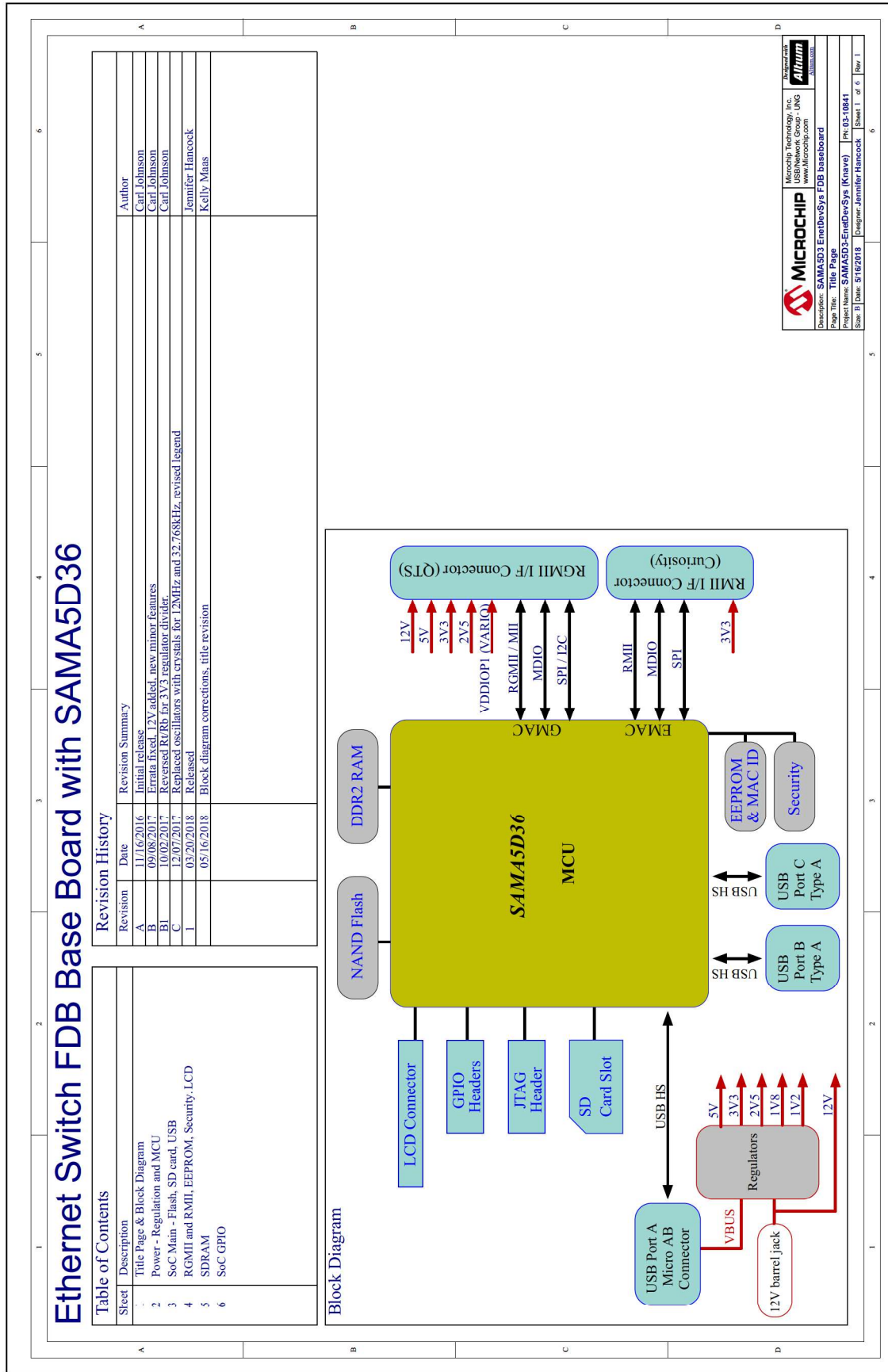
---

---

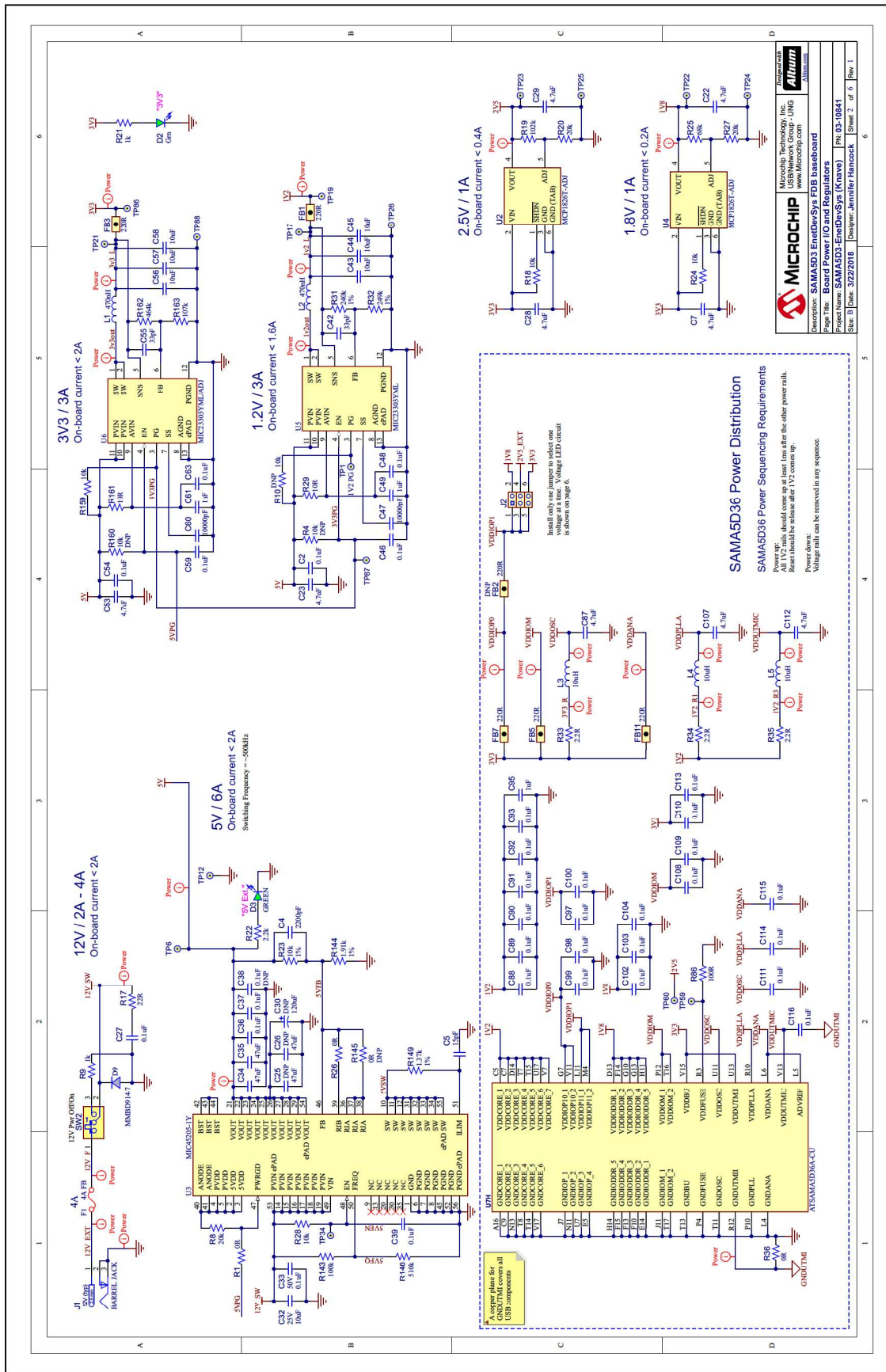
### B.1 INTRODUCTION

This appendix includes the SAMA5D3 EDS schematics. See [Figure B-1](#) to [Figure B-6](#).

**FIGURE B-1: ETHERNET SWITCH FDB BASE BOARD WITH SAMA5D36**

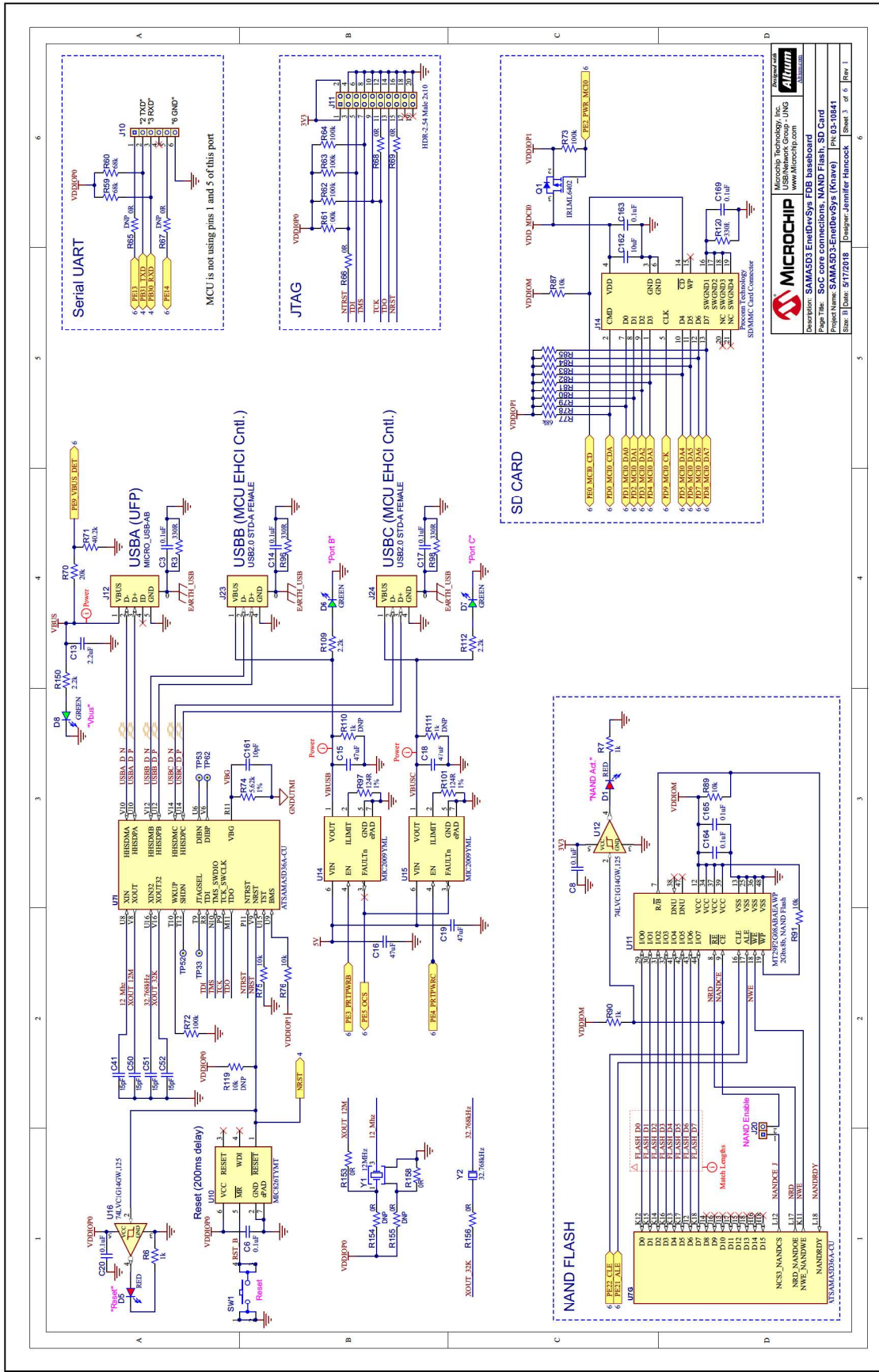


**FIGURE B-2: SAMA5D3 SCHEMATICS - BOARD POWER I/O AND REGULATORS**

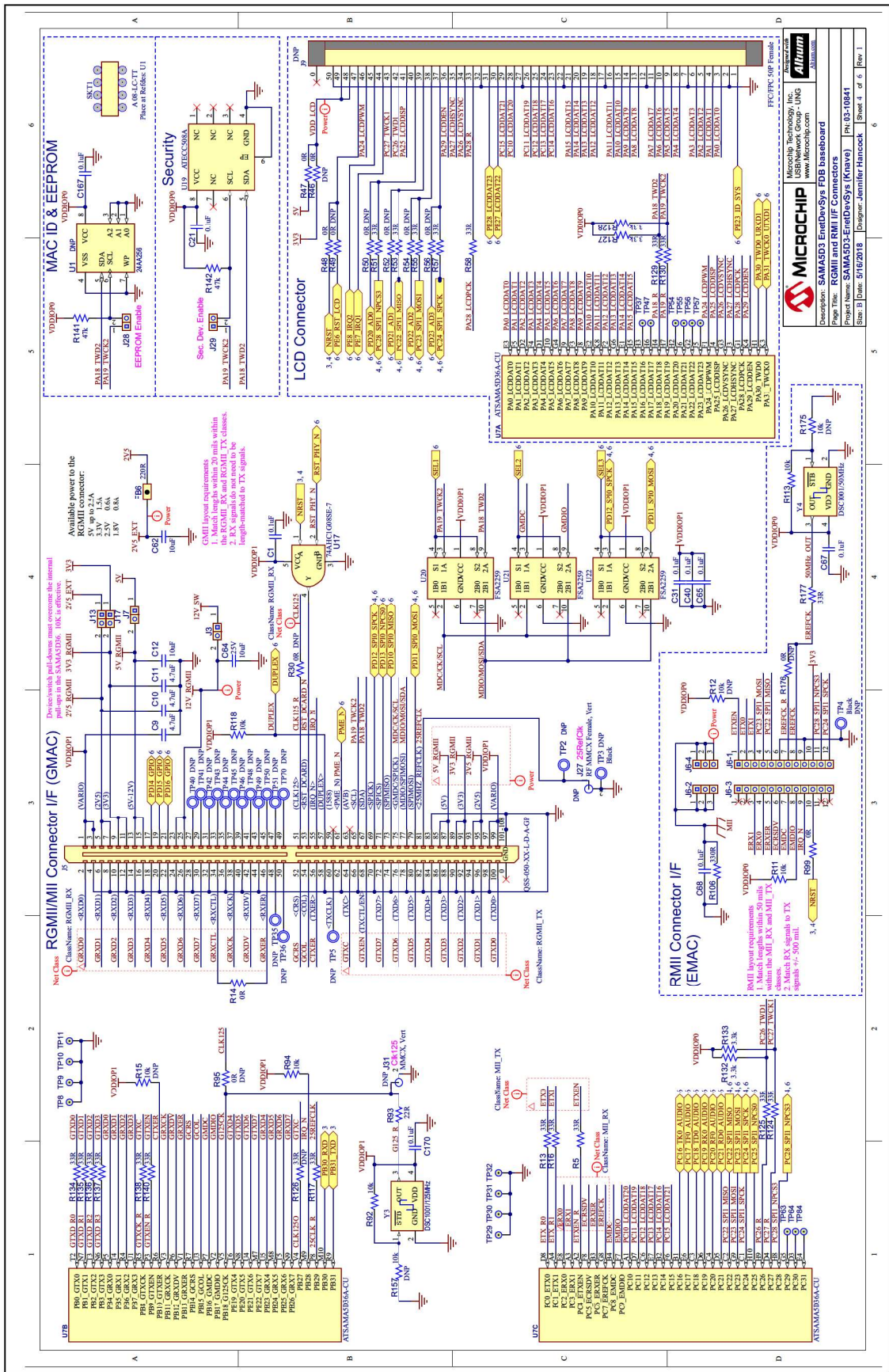


# SAMA5D3 Ethernet Development System User's Guide

**FIGURE B-3: SAMA5D3 SCHEMATICS - SOC CORE CONNECTIONS, NAND FLASH, AND SD CARD**

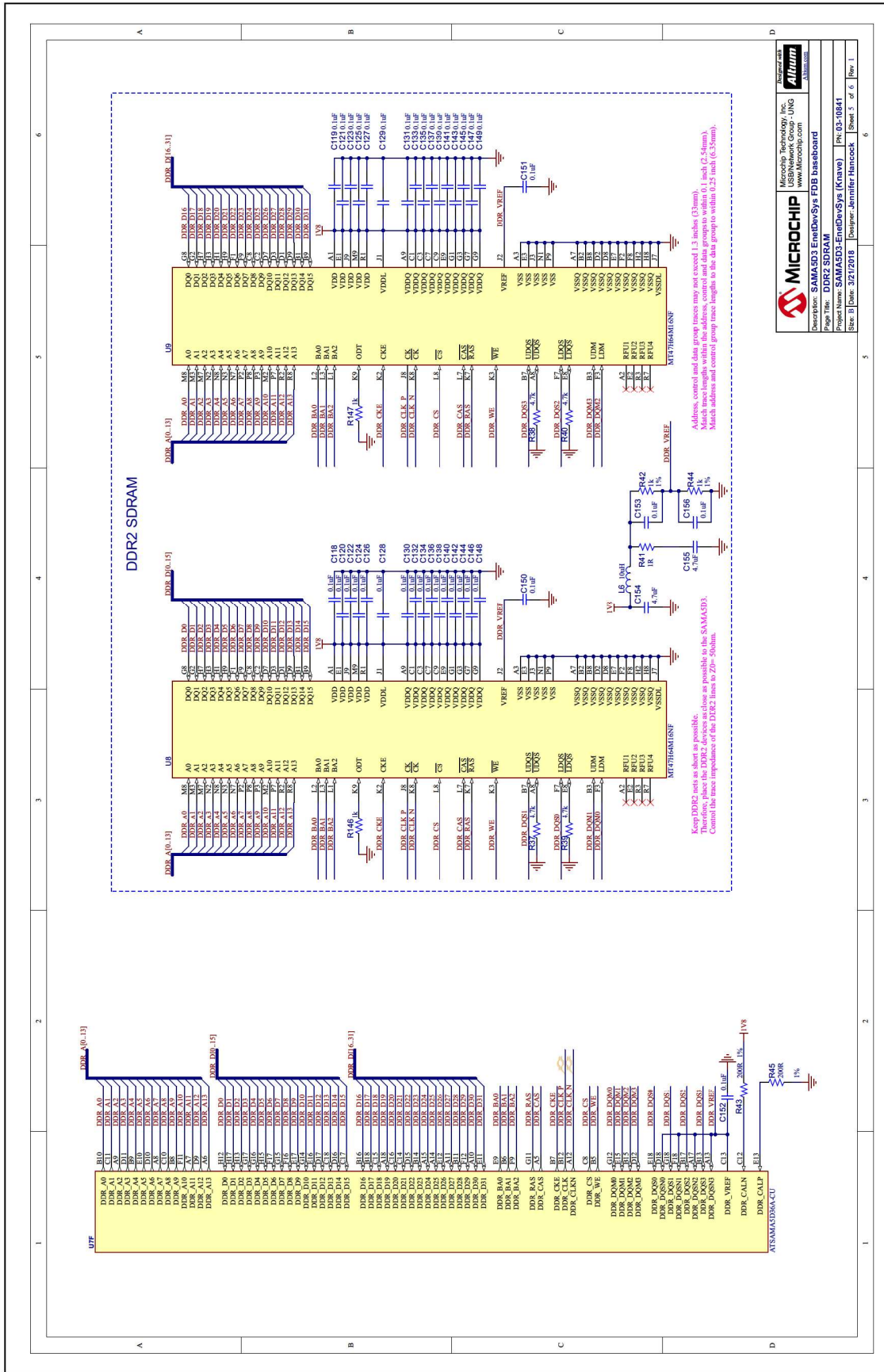


**FIGURE B-4: SAM4SD3 SCHEMATICS - RGMII AND RMII I/F CONNECTORS**



# SAMA5D3 Ethernet Development System User's Guide

FIGURE B-5: SAMA5D3 SCHEMATICS - DDR2 SDRAM



**MICROCHIP**  
Microchip Technology, Inc.  
1900 E. Chandler Blvd.  
Phoenix, AZ 85020  
www.microchip.com

Part Number: **SAMA5D3-EMDDevSys FDB baseboard**

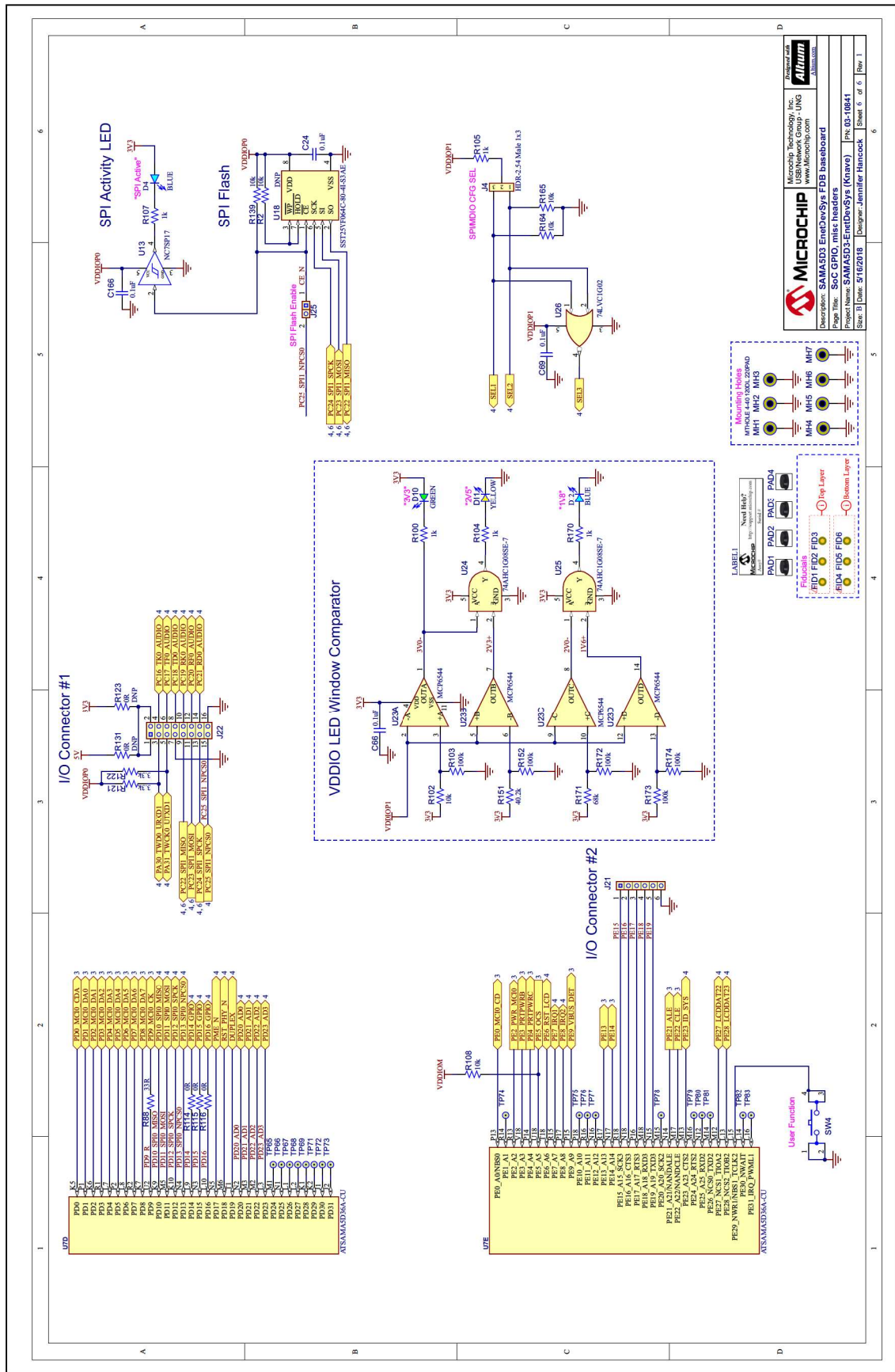
Page Title: **DDR2 SDRAM**

Project Name: **SAMA5D3-EMDDevSys (Knaave)** | PN: 03-10841

Size: 6 | Date: 3/27/2018 | Designer: Jennifer Hancock | Sheet 5 of 6 | Rev. 1



## FIGURE B-6: SAMA5D3 SCHEMATICS - SOC GPIO AND MISC HEADERS



# SAMA5D3 Ethernet Development System User's Guide

---

NOTES:



## Appendix C. Bill of Materials

---

---

### C.1 INTRODUCTION

This appendix includes the SAMA5D3 Bill of Materials (BOM). See [Table C-1](#).

# SAMA5D3 Ethernet Development System User's Guide

**TABLE C-1: BILL OF MATERIALS**

Item	Qty	Reference	Description	Populated	Manufacturer	Manufacturer Part Number
1	92	C1, C2, C3, C6, C8, C14, C17, C20, C21, C24, C27, C31, C33, C36, C37, C39, C40, C46, C48, C54, C59, C63, C65, C66, C67, C68, C69, C88, C89, C90, C91, C92, C93, C97, C98, C99, C100, C102, C103, C104, C108, C109, C110, C111, C113, C114, C115, C116, C118, C119, C120, C121, C122, C123, C124, C125, C126, C127, C128, C129, C130, C131, C132, C133, C134, C135, C136, C137, C138, C139, C140, C141, C142, C143, C144, C145, C146, C147, C148, C149, C150, C151, C152, C153, C156, C163, C164, C165, C166, C167, C169, C170	CAP CER 0.1 uF 50V 10% X7R SMD 0402	YES	TDK Corporation	C1005X7R1H104K050BB
2	1	C4	CAP CER 2200 pF 25V 5% COG SMD 0402	YES	KEMET	C0402C222J3GACTU
3	5	C5, C41, C50, C51, C52	CAP CER 15 pF 50V 5% NP0 SMD 0402	Yes	Murata Electronics North America	GRM1555C1H150JA01D
4	14	C7, C9, C10, C11, C22, C23, C28, C29, C53, C87, C107, C112, C154, C155	CAP CER 4.7 uF 6.3V 20% X5R SMD 0402	YES	Murata Electronics North America	GRM155R60J475ME47D
5	9	C12, C43, C44, C45, C56, C57, C58, C62, C162	CAP CER 10 uF 6.3V 20% X5R SMD 0603	Yes	AVX	06036D106MAT2A
6	1	C13	CAP CER 2.2 uF 16V 10% X5R SMD 0603	Yes	TDK Corporation	C1608X5R1C225K
7	6	C15, C16, C18, C19, C34, C35	CAP CER 47 uF 10V 20% X5R SMD 1206	Yes	KEMET	C1206C47M8PACTU
8	2	C32, C64	CAP CER 10 uF 25V 20% X5R SMD 0603	YES	Murata Electronics North America	GRM188R61E106MA73D
9	2	C42, C55	CAP CER 33 pF 50V 5% NP0 SMD 0402	YES	Murata Electronics North America	GRM1555C1H330JA01D
10	2	C47, C60	CAP CER 10000 pF 16V 10% X7R SMD 0402	YES	KEMET	C0402C103K4RACTU
11	3	C49, C61, C95	CAP CER 1 uF 16V 10% X5R SMD 0402	YES	TDK Corporation	C1005X5R1C105K
12	1	C161	CAP CER 10 pF 50V 5% NP0 SMD 0402	Yes	Murata Electronics North America	GRM1555C1H100JZ01D
13	2	D1, D5	DIO LED RED 2V 30 mA 2 mcd Clear SMD 0603	YES	Lite-On	LTST-C190EKT
14	6	D2, D3, D6, D7, D8, D10	DIO LED GREEN 2V 30 mA 35 mcd Clear SMD 0603	YES	Lite-On Inc.	LTST-C191KGGT
15	2	D4, D12	DIO LED BLUE 3.3V 20 mA 180 mcd Clear SMD 0603	YES	Kingbright	APT1608VBC/D
16	1	D9	DIO RECT MMBD914-7-F 1.25V 200 mA 75V SMD SOT-23-3	YES	Diodes Incorporated	MMBD914-7-F
17	1	D11	DIO LED YELLOW 2.1V 20 mA 6 mcd Clear SMD 0603	YES	Lite-On	LTST-C190YKT
18	1	F1	RES FUSE 4A 125VAC/DC FAST SMD 2-SMD	YES	Littelfuse Inc.	0154004.DR
19	6	FB1, FB3, FB5, FB6, FB7, FB11	FERRITE 220R at 100 MHz 2A SMD 0603	YES	Murata Electronics North America	BLM18EG221SN1D
20	1	J1	CON JACK Power Barrel Black Male TH RA	YES	CUI Inc.	PJ-002BH
21	1	J2	CON HDR-2.54 Male 2x3 Gold 5.84 MH TH VERT	Yes	Samtec Inc.	TSW-103-08-L-D
22	8	J3, J7, J13, J17, J20, J25, J28, J29	CON HDR-2.54 Male 1x2 Gold 5.84 MH TH VERT	Yes	FCI	77311-118-02LF
23	1	J4	CON HDR-2.54 Male 1x3 Tin 5.84 MH TH VERT	Yes	Samtec Inc.	TSW-103-07-T-S
24	1	J5	CON STRIP High Speed Stacker 6.36 mm Female 2x50 SMD VERT	YES	Samtec Inc.	QSS-050-01-L-D-A-GP
25	2	J6-1, J6-3	CON HDR-1.27 FEMALE 1x12 TH VERT	YES	Sullins Connector Solutions	LPPB121NFFN-RC
26	2	J6-2, J6-4	CON HDR-1.27 FEMALE 1x3 TH VERT	YES	Sullins Connector Solutions	LPPB031NFFN-RC

**TABLE C-1: BILL OF MATERIALS (CONTINUED)**

Item	Qty	Reference	Description	Populated	Manufacturer	Manufacturer Part Number
27	2	J10, J21	CON HDR-2.54 Male 1x6 Gold 5.84 MH TH VERT	Yes	FCI	68000-106HLF
28	1	J11	CON HDR-2.54 Male 2x10 Gold 5.84 MH TH VER	YES	Samtec Inc.	TSW-110-07-G-D-020
29	1	J12	CON USB2.0 MICRO-AB FEMALE SMD R/A	YES	Hirose	ZX62-AB-5PA(31)
30	1	J14	CON FLASH SD/MMC 16P PUSH-PULL SMD R/A	YES	Procconn Technology Co, Ltd	SDC013-A0-5002
31	1	J22	CON HDR-2.54 Male 2x8 Gold 5.84 MH TH VERT	Yes	FCI	68602-116HLF
32	2	J23, J24	CON USB2.0 STD-A FEMALE SMD R/A	YES	ASSMANN Electronic	AU-Y1006-R
33	2	L1, L2	INDUCTOR 470 nH 4.5A 20% SMD 1008	YES	ICE Components Inc.	IPC-2520AB-R47-M
34	4	L3, L4, L5, L6	INDUCTOR 10 uH 80 mA 10% SMD 0603	YES	Taiyo Yuden	LBMF1608T100K
35	1	Q1	TRANS FET P-CH IRLML6402 -20V -3.7A 1.3W SOT-23-3	YES	International Rectifier	IRLML6402TRPBF
36	13	R1, R14, R26, R36, R47, R48, R66, R69, R99, R114, R115, R116	RES TKF 0R 1/10W SMD 0603	Yes	Panasonic Electronic Components	ERJ-3GSY0R00V
37	21	R2, R11, R18, R23, R24, R28, R75, R76, R87, R89, R91, R92, R94, R102, R108, R113, R118, R139, R159, R164, R165	RES TKF 10k 1% 1/10W SMD 0603	Yes	Panasonic Electronic Components	ERJ-3EKF1002V
38	5	R3, R96, R98, R106, R120	RES TKF 330R 5% 1/10W SMD 0603	Yes	Panasonic Electronic Components	ERJ-3GEYJ331V
39	21	R5, R13, R16, R51, R53, R55, R57, R58, R88, R117, R124, R125, R129, R130, R134, R135, R136, R137, R138, R140, R177	RES TKF 33R 5% 1/10W SMD 0603	Yes	Panasonic Electronic Components	ERJ-3GEYJ330V
40	14	R6, R7, R9, R21, R42, R44, R90, R100, R104, R105, R107, R146, R147, R170	RES TKF 1k 1% 1/10W SMD 0603	Yes	Panasonic Electronic Components	ERJ-3EKF1001V
41	4	R8, R20, R27, R70	RES TKF 20k 1% 1/10W SMD 0603	Yes	Panasonic Electronic Components	ERJ-3EKF2002V
42	2	R17, R93	RES TKF 22R 1% 1/10W SMD 0603	YES	Yageo	RC0603FR-0722RL
43	1	R19	RES TKF 102k 1/10W 1% SMD 0603	YES	Panasonic Electronic Components	ERJ-3EKF2201V
44	4	R22, R109, R112, R150	RES TKF 2.2k 1% 1/10W SMD 0603	Yes	Panasonic Electronic Components	ERJ-3EKF2201V
45	13	R25, R59, R60, R77, R78, R79, R80, R81, R82, R83, R84, R85, R171	RES TKF 68k 1% 1/10W SMD 0603	Yes	Stackpole Electronics Inc.	RMCF0603FT68K0
46	2	R29, R161	RES TKF 10R 1% 1/10W SMD 0603	Yes	Stackpole Electronics Inc.	RMCF0603FT10R0
47	1	R31	RES TKF 240k 1% 1/10W SMD 0603	YES	Panasonic Electronic Components	ERJ-3EKF2403V
48	1	R32	RES TKF 249k 1% 1/10W SMD 0603	Yes	Panasonic Electronic Components	ERJ-3EKF2493V
49	3	R33, R34, R35	RES TKF 2.2R 5% 1/10W SMD 0603	YES	Stackpole Electronics Inc.	RMCF0603JT2R20
50	4	R37, R38, R39, R40	RES TKF 4.7k 1% 1/10W SMD 0603	Yes	ROHM	MCR03EZPFX4701
51	1	R41	RES TKF 1R 1% 1/10W SMD 0603	YES	Yageo	RC0603FR-071RL
52	2	R43, R45	RES TKF 200R 1% 1/10W SMD 0603	Yes	Yageo	RC0603FR-07200RL
53	12	R61, R62, R63, R64, R72, R73, R103, R143, R152, R172, R173, R174	RES TKF 100k 1% 1/10W SMD 0603	Yes	Panasonic Electronic Components	ERJ-3EKF1003V
54	2	R71, R151	RES TKF 40.2k 1% 1/10W SMD 0603	YES	Yageo	RC0603FR-0740K2L
55	1	R74	RES TKF 5.62k 1% 1/16W SMD 0402	YES	Vishay Dale	CRCW04025K62FKED
56	1	R86	RES TKF 100R 1% 1/10W SMD 0603	Yes	Panasonic Electronic Components	ERJ-3EKF1000V
57	2	R97, R101	RES TKF 124R 1% 1/10W SMD 0603	YES	Panasonic Electronic Components	ERJ-3EKF1240V

# SAMA5D3 Ethernet Development System User's Guide

**TABLE C-1: BILL OF MATERIALS (CONTINUED)**

Item	Qty	Reference	Description	Populated	Manufacturer	Manufacturer Part Number
58	6	R121, R122, R127, R128, R132, R133	RES TKF 3.3k 5% 1/10W SMD 0603	Yes	Panasonic Electronic Components	ERJ-3GSYJ332V
59	2	R141, R142	RES TKF 47k 1% 1/10W SMD 0603	YES	Panasonic Electronic Components	ERJ-3EKF4702V
60	1	R144	RES TKF 1.91k 1% 1/10W SMD 0603	YES	Panasonic Electronic Components	ERJ-3EKF1911V
61	1	R148	RES TKF 510k 1% 1/10W SMD 0603	Yes	Panasonic Electronic Components	ERJ-3EKF5103V
62	1	R149	RES TKF 1.37k 1% 1/10W SMD 0603	Yes	Yageo	RC0603FR-071K37L
63	3	R153, R156, R158	RES TKF 0R 1/16W SMD 0402	Yes	Yageo	RC0402JR-070RL
64	1	R162	RES TKF 464k 1% 1/10W SMD 0603	Yes	Yageo	RC0402JR-070RL
65	1	R163	RES TKF 107k 1% 1/10W SMD 0603	YES	Panasonic Electronic Components	ERJ-3EKF1073V
66	1	SKT1	SOCKET IC PUSH DIP 8 TH	YES	Assmann WSW Components	A 08-LC-TT
67	2	SW1, SW4	SWITCH TACT SPST 16V 50 mA PTS810 SJM 250 SMTR LFS SMD	YES	C&K Components	PTS810 SJM 250 SMTR LFS
68	1	SW2	SWITCH SLIDE SPDT 120V 6A 1101M2S3CQE2	YES	C&K Components	1101M2S3CQE2
69	2	U2, U4	MCHP ANALOG LDO ADJ MCP1826T-ADJE/DC SO <sup>T</sup> -223-5	YES	Microchip Technology Inc.	MCP1826T-ADJE/DC
70	1	U3	MICR ANALOG SWITCHER Buck 0.8-5.5V MIC45205-1YMP-T1 QFN-52	YES	Microchip Technology Inc.	MIC45205-1YMP-T1
71	2	U5, U6	MCHP ANALOG SWITCHER ADJ MIC23303YML DFN-12	YES	Microchip Technology Inc.	MIC23303YML-T5
72	1	U7	MCHP MCU 32-BIT 536 MHz 160KB AT SAMA5D36A-CU LFBGA-324	YES	Microchip Technology Inc.	ATSAMA5D36A-CU
73	2	U8, U9	IC MEMORY MT47H64M16NF-25E SDRAM 1 GBIT 400 Mhz FBGA-84	YES	Microchip Technology Inc.	MT47H64M16NF-25E:M
74	1	U10	MCHP ANALOG SUPERVISOR 3.075V MIC826TYMT TDFN-6	YES	Microchip Technology Inc.	MIC826TYMT-TR
75	1	U11	IC MEMORY MT29F2G08ABAEAWP-IT:E TR FLASH NAND 2GB TSOP-48	YES	Micron Technology Inc.	MT29F2G08ABAEAWP-IT:E TR
76	2	U12, U16	74LVC1G14GW,125 SCHMITT-TRG INVERTER	YES	NXP	74LVC1G14GW,125
77	1	U13	IC BUFFER NC7SP17 SC-70-5	Yes	Fairchild Semiconductor	NC7SP17P5X
78	2	U14, U15	MCHP ANALOG POWER SWITCH 5.5V 2A MIC2009YML-TR MLF-6	YES	Microchip Technology Inc.	MIC2009YML-TR
79	3	U17, U24, U25	IC LOGIC 74AHC1G08SE-7 SC-70-5	Yes	Diodes Inc.	74AHC1G08SE-7
80	1	U19	IC INTERFACE ATECC508A UDFN-8	YES	Microchip Technology Inc.	ATECC508A-MAHDA-T
81	3	U20, U21, U22	IC SWITCH FSA2259 DUAL SPDT 10UMLP	YES	ON Semiconductor	FSA2259UMX
82	1	U23	MCHP ANALOG COMPARATOR 4-CH MCP6544-E/ST TSSOP-14	Yes	Microchip Technology Inc.	MCP6544T-E/ST
83	1	U26	IC 2-INPUT NOR GATE SOT-23-5	YES	Texas Instruments	SN74LVC1G02DBVR
84	1	Y1	CRYSTAL 12 MHz 10 pF SMD L3.2WZ.4H0.7	YES	TXC Corporation	7M-12.000MEEQ-T
85	1	Y2	CRYSTAL 32.768 kHz 12.5 pF SMD ABS07	YES	Seiko	SC32S-12.5PF20PPM
86	1	Y3	MCHP CLOCK OSCILLATOR 125 MHz DSC1001C12 DFN-4	YES	Microchip Technology Inc.	DSC1001C12-125.0000T
87	1	Y4	MCHP CLOCK OSCILLATOR 50 MHz DSC1001C12 DFN-4	YES	Microchip Technology Inc.	DSC1001C12-050.0000T

---

---

**NOTES:**



# MICROCHIP

## Worldwide Sales and Service

### AMERICAS

**Corporate Office**  
2355 West Chandler Blvd.  
Chandler, AZ 85224-6199  
Tel: 480-792-7200  
Fax: 480-792-7277  
Technical Support:  
[http://www.microchip.com/  
support](http://www.microchip.com/support)  
Web Address:  
[www.microchip.com](http://www.microchip.com)

**Atlanta**  
Duluth, GA  
Tel: 678-957-9614  
Fax: 678-957-1455

**Austin, TX**  
Tel: 512-257-3370

**Boston**  
Westborough, MA  
Tel: 774-760-0087  
Fax: 774-760-0088

**Chicago**  
Itasca, IL  
Tel: 630-285-0071  
Fax: 630-285-0075

**Dallas**  
Addison, TX  
Tel: 972-818-7423  
Fax: 972-818-2924

**Detroit**  
Novi, MI  
Tel: 248-848-4000

**Houston, TX**  
Tel: 281-894-5983

**Indianapolis**  
Noblesville, IN  
Tel: 317-773-8323  
Fax: 317-773-5453  
Tel: 317-536-2380

**Los Angeles**  
Mission Viejo, CA  
Tel: 949-462-9523  
Fax: 949-462-9608  
Tel: 951-273-7800

**Raleigh, NC**  
Tel: 919-844-7510

**New York, NY**  
Tel: 631-435-6000

**San Jose, CA**  
Tel: 408-735-9110  
Tel: 408-436-4270

**Canada - Toronto**  
Tel: 905-695-1980  
Fax: 905-695-2078

### ASIA/PACIFIC

**Australia - Sydney**  
Tel: 61-2-9868-6733

**China - Beijing**  
Tel: 86-10-8569-7000

**China - Chengdu**  
Tel: 86-28-8665-5511

**China - Chongqing**  
Tel: 86-23-8980-9588

**China - Dongguan**  
Tel: 86-769-8702-9880

**China - Guangzhou**  
Tel: 86-20-8755-8029

**China - Hangzhou**  
Tel: 86-571-8792-8115

**China - Hong Kong SAR**  
Tel: 852-2943-5100

**China - Nanjing**  
Tel: 86-25-8473-2460

**China - Qingdao**  
Tel: 86-532-8502-7355

**China - Shanghai**  
Tel: 86-21-3326-8000

**China - Shenyang**  
Tel: 86-24-2334-2829

**China - Shenzhen**  
Tel: 86-755-8864-2200

**China - Suzhou**  
Tel: 86-186-6233-1526

**China - Wuhan**  
Tel: 86-27-5980-5300

**China - Xian**  
Tel: 86-29-8833-7252

**China - Xiamen**  
Tel: 86-592-2388138

**China - Zhuhai**  
Tel: 86-756-3210040

### ASIA/PACIFIC

**India - Bangalore**  
Tel: 91-80-3090-4444

**India - New Delhi**  
Tel: 91-11-4160-8631

**India - Pune**  
Tel: 91-20-4121-0141

**Japan - Osaka**  
Tel: 81-6-6152-7160

**Japan - Tokyo**  
Tel: 81-3-6880-3770

**Korea - Daegu**  
Tel: 82-53-744-4301

**Korea - Seoul**  
Tel: 82-2-554-7200

**Malaysia - Kuala Lumpur**  
Tel: 60-3-7651-7906

**Malaysia - Penang**  
Tel: 60-4-227-8870

**Philippines - Manila**  
Tel: 63-2-634-9065

**Singapore**  
Tel: 65-6334-8870

**Taiwan - Hsin Chu**  
Tel: 886-3-577-8366

**Taiwan - Kaohsiung**  
Tel: 886-7-213-7830

**Taiwan - Taipei**  
Tel: 886-2-2508-8600

**Thailand - Bangkok**  
Tel: 66-2-694-1351

**Vietnam - Ho Chi Minh**  
Tel: 84-28-5448-2100

### EUROPE

**Austria - Wels**  
Tel: 43-7242-2244-39  
Fax: 43-7242-2244-393

**Denmark - Copenhagen**  
Tel: 45-4450-2828  
Fax: 45-4485-2829

**Finland - Espoo**  
Tel: 358-9-4520-820

**France - Paris**  
Tel: 33-1-69-53-63-20  
Fax: 33-1-69-30-90-79

**Germany - Garching**  
Tel: 49-8931-9700

**Germany - Haan**  
Tel: 49-2129-3766400

**Germany - Heilbronn**  
Tel: 49-7131-67-3636

**Germany - Karlsruhe**  
Tel: 49-721-625370

**Germany - Munich**  
Tel: 49-89-627-144-0  
Fax: 49-89-627-144-44

**Germany - Rosenheim**  
Tel: 49-8031-354-560

**Israel - Ra'anana**  
Tel: 972-9-744-7705

**Italy - Milan**  
Tel: 39-0331-742611  
Fax: 39-0331-466781

**Italy - Padova**  
Tel: 39-049-7625286

**Netherlands - Drunen**  
Tel: 31-416-690399  
Fax: 31-416-690340

**Norway - Trondheim**  
Tel: 47-7289-7561

**Poland - Warsaw**  
Tel: 48-22-3325737

**Romania - Bucharest**  
Tel: 40-21-407-87-50

**Spain - Madrid**  
Tel: 34-91-708-08-90  
Fax: 34-91-708-08-91

**Sweden - Gothenberg**  
Tel: 46-31-704-60-40

**Sweden - Stockholm**  
Tel: 46-8-5090-4654

**UK - Wokingham**  
Tel: 44-118-921-5800  
Fax: 44-118-921-5820