

● PCB MOUNTING LEDs - Ø 5mm

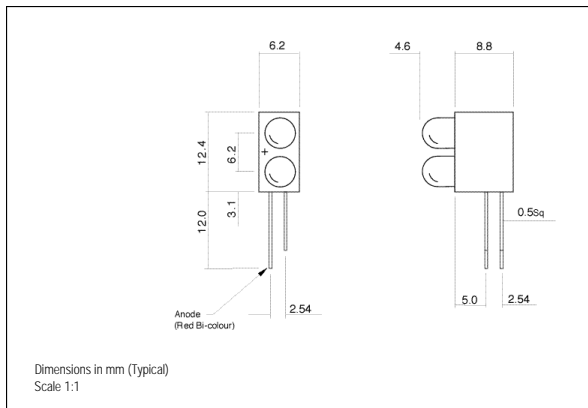

- Bi-colour and resistor models enhance potential for saving assembly time and board space
- Reverse polarity options available



110 SERIES

MLQ = 250

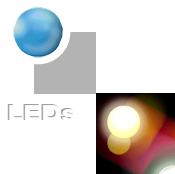

Ordering Information & Typical Technical Characteristics (Ta = 25°C)

Mean Time Between Failure = 100,000 Hours. Low Current Models 250,000 Hours. Luminous intensity figures refer to the unmodified discrete LED.

PART NUMBER	COLOUR	LENS	VOLTAGE DC Vopr	CURRENT DC Iopr	LUMINOUS INTENSITY Iv@20mA	WAVE LENGTH p	VIEWING ANGLE	OPERATING TEMP Topr	STORAGE TEMP Tstg
<b>STANDARD INTENSITY</b>									
110-505-01	Red	Coloured Diffused	2.0	2	15	625	Wide	-40 ~ +85	-40 ~ +85
110-511-01	Yellow		2.1	2	20	590			
110-514-01	Green		2.2	2	20	565			
110-505-04	Red		2.0*	20	15	625			
110-511-04	Yellow		2.1*	20	20	590			
110-514-04	Green		2.2*	20	20	565			
110-530-04	Red/Green	White Diffused	2.0/2.2*	20	30/20	625/525			
110-581-20	Red	Coloured Diffused	5	10	40@10mA	625			
110-582-20	Yellow		5	10	25@10mA	590			
110-583-20	Green		5	10	25@10mA	565			
<b>UNITS</b>			<b>Vdc</b>	<b>mA</b>	<b>mcd</b>	<b>nm</b>		<b>°C</b>	<b>°C</b>

\* = Voltage DC for 20mA product is Vf@20mA, not Vopr

Please contact our Sales office for multi-colour array part numbers.



*Making Light Work For You! Making Light Work For You! Making Light Work For You! Making Light Work For You! Making Light Work For You!*

● LEAD CROPPING OPTION, SEE PAGE 23