



# Product Change Notification

Current Date: 22-Nov-2020

## TE Connectivity

Product Change Notification: P-20-020072

PCN Date: 20-NOV-20

Customer: TTI, Inc. ( 1305175 )

Location: Maisach-gernlinden

Agreement: Agreement Unknown

TE would like to inform you of the following change(s) to the listed TE Connectivity Product. In case of any further questions about this change(s), please contact your TE Connectivity Sales Engineer. Affected part, drawing and/or specification numbers are listed on the attached sheet(s).

### General Product Description:

Implement an alternative manufacturing location - 1502 plant

### Description of Changes

We hereby inform you that TE is performing a change in the production place. This movement will not impact manufacturing technology nor current production process or staff. The related part/process approvals will be done in accordance with internal TE standards and upon request, customer requirements.

#### Other attachments:

[Alternative Manufacturing Location for PN 282080-1](#)

### Reason for Changes:

Actually the PN 282080-1 is assembled in an automatic machine on TE Connectivity, but with the volume s increase, an alternative available is assembly this product in a manual method on our supplier. This is necessary to eliminate our past due and TE will be responsible to send all parts with the same quality.

#### Estimated Dates:

<b>Last Order Date</b> (Obsolete Parts Only):	<b>First Date To Ship</b> (Changed Parts Only):
	21-DEC-2020
<b>Last Ship Date</b> (Obsolete Parts Only):	<b>Last Date for Mixed Shipments:</b> (Changed Parts Only):
	No Mixed Shipments

### Part Number(s) being Modified:

Part Number	Part Discontinued per PCN	Customer Drawing	Customer Part Number	Alias Part Number(s)	Substitute Part Number	Substitute Alias Part Number(s)	Description Of Difference
<a href="#">282080-1</a>	NO			"CM8390-000", "AMP-0-0282080-1", "2-42939-6211", "8202611296", "8202613264"			



# Product Change Notification

Current Date: 22-Nov-2020

## TE Connectivity

**Product Change Notification:** P-20-020072

**PCN Date:** 20-NOV-20

**Customer:** TTI, Inc. ( 3057778 )

**Location:** Maisach-gernlinden

**Agreement:** Agreement Unknown

TE would like to inform you of the following change(s) to the listed TE Connectivity Product. In case of any further questions about this change(s), please contact your TE Connectivity Sales Engineer. Affected part, drawing and/or specification numbers are listed on the attached sheet(s).

**General Product Description:**  
Implement an alternative manufacturing location - 1502 plant

**Description of Changes**  
We hereby inform you that TE is performing a change in the production place. This movement will not impact manufacturing technology nor current production process or staff. The related part/process approvals will be done in accordance with internal TE standards and upon request, customer requirements.  
**Other attachments:**  
[Alternative Manufacturing Location for PN 282080-1](#)

<b>Reason for Changes:</b>	
Actually the PN 282080-1 is assembled in an automatic machine on TE Connectivity, but with the volume s increase, an alternative available is assembly this product in a manual method on our supplier. This is necessary to eliminate our past due and TE will be responsible to send all parts with the same quality.	
<b>Estimated Dates:</b>	
<b>Last Order Date</b> (Obsolete Parts Only):	<b>First Date To Ship</b> (Changed Parts Only):
	21-DEC-2020
<b>Last Ship Date</b> (Obsolete Parts Only):	<b>Last Date for Mixed Shipments:</b> (Changed Parts Only):
	No Mixed Shipments

**Part Number(s) being Modified:**

Part Number	Part Discontinued per PCN	Customer Drawing	Customer Part Number	Alias Part Number(s)	Substitute Part Number	Substitute Alias Part Number(s)	Description Of Difference
<a href="#">282080-1</a>	NO		TYC282080-1	"CM8390-000", "AMP-0-0282080-1", "2-42939-6211", "8202611296", "8202613264"			

# Alternative Manufacturing Location PN 282080-1



Braganca Plant

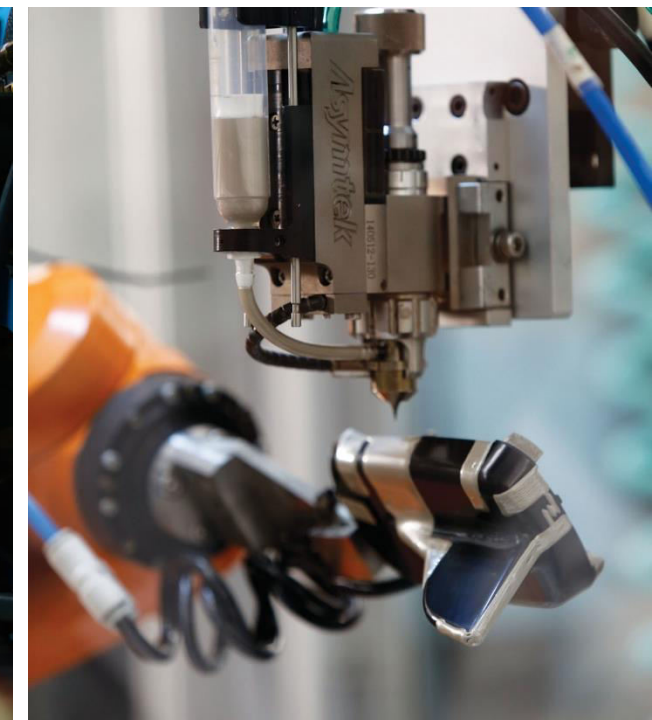

EVERY CONNECTION COUNTS

# Description

We hereby inform you that TE is performing a change in the production place.

This movement will not impact manufacturing technology nor current production process or staff. The related part/process approvals will be done in accordance with internal TE standards and upon request, customer requirements.

Actually the PN 282080-1 is assembled in an automatic machine on TE Connectivity, but with the volume's increase, an alternative available is assembly this product in a manual method on our supplier.

This is necessary to eliminate our past due and TE will be responsible to send all parts with the same quality.

# Strategy

- Process / Product validation
  - QIP [Quality Inspection Plan] results evaluation.
  - PPAP will be updated and resubmitted.
  - (1) All parts manufactured on automatic assembly are marked with pneumatic puncture.
  - (2) All parts manufactured on manual assembly will be revised 100% and marked with a blue point.

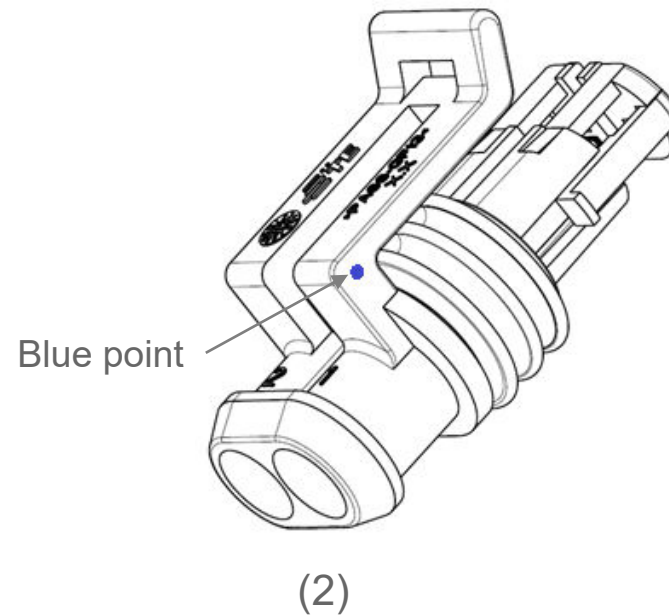
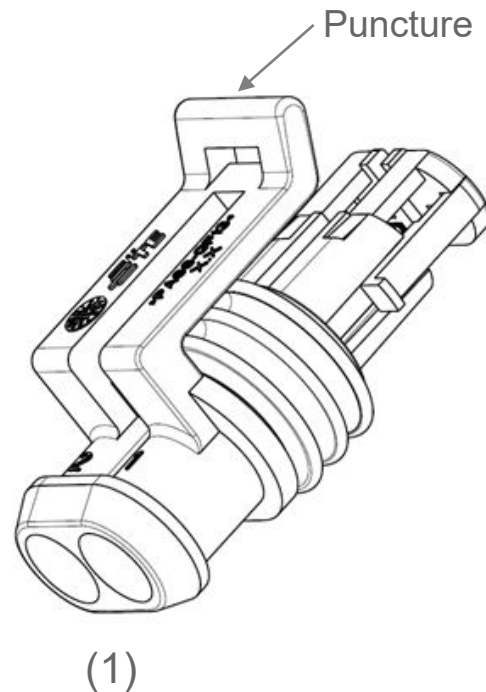

---

**ANY  
CONNECTION  
CAN CHANGE  
THE WORLD**

---

EVERY CONNECTION COUNTS

