

INSTALLATION GUIDE AND TERMINAL BLOCK SPECIFICATIONS

NI PXIe-4353 and TC-4353

Français Deutsch 日本語 한국어 简体中文

ni.com/manuals

NI SC Express is a family of PXI Express modules with integrated data acquisition and signal conditioning. These devices offer increased speed, accuracy, and synchronization features that are well suited for high-density sensor measurement and signal-conditioning systems. The TC-4353 rack-mount terminal block accessories provides thermocouple plug-in terminal connectivity.

This guide describes how to install and configure the NI PXIe-4353 module and TC-4353 terminal block, thermocouple connector signals, and verify that the system is working properly. Current versions of NI documents are available at ni.com/manuals.

The NI PXIe-4353 is a high-accuracy thermocouple input module that supports up to 32 thermocouple inputs and has 8 cold-junction compensation (CJC) channels for improved CJC accuracy. The TC-4353 terminal block has eight thermistors that provide CJC for thermocouples.

The TC-4353 terminal block is designed for use with the following module as specified:

NI PXIe-4353 ±80 mV maximum voltage measurement range



Caution Do not supply hazardous voltages ($>30 V_{\text{rms}}/42.4 V_{\text{pk}}/60 \text{ VDC}$) to the TC-4353 terminal block.



Note Refer to the *NI PXIe-4353 Specifications* document for additional voltage and safety information.

The keying of this terminal block prevents it from connecting to other modules that could be damaged by the voltage present on the terminal block. However, you should only use this terminal block with its supported modules.

Contents

What You Need to Get Started	3
Installation	3
Step 1. Install the Software	3
Step 2. Unpack and Install the Module	4
Step 3. Install the Terminal Block, Chassis, and Cables	5
Step 4. Confirm NI SC Express Module Recognition	9
Step 5. Run Test Panels	10
Step 6. Take an NI-DAQmx Measurement	10
NI-DAQmx Channels and Tasks	10
Configure a Task Using the DAQ Assistant from MAX	10
Step 7. Use Your NI SC Express 4353 in an Application	11
Programming Examples	11
Removal	12
Step 1. Remove the Terminal Block and Cables	12
Step 2. Remove the Module	12
Create a Simulated Device	13
Cold-Junction Compensation	14
Minimizing Thermal Gradients	15
Calibrate the Module and Terminal Block	15
More Information	16
Troubleshooting	16
Specifications	16
Calibration	16
Electrical	16
Mechanical	18
Physical	18
Environmental Specifications	18
Operating Environment	18
Storage Environment	19
Shock and Vibration	19
Safety Voltages	19
Safety Standards	20
Electromagnetic Compatibility	20
CE Compliance	20
Online Product Certification	21
Environmental Management	21
Worldwide Technical Support	21

What You Need to Get Started

To set up and use the TC-4353 rack-mount terminal block with the NI PXIe-4353 module, you need the following items:

- Hardware
 - TC-4353 rack-mount terminal block
 - NI PXIe-4353 module
 - PXIe chassis
 - 19 in. rack to accommodate the TC-4353 and NI PXIe-4353
 - Four 10-32 screws of a length suitable for your application (not supplied by NI)
 - SH96-96-1 cable and included standoffs
 - Rack-mount kit (as required for your application)
 - Shielded thermocouple wire and thermocouple miniconnectors as required for your application
- Tools
 - Phillips-head and flathead screwdrivers as required by your application
 - Wire cutter
 - Wire insulation stripper
- Documentation
 - *NI PXIe-4353 and TC-4353 Installation Guide and Terminal Block Specifications*
 - *Read Me First: Safety and Electromagnetic Compatibility*
 - *NI PXIe-4353 User Manual*
 - PXIe chassis user manual

You can download needed documents from ni.com/manuals.

Installation

Step 1. Install the Software



Note You must be an administrator to install NI software and devices on your computer.

Before installing the NI SC Express hardware, make sure the following are installed in the order indicated:

1. Your application software, such as LabVIEW, LabWindows™/CVI™, or .NET.
2. NI-DAQmx 9.6 or later.



Note When installing NI application software, such as NI LabVIEW, refer to the *NI-DAQmx Readme* on the software disc for supported software versions. Back up any applications before upgrading software or modifying the application.



Tip Using an NI-DAQmx simulated device, you can test NI-DAQmx applications without installing hardware. Refer to the [Create a Simulated Device](#) section for instructions for creating NI-DAQmx simulated devices.

Step 2. Unpack and Install the Module

Remove the packaging and inspect the module. Contact NI if the module is damaged. Do not install a damaged module.



Caution The module is static sensitive. Always properly ground yourself and the equipment when handling or connecting to the module.

Complete the following steps to install the NI SC Express module while referring to Figures 1 and 2:

1. Power off the PXI Express chassis. Refer to the chassis manual for chassis installation and configuration instructions.



Caution Refer to the *Read Me First: Safety and Electromagnetic Compatibility*, included with your module, before connecting or disconnecting signal wires.

2. Identify a supported PXI Express slot in the chassis. NI SC Express devices can be placed only in PXI Express Peripheral slots, PXI Express Hybrid Peripheral slots, and PXI Express System Timing slots. Refer to the chassis documentation for details.

Figure 1. Symbols for PXI Express/PXI Express Hybrid/PXI Slots

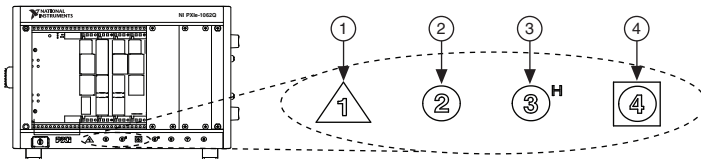

1	PXI Express System Controller Slot	3	PXI Express Hybrid Peripheral Slot
2	PXI Peripheral Slot	4	PXI Express System Timing Slot

3. Remove the filler panel and touch any metal part of the chassis to discharge static electricity.
4. Place the module edges into the module guides at the top and bottom of the slot.



Caution When installing the module, make sure both edges are positioned inside the guides and that the module components do not come into contact with adjacent modules.

5. Slide the module along the guides until it reaches the rear connector, then seat the module by pushing the front panel until it is flush with the front panel of the chassis.
6. Secure the module to the chassis using the front-panel captive screws, shown in Figure 2. Tighten the screws to $0.31 \text{ N} \cdot \text{m}$ ($2.7 \text{ lb} \cdot \text{in.}$).

Figure 2. Installing NI SC Express Modules

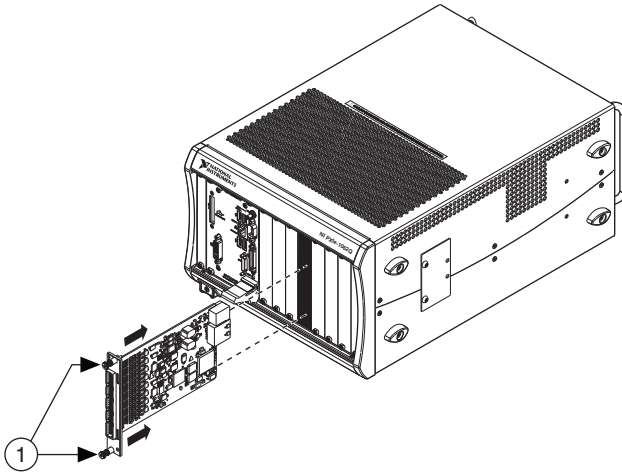

1 Captive Screws

Step 3. Install the Terminal Block, Chassis, and Cables



Caution Refer to the *Read Me First: Safety and Electromagnetic Compatibility* document before removing equipment covers or connecting or disconnecting any signal wires.



Caution Do not supply hazardous voltages ($>30 \text{ V}_{\text{rms}}/42.4 \text{ V}_{\text{pk}}/60 \text{ VDC}$) to the terminal block.



Note The chassis can be powered on or off when installing the terminal block.



Caution To ensure the EMC performance specified for the connected NI PXIe-4353 module, operate this product only with shielded thermocouple wires.

To install the rack-mount terminal block into the rack, complete the following steps while referring to Figure 3.

1. Mount the TC-4353 in the desired position by installing and tightening the four rack-mounting screws.

If the chassis is not already installed in the rack, complete the following steps:

1. Attach the PXIe chassis rack-mount hardware to the NI PXIe chassis according to the rack-mount hardware instructions.
2. Mount the PXIe chassis in the rack in the desired position.

Figure 3. TC-4353 Installation and Front Connections

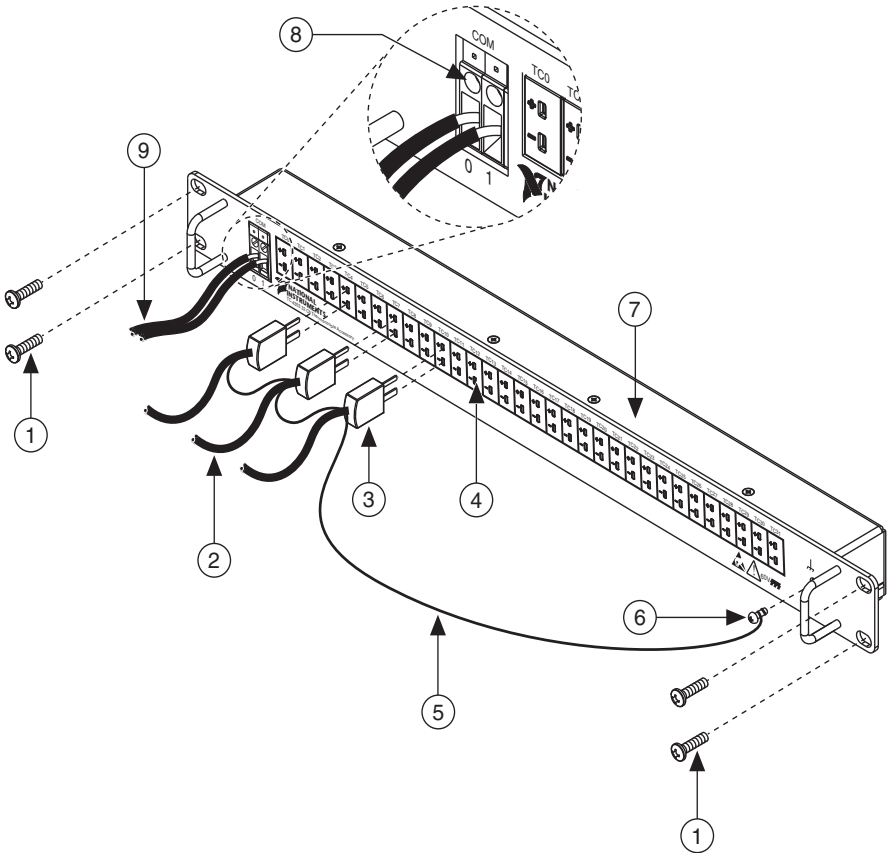

- | | |
|---|-------------------------------------|
| 1 Rack-Mounting Screws (4) | 6 Chassis Ground Screw |
| 2 To Thermocouple Sensors | 7 TC-4353 Rack-Mount Terminal Block |
| 3 Thermocouple Miniconnector | 8 COM Terminals |
| 4 Thermocouple Miniconnector Receptacle | 9 To COM |
| 5 Shield Drain Wire | |

To install the cables, complete the following steps while referring to Figures 3 and 4.



Note For safety purposes and to prevent damage to equipment when high voltages are present, the SH96-96-1 cable is keyed to prevent connection between incompatible terminal blocks, modules, and/or cables.

1. Connect the shield drain wire of the shielded thermocouple wire to the chassis ground screw, shown daisy chained in Figure 3. Make the shield drain wire as short as practical for your application.
2. Connect the COM wires to the COM terminals.
3. Connect the thermocouple miniconnectors to the appropriate thermocouple miniconnector receptacles.
4. Screw the two standoffs into the NI PXIe-4353 module. Tighten the standoffs to $0.90 \text{ N} \cdot \text{m}$ ($8.0 \text{ lb} \cdot \text{in.}$).
5. Connect the male end of the SH96-96-1 cable to the TC-4353 and tighten the two jack screws to $0.90 \text{ N} \cdot \text{m}$ ($8.0 \text{ lb} \cdot \text{in.}$).
6. Connect the female end of the SH96-96-1 cable to the NI PXIe-4353 and tighten the two jack screws to $0.90 \text{ N} \cdot \text{m}$ ($8.0 \text{ lb} \cdot \text{in.}$).

For information about CJC and accuracy considerations refer to the [Cold-Junction Compensation](#) section.



Note For information about sensors, go to ni.com/sensors.

Figure 4. SH96-96-1 Cable and Standoff Installation

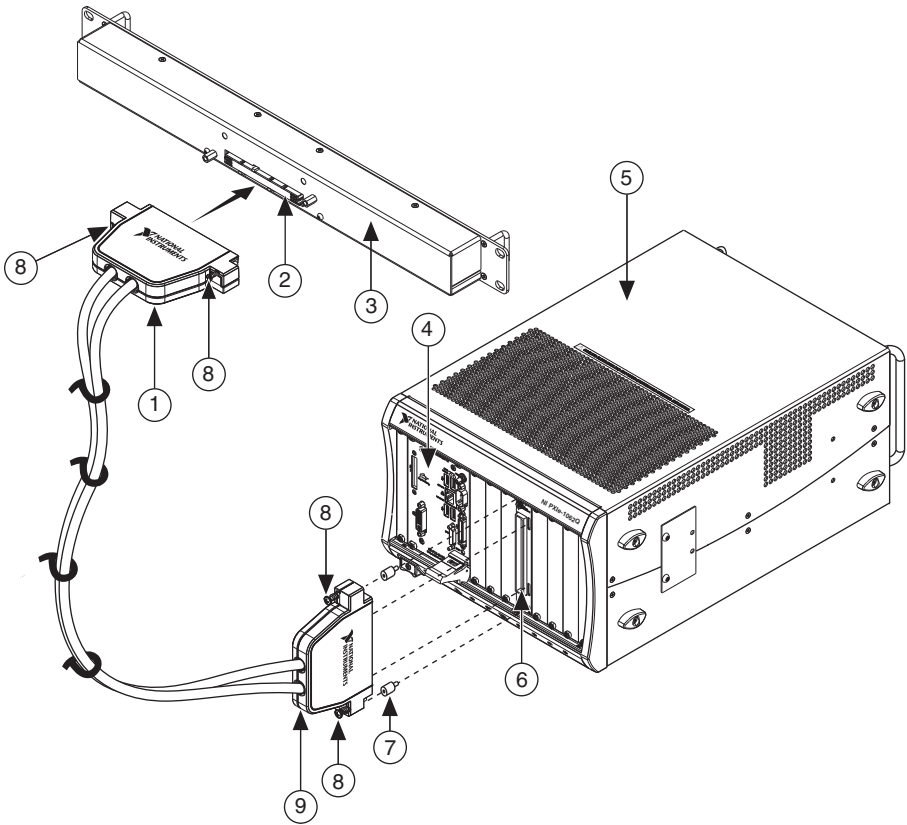

-
- | | |
|--|---|
| 1 SH96-96-1 Cable TC-4353 Connector Plug | 6 NI PXIe-4353 Module |
| 2 TC-4353 Connector Receptacle | 7 Standoffs (2) |
| 3 TC-4353 Rack-Mount Terminal Block | 8 Jack Screws (4x) |
| 4 PXI Controller | 9 SH96-96-1 Cable NI PXIe-4353 Connector Plug |
| 5 PXIe Chassis | |
-

7. Power on the PXIe chassis if it is powered off.

Step 4. Confirm NI SC Express Module Recognition

To confirm module recognition, complete the following steps:



Note Make sure you are using the most recent version of NI-DAQmx. If you are using an older version of the driver software, the NI SC Express terminal block may work only in basic functionality mode. Unsupported terminal blocks appear in Measurement & Automation Explorer (MAX) with an X next to them.

1. Launch MAX.



2. Expand **Devices and Interfaces»NI-DAQmx Devices** to confirm that MAX detects the module and terminal block. The terminal block should appear beneath its associated module. If your module or terminal block is not listed, press <F5> to refresh MAX. If the module is still not recognized, go to ni.com/support/daqmx.

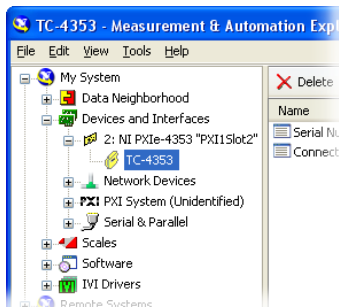

Tip Using an NI-DAQmx simulated device, you can test NI-DAQmx applications without installing hardware. Refer to the [Create a Simulated Device](#) section for instructions for creating NI-DAQmx simulated devices.

3. Right-click the module name and select **Self-Test**. When the self-test completes, a verification message appears. If an error occurs, refer to ni.com/support/daqmx.

For information about sensors, go to ni.com/sensors.

Step 5. Run Test Panels

1. In MAX, expand **Devices and Interfaces»NI-DAQmx Devices**.
2. Right-click the device, and select **Test Panels**.

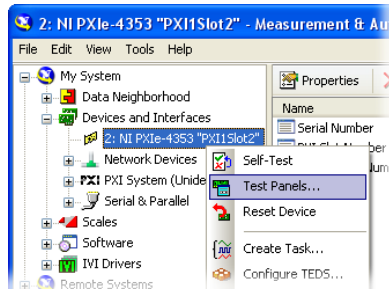

3. Click **Start** to test device functions, or **Help** for operating instructions.

To troubleshoot errors, refer to the *NI-DAQmx Help*, or go to ni.com/support.

Step 6. Take an NI-DAQmx Measurement

NI-DAQmx Channels and Tasks

Refer to the *NI-DAQmx Help* for complete information about channels and tasks.

Use the DAQ Assistant to configure virtual channels and tasks in MAX or in your application.

Configure a Task Using the DAQ Assistant from MAX

Complete the following steps to create a task using the DAQ Assistant in MAX:

1. In MAX, right-click **Data Neighborhood** and select **Create New** to open the DAQ Assistant.
2. Select **NI-DAQmx Task** and click **Next**.
3. Select **Acquire Signals**.



Note The NI PXIe-4353 cannot generate signals.

4. Select **Analog Input** and the measurement type, such as **Temperature»Thermocouple** or **Voltage**.
5. Select the physical channel(s) to use and click **Next**.
6. Name the task and click **Finish**.
7. Configure the individual channel settings. Each physical channel you assign to a task receives a virtual channel name. To modify the input range or other settings, select the channel. Click **Details** for physical channel information. Configure the timing and triggering for your task. Click **Run**.

Step 7. Use Your NI SC Express 4353 in an Application

For NI software version compatibility, refer to the NI-DAQmx Readme, available from **Start»All Programs»National Instruments»NI-DAQmx**.

To get started with data acquisition in your application software, refer to the tutorials listed in Table 1.

Table 1. DAQ Assistant Tutorial Locations

Application	Tutorial Location
LabVIEW	Go to Help»Search the LabVIEW Help . Next, go to Getting Started with LabVIEW»Getting Started with DAQ»Taking an NI-DAQmx Measurement in LabVIEW .
LabWindows/CVI	Go to Help»Contents . Next, go to Using LabWindows/CVI»Data Acquisition»Taking an NI-DAQmx Measurement in LabWindows/CVI .
Measurement Studio	Go to NI Measurement Studio Help»Getting Started with the Measurement Studio Class Libraries»Measurement Studio Walkthroughs»Walkthrough: Creating a Measurement Studio NI-DAQmx Application .
LabVIEW SignalExpress*	Go to Help»Taking an NI-DAQmx Measurement in SignalExpress .
* LabVIEW SignalExpress, an easy-to-use configuration-based tool for data logging applications, is at Start»All Programs»National Instruments»LabVIEW SignalExpress .	

Programming Examples

NI-DAQmx includes example programs to help you get started developing an application. LabVIEW and CVI examples are located at **Help»Find Examples** in your application software. Text-based code examples are located at **All Programs»National Instruments»NI-DAQ»Text-Based Code Support»ANSI C Examples**. Modify example code and save it in an application, or use examples to develop a new application or add example code to an existing application.

For other examples, go to ni.com/info and enter the Info Code `daqmxexp`. For additional examples, refer to zone.ni.com.

Removal

Step 1. Remove the Terminal Block and Cables

To remove the TC-4353 and NI PXIe-4353, complete the following steps while referring to Figures 3 and 4:



Note The chassis can be powered on or off when removing the terminal block.

1. Remove the thermocouple miniconnectors, shield drain wires, and COM wires from the terminal block.
2. Loosen the four jack screws and remove the SH96-96-1 cable from the terminal block and the module.



Note If required for your application, remove the two standoffs from the module.

3. While supporting the terminal block, remove the four rack-mounting screws.
4. Remove the terminal block from the rack.
5. Store the terminal block in an antistatic protective bag.

Step 2. Remove the Module



Caution Do *not* remove a module with the power on. Doing so can damage the module.

1. Make sure that the chassis is powered off before removing the module.
2. Loosen the captive screws on the top and bottom of the module.



Caution Do *not* pull the front panel to remove the module. Doing so may cause module components to come into contact with adjacent modules, causing damage to the modules.

3. Pull the captive screws to unseat the module and slowly slide the module along the guides, as shown in Figure 5.
4. Replace the filler panel in the empty slot.
5. Store the module in an antistatic protective bag.

Figure 5. Removing NI SC Express Modules

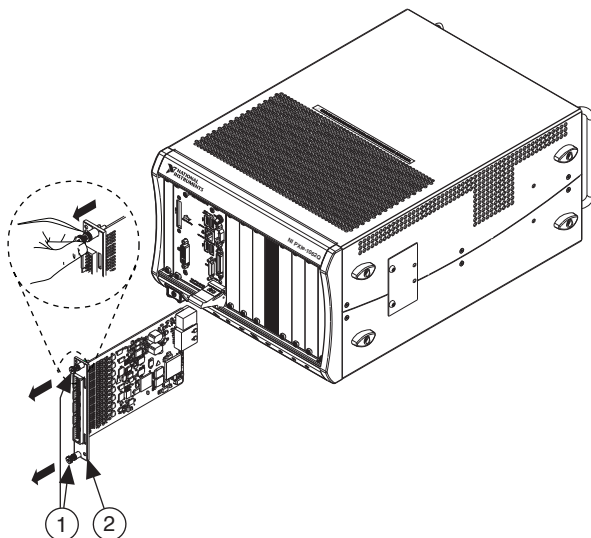

1 Captive Screws (Use to remove modules.)

2 Front Panel (Do not use to remove modules.)

Create a Simulated Device

To run examples without the hardware installed, use an NI-DAQmx simulated device. To create a simulated device in MAX:

1. Launch MAX.
2. Right-click **Devices and Interfaces»Create New**.
3. From the dialog, select **Simulated NI-DAQmx Device or Modular Instrument**.
4. Type 4353 in the text box at the top of the window.
5. Select the device from the list provided.
6. Click **OK**.

Cold-Junction Compensation

Cold-junction compensation is the process of measuring the temperature of the junction for the thermocouple and applying a representative compensating voltage to the voltage measured by the thermocouple channel. The accuracy of the cold-junction temperature measurement is a key part of the accuracy of the overall thermocouple temperature measurement. The TC-4353 is carefully designed to ensure high-accuracy cold-junction temperature measurements, under a variety of conditions; however, care must be taken to ensure the best possible accuracy. Refer to the [Minimizing Thermal Gradients](#) section for guidelines to minimize thermal gradients that could impact the CJC accuracy. Refer to the [Specifications](#) section for the CJC accuracy specifications.

The TC-4353 contains eight thermistors that are used to measure the temperature of the adjacent thermocouple junctions for the CJC that is performed when computing the thermocouple temperature measurement. These eight thermistors are measured using the CJC channels on the NI PXIe-4353 module. Each thermistor measures the CJC temperature for a subset of associated thermocouple channels. Figure 6 shows the CJC grouping locations. The dashed lines indicate the channel to CJC associations found in Table 2. NI-DAQmx automatically associates the correct thermistor with the thermocouple measurements when you use the **Thermocouple Channel-Type** and select **built-in** for the CJC source.

Figure 6. TC-4353 CJC Grouping Locations

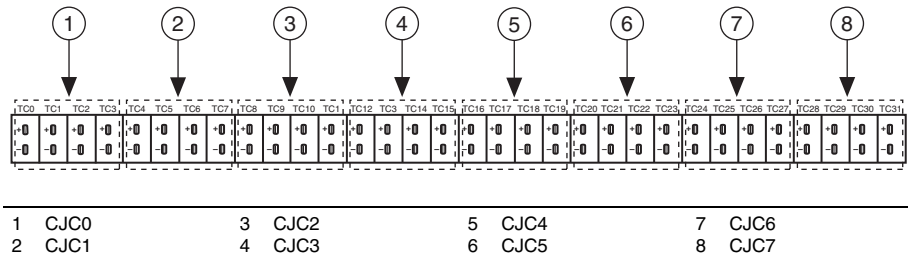

Table 2. CJC to Thermocouple Channels Associations

CJC	Associated Thermocouples
CJC0	TC <0..3>
CJC1	TC <4..7>
CJC2	TC <8..11>
CJC3	TC <12..15>

CJC	Associated Thermocouples
CJC4	TC <16..19>
CJC5	TC <20..23>
CJC6	TC <24..27>
CJC7	TC <28..31>

Minimizing Thermal Gradients

Thermal gradients can be caused by changes in the ambient air temperature near the terminal block, heat sources from other devices near the terminal block, or by the thermocouple wire if it conducts heat to or away from the terminal junctions. For optimal CJC accuracy performance, ensure that changes in ambient temperature and temperature gradients near the terminal block are kept to a minimum. Follow these guidelines to minimize thermal gradients that could impact the CJC accuracy:

- Use the smallest gauge thermocouple wire suitable for the application. Smaller wire transfers less heat to or from the terminal junction.
- Run thermocouple wiring together near the terminal block to keep the wires at the same temperature.
- Avoid running thermocouple wires near hot or cold objects.
- If you connect any extension wires to thermocouple wires, use wires made of the same conductive material as the thermocouple wires.
- Minimize adjacent heat sources and air flow across the terminal block.
- Keep the ambient temperature as stable as possible.
- Keep the terminal block, module, and chassis in a stable and consistent orientation.
- Install the PXIe filler panels in any unused slots.
- When stacking the system, avoid stacking the terminal block above a heat source as heat rises and can introduce error.
- Allow the thermal gradients to settle after a change in system power or in ambient temperature. A change in system power can happen when the system powers on. Refer to the warm-up time in the *NI PXIe-4353 Specifications* for more information.
- Replace, clean, or remove the fan filters in the PXIe chassis regularly to ensure proper system cooling.

Calibrate the Module and Terminal Block

You can download available external calibration documents from ni.com/calibration by clicking **Manual Calibration Procedures**. For external calibration of products not listed there, Basic Calibration Service or Detailed Calibration Service is recommended. You can get information about both of these calibration services at ni.com/calibration. NI recommends performing an external calibration once a year.

More Information

After you install NI-DAQmx, the NI-DAQmx documentation is available from **Start» All Programs»National Instruments»NI-DAQ**. Additional resources are online at ni.com/gettingstarted.

You can access online device documentation by right-clicking your module in MAX and selecting **Help»Online Device Documentation**. A browser window opens to ni.com/manuals with the results of a search for relevant documents. If you do not have Web access, documents for supported modules are included on the NI-DAQmx disc.

Troubleshooting

- Go to ni.com/support/install or ni.com/kb.
- If you need to return your National Instruments hardware for repair or device calibration, go to ni.com/info and enter `rdsean` to start the Return Merchandise Authorization (RMA) process.

Specifications



Note NI PXIe-4353 module specifications are located in the *NI PXIe-4353 Specifications* document.

All specifications are typical for the range of 0 °C to 55 °C unless otherwise specified.

Calibration

Calibration interval 1 year

Electrical

Cold-junction sensors

Sensor type..... NTC thermistor, 10 k Ω nominal

Steinhart-Hart scaling coefficients¹

A..... 1.1288643×10^{-3}

B..... 2.3414908×10^{-4}

C..... 8.7706554×10^{-8}

¹ Refer to the software documentation for details about scaling the thermistor readings.

CJC accuracy¹

Terminal Block	Typical*		Maximum*	
	23 °C ±5 °C	0 °C to 55 °C	23 °C ±5 °C	0 °C to 55 °C
TC-4353, Configuration A [†]	0.18 °C	0.25 °C	0.25 °C	0.37 °C
TC-4353, Configuration B [‡]	—	—	0.46 °C	0.51 °C
TC-4353, Configuration C ^{**}	—	—	1.90 °C	2.02 °C

* For graphs that combine CJC Accuracy with Voltage Measurement Accuracy to derive overall thermocouple measurement accuracy, go to ni.com/info and use Info Code PXIE4353CALCULATOR.

[†] Configuration A represents a TC-4353 deployed into a thermally isolated setup.

[‡] Configuration B represents a TC-4353 that is mounted below any heat sources in the rack and is protected from airflow by a physical barrier.

** Configuration C represents a TC-4353 that has not been protected from heat sources.

Note: For example configurations go to ni.com/info and use Info Code TC4353CONFIGURATIONS.

Input voltage range Refer to the *NI PXIe-4353 Specifications* document.

¹ This includes the combined effects of the thermistor accuracy and the temperature difference between the screw terminal and its associated thermistor. This represents performance for wire gauges of 20 AWG and smaller.

Mechanical

Screw terminal wire gauge 10 AWG to 24 AWG

Connectors mini-thermocouple

Physical

Figure 7. TC-4353 Dimensions

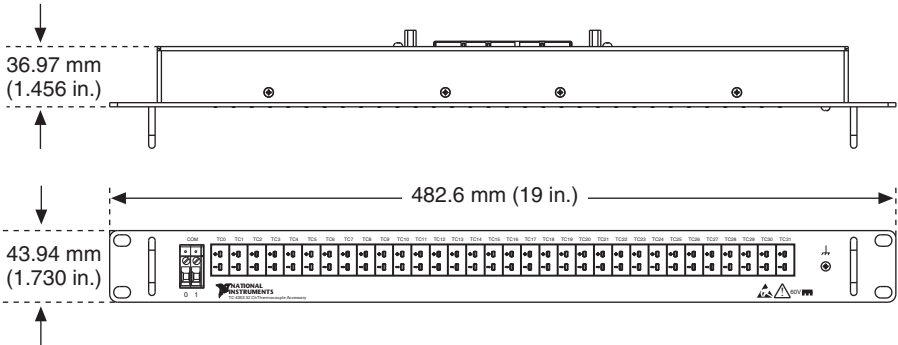

Weight 825 g (29.1 oz)

Environmental Specifications

Maximum altitude 2,000 m (800 mbar)

Pollution Degree 2

Indoor use only.

Operating Environment

Ambient temperature range 0 °C to 55 °C

(Tested in accordance with IEC-60068-2-1 and IEC-60068-2-2. Meets MIL-PRF-28800F Class 3 low temperature limit and MIL-PRF-28800F Class 2 high temperature limit.)

Relative humidity range 10% to 90%, noncondensing

(Tested in accordance with IEC-60068-2-56.)

Storage Environment

Ambient temperature range	-40 °C to 71 °C (Tested in accordance with IEC-60068-2-1 and IEC-60068-2-2. Meets MIL-PRF-28800F Class 3 limits.)
Relative humidity range.....	5% to 95%, noncondensing (Tested in accordance with IEC-60068-2-56.)

Shock and Vibration

Operating shock	30 g peak, half-sine, 11 ms pulse (Tested in accordance with IEC-60068-2-27. Meets MIL-PRF-28800F Class 2 limits.)
Random vibration	
Operating	5 Hz to 500 Hz, 0.3 g _{rms}
Non-operating	5 Hz to 500 Hz, 2.4 g _{rms} (Tested in accordance with IEC-60068-2-64. Non-operating test profile exceeds the requirements of MIL-PRF-28800F, Class 3.)

Safety Voltages

Isolation (TC-4353)

Channel-to-channel.....	None
Channel-to-earth ground.....	60 VDC, Measurement Category I

Measurement Category I is for measurements performed on circuits not directly connected to the electrical distribution system referred to as MAINS voltage. MAINS is a hazardous live electrical supply system that powers equipment. This category is for measurements of voltages from specially protected secondary circuits. Such voltage measurements include signal levels, special equipment, limited-energy parts of equipment, circuits powered by regulated low-voltage sources, and electronics.



Caution Do *not* connect the TC-4353 to signals or use for measurements within Measurement Categories II, III or IV.



Caution The protection provided by the TC-4353 can be impaired if it is used in a manner not described in this document.



Caution Refer to the *NI PXIe-4353 Specifications* document for maximum voltage limits. When used with the TC-4353, the isolation voltage is 60 V max from channel or COM to earth ground.

Safety Standards

This product meets the requirements of the following standards of safety for electrical equipment for measurement, control, and laboratory use:

- IEC 61010-1, EN 61010-1
- UL 61010-1, CSA 61010-1

Electromagnetic Compatibility

This product meets the requirements of the following EMC standards for electrical equipment for measurement, control, and laboratory use:

- EN 61326-1 (IEC 61326-1): Class A emissions; Basic immunity
- EN 55011 (CISPR 11): Group 1, Class A emissions
- EN 55022 (CISPR 22): Class A emissions
- EN 55024 (CISPR 24): Immunity
- AS/NZS CISPR 11: Group 1, Class A emissions
- AS/NZS CISPR 22: Class A emissions
- FCC 47 CFR Part 15B: Class A emissions
- ICES-001: Class A emissions



Caution For EMC compliance, operate this product with shielded cables and accessories.



Note In the United States (per FCC 47 CFR), Class A equipment is intended for use in commercial, light-industrial, and heavy-industrial locations. In Europe, Canada, Australia and New Zealand (per CISPR 11) Class A equipment is intended for use only in heavy-industrial locations.



Note Group 1 equipment (per CISPR 11) is any industrial, scientific, or medical equipment that does not intentionally generate radio frequency energy for the treatment of material or inspection/analysis purposes.



Note For EMC declarations and certifications, and additional information, refer to the [Online Product Certification](#) section.

CE Compliance

This product meets the essential requirements of applicable European Directives as follows:

- 2006/95/EC; Low-Voltage Directive (safety)
- 2004/108/EC; Electromagnetic Compatibility Directive (EMC)

Online Product Certification

Refer to the product Declaration of Conformity (DoC) for additional regulatory compliance information. To obtain product certifications and the DoC for this product, visit ni.com/certification, search by model number or product line, and click the appropriate link in the Certification column.

Environmental Management

NI is committed to designing and manufacturing products in an environmentally responsible manner. NI recognizes that eliminating certain hazardous substances from our products is beneficial to the environment and to NI customers.

For additional environmental information, refer to the *NI and the Environment* Web page at ni.com/environment. This page contains the environmental regulations and directives with which NI complies, as well as other environmental information not included in this document.

Waste Electrical and Electronic Equipment (WEEE)



EU Customers At the end of the product life cycle, all products *must* be sent to a WEEE recycling center. For more information about WEEE recycling centers, National Instruments WEEE initiatives, and compliance with WEEE Directive 2002/96/EC on Waste and Electronic Equipment, visit ni.com/environment/weee.

电子信息产品污染控制管理办法（中国 RoHS）



中国客户 National Instruments 符合中国电子信息产品中限制使用某些有害物质指令 (RoHS)。关于 National Instruments 中国 RoHS 合规性信息，请登录 ni.com/environment/rohs_china。(For information about China RoHS compliance, go to ni.com/environment/rohs_china.)

Worldwide Technical Support

The National Instruments Web site is your complete resource for technical support. At ni.com/support you have access to everything from troubleshooting and application development self-help resources to email and phone assistance from NI Application Engineers.

National Instruments corporate headquarters is located at 11500 North Mopac Expressway, Austin, Texas, 78759-3504. National Instruments also has offices located around the world to help address your support needs. For telephone support in the United States, create your service request at ni.com/support and follow the calling instructions or dial 512 795 8248. For telephone support outside the United States, visit the Worldwide Offices section of ni.com/niglobal to access the branch office Web sites, which provide up-to-date contact information, support phone numbers, email addresses, and current events.

CVI, LabVIEW, National Instruments, NI, ni.com, the National Instruments corporate logo, and the Eagle logo are trademarks of National Instruments Corporation. Refer to the *Trademark Information* at ni.com/trademarks for other National Instruments trademarks. The mark LabWindows is used under a license from Microsoft Corporation. Windows is a registered trademark of Microsoft Corporation in the United States and other countries. Other product and company names mentioned herein are trademarks or trade names of their respective companies. For patents covering National Instruments products/technology, refer to the appropriate location: **Help»Patents** in your software, the `patents.txt` file on your media, or the *National Instruments Patents Notice* at ni.com/patents. Refer to the *Export Compliance Information* at ni.com/legal/export-compliance for the National Instruments global trade compliance policy and how to obtain relevant HTS codes, ECCNs, and other import/export data.

© 2012 National Instruments. All rights reserved.