

**PROPER USE GUIDELINES**

Cumulative Trauma Disorders can result from the prolonged use of manually powered hand tools. Hand tools are intended for occasional use and low volume applications. A wide selection of powered application equipment for extended-use, production operations is available.

DIE SET PART NUMBER	CONNECTOR TYPES	CABLE SIZES
9-1478242-0	BNC, FME, N TYPE, TNC, UHF	RG 55, 58, 59, 62, 140, 141, 142, 210, 223, 400 URM 43, 70, 73, 76, 90, 301 Belden 9907 PSF 1/3M TM 3304 BT 2002 SDTV NEK 23795

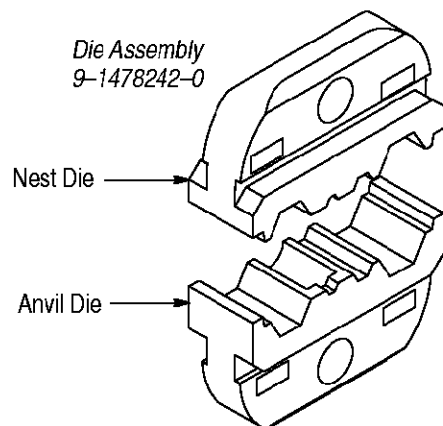
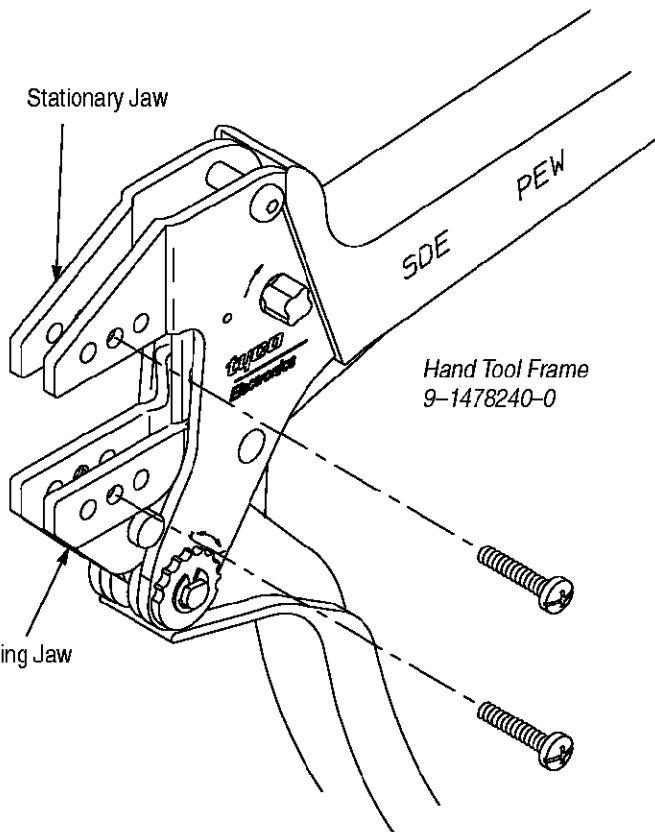

Figure 1

**1. INTRODUCTION**

This instruction sheet covers the use and maintenance of GREENPAR Crimping Die Assembly 9-1478242-0 used in Hand Tool Frame 9-1478240-0. The dies crimp various plug connectors onto coaxial cable. See Figure 1 for a list of the connector types and cable sizes each die set can crimp.

Reason for revision may be found in Section 8, REVISION SUMMARY.

**NOTE** All dimensions are in millimeters [with inches in brackets]. Figures are drawn for identification only and are not drawn to scale.

**2. DESCRIPTION** (Figure 1)

Each die assembly consists of a nest die and an anvil die. When closed, the dies form four crimping chambers which crimp the center contact and ferrule

of the connector onto the coaxial cable. Each die is held in the tool by a single screw.

**3. DIE INSTALLATION**

1. Close the tool handles until the ratchet releases and then allow them to open fully.
2. See Figure 1 for normal orientation of the dies. Insert the dies inside the tool jaws and align the retaining screw holes.
3. Thread the retaining screws into the holes and carefully close the tool handles. Tighten the screws with the appropriate hex wrench.

**4. CRIMPING PROCEDURE** (Figure 2)

**4.1. Center Contact**

1. Prepare the connector and the cable according to the instructions packaged with the connector.

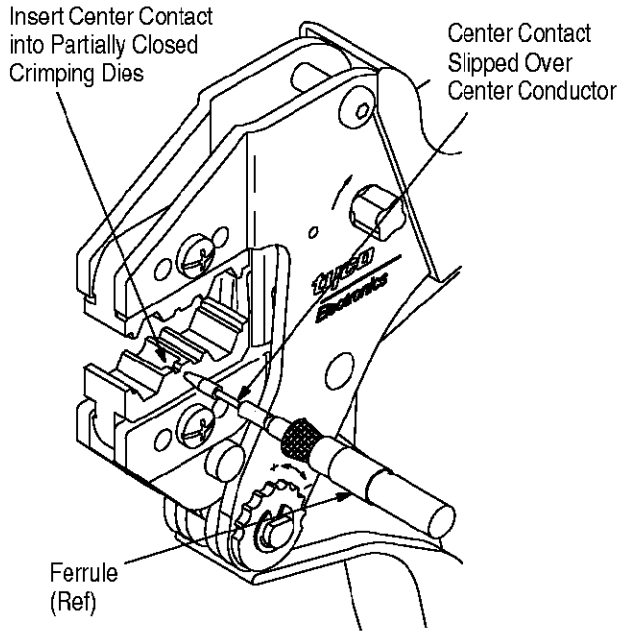

Figure 2

2. Slide the center contact onto the center conductor of the cable; then insert the contact assembly into the center contact crimp section of the die.

**NOTE** Make sure that the flange on the end of the center contact butts against the crimping die. See Figure 3.

3. Crimp the center contact by holding the cable in place; then close the tool handles until the ratchet releases.

Flange on End of Center Contact Butts Against Die

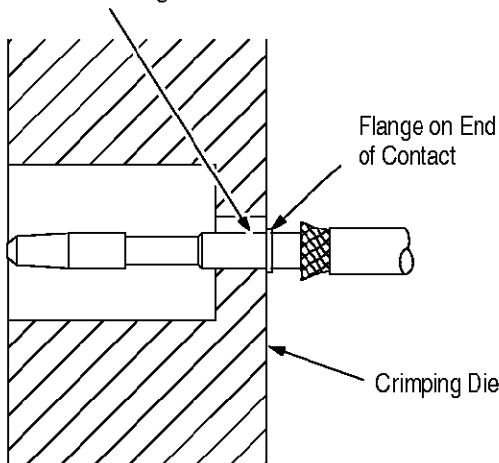

Figure 3

**4.2. Ferrule**

1. Insert the crimped center contact into the connector body until the cable dielectric butts against the dielectric inside of the connector body. The flared braid will then fit around the support sleeve of the connector body.
2. Slide the ferrule forward over the braid until the ferrule butts against the shoulder on the connector body.
3. Place the ferrule on the anvil of the die assembly so that the shoulder on the connector body is butted against the die. See Figure 4.
4. Holding the assembly in place, close the tool handles until the ratchet releases.

**Crimping Ferrule**

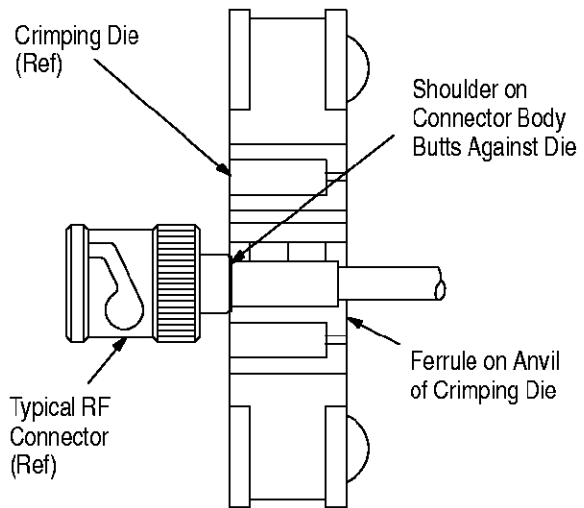

Figure 4

**5. INSPECTION**

**5.1. Visual Inspection**

Inspection of the crimping dies should be made on a regular basis to ensure that they have not become worn or damaged. Inspect the crimp sections for flattened, chipped, worn, or broken areas. If damage or abnormal wear is evident, the dies must be replaced. Refer to Section 7, PARTS REPLACEMENT.

**5.2. Measuring Die Opening**

The die assembly will perform correctly as long as: (1) the product specified is correct for the application, (2) the specific die assembly is used, (3) the die assembly has been measured to ensure that the openings are correct, and (4) the tool has been adjusted correctly.

**Die Assembly 9-1478242-0**

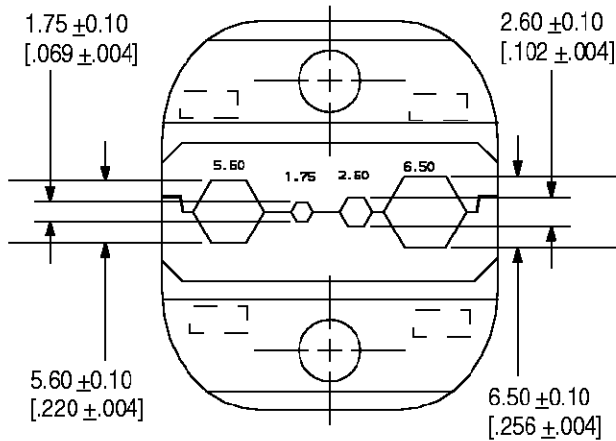

*Figure 5*

Figure 5 provides information on die opening sizes.

**5.3. Ratchet Adjustment**

The tool frame assembly ratchet mechanism features an adjustment wheel with nine settings. The adjustment wheel controls the amount of handle pressure exerted on the tool jaws and crimping dies during crimping. If the crimp is not acceptable, adjust the ratchet as follows:

1. Remove the screw at the ratchet adjustment wheel so that the wheel can be rotated.
2. If the crimp is too loose, turn the wheel to a higher notch. If the crimp is too tight, move the wheel to a lower notch.

3. Replace and tighten the screw at the ratchet adjustment wheel.

If the crimp cannot be made to conform to the dimensions provided in the appropriate product application specification, the tool and/or dies are defective and must be replaced.

**NOTE**

*Other dies of the GREENPAR hand tool series may be used in this tool; however, the ratchet adjustment wheel may require adjustment to achieve acceptable crimp height.*

**6. DAMAGED CONTACTS AND FERRULES**

**CAUTION**

*Damaged contacts or ferrules may not be used. If a center contact or ferrule is damaged during the crimping operation, it must be replaced with a new one.*

**7. PARTS REPLACEMENT**

If the dies are damaged or worn excessively, they must be replaced. Order a new die through your Tyco Electronics Representative, or call 1-800-526-5142, or send a facsimile of your purchase order to 1-717-986-7605, or write to:

CUSTOMER SERVICE (38-35)  
TYCO ELECTRONICS CORPORATION  
P.O. BOX 3608  
HARRISBURG, PA 17105-3608

**8. REVISION SUMMARY**

Per EC 0990-1630-02:

- Update document to corporate requirements
- Change hand tool frame part number 1583203-1 to 9-1478240-0 in Figure 1 and Section 1, INTRODUCTION