

A2 CABLE GLAND

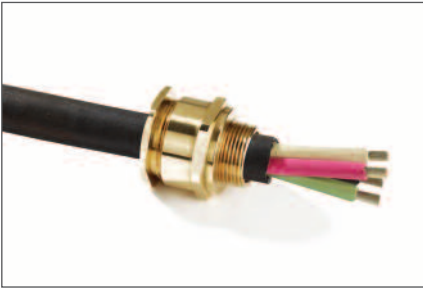

A2 Industrial Cable Gland

CMP A2 type brass indoor and outdoor cable gland for use with all types of Unarmoured cable, providing mechanical cable retention and an environmental seal on the cable outer sheath.

The CMP A2 range of industrial cable glands is designed and tested to BS 6121:Part 1:1989, meets or surpasses the requirements of EN 50262 :1999, and is produced from Brass grade CuZn39Pb3 (CW614N) to EN12168. Other materials including Aluminium are also available in this standard design.

TECHNICAL DATA	
Type	A2
Design Specification	BS 6121:Part 1:1989, EN 50262:1999
EN 50262 Mechanical Classifications	Retention = Class B, Impact = Level 8,
GOST R Certificate Number	POCC GB. ГБ05.H00110
GOST K Certificate Number	KZ7500052.05.01.00063
RoK Permit for Use Number	08-067693
Lloyds Approval Number	01/00171
ABS Approval Number	01-LD 234401-PDA
Continuous Operating Temperature	-60°C to +150°C
Ingress Protection Rating	IP66, IP67, IP68
Ingress Protection Document	5046 C549D
Deluge Protection Compliance	DTS01 : 91
Deluge Protection Document	5046 C549-D
Standard Gland Material	Brass
Alternative Gland Material	Electroless Nickel Plated Brass, Stainless Steel, Aluminium
Seal Material	CMP Formulated Thermoplastic Elastomer
Cable Type	Unarmoured
Sealing Technique	CMP Displacement Seal
Sealing Area(s)	Cable Outer Sheath
Optional Accessories	Adaptor/Reducer, Earth Tag, Entry Thread Seal, Locknut, Serrated Washer, Shroud

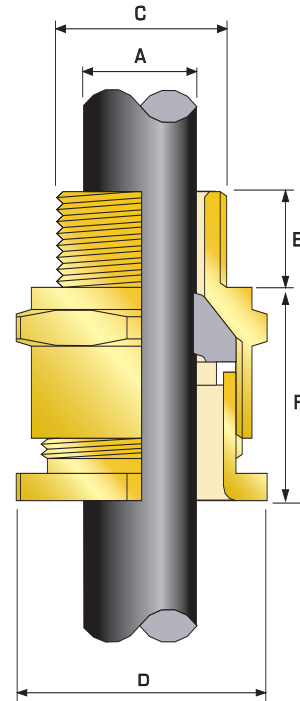

Cable Gland Selection Table

Cable Gland Size	Available Entry Threads 'C'			Minimum Thread Length 'E'	Cable Bedding Diameter 'A'		Across Flats 'D'	Across Corners 'D'	Nominal Protrusion Length 'F'	Ordering Reference (Brass Metric) #	PVC Shroud Reference*	Cable Gland Weight (Kgs)
	Standard	Option			Min	Min	Max	Max				
		Metric	NPT									
20S/16	M20	1/2"	3/4"	10.0	3.1	8.7	24.0	26.6	21.0	20S16A21RA	PVC04	0.054
20S	M20	1/2"	3/4"	10.0	6.1	11.7	24.0	26.6	21.0	20SA21RA	PVC04	0.054
20	M20	1/2"	3/4"	10.0	6.5	14.0	27.0	30.0	24.0	20A21RA	PVC05	0.059
25	M25	3/4"	1"	10.0	11.1	20.0	36.0	39.9	26.0	25A21RA	PVC09	0.112
32	M32	1"	1 1/4"	10.0	17.0	26.3	41.0	45.5	27.0	32A21RA	PVC10	0.128
40	M40	1 1/4"	1 1/2"	15.0	23.5	32.2	50.0	55.4	28.0	40A21RA	PVC13	0.168
50S	M50	1 1/2"	2"	15.0	31.0	38.2	55.0	61.0	29.0	50SA21RA	PVC14	0.224
50	M50	2"	2 1/2"	15.0	35.6	44.1	60.0	66.5	30.0	50A21RA	PVC17	0.231
63S	M63	2"	2 1/2"	15.0	41.5	50.0	70.0	77.6	30.0	63SA21RA	PVC20	0.360
63	M63	2 1/2"	3"	15.0	47.2	56.0	75.0	83.2	30.0	63A21RA	PVC22	0.344
75S	M75	2 1/2"	3"	15.0	54.0	62.0	80.0	88.7	32.0	75SA21RA	PVC24	0.466
75	M75	3"	3 1/2"	15.0	61.1	68.0	85.0	94.2	32.0	75A21RA	PVC26	0.395
90	M90	3"	3 1/2"	15.0	66.6	79.4	108.0	120.7	44.0	90A21RA	PVC31	1.346
100	M100	4"	-	15.0	76.0	91.0	123.0	137.8	48.0	100A21RA	150/50HST	1.575
115	M115	-	-	15.0	86.0	98.0	133.4	147.6	55.0	115A21RA	180/60HST	2.322
130	M130	-	-	15.0	97.0	115.0	152.4	164.9	62.0	130A21RA	180/60HST	3.400

All dimensions in millimetres

Note: *LSF Shrouds also available on request. Marine approvals including Lloyds, DNV & ABS are also available from CMP Products. # Other thread forms are available.