

**RoHS
Compliant**

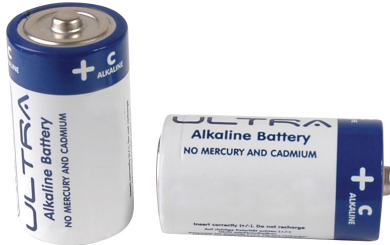

Specifications

Battery Size Code	: D
Battery Technology	: Alkaline
Standard	: IEC 60086-1 and IEC 60086-2
Nominal Voltage	: 1.5 Volts
Open Circuit Voltage	: 1.5 Volts +0.15/-0
Nominal Capacity	: 7200mAh
(Test condition: 3.9Ω Load, continuous discharge, and end voltage 0.9V)	
Weight	: 135±4g
Shelf Life	: 60 Months

Battery service life should meet the values as stated in below table

Discharges					
Test condition			Average duration ¹⁾ at 20°C		
Load	Daily Period	End Voltage	Initial	After 12 months storage ²⁾	After 12 months storage ²⁾
10Ω	4 h/d	0.9V	100 h	93h	85h
3.9Ω	continuous	0.9V	32.5h	30h	27.5h
2.2Ω	continuous	0.9V	17h	15.6h	14.5h
3.9Ω	1 h/d	0.9V	35.5h	32.6h	30.2h

¹⁾ Average service life will be calculated without the highest and the lowest of 9 samples

²⁾ Storage conditions: temperature 20 ±2°C and the Relative Humidity shall be 65 ±20%

Heavy metal content : Mercury(Hg) content should be less than 1 PPM
 Cadmium (Cd) content should be less than 5 PPM
 Lead (Pb) content should be less than 15 PPM

Diagram

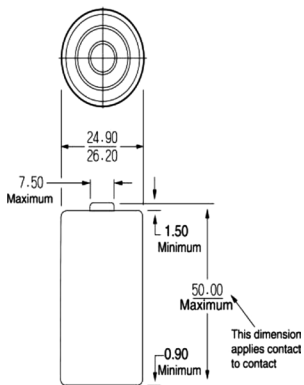

Part Number Table

Description	Part Number
Alkaline Battery, 1.5V, D, 8Ah, Raised Positive and Flat Negative, 34.2mm	BT05892
Alkaline Battery, 1.5 V, D, 12mAh, Raised Positive and Flat Negative, 34.2mm	BT05895

Dimensions : Millimetres

Important Notice : This data sheet and its contents (the "Information") belong to the members of the AVNET group of companies (the "Group") or are licensed to it. No licence is granted for the use of it other than for information purposes in connection with the products to which it relates. No licence of any intellectual property rights is granted. The Information is subject to change without notice and replaces all data sheets previously supplied. The Information supplied is believed to be accurate but the Group assumes no responsibility for its accuracy or completeness, any error in or omission from it or for any use made of it. Users of this data sheet should check for themselves the Information and the suitability of the products for their purpose and not make any assumptions based on information included or omitted. Liability for loss or damage resulting from any reliance on the Information or use of it (including liability resulting from negligence or where the Group was aware of the possibility of such loss or damage arising) is excluded. This will not operate to limit or restrict the Group's liability for death or personal injury resulting from its negligence. Multicomp Pro is the registered trademark of Premier Farnell Limited 2019.