

Smart LED driver with high power factor using BLE Mesh network for indoor lighting

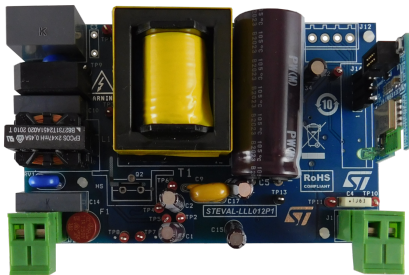

Features

- 35 W LED driver with high power factor (HPF) flyback and constant current (CC) secondary regulation
- Wireless connectivity using BLE module
- ST BLE Mesh mobile app support
- Accepts remote on/off and PWM dimming commands (10 -100%)
- 0.7 A LED current
- 24 - 48 V LED voltage
- THD < 15%
- PF > 0.95 at full load for wide range input
- Efficiency >90%
- Standby consumption < 0.5 W

Description

The STEVAL-LLL012V1 smart LED driver reference design is composed of a power board and a connectivity board.

The power board is a single stage LED driver with high power factor (HPF) and low total harmonic distortion (THD) tailored to LED power supply specifications for smart home lighting applications.

On the primary side, the HVLED001B controller manages the AC-DC HPF flyback converter. Primary side regulation and optocoupler control are applied independently on the chip, both exploiting precise regulation and very low standby power under no load conditions. The converter supplies a power output of 35 W maximum and a LED voltage in the range of 24 - 48 V with a constant current regulation of 0.7 A.

The power board can provide 3.3 V supply voltage (J12 pin 1) to the connectivity board (connected via J12) and to a common GND (J12 pin 4).

Thanks to the embedded programmable BlueNRG-M2SP, the connectivity board can manage the enable/disable state (J12 pin 3) and the PWM dimming (J12 pin 2) signals.

Product summary	
Smart LED driver with high power factor using BLE Mesh network for indoor lighting	STEVAL-LLL012V1
Firmware for the STEVAL-LLL012V1 smart LED driver	STSW-LLL012FW
High power factor flyback controller	HVLED001B
STSW-BNRG-Mesh is a software solution for connecting multiple BLE devices in Mesh networks	STSW-BNRG-Mesh
Very low power application processor module for Bluetooth® low energy v5.2	BlueNRG-M2SP
Applications	LED Lighting Smart Home

1 Schematic diagrams

Figure 1. Power board circuit schematic

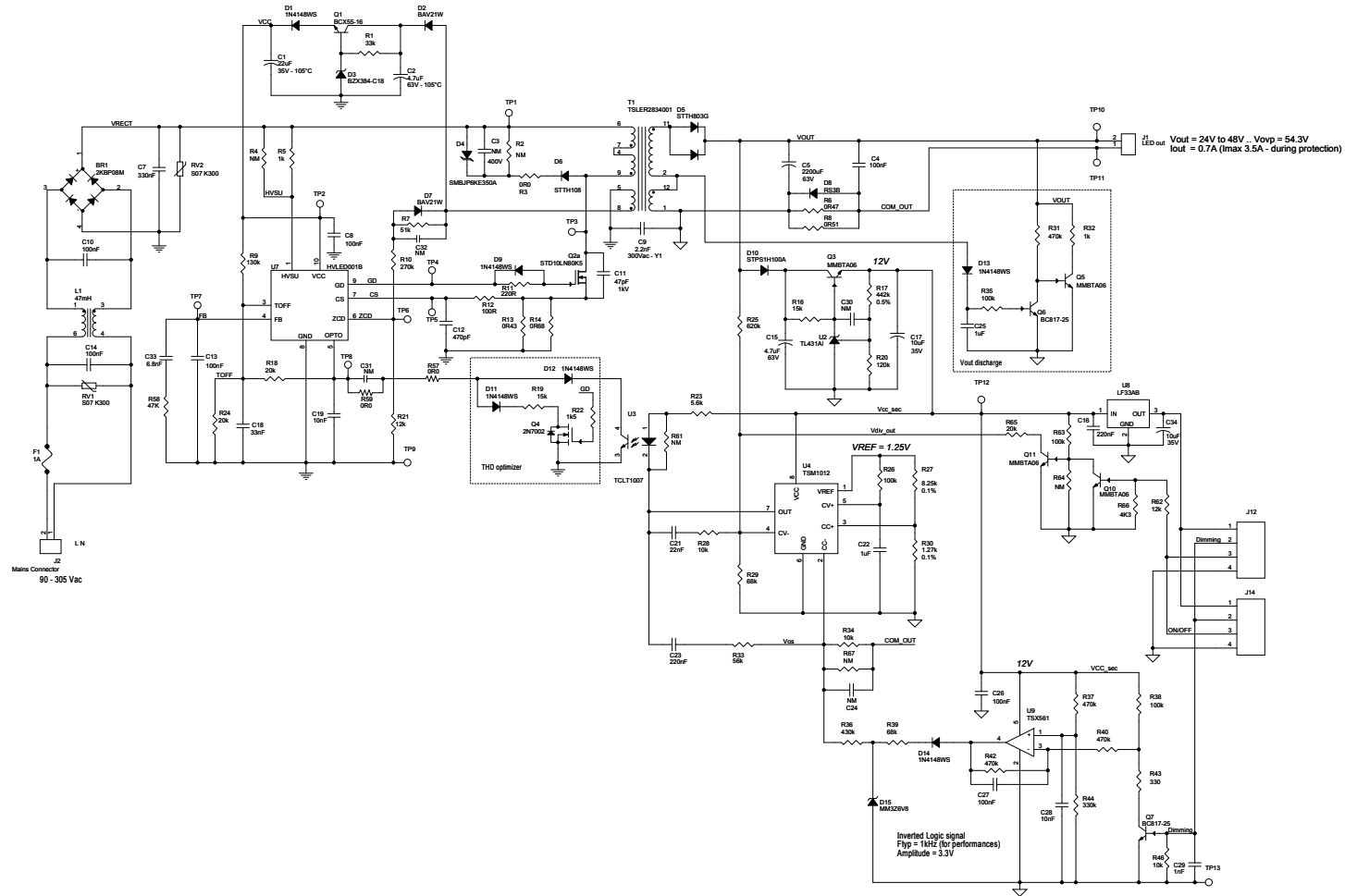
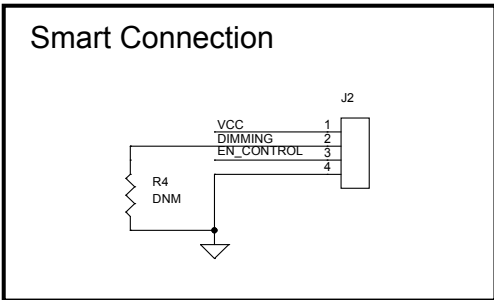
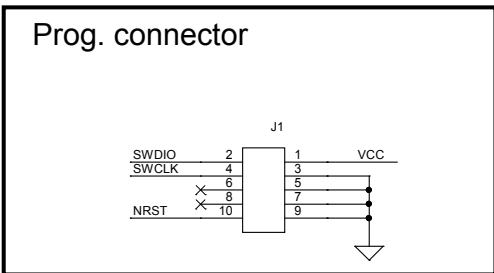
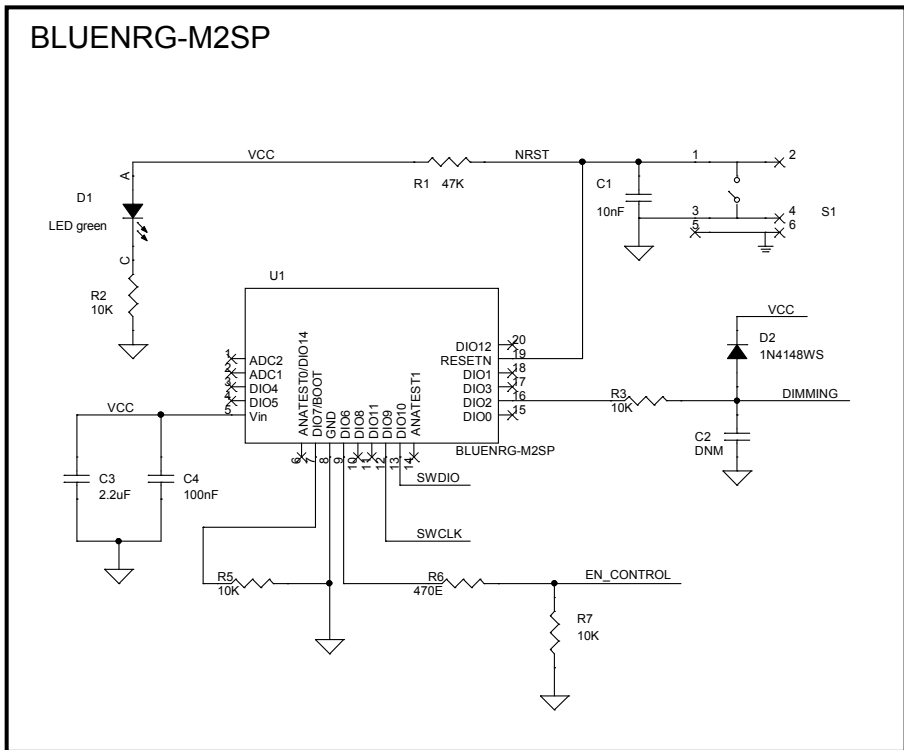

Figure 2. Connectivity board circuit schematic



Revision history

Table 1. Document revision history

Date	Version	Changes
24-Feb-2021	1	Initial release.

IMPORTANT NOTICE – PLEASE READ CAREFULLY

STMicroelectronics NV and its subsidiaries (“ST”) reserve the right to make changes, corrections, enhancements, modifications, and improvements to ST products and/or to this document at any time without notice. Purchasers should obtain the latest relevant information on ST products before placing orders. ST products are sold pursuant to ST’s terms and conditions of sale in place at the time of order acknowledgement.

Purchasers are solely responsible for the choice, selection, and use of ST products and ST assumes no liability for application assistance or the design of Purchasers’ products.

No license, express or implied, to any intellectual property right is granted by ST herein.

Resale of ST products with provisions different from the information set forth herein shall void any warranty granted by ST for such product.

ST and the ST logo are trademarks of ST. For additional information about ST trademarks, please refer to www.st.com/trademarks. All other product or service names are the property of their respective owners.

Information in this document supersedes and replaces information previously supplied in any prior versions of this document.

© 2021 STMicroelectronics – All rights reserved