

Cree® XLamp® XR-E and XR-C LED Binning and Labeling

Introduction

This document describes the product nomenclature required to select and order Cree’s XLamp XR-E and XR-C LEDs. XLamp XR-E and XR-C LEDs are tested and sorted into bins which are then combined into orderable kits identified by an order code.

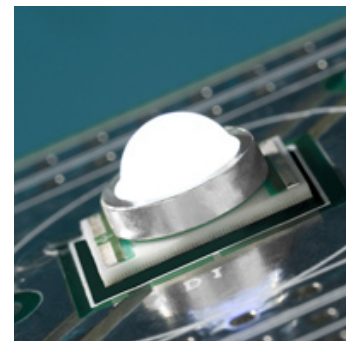

All XLamp LEDs are tested and sorted by color and brightness into a unique bin. Each bin contains LEDs from only one color and brightness group and is uniquely identified by a bin code. White XLamp LEDs are sorted by chromaticity (color) and luminous flux (brightness). Color XLamp LEDs are sorted by dominant wavelength (color) and luminous flux (brightness), or in the case of royal blue, radiant flux (brightness). LEDs are shipped on reels containing LEDs from one bin and are always labeled with the appropriate bin code.

Kits contain LEDs from a number of similar bins and are fully defined by their order codes. A full explanation of the order codes for each family, as well as a list of standard order codes, is provided in this document.

Table of Contents

Bin- and Order-Code Format	2
Performance Groups – Brightness	3
Performance Groups – Chromaticity	4
Performance Groups – Dominant Wavelength	5
Cree’s Standard Chromaticity Regions Plotted on the 1931 CIE Curve	6
Standard Order Codes and Bins (XR-C Cool White).....	7
Standard Order Codes and Bins (XR-C Neutral and Warm White).....	8
Standard Order Codes and Bins (XR-E Cool White).....	9
Standard Order Codes and Bins (XR-E Neutral White)	10
Standard Order Codes and Bins (XR-E Warm White).....	11
Standard Order Codes and Bins (XR-E Blue and Green)	12

Bin- and Order-Code Format

Bin codes and order codes are configured in the following manner:

Order Code

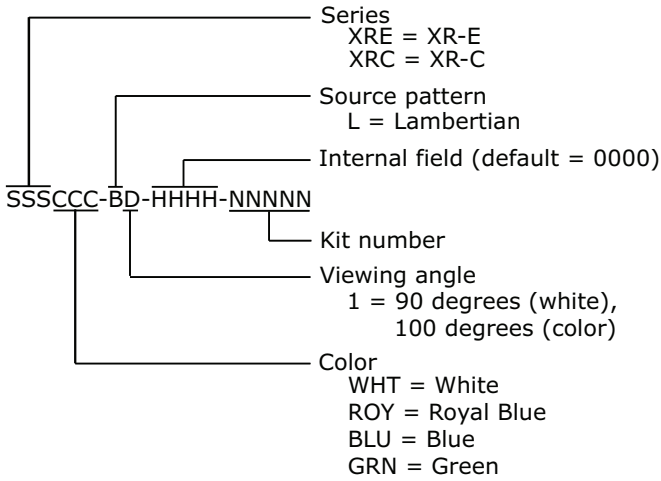

Bin Code

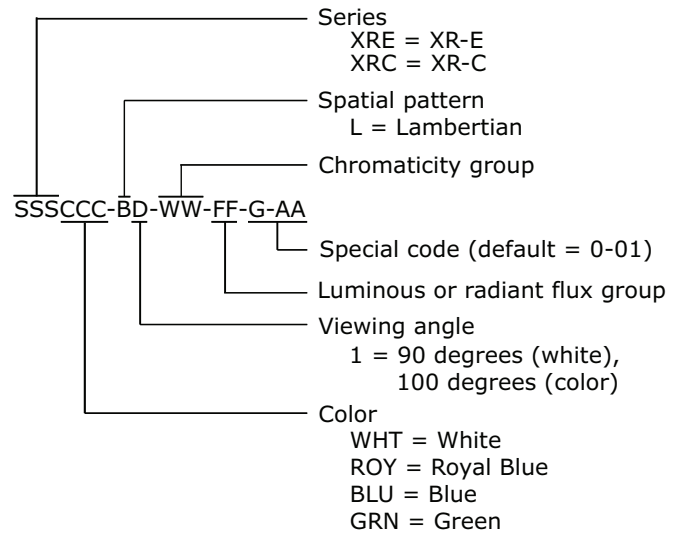

Performance Groups – Brightness

White XLamp LEDs are tested for luminous flux and placed into one of the following luminous-flux groups:

Group Code	Min. Luminous Flux @ 350 mA (lm)	Max. Luminous Flux @ 350 mA (lm)
M2	39.8	45.7
M3	45.7	51.7
N2	51.7	56.8
N3	56.8	62.0
N4	62.0	67.2
P2	67.2	73.9
P3	73.9	80.6
P4	80.6	87.4
Q2	87.4	93.9
Q3	93.9	100
Q4	100	107
Q5	107	114

Color XLamp LEDs are tested for luminous flux and placed into one of the following luminous-flux groups:

Group	Min. Luminous Flux @ 350 mA (lm)	Max. Luminous Flux @ 350 mA (lm)
G	13.9	18.1
H	18.1	23.5
J	23.5	30.6
K	30.6	39.8
M	39.8	51.7
N	51.7	67.2
P	67.2	87.4
Q	87.4	114

Royal-blue XLamp LEDs are tested for radiant flux and placed into one of the following radiant-flux groups:

Group	Min. Radiant Flux (mW) @ 350 mA	Max. Radiant Flux (mW) @ 350 mA
12	250	300
13	300	350
14	350	425
15	425	500
16	500	600

Performance Groups – Chromaticity

White XLamp LEDs are tested for chromaticity and placed into one of the regions defined by the bounding coordinates below.

White Chromaticity Region Bounding Coordinates

Region	x	y	Region	x	y
WK	.283	.284	WF	.314	.355
	.295	.297		.316	.332
	.298	.288		.306	.322
	.287	.276		.301	.342
WA	.292	.306	WP	.317	.319
	.295	.297		.329	.330
	.283	.284		.329	.318
	.279	.291		.318	.308
WM	.295	.297	WD	.329	.345
	.308	.311		.329	.330
	.310	.300		.317	.319
	.298	.288		.316	.332
WB	.306	.322	WG	.329	.369
	.308	.311		.329	.345
	.295	.297		.316	.332
	.292	.306		.314	.355
WE	.301	.342	WJ	.329	.330
	.306	.322		.329	.345
	.292	.306		.346	.359
	.287	.321		.344	.342
WN	.308	.311	WH	.348	.384
	.317	.319		.346	.359
	.318	.308		.329	.345
	.310	.300		.329	.369
WC	.316	.332			
	.317	.319			
	.308	.311			
	.306	.322			

Performance Groups – Chromaticity (continued)

Region	x	y	Region	x	y	Region	x	y	Region	x	y		
3A	.3371	.3490	3B	.3376	.3616	3C	.3463	.3687	3D	.3451	.3554		
	.3451	.3554		.3463	.3687		.3551	.3760		.3533	.3620		
	.3440	.3428		.3451	.3554		.3533	.3620		.3451	.3554	.3440	.3428
	.3366	.3369		.3371	.3490		.3451	.3554		.3440	.3428		
4A	.3512	.3465	4B	.3529	.3597	4C	.3615	.3659	4D	.3590	.3521		
	.3529	.3597		.3548	.3736		.3641	.3804		.3615	.3659		
	.3615	.3659		.3641	.3804		.3736	.3874		.3702	.3722		
	.3590	.3521		.3615	.3659		.3702	.3722		.3670	.3578		
5A	.3670	.3578	5B	.3702	.3722	5C	.3825	.3798	5D	.3783	.3646		
	.3702	.3722		.3736	.3874		.3869	.3958		.3825	.3798		
	.3825	.3798		.3869	.3958		.4006	.4044		.3950	.3875		
	.3783	.3646		.3825	.3798		.3950	.3875		.3898	.3716		
6A	.3889	.3690	6B	.3941	.3848	6C	.4080	.3916	6D	.4017	.3751		
	.3941	.3848		.3996	.4015		.4146	.4089		.4080	.3916		
	.4080	.3916		.4146	.4089		.4299	.4165		.4221	.3984		
	.4017	.3751		.4080	.3916		.4221	.3984		.4147	.3814		
7A	.4147	.3814	7B	.4221	.3984	7C	.4342	.4028	7D	.4259	.3853		
	.4221	.3984		.4299	.4165		.4430	.4212		.4342	.4028		
	.4342	.4028		.4430	.4212		.4562	.4260		.4465	.4071		
	.4259	.3853		.4342	.4028		.4465	.4071		.4373	.3893		
8A	.4373	.3893	8B	.4465	.4071	8C	.4582	.4099	8D	.4483	.3919		
	.4465	.4071		.4562	.4260		.4687	.4289		.4582	.4099		
	.4582	.4099		.4687	.4289		.4813	.4319		.4700	.4126		
	.4483	.3919		.4582	.4099		.4700	.4126		.4593	.3944		

Performance Groups – Dominant Wavelength

Royal blue and blue XLamp LEDs are tested for dominant wavelength (DWL) and placed into one of the DWL groups defined below.

Color	DWL Group	Min. DWL (nm) @ 350 mA	Max. DWL (nm) @ 350 mA
Royal Blue	D3	450	455
	D4	455	460
	D5	460	465
Blue	B3	465	470
	B4	470	475
	B5	475	480
	B6	480	485
Green	G2	520	525
	G3	525	530
	G4	530	535

Cree's Standard Chromaticity Regions Plotted on the 1931 CIE Curve

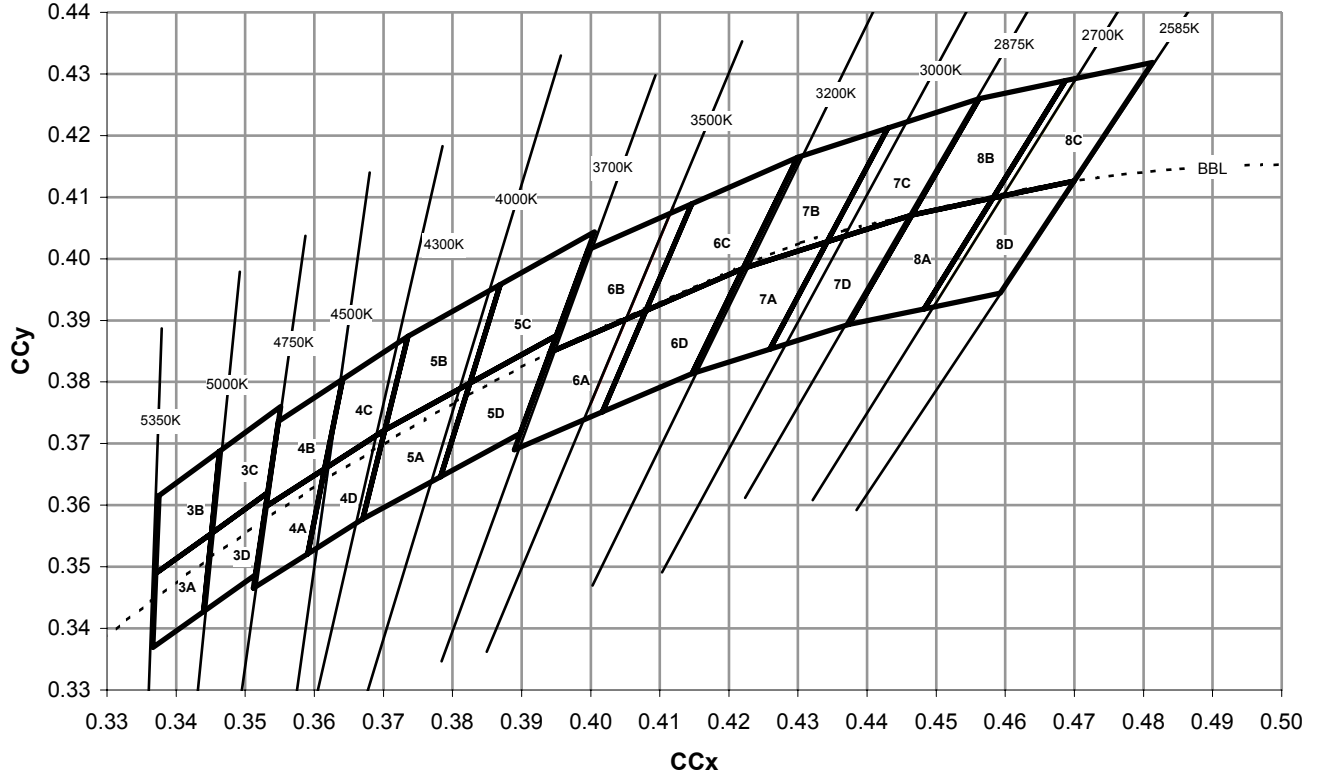
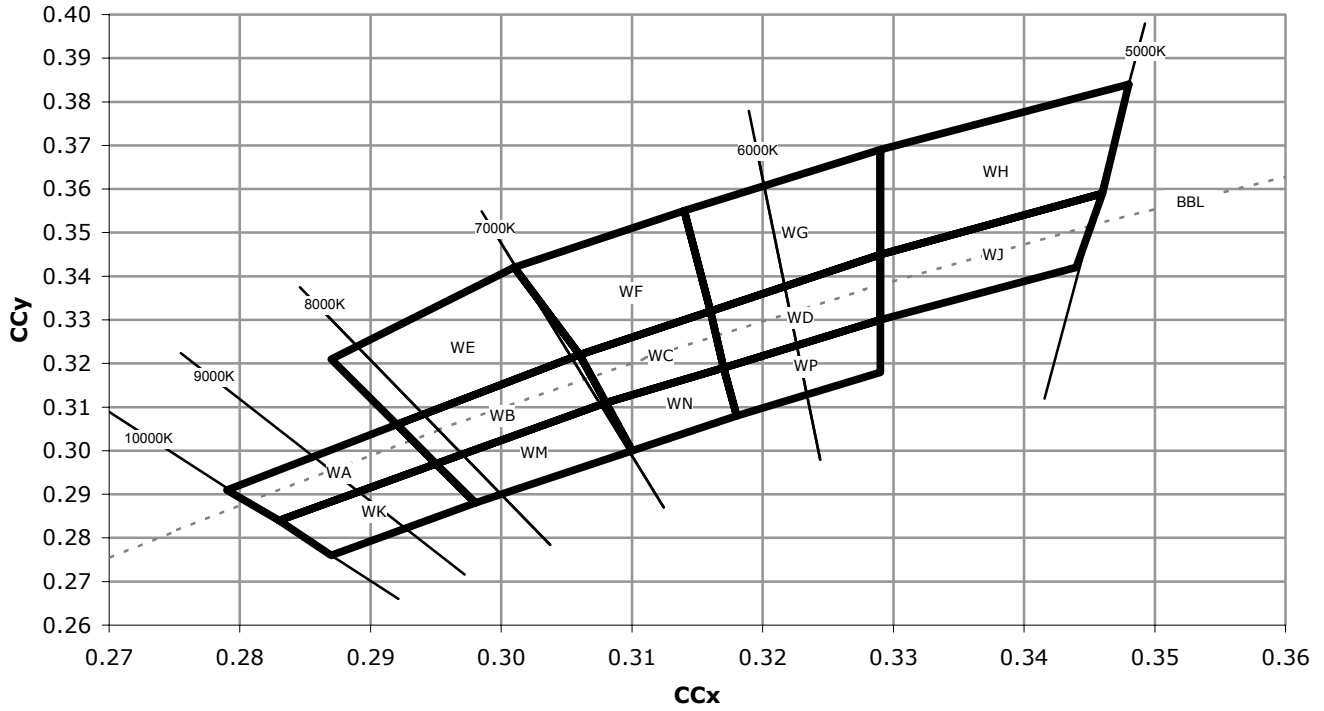

Standard Order Codes and Bins (XR-C Cool White)

The following tables list standard kit numbers and performance bins. Kit numbers completely describe an order code's chromaticity regions and luminous flux range.

XLamp XR-C LED Standard Order Codes - White			
Min. Luminous Flux (lm) @ 350 mA		Chromaticity Regions	Kit Number
Group	Flux (lm)		
Cool White (5000 K - 10,000 K)			
M3	45.7	WA, WB, WC, WD, WE, WF, WG, WH, WJ, WK, WM, WN, WP	00301
		WC, WD, WF, WG	00302
		WC, WD, WF, WG, WH, WJ, WN, WP	00303
N2	51.7	WA, WB, WC, WD, WE, WF, WG, WH, WJ, WK, WM, WN, WP	00401
		WC, WD, WF, WG	00402
		WC, WD, WF, WG, WH, WJ, WN, WP	00403
N3	56.8	WA, WB, WC, WD, WE, WF, WG, WH, WJ, WK, WM, WN, WP	00501
		WC, WD, WF, WG	00502
		WC, WD, WF, WG, WH, WJ, WN, WP	00503
N4	62.0	WA, WB, WC, WD, WE, WF, WG, WH, WJ, WK, WM, WN, WP	00601
		WC, WD, WF, WG	00602
		WC, WD, WF, WG, WH, WJ, WN, WP	00603
P2	67.2	WA, WB, WC, WD, WE, WF, WG, WH, WJ, WK, WM, WN, WP	00701
		WC, WD, WF, WG	00702
		WC, WD, WF, WG, WH, WJ, WN, WP	00703

For other flux and chromaticity combinations, contact Cree or an authorized distributor.

Standard Order Codes and Bins (XR-C Neutral and Warm White)

The following tables list standard kit numbers and performance bins. Kit numbers completely describe an order code's chromaticity regions and luminous flux range.

XLamp XR-C LED Standard Order Codes - White				
Min Luminous Flux (lm) @ 350 mA		Chromaticity Regions	Kit Number	CCT
Group	Flux (lm)			
Neutral White (3700 K – 5000 K)				
M3	45.7	3A, 3B, 3C, 3D	003E3	5000 K
		3C, 3D, 4A, 4B	003F4	4750 K
		4A, 4B, 4C, 4D	003E4	4500 K
		4C, 4D, 5A, 5B	003F5	4300 K
		5A, 5B, 5C, 5D	003E5	4000 K
		5C, 5D, 6A, 6B	003F6	3700 K
N2	51.7	3A, 3B, 3C, 3D	004E3	5000 K
		3C, 3D, 4A, 4B	004F4	4750 K
		4A, 4B, 4C, 4D	004E4	4500 K
		4C, 4D, 5A, 5B	004F5	4300 K
		5A, 5B, 5C, 5D	004E5	4000 K
		5C, 5D, 6A, 6B	004F6	3700 K
N3	56.8	3A, 3B, 3C, 3D	005E3	5000 K
		3C, 3D, 4A, 4B	005F4	4750 K
		4A, 4B, 4C, 4D	005E4	4500 K
		4C, 4D, 5A, 5B	005F5	4300 K
		5A, 5B, 5C, 5D	005E5	4000 K
		5C, 5D, 6A, 6B	005F6	3700 K
Warm White (2600 K – 3700 K)				
M2	39.8	6A, 6B, 6C, 6D	002E6	3500 K
		6C, 6D, 7A, 7B	002F7	3200 K
		7A, 7B, 7C, 7D	002E7	3000 K
		7C, 7D, 8A, 8B	002F8	2900 K
		8A, 8B, 8C, 8D	002E8	2700 K
M3	45.7	6A, 6B, 6C, 6D	003E6	3500 K
		6C, 6D, 7A, 7B	003F7	3200 K
		7A, 7B, 7C, 7D	003E7	3000 K
		7C, 7D, 8A, 8B	003F8	2900 K
		8A, 8B, 8C, 8D	003E8	2700 K
N2	51.7	6A, 6B, 6C, 6D	004E6	3500 K
		6C, 6D, 7A, 7B	004F7	3200 K

For other flux and chromaticity combinations, contact Cree or an authorized distributor.

Standard Order Codes and Bins (XR-E Cool White)

The following tables list standard kit numbers and performance bins. Kit numbers completely describe an order code's chromaticity regions and luminous flux range.

XLamp XR-E LED Standard Order Codes - White			
Min. Luminous Flux (lm) @ 350 mA		Chromaticity Regions	Kit Number
Group	Flux (lm)		
Cool White (5000 K - 10,000 K)			
P2	67.2	WA, WB, WC, WD, WE, WF, WG, WH, WJ, WK, WM, WN, WP	00701
		WC, WD, WF, WG	00702
		WC, WD, WF, WG, WH, WJ, WN, WP	00703
P3	73.9	WA, WB, WC, WD, WE, WF, WG, WH, WJ, WK, WM, WN, WP	00801
		WC, WD, WF, WG	00802
		WC, WD, WF, WG, WH, WJ, WN, WP	00803
P4	80.6	WA, WB, WC, WD, WE, WF, WG, WH, WJ, WK, WM, WN, WP	00901
		WC, WD, WF, WG	00902
		WC, WD, WF, WG, WH, WJ, WN, WP	00903
Q2	87.4	WA, WB, WC, WD, WE, WF, WG, WH, WJ, WK, WM, WN, WP	00A01
		WC, WD, WF, WG	00A02
		WC, WD, WF, WG, WH, WJ, WN, WP	00A03
Q3	93.9	WA, WB, WC, WD, WE, WF, WG, WH, WJ, WK, WM, WN, WP	00B01
		WC, WD, WF, WG	00B02
		WC, WD, WF, WG, WH, WJ, WN, WP	00B03
Q4	100	WA, WB, WC, WD, WE, WF, WG, WH, WJ, WK, WM, WN, WP	00C01
		WC, WD, WF, WG	00C02
		WC, WD, WF, WG, WH, WJ, WN, WP	00C03
Q5	107	WA, WB, WC, WD, WE, WF, WG, WH, WJ, WK, WM, WN, WP	00D01
		WC, WD, WF, WG	00D02
		WC, WD, WF, WG, WH, WJ, WN, WP	00D03

For other flux and chromaticity combinations, contact Cree or an authorized distributor.

Standard Order Codes and Bins (XR-E Neutral White)

The following tables list standard kit numbers and performance bins. Kit numbers completely describe an order code's chromaticity regions and luminous flux range.

XLamp XR-E LED Standard Order Codes - Neutral White (3700 K - 5000 K)				
Minimum Luminous Flux (lm) @ 350 mA		Chromaticity Regions	Kit Number	CCT
Group	Flux (lm)			
N3	56.8	3A, 3B, 3C, 3D	005E3	5000 K
		3C, 3D, 4A, 4B	005F4	4750 K
		4A, 4B, 4C, 4D	005E4	4500 K
		4C, 4D, 5A, 5B	005F5	4300 K
		5A, 5B, 5C, 5D	005E5	4000 K
		5C, 5D, 6A, 6B	005F6	3700 K
N4	62.0	3A, 3B, 3C, 3D	006E3	5000 K
		3C, 3D, 4A, 4B	006F4	4750 K
		4A, 4B, 4C, 4D	006E4	4500 K
		4C, 4D, 5A, 5B	006F5	4300 K
		5A, 5B, 5C, 5D	006E5	4000 K
		5C, 5D, 6A, 6B	006F6	3700 K
P2	67.2	3A, 3B, 3C, 3D	007E3	5000 K
		3C, 3D, 4A, 4B	007F4	4750 K
		4A, 4B, 4C, 4D	007E4	4500 K
		4C, 4D, 5A, 5B	007F5	4300 K
		5A, 5B, 5C, 5D	007E5	4000 K
		5C, 5D, 6A, 6B	007F6	3700 K
P3	73.9	3A, 3B, 3C, 3D	008E3	5000 K
		3C, 3D, 4A, 4B	008F4	4750 K
		4A, 4B, 4C, 4D	008E4	4500 K
		4C, 4D, 5A, 5B	008F5	4300 K
		5A, 5B, 5C, 5D	008E5	4000 K
		5C, 5D, 6A, 6B	008F6	3700 K
P4	80.6	3A, 3B, 3C, 3D	009E3	5000 K
		3C, 3D, 4A, 4B	009F4	4750 K
		4A, 4B, 4C, 4D	009E4	4500 K
		4C, 4D, 5A, 5B	009F5	4300 K
		5A, 5B, 5C, 5D	009E5	4000 K
		5C, 5D, 6A, 6B	009F6	3700 K
Q2	87.4	3A, 3B, 3C, 3D	00AE3	5000 K
		3C, 3D, 4A, 4B	00AF4	4750 K
		4A, 4B, 4C, 4D	00AE4	4500 K

For other flux and chromaticity combinations, contact Cree or an authorized distributor.

Standard Order Codes and Bins (XR-E Warm White)

The following tables list standard kit numbers and performance bins. Kit numbers completely describe an order code's chromaticity regions and luminous flux range.

XLamp XR-E LED Standard Order Codes - Warm White (2600 K - 3700 K)				
Minimum Luminous Flux (lm) @ 350 mA		Chromaticity Regions	Kit Number	CCT
Group	Flux (lm)			
N2	51.7	6A, 6B, 6C, 6D	004E6	3500 K
		6C, 6D, 7A, 7B	004F7	3200 K
		7A, 7B, 7C, 7D	004E7	3000 K
		7C, 7D, 8A, 8B	004F8	2900 K
		8A, 8B, 8C, 8D	004E8	2700 K
N3	56.8	6A, 6B, 6C, 6D	005E6	3500 K
		6C, 6D, 7A, 7B	005F7	3200 K
		7A, 7B, 7C, 7D	005E7	3000 K
		7C, 7D, 8A, 8B	005F8	2900 K
		8A, 8B, 8C, 8D	005E8	2700 K
N4	62.0	6A, 6B, 6C, 6D	006E6	3500 K
		6C, 6D, 7A, 7B	006F7	3200 K
		7A, 7B, 7C, 7D	006E7	3000 K
		7C, 7D, 8A, 8B	006F8	2900 K
		8A, 8B, 8C, 8D	006E8	2700 K
P2	67.2	6A, 6B, 6C, 6D	007E6	3500 K
		6C, 6D, 7A, 7B	007F7	3200 K
		7A, 7B, 7C, 7D	007E7	3000 K
		7C, 7D, 8A, 8B	007F8	2900 K
		8A, 8B, 8C, 8D	007E8	2700 K
P3	73.9	6A, 6B, 6C, 6D	008E6	3500 K
		6C, 6D, 7A, 7B	008F7	3200 K
		7A, 7B, 7C, 7D	008E7	3000 K

For other flux and chromaticity combinations, contact Cree or an authorized distributor.

Standard Order Codes and Bins (XR-E Blue and Green)

The following tables list standard kit numbers and performance bins. Kit numbers completely describe an order code's dominant-wavelength range and luminous- or radiant-flux range.

XLamp XR-E LED Standard Order Codes							
Color	Min. Radiant Flux (mW) @ 350 mA		Dominant Wavelength (nm)				Kit Number
	Group	Flux (mW)	Min.		Max.		
			Group	DWL (nm)	Group	DWL (nm)	
Royal Blue	12	250	D3	450	D5	465	00701
			D3	450	D4	460	00702
			D4	455	D5	465	00703
	13	300	D3	450	D5	465	00801
			D3	450	D4	460	00802
			D4	455	D5	465	00803
	14	350	D3	450	D5	465	00901
			D3	450	D4	460	00902
			D4	455	D5	465	00903

XLamp XR-E LED Standard Order Codes - Blue and Green							
Color	Min. Luminous Flux (lm) @ 350 mA		Dominant Wavelength (nm)				Kit Number
	Group	Flux (lm)	Min.		Max.		
			Group	DWL (nm)	Group	DWL (nm)	
Blue	J	23.5	B3	465	B6	485	00J01
			B3	465	B5	480	00J02
			B4	470	B5	480	00J03
	K	30.6	B3	465	B6	485	00K01
			B3	465	B5	480	00K02
			B4	470	B5	480	00K03
Green	P	67.2	G2	520	G4	535	00P01
			G2	520	G3	530	00P02
			G3	525	G4	535	00P03

For other flux and dominant wavelength combinations, contact Cree or an authorized distributor.