



# EV4078-S-00A

## 90V<sub>AC</sub>/60Hz to 265V<sub>AC</sub>/50Hz, 50V/600mA, 30W Single-Stage Flyback Converter with PFC Evaluation Board

### DESCRIPTION

The EV4078-S-00A evaluation board is designed for smart LED lighting and front-end pre-regulator applications with the MP4078.

The MP4078 is a single-stage offline controller with active power factor correction (PFC) for constant output voltage applications. The MP4078 implements primary-side regulation (PSR) control without any secondary feedback circuit or optocoupler for flyback applications.

The EV4078-S-00A features a universal input voltage (90V<sub>AC</sub> to 265V<sub>AC</sub>) with a 50V, 600mA constant voltage output and 30W rated power.

The EV4078-S-00A has ultra-low no-load power consumption and good efficiency under full-load conditions. The EV4078-S-00A can meet IEC61000-3-2 Class C standards, and conducted emission (CE) EN55022 standards. The device features integrated protections, such as brownout functionality, over-current protection (OCP), output over-voltage protection (OVP), output short circuit protection, and over-temperature protection (OTP).

### ELECTRICAL SPECIFICATIONS

Parameter	Symbol	Value	Units
Input voltage	V <sub>IN</sub>	90 to 265	V <sub>AC</sub>
Output voltage	V <sub>OUT</sub>	50	V
Output current	I <sub>OUT</sub>	600	mA
Output power	P <sub>OUT</sub>	30	W

### FEATURES

- Universal Input Voltage (90V<sub>AC</sub> to 265V<sub>AC</sub>)
- Ultra-Low No-Load Power Consumption, Typically 40mW with 230V<sub>AC</sub>
- Power Factor > 0.95 and THD < 10% with 230V<sub>AC</sub>, Full Load
- Primary-Side Control
- Maximum Operating Frequency Limitation (65kHz)
- Cycle-by-Cycle Peak Current Limitation
- Brownout Function
- Over-Current Protection (OCP)
- Output Short-Circuit Protection (SCP)
- Output Over-Voltage Protection (OVP)
- Available in a 98mmx38.5mmx25mm (Except Pins) Package

### APPLICATIONS

- Smart LED Lighting
- Front-End Pre-Regulator

All MPS parts are lead-free, halogen-free, and adhere to the RoHS directive. For MPS green status, please visit the MPS website under Quality Assurance. "MPS", the MPS logo, and "Simple, Easy Solutions" are trademarks of Monolithic Power Systems, Inc. or its subsidiaries.



**Warning:** Although this board is designed to satisfy safety requirements, the engineering prototype has not been agency approved. Therefore, all testing should be performed using an isolation transformer to provide the AC input to the prototype board.

### EV4078-S-00A EVALUATION BOARD

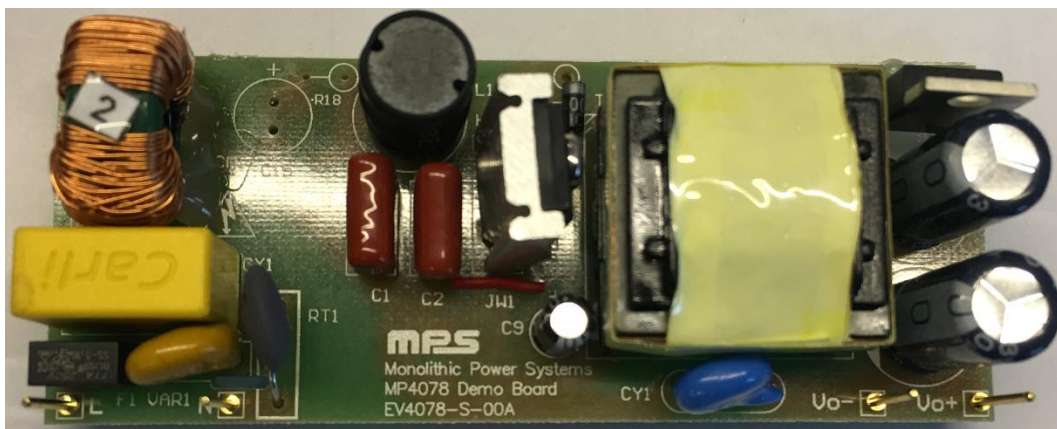

Top View

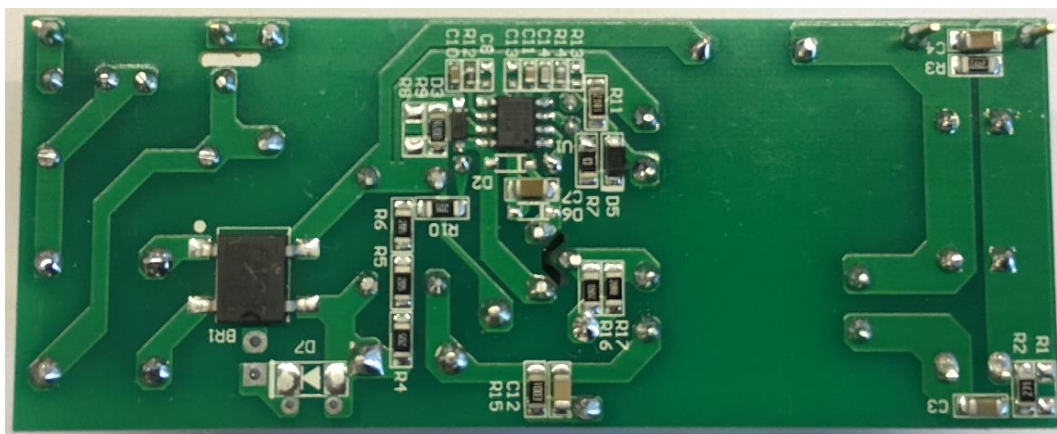

Bottom View

(LxWxH) 98mmx38.5mmx25mm (Except Pins)

Board Number	MPS IC Number
EV4078-S-00A	MP4078GS

## QUICK START GUIDE

1. Preset the power supply ( $V_{IN}$ ) between  $90V_{AC}$  and  $265V_{AC}$ .
2. Turn the power supply off.
3. Connect the power supply terminals to their corresponding ports:
  - a. Line terminal: L port
  - b. Neutral terminal: N port
4. Connect the terminals of the load to the corresponding output ports:
  - a. Positive (+):  $V_{O+}$
  - b. Negative (-):  $V_{O-}$
5. Turn the power supply on after making the connections.

### EVALUATION BOARD SCHEMATIC

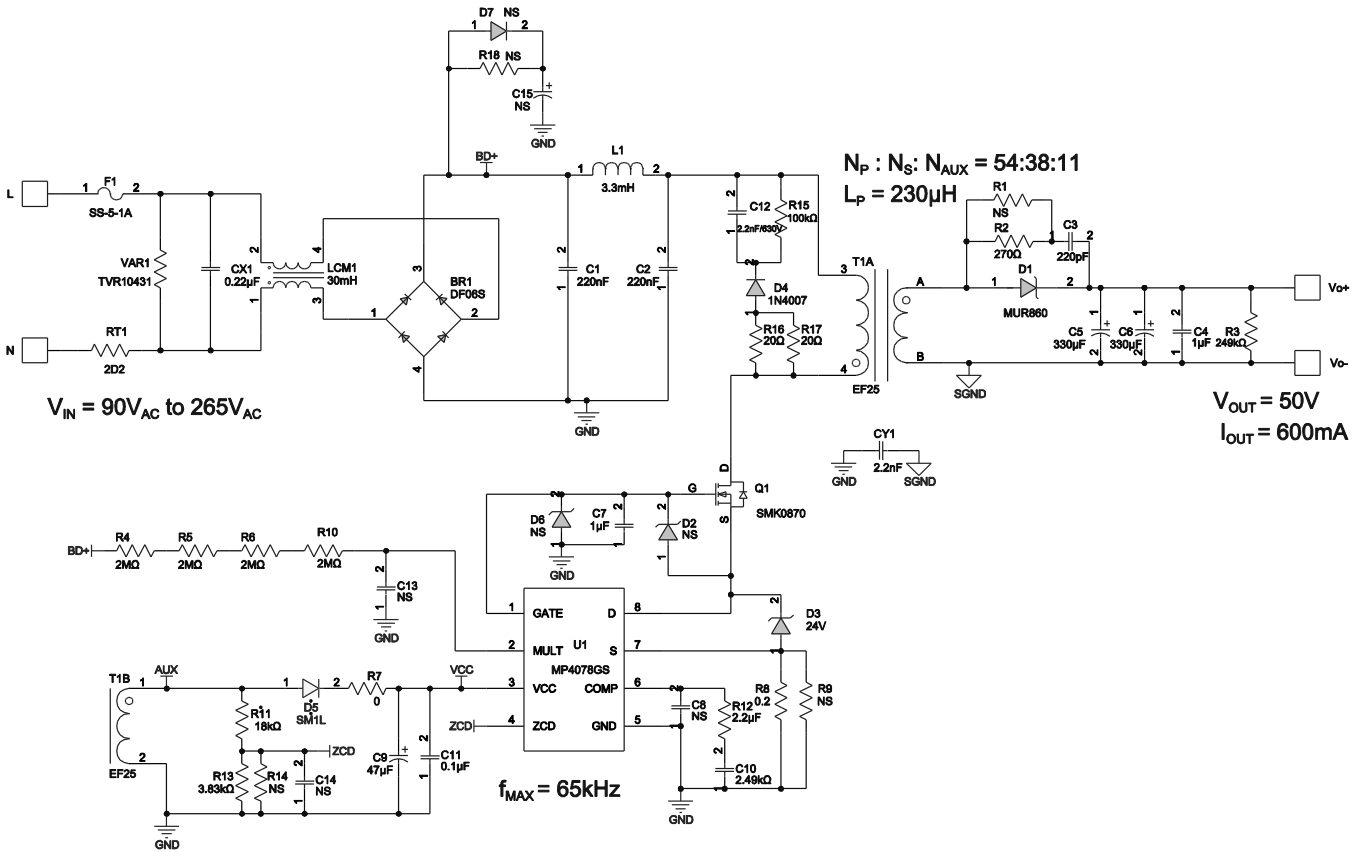

Figure 1: Evaluation Board Schematic

**EV4078-S-00A BILL OF MATERIALS**

Qty	Ref	Value	Description	Package	Manufacturer	Manufacturer P/N
1	BR1	DF06S	Bridge rectifier, 600V, 1A	SMD	Fairchild	DF06S
2	C1, C2	220nF	Capacitor, CBB, 450V	DIP	Carli	TF224K2Y109L270D9R
1	C3	220pF	Ceramic capacitor, 1000V, U2J	1206	Murata	GRM31A7U3A221JW31D
2	C4, C7	1 $\mu$ F	Ceramic capacitor, 100V, X7R	1206	Murata	GRM31CR72A105KA01L
2	C5, C6	330 $\mu$ F	Electrolytic capacitor, 63V	DIP	Jianghai	CD263-63V330
	C8, C13, C15	NS				
1	C9	47 $\mu$ F	Electrolytic capacitor, 25V	DIP	Jianghai	CD286-25V47
1	C10	2.2 $\mu$ F	Ceramic capacitor, 10V, X7R	0603	Murata	GRM188R71A225KE15D
1	C11	0.1 $\mu$ F	Ceramic capacitor, 50V, X7R	0603	Murata	GRM188R71H104KA93D
1	C12	2.2nF	Ceramic capacitor, 630V, U2J	1206	Murata	GRM31BR72J222KW01L
1	C14	22pF	Ceramic capacitor, 50V, X7R	0603	Murata	GRM1885C1H220JA01D
1	CX1	220nF	X-capacitor, 275V, 10%	DIP	Carli	PX224K3ID49L270D9R
1	CY1	2.2nF	Y-capacitor, 4000V, 20%	DIP	Hongke	JN12E222MY02N
1	D1	MUR860	Ultra-fast rectifier, 600V, 8A	TO-220	ON Semiconductors	MUR860
	D2, D6, D7	NS				
1	D3	BZT52C24	Zener diode, 24V	SOD-123	Diodes	BZT52C24
1	D4	1N4007	Rectifier, 1000V, 1A, DIP	DIP	MIC	1N4007
1	D5	SIML	Diode, 1000V, 1A	SOD-123	Taiwan Semiconductor	S1ML
1	F1	SS-5-1A	Fuse, 1A, 250V	DIP	Cooper Bussmann	SS-5-1A
1	HS1		Heatsink for Q1	TO-220		
1	JW1		Jumper wire, 9mm			
1	L1	3.3mH	Inductor, 3.3mH, 0.5A	DIP	EmeiGroup	DR10X16P2M3.3-00
1	LCM1	30mH	CM chock, 30mH, ESR = 0.4 $\Omega$	DIP	EmeiGroup	TP4M30-02
1	Q1	SMK0870	N-channel MOSFET, 700V, 0.9 $\Omega$ /8A	TO-220F	AUK	SMK0870F
	R1, R8, R13, R18	NS				
1	R2	270 $\Omega$	Film resistor, 1%	1206	Yageo	RC1206FR-07270RL
1	R3	249k $\Omega$	Film resistor, 1%	1206	Yageo	RC1206FR-07249KL
4	R4, R5, R6, R10	2M $\Omega$	Film resistor, 5%	1206	Yageo	RC1206JR-072ML

**EV4078-S-00A BILL OF MATERIALS (continued)**

Qty	Ref	Value	Description	Package	Manufacturer	Manufacturer P/N
1	R7	0Ω	Film resistor, 5%	1206	Yageo	RC1206JR-070RL
1	R9	200mΩ	Film resistor, 1%	1206	Yageo	RL1206FR-070R2L
1	R11	18kΩ	Film resistor, 1%	1206	Yageo	RC1206FR-0718KL
1	R12	2.49kΩ	Film resistor, 1%	0603	Yageo	RC0603FR-072K49L
1	R14	3.83kΩ	Film resistor, 1%	0603	Yageo	RC0603FR-073K83L
1	R15	100kΩ	Film resistor, 1%	1206	Yageo	RC1206FR-07100KL
2	R16, R17	20Ω	Film resistor, 1%	1206	Yageo	RC1206FR-0720RL
1	RT1	2Ω	Thermal resistor	DIP	Semitec	2D2-10
1	T1	230μH	Transformer, EF25	DIP	EmeiGroup <sup>(1)</sup>	FX0563
1	U1	MP4078	PSR PFC controller, CV	SOIC-8	MPS	MP4078GS R2
1	VAR1	431KD10	Metal oxide varistor	DIP	Thinking	TVR10431KS42Y
4	V <sub>O+</sub> , V <sub>O-</sub> , L, N		1mm contact pin	DIP		

**Notes:**

- 1) To complete an EmeiGroup transformer sample request, please login at the following website: [www.emeigroup.com](http://www.emeigroup.com).

### EVB TEST RESULTS

Performance waveforms are tested on the evaluation board.  $V_{IN} = 230V_{AC}$ ,  $V_{OUT} = 50V$ ,  $I_{OUT} = 600mA$ ,  $T_A = 25^{\circ}C$ , unless otherwise noted.

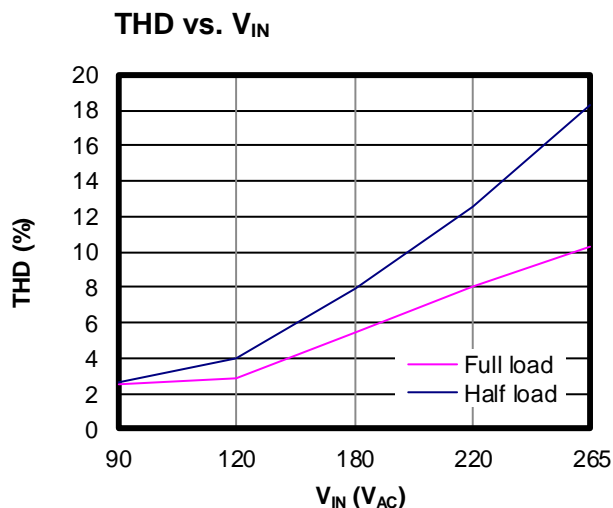
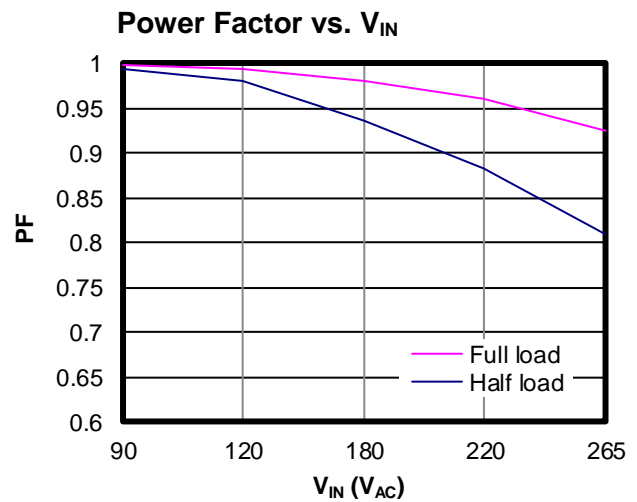
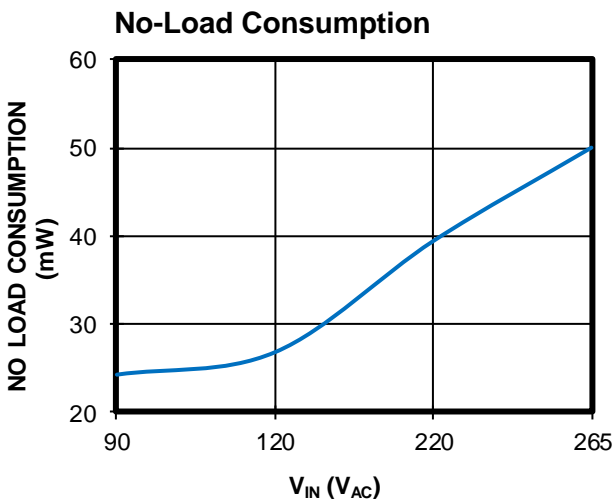
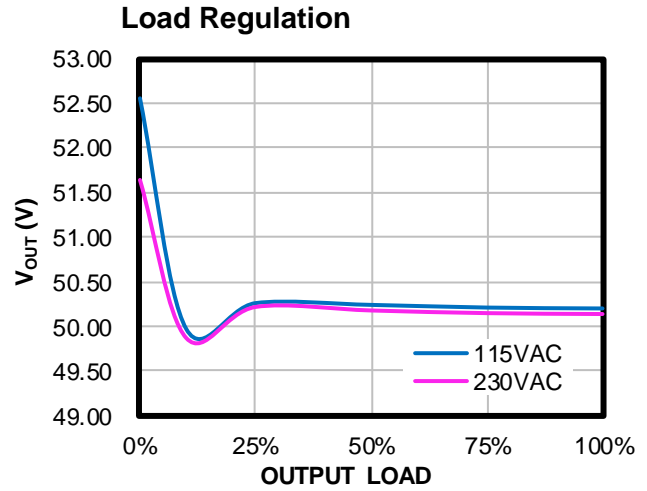
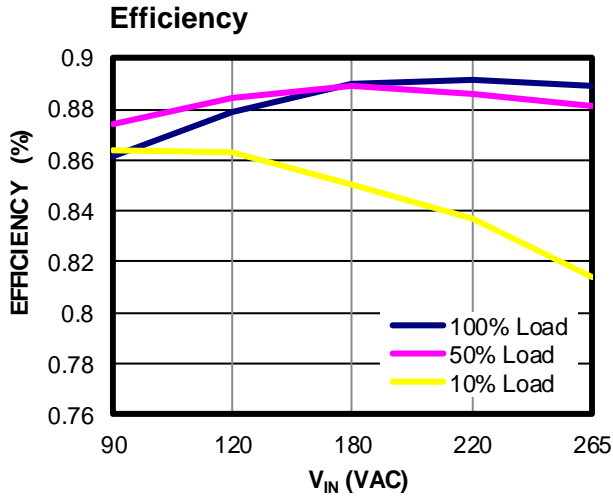

#### Conducted Emissions

Two-wire input, N line

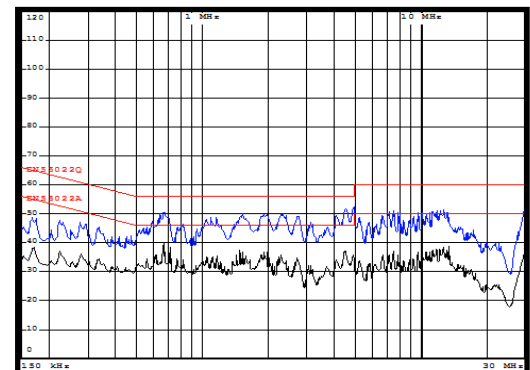

### EVB TEST RESULTS (continued)

Performance waveforms are tested on the evaluation board.  $V_{IN} = 230V_{AC}$ ,  $V_{OUT} = 50V$ ,  $I_{OUT} = 600mA$ ,  $T_A = 25^{\circ}C$ , unless otherwise noted.

#### Conducted Emission

Two-wire input, L line

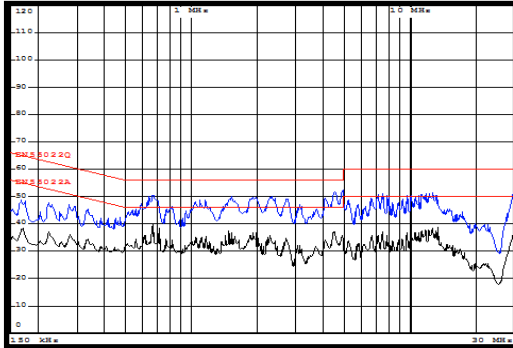



### EVB TEST RESULTS (continued)

Performance waveforms are tested on the evaluation board.  $V_{IN} = 230V_{AC}$ ,  $V_{OUT} = 50V$ ,  $I_{OUT} = 600mA$ ,  $T_A = 25^{\circ}C$ , unless otherwise noted.

#### Input Voltage and Current

115V<sub>AC</sub>, full load

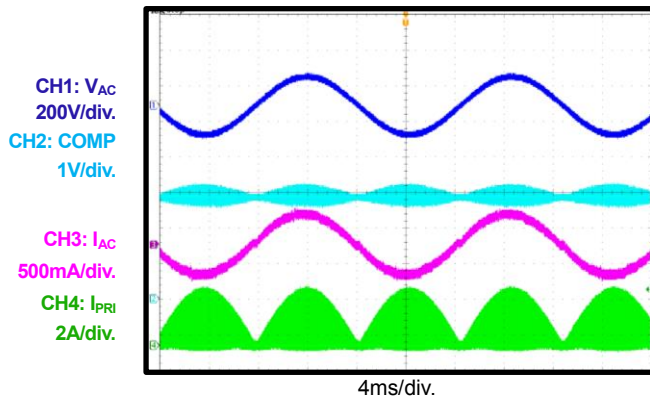

#### Input Voltage and Current

230V<sub>AC</sub>, full load

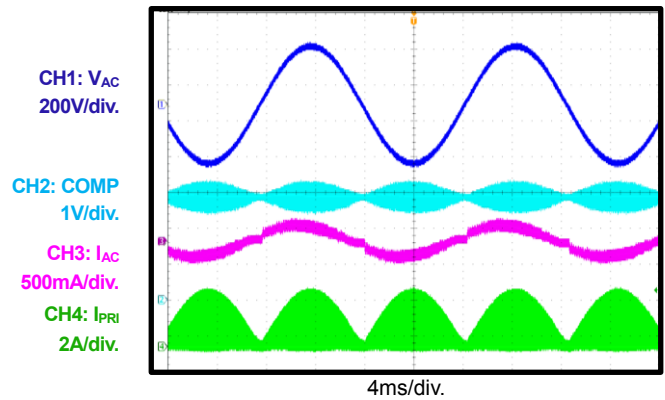

#### Input Voltage and Current

115V<sub>AC</sub>, half-load

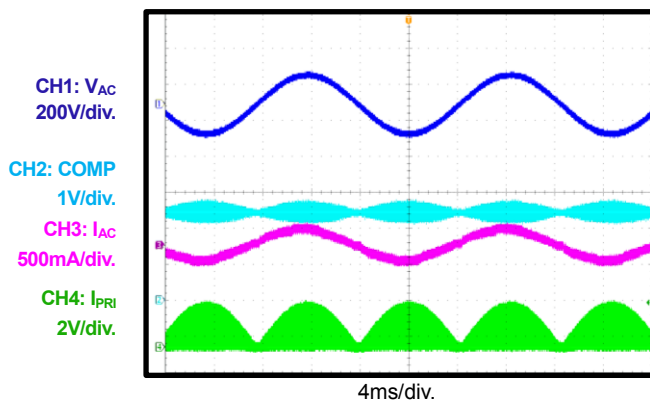

#### Input Voltage and Current

230V<sub>AC</sub>, half-load

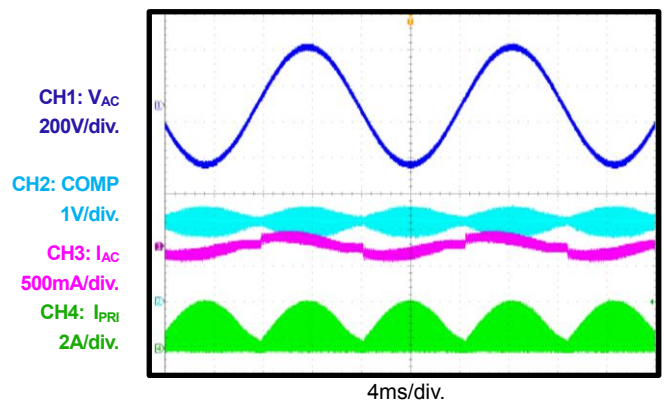

#### Steady State

115V<sub>AC</sub>, full load

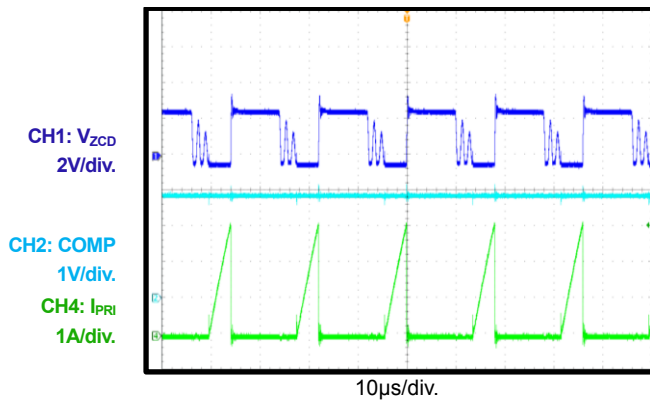

#### Steady State

230V<sub>AC</sub>, full load

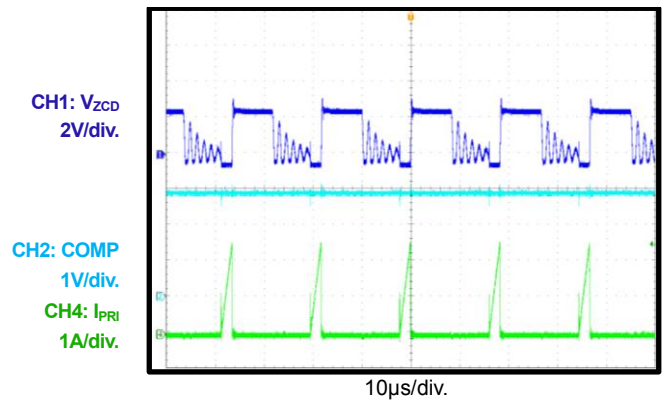

## EVB TEST RESULTS (continued)

Performance waveforms are tested on the evaluation board.  $V_{IN} = 230V_{AC}$ ,  $V_{OUT} = 50V$ ,  $I_{OUT} = 600mA$ ,  $T_A = 25^{\circ}C$ , unless otherwise noted.

**Start-Up**  
115V<sub>AC</sub>, full load

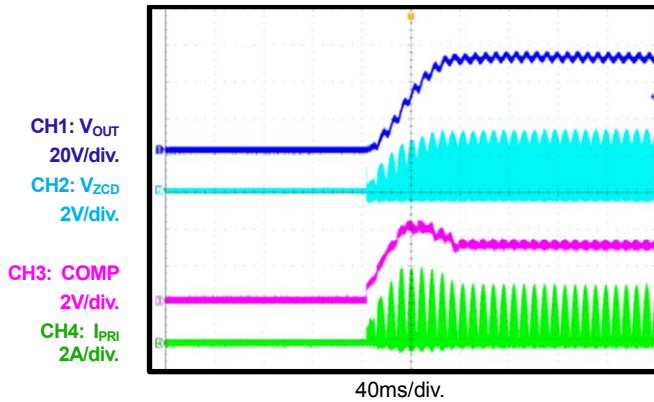

**Start-Up**  
230V<sub>AC</sub>, full load

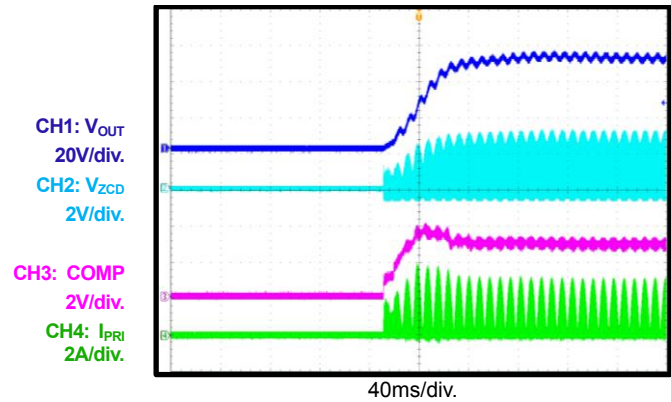

**Start-Up**  
115V<sub>AC</sub>, no load

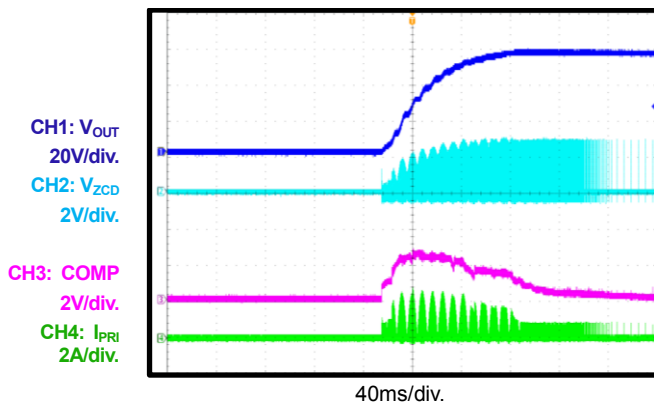

**Start-Up**  
230V<sub>AC</sub>, no load

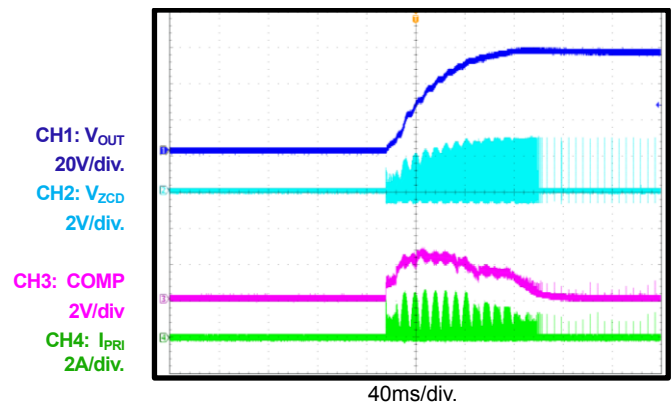

**Shutdown**  
115V<sub>AC</sub>, full load

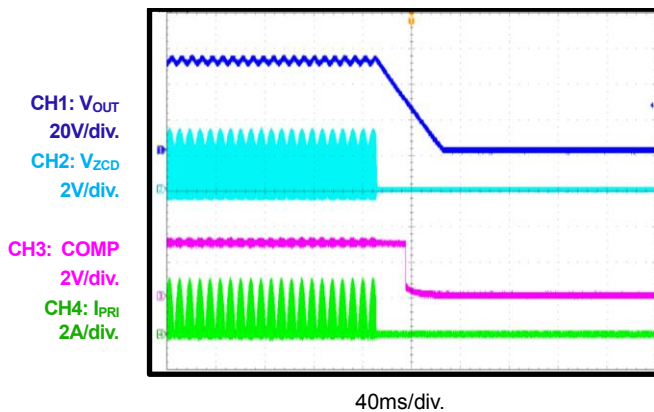

**Shutdown**  
230V<sub>AC</sub>, full load

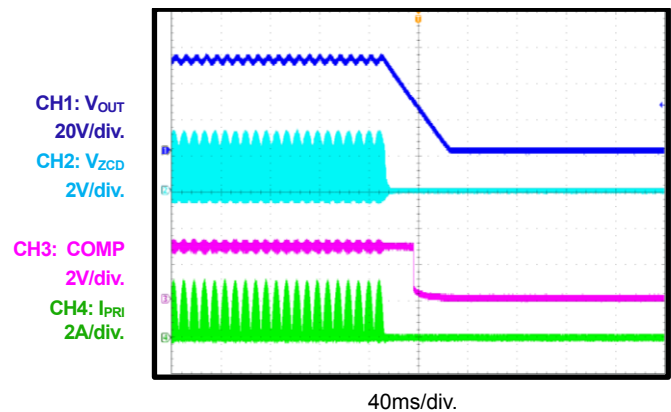

### EVB TEST RESULTS *(continued)*

Performance waveforms are tested on the evaluation board.  $V_{IN} = 230V_{AC}$ ,  $V_{OUT} = 50V$ ,  $I_{OUT} = 600mA$ ,  $T_A = 25^{\circ}C$ , unless otherwise noted.

**SCP**  
230V<sub>AC</sub>, full load

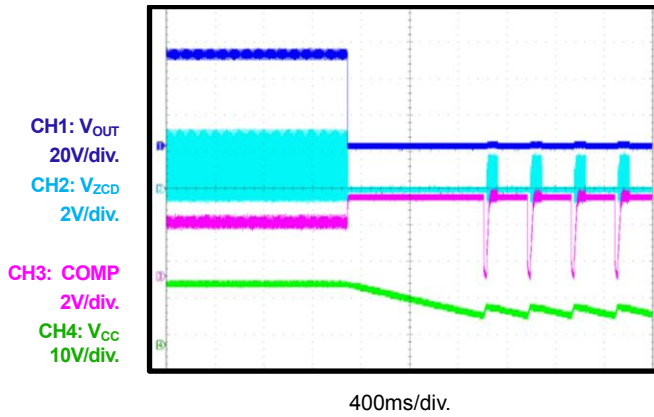

**Short then Start**  
230V<sub>AC</sub>, full load

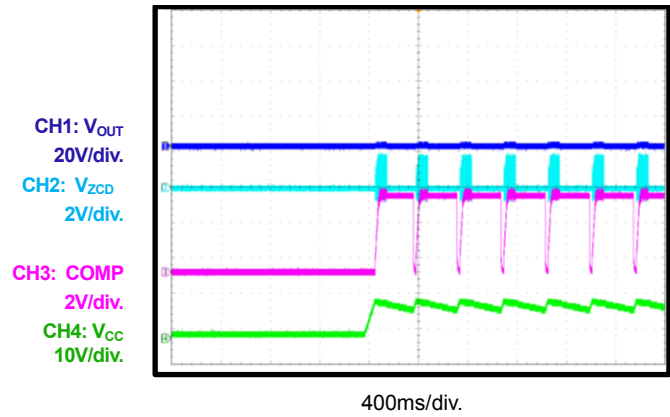

### PCB LAYOUT (SINGLE LAYER)

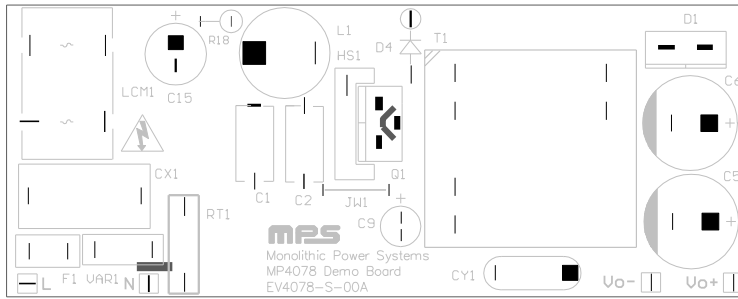

Figure 2: Top Layer

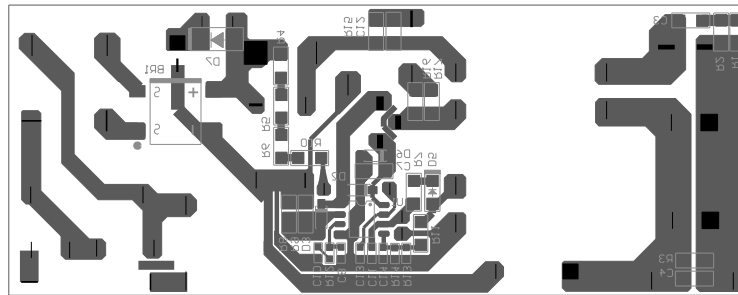
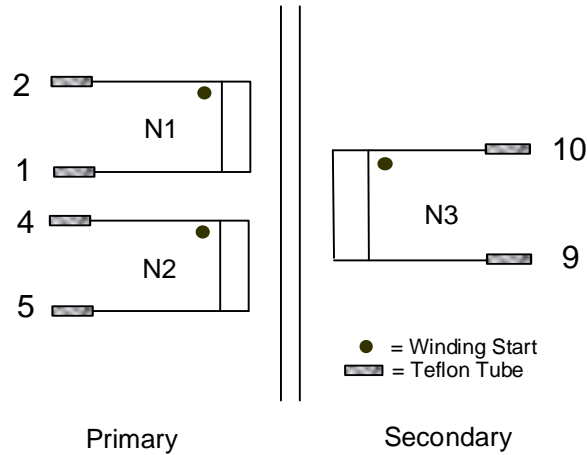

Figure 3: Bottom Layer

## TRANSFORMER SPECIFICATIONS

### Electrical Diagram



**Figure 4: Transformer Electrical Diagram**

1. All winding terminals should be added with a Teflon tube.
2. Wrap one copper foil closed around the core. Wrap a second copper foil closed around the windings. Then solder the copper foil to pin 5 (connected to primary ground) using 0.2mm wire (see Figure 5).

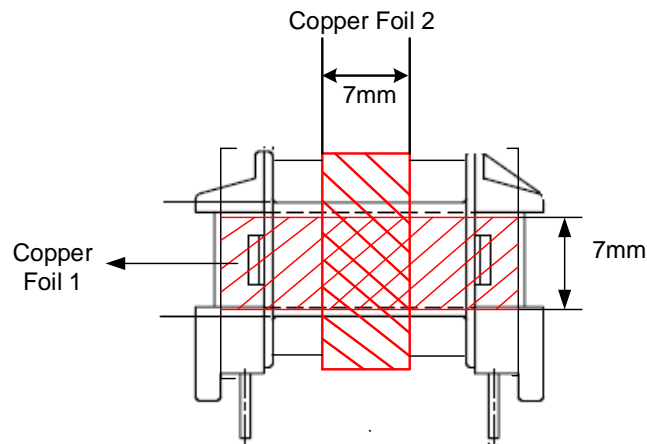

**Figure 5: Copper Foil 1 and Copper Foil 2**

3. Cut pin 3 short for assembly.
4. Remove pin 6, pin 7, and pin 8.
5. Varnish the transformer.

### Winding Diagram

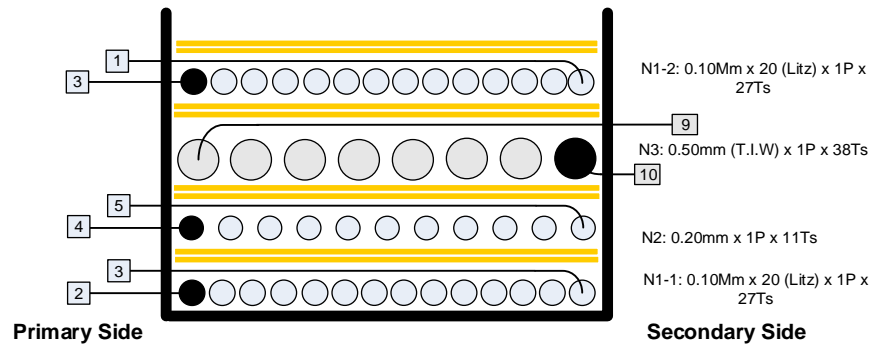

**Figure 5: Winding Diagram**

### Winding Order

Winding No.	Tape Layer No.	Start and End	Magnet Wire $\phi$ (mm)	Turns
N1-1	1	2 to 3	0.10mmx20 Litz	27
N2	1	4 to 5	0.20mmx1	11
N3	1	10 to 9	0.50mmx1 T.I.W	38
N1-2	1	3 to 1	0.10mmx20 Litz	27

### Electrical Specifications

No.	Item	Measuring Terminals	Value	Test Conditions
1	Primary inductance	$L_M$ (1-2)	230 $\mu$ H $\pm$ 5%	60kHz
2	Leakage inductance	$L_{M\_LKG}$ (1-2), short N3 (9-10)	10 $\mu$ H (max)	60kHz
3	Turn ratio	N1:N2:N3	54:11:38	
4	Electrical strength	Primary side to secondary side	AC: 3500V	1s, 1mA
		Primary side to core	AC: 500V	
		Secondary side to core	AC: 3500V	

### Materials

Item	Description
1	Core: EF25/7, UI = 2300; AL = 1950nH/N <sup>2</sup> $\pm$ 25%, ungapped
2	Bobbin: EF25 5 + 5 pin, 1 sec, remove pins 6, 7, and 8, PIN_L = 4.0mm $\pm$ 0.2mm, UL94V-0
3	Wire: $\Phi$ = 0.20mm, 2UEW, class F
4	Litz wire: $\Phi$ = 0.10mmx20P, 2UEW, class F
5	T.I.W wire: $\Phi$ = 0.50mm, class B, yellow
6	Copper foil: 0.025mmx7mm
7	Tape: 16.0mmx0.063mmx66m and 7.0mmx0.063mmx66m
8	Tube: AWG20#, clear and AWG30#, clear
9	Varnish: John C Dolph Co, BC-346A
10	Solder: Yik Shing Tat, Sn99.3/Cu0.7

## CIRCUIT DESCRIPTION

The EV4078-S-00A is designed for smart LED lighting and front-end pre-regulator applications with a 50V, 600mA constant voltage output, and 30W rated power.

The fuse (F1) protects the system from component failure due to excessive short events.

The metal oxide varistor (VAR1) is used for surge tests.

To meet EN55022 standards, the X-capacitor (CX1), common chock (CM1), and differential mode filter (C1, L1, and C2) are implemented to filter EMI noise.

The diode bridge rectifier (BR1) rectifies the input AC voltage.

An RCD snubber (R16, R17, D4, R15, and C12) suppresses the voltage spike on the main MOSFET (Q1) during switching.

Place R4, R5, R6, and R10 in series to form a resistor divider with the internal pull-down resistor of the controller (U1); this resistor divider senses the input voltage. The external resistor string can charge the voltage on the GATE pin during start-up.

C7 stabilizes the voltage on the GATE pin. The Zener diode (D3) between the D pin and the S pin of U1 clamp the voltages on D and S, which limits the main MOSFET's drain-source voltage.

R9 is used as a current-sense resistor that monitors the primary peak current.

D5, R7, and C9 create a biased voltage supply for VCC through the auxiliary winding.

C11 is paralleled with C9 to act as a bypass capacitor for U1's power supply.

R11 and R14 form a resistor divider to sense the plateau voltage of the output voltage feedback's auxiliary winding.

C14 decouples the sensed voltage noise.

R10 and C12 create a compensation network for the internal error amplifier.

D1 is the secondary rectifier diode for the output.

R2 and C3 form an RC snubber to reduce the voltage spike on D1 during switching.

The electrolytic capacitors (C5 and C6) stabilize the output voltage and satisfy the output voltage ripple requirements.

C4 is placed near the output ports to decouple the voltage noise at the output.

R3 is used as a dummy load to regulate the output voltage under no-load and extremely light-load conditions.

The Y-capacitor (CY1) isolates the primary side and the secondary side of the circuit, which improves EMI performance.

## Revision History

Revision #	Revision Date	Description	Pages Updated
1.0	7/5/2019	Initial Release	-
1.1	9/4/2020	Grammar and Formatting Updates	All

**Notice:** The information in this document is subject to change without notice. Please contact MPS for current specifications. Users should warrant and guarantee that third-party Intellectual Property rights are not infringed upon when integrating MPS products into any application. MPS will not assume any legal responsibility for any said applications.